

Aerospace solutions

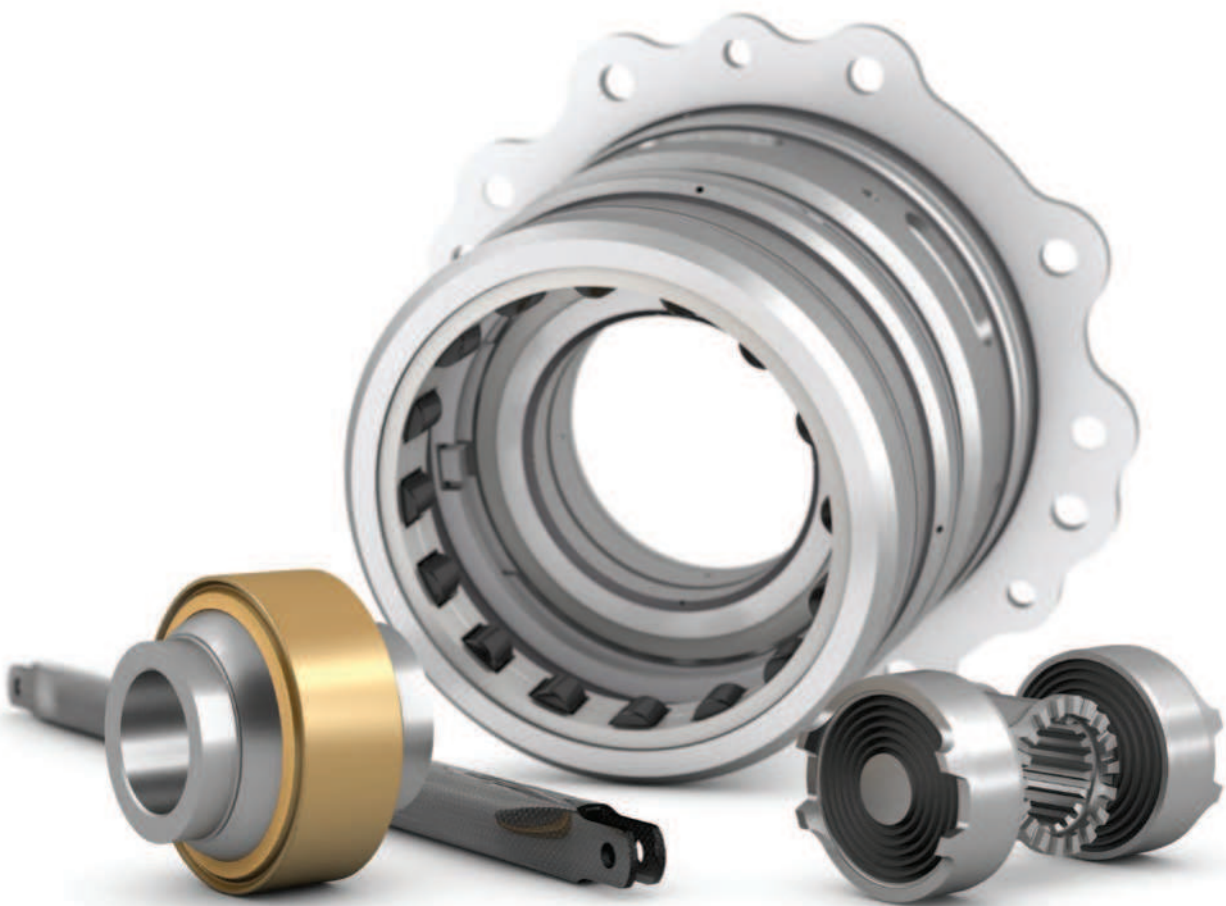

SKF mobile apps and useful links

SKF mobile apps are available from both Apple App Store and Google Play. These apps provide useful information about SKF Group at your fingertips.

You can find information about SKF products beyond aerospace, including industrial rolling bearings with links to the related catalogues.

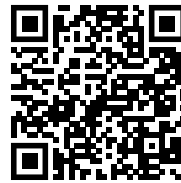

Apple App Store

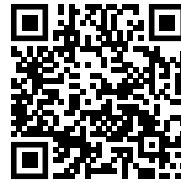

Google Play

To download a PDF document of this catalogue and for more information about the SKF Aerospace solutions, go to skf.com/go/aero. Please note product data in this printed catalogue was accurate on the day of printing. The latest product data is always available for you on skf.com.



Scancode Aero catalogue download

To find support from SKF experts, for queries and to place orders, relevant contacts are available at [our contact page on skf.com](https://skf.com/contact)



Scancode Contacts

skf.com

© SKF, ECOPUR, Endurakote, Endura-Slim, SKF Reali-Slim, Spectraseal and Ultra-Slim are registered trademarks of the SKF Group.

Apple is a trademark of Apple Inc., registered in the US and other countries.

Google Play is a trademark of Google Inc.

Viton is a registered trademark of the Chemours Company

© SKF Group 2022. All rights reserved. Please note that this publication may not be copied or distributed, in whole or in part, unless prior written permission is granted.

Every care has been taken to ensure the accuracy of the information contained in this publication, but no liability can be accepted for any loss or damage whether direct, indirect or consequential arising out of the use of the information contained herein.

PUB 41/P1 18922/3 EN · December 2022

Certain image(s) used under license from Shutterstock.com.

Aerospace

Contents

Unit conversions	6	Rolling bearing selection for airframe applications	35
Units of measurements	6	Performance and operating conditions	35
SKF Group	7	Bearing selection process	36
Company highlights	7	Selecting bearing size and options	36
Sustainability	7	Bearing load carrying capability	37
Rotating equipment performance	8	Static load	37
SKF Care	9	Dynamic load rating	38
Foreword	10	Lubrication	39
SKF Aerospace highlights	10	Operating temperature	40
Advanced development and manufacturing capabilities	10	Sealing and shielding	40
The product portfolio of SKF Group at the service of aerospace industry needs	10	Friction and torque	41
Catalogue contents	11	Bearing interfaces	42
How to use the catalogue	12	Selecting fits	42
Principles of bearing selection	12	Axial location of bearing	42
Product tables	12	Bearing data	45
Indexes	12	Dimensions and tolerances	45
Use case: Select a bearing for an application	13	Material	45
Use case: Find details of a known bearing	13	Surface treatments	46
Use case: Find information about a legacy bearing	13	Sealing and shielding	47
		Internal clearance	47
		Bearing handling	49
		Mounting	49
		Dismounting	50
		Storage	50
		Customized products	51
		Legacy standards	51
		Product tables	
		Metric dimensions	52
		Inch dimensions	78
		Cross-reference	118
		Metric bearings	118
		Inch bearings	124
		2 Spherical plain bearings	126
		Bearing terminology	128
		Bearing types	129
		Metal-to-metal spherical plain bearings	129
		Self-lubricating spherical plain bearings	130
		Rod ends	130
		Common design features	130
		Customized bearings	131
		Basic selection guidelines	131
1 Rolling bearings	30		
Bearing designs and variants	32		
Variants	34		
Bearing materials	34		
Surface treatments	34		
Sealing and shielding solutions	34		
Rod ends	34		
Customized bearings	34		

A Airframe solutions

Bearing types	16
Rolling bearings	16
Spherical plain bearings	18
Rod ends	22
Self-lubricating journal bearings	25
Airframe standard bearings selection process	27
Customized and engineered bearings	27
Basic bearing type selection guide	28

Metal-to-metal spherical plain bearings	132	Dismounting	155
Designs and variants	132	Storage	155
Bearing designs	132	Product tables Metal-to-metal spherical plain bearings	
Bearing variants	132	Metric dimensions	156
Bearing series	132	Inch dimensions	184
Bearing selection process	134	Product tables Self-lubricating spherical plain bearings	
Selecting bearing size and options	134	Metric dimensions	214
Load carrying capability	134	Inch dimensions	230
Internal clearance	136	Cross-reference	268
Lubrication	137	Metal-to-metal spherical plain bearings	268
Operating temperature	138	Metric bearings	268
Bearing data	138	Inch bearings	270
Material	138	Self-lubricating spherical plain bearings	272
Surface treatments	139	Metric bearings	272
Dimensions and tolerances	140	Inch bearings	274
Sealing and shielding	140	3 Rod ends	280
Customized products	141	Designs and variants	282
Self-lubricating spherical plain bearings	142	Optional SKF design features	284
Designs and variants	142	Customized rod ends	284
Bearing selection process	142	Rod end bearing types selection criteria	284
Selecting bearing size and options	142	General specifications	285
Load carrying capability	144	Ball bearing rod ends	285
Friction and torque	146	Design	285
Internal clearance	147	Selecting rod end size and options	285
Operating temperature	147	Lubrication	285
Bearing data	148	Operating temperature	285
Material	148	Friction and torque	285
Surface treatments	149	Rod end data	286
Dimensions and tolerances	149	Metal-to-metal spherical plain bearing rod ends	287
Sealing and shielding	149	Design	287
Lined bore	150	Selecting rod end size and options	287
Customized products	150	Lubrication	288
Legacy products	151	Internal clearance	289
Legacy standards	151	Operating temperature	289
Customer standards	151	Rod end data	289
Bearing interfaces	152	Self-lubricating spherical plain bearing rod ends	291
Fits and tolerances	152	Design	291
Mounting	153	Selecting rod end size and options	291
Bearing retention	154	Friction and torque	291
Anvil staking Process	154	Operating temperature	291
Roller staking	155	Rod end data	291
Threaded or bolted retention plate	155	Rod end bodies	292
		Rod end body load carrying capability	292
		Rod end head shape	293
		Rod end body features	293

Bearing handling	294	5 Engineered pulleys	428
Mounting	294	Designs and variants	430
Dismounting	294	Pulley selection process	430
Storage	294	Load carrying capability	431
Customized products	295	Lubrication	431
Legacy products	295	Operating temperature	431
Legacy standards	295	Internal clearance	431
Product tables		Material	431
Metric dimensions	296	Rolling bearings	431
Inch dimensions	322	Pulley bodies	431
Cross-reference	382	Surface treatments	432
Ball bearing rod ends	382	Rolling bearings	432
Self-lubricating spherical plain bearing rod ends	386	Pulley bodies	432
		Sealing solutions	432
4 Self-lubricating journal bearings	390	Legacy products	432
Designs and variants	392	6 Engineered needle bearings	434
Shell materials	392	Designs and variants	436
Surface treatments	392	Basic selection process	436
Liners	392	Load carrying capability	436
Customized bearings	392	Lubrication	437
Bearing selection process	394	Lubricants	437
Selecting bearing size and options	394	Operating temperature	437
Load carrying capability	394	Material	437
Static load limits	394	Surface treatments	437
Dynamic load rating	394	Mounting	437
Bearing life	394	7 Engineered composite solutions	438
Friction and torque	394	Design and variants	440
Operating temperature	394	Structural rods	440
Selecting fit	396	Adjustable rods	441
Fits and tolerances	396	Other composite solutions	441
Counterface surfaces	396		
Metric bearings	397		
Inch bearings	398		
Bearing data	401		
Material	401		
Surface treatments	401		
Bearing handling	402		
Lubrication	402		
Mounting	402		
Interference fit	402		
Retaining compound	402		
Dismounting	402		
Storage	402		
Customized products	403		
Legacy products	403		
Legacy standards	403		
Customer standards	403		
Product tables	404		
Metric dimensions	404		
Inch dimensions	412		
Cross-reference	426		
Metric bearings	426		
Inch bearings	426		

B Customized bearings for aeroengine solutions

8 Customized bearings for aeroengine solutions	444
Design and variants	447
Sizes	448
Tolerances	448
Special design features and options	448
Materials	449
Materials of rings and rolling elements	449
Materials of cages	449
Storage	450
Bearing remanufacturing	450

C Other aerospace solutions

9 Aerospace thin section bearings	454
SKF Reali-Slim thin section bearings	456
Sizes	456
Bearing types and common design features overview	457
Options	459
Cage types	459
Sealing and shielding	460
Materials	460
Rings and balls	460
Cages	461
Seals	461
Coatings	461
Bearing remanufacturing	461
Engineered designs	461
Ultra-Slim thin section bearings	461
Other engineered designs	461
10 Aerospace specialty and engineered balls	462
Products	464
Flatted balls	464
Hollow balls	464
Ball plugs	465
Tooling and checking balls	465
Master ball sets	465
Materials	466
Ball grades	467
11 Aerospace sealing solutions	468
Product range	470
Materials	470
Sealing rings	471
Aerospace carbon seals for turbine engines	472
Applications	472

Radial shaft seals	472
Diaphragm seals and boots	473
Cassette seals	473
Wear sleeves	473
SKF Speedi-Sleeve	473
SKF Speedi-Sleeve Gold	473
Custom designed wear sleeves	473
Hydraulic seals	474
Piston seals	474
Rod and buffer seals	474
Wiper seals	474
Guide rings	474
Fluid handling seals	475
SKF Spectraseal	475
Rotary manifold seals	475
Locking T-seals	475
12 Elastomeric and damping solutions	476
Product range	478
Elastomeric bearings	478
Isolators and mounts	479
Dampers	479

D Index

Text index	482
Table index	490

Unit conversions

Quantity	Unit	Conversion			
Length	inch	1 mm	0.03937 in	1 in	25,4 mm
Area	square inch	1 mm ²	0.00155 in ²	1 in ²	645,16 mm ²
	square foot	1 m ²	10.76 ft ²	1 ft ²	0,0929 m ²
Volume	cubic inch	1 cm ³	0.061 in ³	1 in ³	16,387 cm ³
	cubic foot	1 m ³	35 ft ³	1 ft ³	0,02832 m ³
	imperial gallon	1 l	0.22 gallon	1 gallon	4,5461 l
	US gallon	1 l	0.2642 US gallon	1 US gallon	3,7854 l
Speed, velocity	foot per second	1 m/s	3.28 ft/s	1 ft/s	0,3048 m/s
	mile per hour	1 km/h	0.6214 mph	1 mph	1,609 km/h
Mass	ounce	1 g	0.03527 oz	1 oz	28,35 g
	pound	1 kg	2.205 lb	1 lb	0,45359 kg
	short ton	1 tonne	1.1023 short ton	1 short ton	0,90719 tonne
	long ton	1 tonne	0.9842 long ton	1 long ton	1,0161 tonne
Density	pound per cubic inch	1 g/cm ³	0.0361 lb/in ³	1 lb/in ³	27,68 g/cm ³
Force	pound-force	1 N	0.225 lbf	1 lbf	4,4482 N
Pressure, stress	pounds per square inch	1 MPa	145 psi	1 psi	6,8948 × 10 ³ Pa
		1 N/mm ²	145 psi		
		1 bar	14.5 psi	1 psi	0,068948 bar
Moment	pound-force inch	1 Nm	8.85 lbf-in	1 lbf-in	0,113 Nm
Power	foot-pound per second	1 W	0.7376 ft-lb/s	1 ft-lb/s	1,3558 W
	horsepower	1 kW	1.36 hp	1 hp	0,736 kW
Temperature	degree	Celsius	$t_C = 0.555 (t_F - 32)$	Fahrenheit	$t_F = 1,8 t_C + 32$

Units of measurements

Airframe bearings use metric or inch dimensions. When bearings are specified in inch dimensions, you will also find the metric values where relevant. Specified values in the two measurement systems units are typically rounded. Therefore, values obtained using conversion formulae may not exactly match those specified.

If you need more unit conversions, use the conversion table above.

Company highlights

Since the start of SKF in 1907, our aim has been to help create competitive advantages for our customers by continuously developing new technologies and new products. We partner with a wide range of customers around the world, in over 40 industries, to help solve their toughest engineering challenges.

This hands-on experience is combined with SKF knowledge about bearings and units, seals, services and lubrication systems to support our customers over their full life cycle of their products, providing outstanding performance and reliability to meet the challenges of today and the future.

SKF provides products, services and solutions which help customers improve safety and process efficiency, reduce friction and extend asset service life, as well as reduce waste, use of material and achieve other sustainability benefits.

These benefits are also the result of the integration of sustainability in all our activities, our commitment to SKF Care principles and our approach with rotating equipment performance (REP).

Sustainability

Sustainability challenges such as climate change, material use, energy demand, water use and health and safety drive new customer requirements and legislation. SKF was founded based on an innovation which enabled a massive increase in energy efficiency and reliability for industry. Ever since, SKF has added new technologies which increase reliability and uptime, reduce waste and consequently decrease the CO₂ and environmental footprint of the Group's and customers' operations.

In SKF we want to integrate sustainability in all our activities – in the products, services and customer solutions we provide. We apply life-cycle thinking to improve sustainability performance in our customer solutions, considering the selection of materials, using efficient production processes, optimising the function during customer use, and preparing for remanufacturing or recycling when the product has reached its end of life.

Rotating equipment performance

With SKF approach to optimizing rotating equipment performance, the objective is to maximize reliability and output from industrial equipment and production processes while driving down the total cost of ownership. Whether our customers want to solve a specific rotating equipment problem, increase asset or plant performance or improve overall maintenance efficiency, SKF is the reliable partner. With access to application insights together with the right products, connected technologies and flexible business models, we at SKF can help our customers get the performance they are looking for from their rotating equipment. Contact SKF for more information.

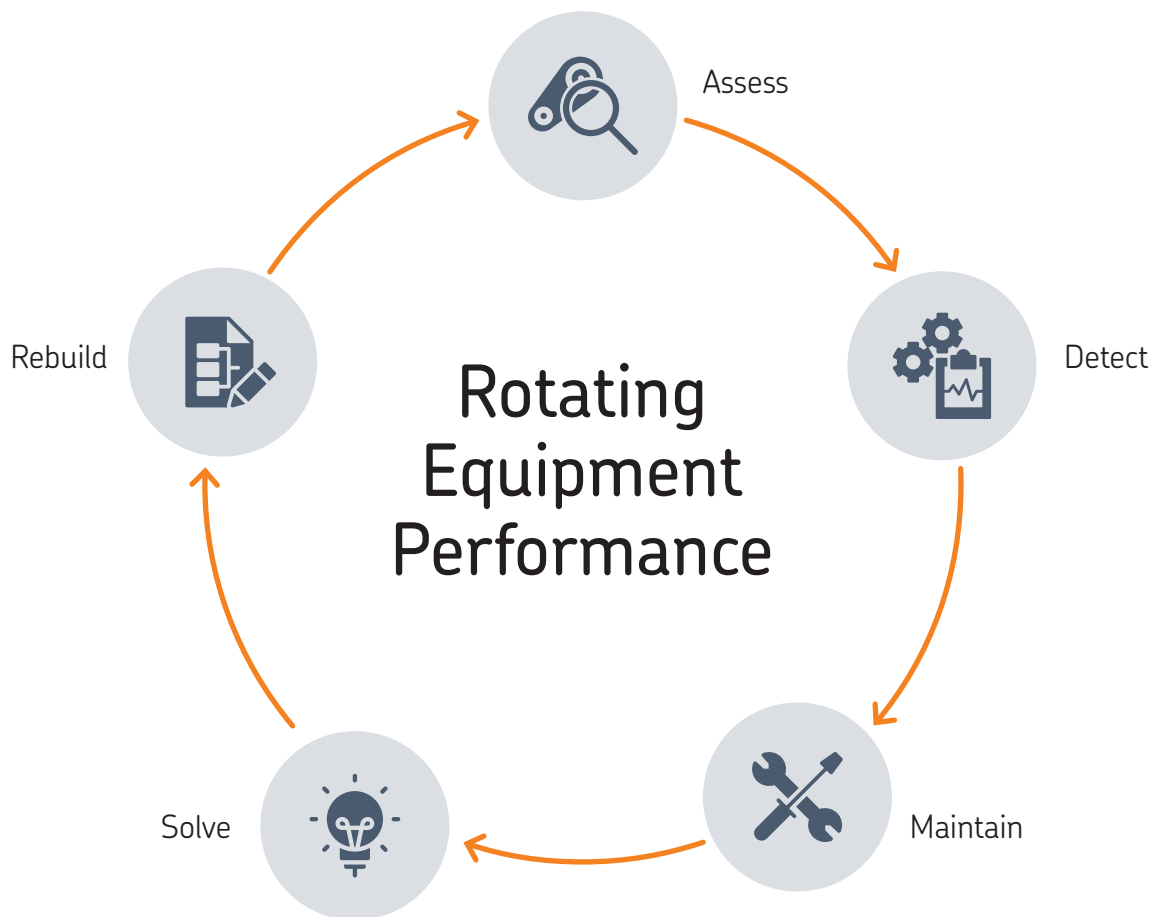

SKF Care

Our ambition and strategy is to create positive impact through the business we do and the way we do our business.

This is for the benefit of our business partners, customers, our employees, the natural environment and the communities around us. What we do creates shared value across all these perspectives:

The environmental perspective is about continually reducing the environmental impact from the Group's operations, as well as actions to significantly improve customers' environmental performance through the products, solutions and services that SKF supplies.

The business perspective is about customer focus, financial performance and returns for shareholders – with the highest standards of ethical behaviour.

The employee perspective is about ensuring a safe work environment and promoting health, education and the well-being of employees at SKF and in the supply chain.

The community perspective is about making positive contributions to the communities in which we operate and guides us to run our business in a way that supports positive development.

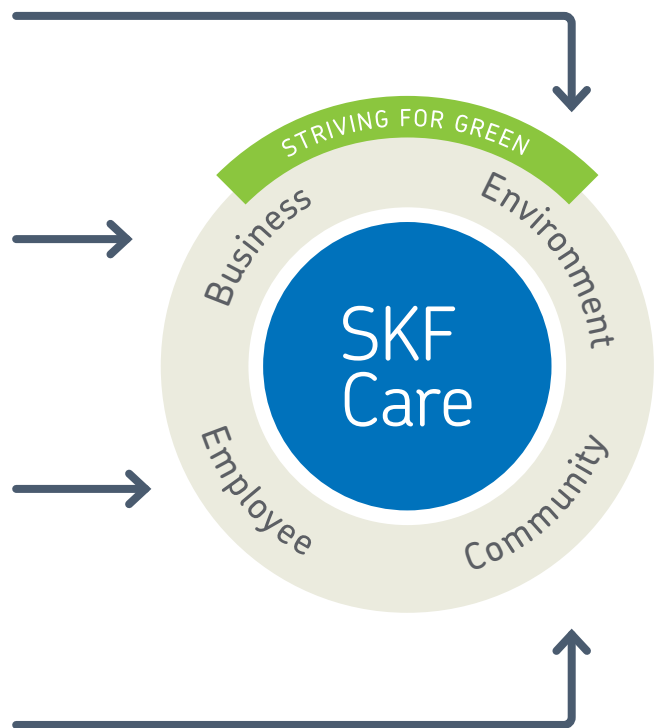

Foreword

SKF Aerospace highlights

SKF Aerospace serves all the industry players, from the Original Equipment Manufacturers (OEM) to the Maintenance Repair Overhaul (MRO) companies and supports major fixed-wing, helicopter, and engine and gearbox programmes, with:

- Airframe structural and flight control solutions
- Aircraft engine, gearbox, transmission and accessory solutions
- Many more Aerospace solutions, including Aerospace sealing solutions, Thin section bearings, Customized specialty ball solutions and Aerospace elastomeric and damping solutions

Based on SKF knowledge, supported by our long-standing experience in the industry and worldwide exposure to customers' needs with both a global and local presence (with manufacturing sites in France, USA, UK and Italy), SKF answers the critical challenges of the aerospace industry, including increasing air traffic, energy prices and environmental impacts.

SKF Aerospace delivers highly engineered standard parts, customized solutions, and services for airlines, aircraft and engine manufacturers. These solutions are the result of SKF's extensive experience and close cooperation between SKF and the customer's application experts. SKF provides total solutions over the full bearing life cycle, including design, testing and partnership.

SKF research and development focus on the needs of current and future generations of helicopters, aeroplanes, drones, engines and more, providing reduced weight and maintenance, improved pilot ergonomics and control simplicity, as well as accuracy and reliability for long service life.

Advanced development and manufacturing capabilities

To meet increasingly demanding program requirements, SKF is taking a big, exciting step forward with Centres of Excellence that offer advanced development capabilities. With these new state-of-the-art facilities for prototyping and testing, SKF is able to accelerate new product development and speed up time to market.

SKF manufacturing excellence achieves high quality and optimum performance for aerospace products with state of the art and digitalized manufacturing capabilities, as well as continuous improvement and Six Sigma methodologies. This means that you can look forward to

even more speed, efficiency and cost-effectiveness – from design and engineering to manufacturing and delivery.

SKF has approvals to AS9100 and EN9100¹⁾ (including ISO 9001), EASA Part 21G, ISO 45001 and OHSAS 18001, ISO 14001 and ISO 50001 as well as numerous individual process approvals from customers.

Main special processes are also Nadcap certified.

Contact SKF for more information.

The product portfolio of SKF Group at the service of aerospace industry needs

In addition to SKF Aerospace portfolio presented in this catalogue, other SKF products can be supplied by SKF Aerospace, including:

- **SKF rolling bearings (industrial bearings)**

Download a PDF of the catalogue at [skf.com/go/17000](https://www.skf.com/go/17000)

- **SKF super precision bearings**

To download a PDF document of SKF super precision bearings catalogue, go to https://www.skf.com/binaries/327-129877/0901d19680495562-Super-precision-bearings-catalogue---13383_2-EN.pdf#cid-129877

- **SKF slewing ring bearings**

To download a PDF document of SKF slewing ring bearings catalogue, go to https://www.kaydonbearings.com/downloads/catalog390/Kaydon_Catalog_390.pdf and <https://www.skf.com/binaries/307-513670/0901d196809590fe-Slewing-bearings.pdf#cid-513670>

Such products can be supplied with the relevant SKF Aerospace quality management, including certifications, inspections, and customizations.

¹⁾ AS are American standards, EN are European standards

Catalogue contents

This catalogue contains information about SKF products for the aerospace industry. SKF supplies:

- Airframe bearings, typically used in aerospace structures:
 - Standard and customized journal bearings
 - Standard and customized rolling bearings (using different rolling element technologies including SKF Aerospace precision rolling elements)
 - Standard and customized spherical plain bearings
 - Standard and customized rod ends
 - Engineered composite solutions
 - Engineered needle roller bearings
 - Engineered pulleys

You can find detailed information on these products in Section 1 of this catalogue.

- Aeroengine custom-designed rolling bearings, typically used in engine main-shafts and gearboxes, helicopter drivetrains, and accessory equipment solutions. They can use different rolling element technologies including SKF Aerospace precision rolling elements.

You can find an overview in Section 2 of this catalogue.

- Other aerospace solutions:
 - Aerospace Sealing Solutions, including rubber seals moulded and machined, carbon seals, and rings
 - Aerospace elastomeric and damping solutions
 - Aerospace thin section bearings
 - Aerospace specialty and engineered balls

You can find an overview in Section 3 of this catalogue.

Visit skf.com or contact SKF to learn more about aerospace products and solutions.

The information in this catalogue reflects SKF's state-of-the-art technology and capabilities as of the day of printing. The information herein may differ from that shown in earlier catalogues because of redesign, technological developments or revised calculation methods. SKF reserves the right to continually improve its products with respect to materials, design and manufacturing methods, some of which are driven by technological developments and standard evolutions.

How to use the catalogue

For each section of the catalogue, the following information is provided:

Principles of bearing selection

This part is marked with blue bars at the page edge. It provides general relevant information about:

- Available bearing types and sizes
- Relevant bearing data (materials, surface treatments, lubrication, sealing ...)
- Information about interfaces and bearing handling requirements

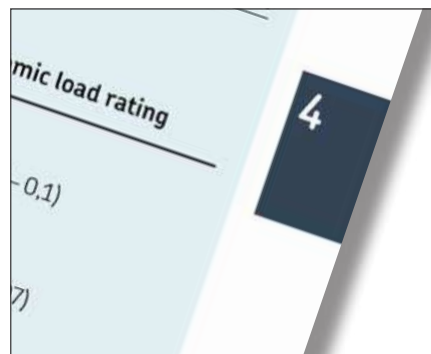

Product tables

Dedicated to standard products, these tables provide all required dimensions (metric/inch) and required information, such as standard references, dimensions, loads, clearance, or torque values. Consequently, it enables customers to find all design information needed for bearing selection.

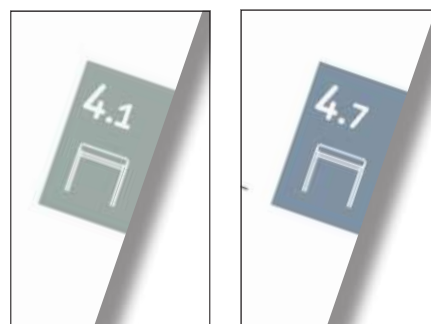

Metric

Inch

Indexes

The product index and text index are marked with grey bars. The product index lists series designations, relates them to the bearing type, and guides you to the relevant product section and product table. The text index lists entries in alphabetical order, and helps you locate specific information quickly.



Use case: Select a bearing for an application

If you are unsure whether you have adequate knowledge or experience to select a bearing that best suits your application requirements, you will probably find it helpful to consult the *Bearing selection process* on **page 28** and in each product chapter.

If you are an experienced bearing expert, go directly to the section for the relevant bearing type, browse the product tables for the required size, and then look at additional details and information on more specific variants in the text part preceding the product tables.

Use case: Find details of a known bearing

The easiest way to find detailed information about a bearing for which you have the designation is to use the product index, **page 487**. Compare the initial characters in a bearing designation with the entries in the product index. Each entry specifies the related bearing type, and the relevant product section and product table. To understand the product series used in a bearing designation, go to the text index, **page 487**, locate the entry for the suffix and follow the reference to the relevant product section where you can find detailed information.

If the bearing type is known, it is also possible to go directly to the relevant product chapter. Use the table of contents to locate information easily. The designation system is given in the product tables and the relevant cross-references to standards are given at the end of each product chapter.

Use case: Find information about a legacy bearing

SKF legacy series and bearings compliant to legacy standards can still be supplied. For more information, look into the list of *Legacy products* and *Legacy standards* in each relevant product chapter, searching by the bearing basic designation.

For legacy products with equivalent designations from both SKF Aerospace France and SKF Aerospace U.K. Limited, SKF uses a cross-reference designation system. **Table 16 page 151** provides the cross-reference for the relevant self-lubricating spherical plain bearings and **table 9 page 295** provides the cross-reference for the relevant self-lubricating spherical plain bearing rod ends. In these tables, search for the legacy basic designation to find the relevant cross-reference designation and the related product table. The **Product index page 487** can also be used. Search for the initial characters of a legacy bearing to find the related cross-reference.

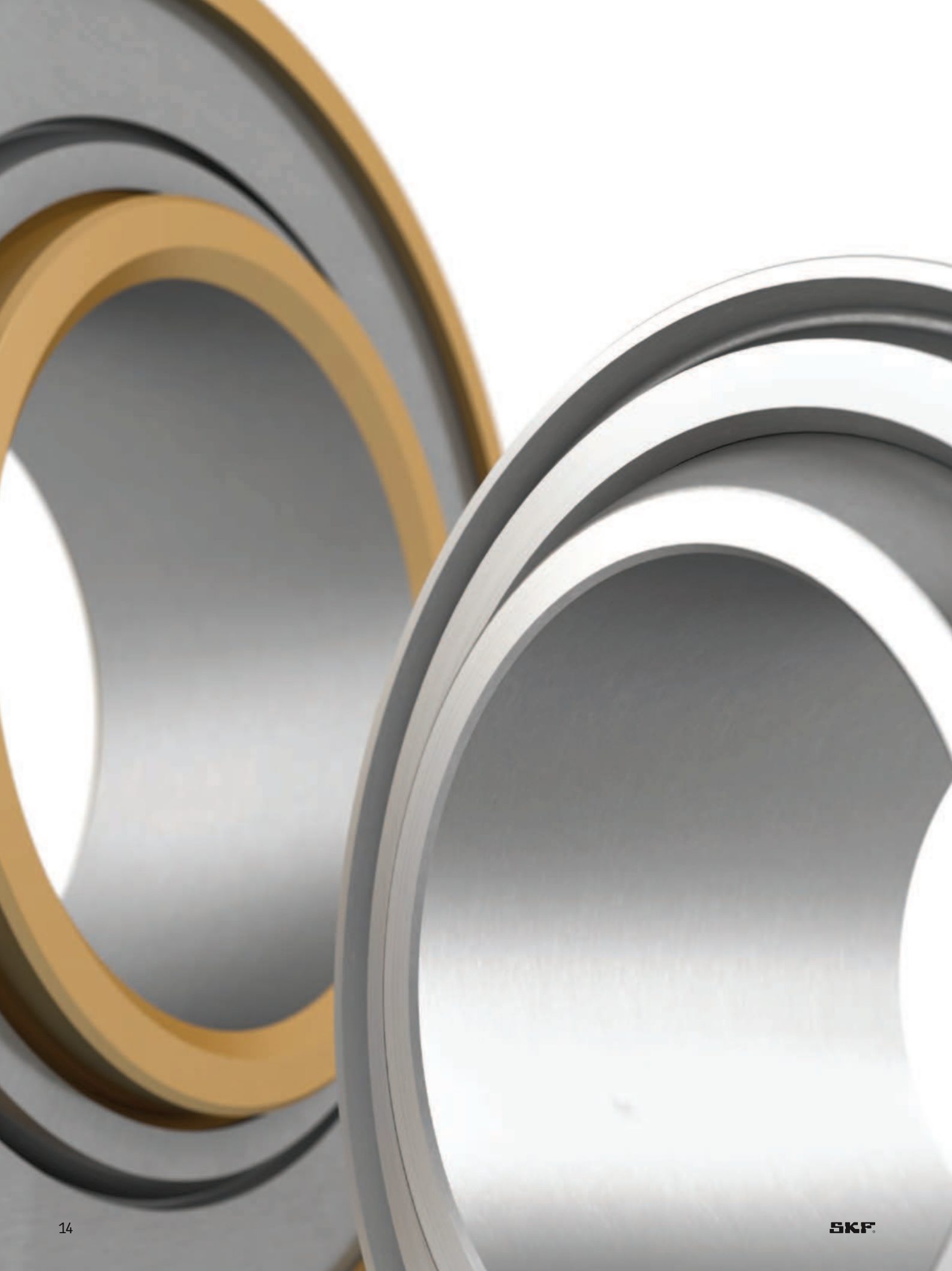

A Airframe solutions

Bearing types	16
Rolling bearings	16
Spherical plain bearings	18
Rod ends	22
Self-lubricating journal bearings	25
Airframe standard bearings selection process	27
Customized and engineered bearings	27
Basic bearing type selection guide	28
1 Rolling bearings	30
2 Spherical plain bearings	126
3 Rod ends	280
4 Self-lubricating journal bearings	390
5 Engineered pulleys	428
6 Engineered needle bearings	434
7 Engineered composite solutions	438

SKF supplies standard, customized and fully engineered airframe solutions.

With the widest range of airframe standard products, SKF can meet the most demanding application requirements and supply bearings compliant to the most common airframe standards, including international EN or AS standards, and leading customer standards.

Airframe solutions are used widely in aircraft structures. They can be found in many applications including:

- Landing gears
- Flight controls
- Actuators, attachment points and hinges
- Doors
- Helicopter rotors

SKF Aerospace supplies inch and metric bearings in different sizes and types with a wide range of design options, including different materials, surface treatments, lubrication and sealing solutions.

SKF Aerospace also supports customers with its engineering expertise and testing capabilities from investigation to qualification.

Bearing types

SKF Aerospace supplies various types of airframe bearings:

- Rolling bearings (single or double row ball or roller bearings)
- Spherical plain bearings (metal-to-metal or self-lubricating)
- Rod ends (using rolling bearings or spherical plain bearings)
- Self-lubricating journal bearings

Rolling bearings

Airframe rolling bearings are full complement bearings (i.e. bearings without a cage and with a full complement of rolling elements) that enable rotational movements with minimal friction.

They support high loads, guide rotating components precisely and accommodate oscillating movements or a low number of complete rotations at low rotational speed. Some bearing types can compensate for misalignment between the shaft and housing bore.

When an attachment solution is needed, airframe rolling bearings can be integrated into rod end bodies. Refer to *Rod ends* **page 280**.

The SKF rolling bearing standard assortment is comprised of:

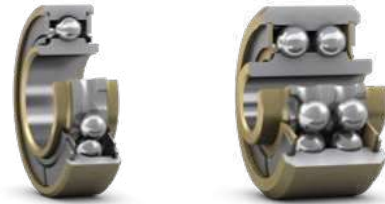

Deep groove ball bearings
1 and 2 rows



Self-aligning ball bearings
1 and 2 rows

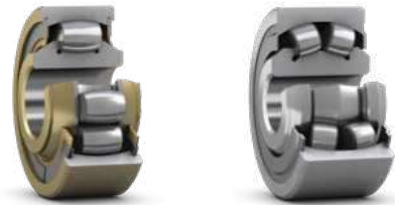

Spherical roller bearings
1 and 2 rows



Bearings with
self-aligning rings

Airframe rolling bearings can use different rolling element technologies, including SKF Aerospace precision specialty balls.

As a leading manufacturer of precision specialty balls, SKF provides balls in a wide range of sizes, materials and tolerances to meet your application requirements.

SKF can also provide specialty balls for various applications including fluid control, linear guides, ball screws, or ball transfer units.

For more information, see **table 1** for metric bearings, **table 2** for bearings with inch dimensions and refer to *Rolling Bearings* **page 30** and *Aerospace specialty and engineered balls* **page 468**.

Table 1













SKF rolling bearings, metric dimensions							
Type		Number of rows	Standard	SKF series	Table number	Page	
Deep groove ball bearing		Single	–	JN..	1.1	52	
			EN 3284, EN 3285, EN 3286	JNA..	1.2	54	
			EN 3045, EN 3046, EN 3047	–	T..	1.3	56
		Double	EN 3281, EN 3282, EN 3283	TA..	1.4	58	
			EN 4033	–	AG..	1.5	60
			–	AGN...	1.6	62	
Deep groove ball bearing with self-aligning ring		Single	EN 3059, EN 3060, EN 3061	TRCE..	1.7	64	
			EN 4041	TRCEI..	1.8	66	
Self-aligning ball bearing		Double	EN 3287, EN 3288, EN 3289	KN..	1.9	68	
			EN 4034	KNRCE..	1.10	70	
Spherical roller bearing		Single	EN 3053, EN 3054, EN 3055	K..F, KN..F, K..FE..	1.11	72	
			EN 3290, EN 3291, EN 3292	SP1, KN..FE..SP1	1.12	74	
		Double	–	KNA..F	1.13	76	
				K..D			

Table 2

SKF rolling bearings, inch dimensions						
Type		Number of rows	Standard	SKF series	Table number	Page
Deep groove ball bearing		Single	AS 27640	KP.., KP..L	1.14	78
			AS 27641	KP..A	1.15	80
			AS 27642	KP..B	1.16	84
		Double	–	KP..SP.., KP..A..SP.., KP..L..SP..	1.17	90
			AS 27646	B500..	1.18	92
			AS 21428	–	B5500..	1.19
	Double	AS 27644	DPP..	1.20	98	
		AS 27647	DW.., DW..K2, DW..K	1.21	100	
		–	–	–	–	–
Deep groove ball bearing with self-aligning ring		Single	AS 27648	KP..BS	1.22	102
Self-aligning ball bearing		Single	AS 27645	KSP.., KSP..A, KSP..L	1.23	106
			–	KSP..SP.., KSP..A..SP..	1.24	110
		Double	–	KN..	1.25	112
			AS 27643	DSP..	1.26	114
Spherical roller bearing		Single	–	DSRP..	1.27	116

Spherical plain bearings

Airframe spherical plain bearings support high loads, enable multi-directional oscillation at relatively low speed. They can compensate for misalignment between the shaft and housing bore.

Airframe spherical plain bearings can be made with a greased metal-to-metal spherical contact (MM bearings) or with a self-lubricating liner (SL bearings).

When an attachment solution is needed, airframe spherical plain bearings can be supplied as part of a rod end assembly. Refer to *Rod ends*, **page 280**.

The SKF spherical plain bearing standard assortment is comprised of:



SL¹) bearings swaged



SL¹) bearings pre-staked



SL¹) bearings swaged high misalignment



MM²) bearings slotted



MM²) bearings swaged



MM²) bearings split



MM²) bearings swaged high misalignment

For more information, see **table 3** for metric metal-to-metal bearings, **table 4** for metal-to-metal bearings with inch dimensions, **table 5** for metric self-lubricating bearings, **table 6** for self-lubricating bearings with inch dimensions and refer to *Spherical plain bearings*, **page 126**.

¹) SL = Self-lubricating
²) MM = Metal-to-metal

Table 3

SKF metal-to-metal spherical plain bearings, metric dimensions





Design		Variant	Standard	SKF series	Table number	Page
Loader slot		EN	EN 2336, EN 2588	GE	2.1	156
		SKF	–	GL	2.2	160
		High load	–	GLS...RTG	2.3	164
		Wide	–	GT	2.4	166
Swaged		Light	EN 2335	MA	2.5	168
		Narrow	–	ME	2.6	172
		Wide	–	ML	2.7	176
		High misalignment	–	MT	2.8	180
Split inner ring		SKF	–	2 PL	2.9	182

Table 4

SKF metal-to-metal spherical plain bearings, inch dimensions





Design		Variant	Standard	SKF series	Table number	Page
Loader slot		Wide	–	GT	2.10	184
Swaged		Narrow	AS 21154, AS 21155	ME	2.11	186
		Narrow	EN 6046	ENE	2.12	190
		Wide	–	ML	2.13	194
		Wide	EN 4265, EN 4266	ENL	2.14	198
		High misalignment	–	MT	2.15	202
		AS	AS 81936/1, AS 81936/2	QXMB	2.16	206
Split inner ring		SKF	–	2 PL	2.17	210

Table 5

Self-lubricating spherical plain bearings, metric dimensions

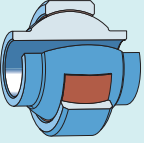



Figure	Variant	Standard	SKF series	Cross-reference to legacy SKF Aerospace France designation system Lons-le-Saunier (formerly known as SARMA)	Cross-reference to legacy SKF Aerospace U.K. Limited designation system Clevedon (formerly known as AMPEP)	Table number	Page
	Light	EN 3048, EN 4037	LEN..	XRA..	11C..N.. (not plated) 11F..N.. (chromium plated sphere)	2.18	214
	Narrow	EN 2584, EN 4038	NEN..	XRE..	11C..W.. (not plated) or 11F..W.. (chromium plated sphere) for bore code 5 and 22 11C..N.. (not plated) or 11F..N.. (chromium plated sphere) for bore code 6 and 10 11C..E.. (not plated) or 11F..E.. (chromium plated sphere) for bore code 8 and ≥ 12 (except 22)	2.19	216
	Wide	EN 2585, EN 4039	WEN..	XRL..	11C..E.. (not plated) or 11F..E.. (chromium plated sphere) for bore code 5 11C..W.. (not plated) or 11F..W.. (chromium plated sphere) for bore code ≥ 6	2.20	220
	High misalignment	EN 4040	HMEN..	RL..SP.. (stepped design inner ring)	11E..H (blended design inner ring)	2.21	224
	High misalignment	–	XRT..	–	–	2.22	226
	Pre-staked	–	XRL..FR	–	–	2.23	228

Table 6

Self-lubricating spherical plain bearings, inch dimensions

Figure	Variant	Standard	SKF series	Cross-reference to legacy SKF Aerospace France designation system Lons-le-Saunier (formerly known as SARMA)	Cross-reference to legacy SKF Aerospace U.K. Limited designation system Clevedon (formerly known as AMPEP)	Table number	Page
	Narrow controlled clearance	–	SN..ZT	–	–	2.24	230
	Narrow	NSA 8134, NSA 8136	SN..	–	–	2.25	232
	Narrow	AS 14101, AS 14104	NAS..	XRE..	11HN.. (inner ring sphere surface coated) 11BN..	2.26	236
	Narrow lined bore	AS 81820/1, AS 81820/4	NAS..A..	XRE..A..	11LHN.. (inner ring sphere surface coated) 11LBN..	2.27	240
	Wide	NSA 8135, NSA 8137	SW..	–	–	2.28	244
	Wide	AS 14102, AS 14103	WAS..	XRL..	11HW.. (inner ring sphere surface coated) 11BW..	2.29	248
	Wide lined bore	AS 81820/2, AS 81820/3	WAS..A..	XRL..A..	11LHW.. (inner ring sphere surface coated) 11LBW..	2.30	254
	High misalignment	–	SH..	–	–	2.31	256
	High misalignment	–	11..H..	–	–	2.32	258
	High misalignment	–	XRT..	–	–	2.33	260
	Pre-staked	–	XRL..FR	–	–	2.34	264

A

Rod ends

Rod ends provide the same functions as the bearing they use together with an easy attachment and positioning solution to the application.

The SKF rod end standard assortment is comprised of:



Rod ends with integrated self-aligning ball bearings



Rod ends with inserted spherical plain bearings (SL¹) or MM²)



Rod ends with integrated MM spherical plain bearings

Refer to rolling bearing and spherical plain bearing chapters for more information.

For more information, see **table 7** for metric bearings, **table 8** for bearings with inch dimensions and refer to *Rod ends* **page 280**.

Table 7

SKF rod ends, metric dimensions

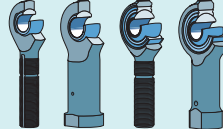
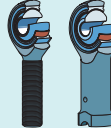
Type		Thread	Standard	SKF rod end series	SKF bearing series	Cross-reference to legacy SKF Aerospace France designation system Lons-le-Saunier (formerly known as SARMA)	Cross-reference to legacy SKF Aerospace U.K. Limited designation system Clevedon (formerly known as AMPEP)	Table number	Page
Ball bearing rod ends		Integrated External	EN 3541, EN 4036	C..MJ, CN..MJ/N/A		–	–	3.1	296
		Integrated External	–	C..M, CN..M, CN..M..SP1	N/A	–	–	3.2	298
Metal-to-metal rod ends		Integrated External	–	EM..	N/A	–	–	3.3	300
		Inserted External	–	EMJ/ML..	ML..R metric	–	–	3.4	302
		Inserted External	–	EMJ/MT..	MT..R metric	–	–	3.5	304
		Integrated Internal	–	EF..	N/A	–	–	3.6	306
		Inserted Internal	–	EFJ/ML..	ML..R metric	–	–	3.7	308
		Inserted Internal	–	EFJ/MT..	MT..R metric	–	–	3.8	310
Self-lubricating rod ends		Inserted External	EN 2498, EN 4198	EMA..	HMEN..R metric	–	–	3.9	312
		Inserted External	–	EMJ/RL..	WEN..R metric	–	–	3.10	314
		Inserted External	–	EMJ/RT..	XRT..R metric	–	–	3.11	316
		Inserted Internal	–	EFJ/RL..	WEN..R metric	–	–	3.12	318
		Inserted Internal	–	EFJ/RT..	XRT..R metric	–	–	3.13	320

A

Table 8

SKF rod ends, inch dimensions

Type		Thread	Standard	SKF rod end series	SKF bearing series	Cross-reference to legacy SKF Aerospace France designation system Lons-le-Saunier (formerly known as SARMA)	Cross-reference to legacy SKF Aerospace U.K. Limited designation system Clevedon (formerly known as AMPEP)	Table number	Page
Ball bearing rod ends		Integrated External	–	CN..SP	N/A	–	–	3.14	322
		Integrated External	EN 4156, EN 4157	CN..	N/A	–	–	3.15	326
		Integrated External	AS 21151	REP..M, RA..M, N/A RAP..M	–	–	–	3.16	332
		Integrated Internal	AS 21153	REP.., REP..F., N/A REPB..N..	–	–	–	3.17	334
Metal-to-metal rod ends		Inserted External	–	EMJ/..ML..R	ML..R inch	–	–	3.18	336
		Inserted External	–	EMJ/..MT..R	MT..R inch	–	–	3.19	338
		Inserted Internal	–	EFJ/..ML..R	ML..R inch	–	–	3.20	340
		Inserted Internal	–	EFJ/..MT..R	MT..R inch	–	–	3.21	342
Self-lubricating rod ends		Inserted External	AS 81935/1	MJ/WAS..	WAS..R inch, EWAS..R inch	UMJ/XRL..	12BM..	3.22	344
		Inserted External	AS 81935/4	MJ/NAS..	NAS..R inch, ENAS..R inch	UMJ/XRE..	12BNM..	3.23	346
		Inserted External	AS 81935/6	PHMJ/WAS..	WAS..R inch, EWAS..R inch	PHUMJ/XRL..	12CM..	3.24	348
		Inserted External	AS 81935/8	PHMJ/NAS..	NAS..R inch, ENAS..R inch	PHUMJ/XRE..	12CNM..	3.25	350
		Inserted External	NSA 8143	R..M..	SW..G inch	–	–	3.26	352
		Inserted External	–	EMJ/RL..R	WAS..R inch	–	–	3.27	354
		Inserted External	–	EMJ/RT..R	XRT..R inch	–	–	3.28	356
		Inserted Internal	AS 81935/2	FJ/WAS..	WAS..R inch, EWAS..R inch	UFJ/XRL..	12BF..	3.29	358
		Inserted Internal	AS 81935/5	FJ/NAS..	NAS..R inch, ENAS..R inch	UFJ/XRE..	12BNF..	3.30	362
		Inserted Internal	AS 81935/7	PHFJ/WAS..	WAS..R inch, EWAS..R inch	PHUFJ/XRL..	12CF..	3.31	366
		Inserted Internal	AS 81935/9	PHFJ/NAS..	NAS..R inch, ENAS..R inch	PHUFJ/XRE..	12CNF..	3.32	370
		Inserted Internal	NSA 8149	R..F..	SW..G inch	–	–	3.33	374
		Inserted Internal	–	EFJ/RL..R	WAS..R inch	–	–	3.34	378
Inserted Internal	–	EFJ/RT..R	XRT..R inch	–	–	3.35	380		

Self-lubricating journal bearings

Airframe journal bearings are “maintenance-free” and compact solutions that enable low friction rotation and sliding guidance by providing a self-lubricating and wear-resistant surface, while limiting constraints on the assembly when replacement is required.

The SKF journal bearing standard assortment is comprised of plain and flanged bearings.

For more information, see **table 9** for metric bearings, **table 10** for bearings with inch dimensions and refer to *Journal bearings*, **page 390**.



Plain journal bearings



Flanged journal bearings

Table 9

SKF self-lubricating journal bearings (metric dimensions)

Shape	Shell material	Standard	Liner	SKF series	Table number	Page
Plain 	Corrosion-resistant steel	EN 2287	X1	13C..Z	4.1	404
		EN 2287	Fiberslip	..K	4.1	404
		–	X1	13D..Z	4.2	406
	Aluminium alloy	EN 2285	X1	13C..Z	4.1	404
		EN 2285	Fiberslip	..K	4.1	404
		–	X1	13D..Z	4.2	406
Flanged 	Corrosion-resistant steel	EN 2288	X1	13C..F	4.3	408
		EN 2288	Fiberslip	..F..K	4.3	408
		–	X1	13D..F	4.4	410
	Aluminium alloy	EN 2286	X1	13C..F	4.3	408
		EN 2286	Fiberslip	..F..K	4.3	408
		–	X1	13D..F	4.4	410

Table 10

SKF self-lubricating journal bearings (inch dimensions)

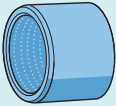
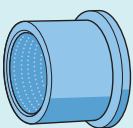
Shape	Shell material	Standard	Liner	SKF series	Table number	Page
Plain 	Corrosion-resistant steel	NSA 8145	X1	13A..Z..	4.5	412
		NSA 8145	Fiberslip	K..P	4.5	412
		AS 81934/1	X1	13B..Z..	4.6	414
	Aluminium alloy	EN 4536-2	X1	13E..Z..	4.7	416
		NSA 8146	X1	13A..Z..	4.5	412
		NSA 8146	Fiberslip	K..P	4.5	412
Flanged 	Corrosion-resistant steel	NSA 8147	X1	13A..Z..	4.8	418
		NSA 8147	Fiberslip	K..F..P	4.8	418
		AS 81934/2	X1	13B..F..	4.9	420
	Aluminium alloy	EN 4537-2	X1	13E..F..	4.10	422
		NSA 8148	X1	13A..F..	4.8	418
		NSA 8148	Fiberslip	K..F..P	4.8	418
AS 81934/2	X1	13B..F..	4.9	420		
	EN 4535-2	X1	13E..F..	4.10	422	

Airframe standard bearings selection process

If you are looking for a known product, according to its standard for example, or if you are an experienced bearing expert, go directly to the relevant product chapter and product table.

For help in selecting the appropriate bearing type, refer to *Basic bearing type selection guide*, **page 28**, and follow the selection process given for each standard airframe product:

- 1 Determine the relevant bearing type
- 2 Determine the allowable bearing size
- 3 Determine the required bearing load carrying capability
- 4 From the product tables, find a suitable bearing based on the above steps
- 5 Choose all other required options including materials, surface treatments, lubrication, sealing, etc.
- 6 Consider bearing handling requirements for mounting, dismounting and storage

If the standard SKF range of bearings does not meet your specific needs, contact SKF for a customized design solution, as described in *Customized products*.

Refer to the relevant product chapter for more information.

Customized and engineered bearings

SKF supplies customized and engineered bearings to meet specific airframe application requirements. These solutions are the result of SKF's extensive experience and close cooperation between SKF and the customer's application experts.

SKF provides total solutions over the full bearing life cycle, including design, testing and partnership.

Customized products per bearing type are presented in the individual product sections. Other engineered airframe solutions include:

- Pulleys (**page 428**)
- Needle bearings (**page 436**)
- Composite solutions (**page 438**)

For more information, contact SKF via: skf.com/go/aero

Basic bearing type selection guide

Based on their key characteristics (**table 11**), an initial decision must be made between using a standard SKF Aerospace self-lubricating journal bearing, spherical plain bearing, or rolling bearing.

A

Table 11

Basic bearing type selection guide

Application requirement	Rolling bearing	Spherical plain bearing		Self-lubricating journal bearing
		Metal-to-metal	Self-lubricating	
Load capacity vs compactness	Good	Very good	Very good	Excellent
No load starting rotational torque	Low	Low	Moderate	Moderate
No load starting swivelling torque	Low to moderate (for bearings with misalignment capability)	Low	Moderate	N/A
Loaded rotational frictional moment	Very low	Moderate	Low	Low
Loaded swivelling frictional moment	Low to moderate (for bearings with misalignment capability)	Moderate	Low	N/A
Lubrication	Greased-for-life	Greased-for-life or need for relubrication depending on application requirements	Maintenance-free	Maintenance-free
Typical motion	From oscillation > 1° to low number of complete revolutions at low to moderate speed	Oscillation at low speed	Oscillation at low to moderate speed	Oscillation and/or sliding of shaft at low to moderate speed
Typical dynamic failure mode	Surface failure	Progressive wear and seizing	Progressive wear	Progressive wear

When an attachment and positioning solution to the application is needed, rod ends can be used.

For more information, refer to the relevant product chapter.

For more solutions, refer to the customized and engineered bearing sections in the relevant product chapter and contact SKF via: skf.com/go/aero.

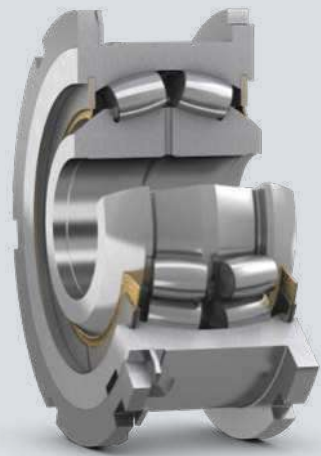

Rolling bearings

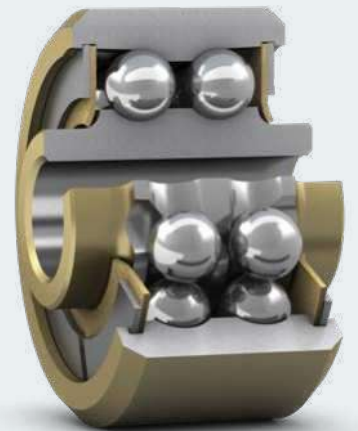

1 Rolling bearings

Bearing designs and variants	32	Product tables	
Variants	34	Metric dimensions	52
Bearing materials	34	1.1 Deep groove ball bearing single row	52
Surface treatments	34	1.2 Deep groove ball bearing single row, EN 3284, EN 3285, EN 3286, EN 3045, EN 3046, EN 3047	54
Sealing and shielding solutions	34	1.3 Deep groove ball bearing single row	56
Rod ends	34	1.4 Deep groove ball bearing single row, EN 3281, EN 3282, EN 3283, EN 4033	58
Customized bearings	34	1.6 Deep groove ball bearing double row	60
		1.6 Deep groove ball bearing double row, EN 3056, EN 3057, EN 3058	62
Rolling bearing selection for airframe applications	35	1.7 Deep groove ball bearing with self-aligning ring single row, EN 3059, EN 3060, EN 3061	64
Performance and operating conditions	35	1.8 Deep groove ball bearing with self-aligning ring single row, EN 4041	66
Bearing selection process	36	1.9 Self-aligning ball bearing double row, EN 3287, EN 3288, EN 3289	68
Selecting bearing size and options	36	1.10 Self-aligning ball bearing double row, EN 4034	70
Bearing load carrying capability	37	1.11 Spherical roller bearing single row, EN 3053, EN 3054, EN 3055	72
Static load	37	1.12 Spherical roller bearing single row, EN 3290, EN 3291, EN 3292	74
Dynamic load rating	38	1.13 Spherical roller bearing double row	76
Lubrication	39		
Operating temperature	40	Inch dimensions	78
Sealing and shielding	40	1.14 Deep groove ball bearing single row, AS 27640	78
Friction and torque	41	1.15 Deep groove ball bearing single row, AS 27641	80
Bearing interfaces	42	1.16 Deep groove ball bearing single row, AS 27642	84
Selecting fits	42	1.17 Deep groove ball bearing single row	90
Axial location of bearing	42	1.18 Deep groove ball bearing single row, AS 27646, AS 21428	92
Bearing data	45	1.19 Deep groove ball bearing double row	96
Dimensions and tolerances	45	1.20 Deep groove ball bearing double row, AS 27644	98
Material	45	1.21 Deep groove ball bearing double row, AS 27647	100
Surface treatments	46	1.22 Deep groove ball bearing with self-aligning ring single row, AS 27648	102
Sealing and shielding	47	1.23 Self-aligning ball bearing single row, AS 27645	106
Internal clearance	47	1.24 Self-aligning ball bearing single row	110
Bearing handling	49	1.25 Self-aligning ball bearing double row	112
Mounting	49	1.26 Self-aligning ball bearing double row, AS 27643	114
Dismounting	50	1.27 Spherical roller bearing single row	116
Storage	50		
Customized products	51	Cross-reference	118
Legacy standards	51	Metric bearings	118
		Inch bearings	124

1 Rolling bearings

1

Airframe rolling bearings are full complement bearings (i.e. bearings without a cage and with a full complement of rolling elements) that enable rotation with minimal friction. They support high loads and guide rotating components precisely. Airframe rolling bearings accommodate radial loads (perpendicular to the shaft) and axial loads (along the shaft). They are designed to accommodate oscillating movements or a low number of complete rotations at low rotational speed.

Some bearing types can compensate for misalignment between the shaft and housing bore.

Airframe rolling bearings are used widely in aircraft structures. They can be found in many applications including:

- Flight controls
- Actuators, attachment points and hinges
- Doors
- Helicopter rotors

Bearing designs and variants

Commonly used airframe rolling bearing types are listed in **table 1** for metric bearings and in **table 2** for bearings with inch dimensions. In addition to this standard assortment, SKF supplies a variety of customized bearings, **page 51**.

Figure 1

Terminology

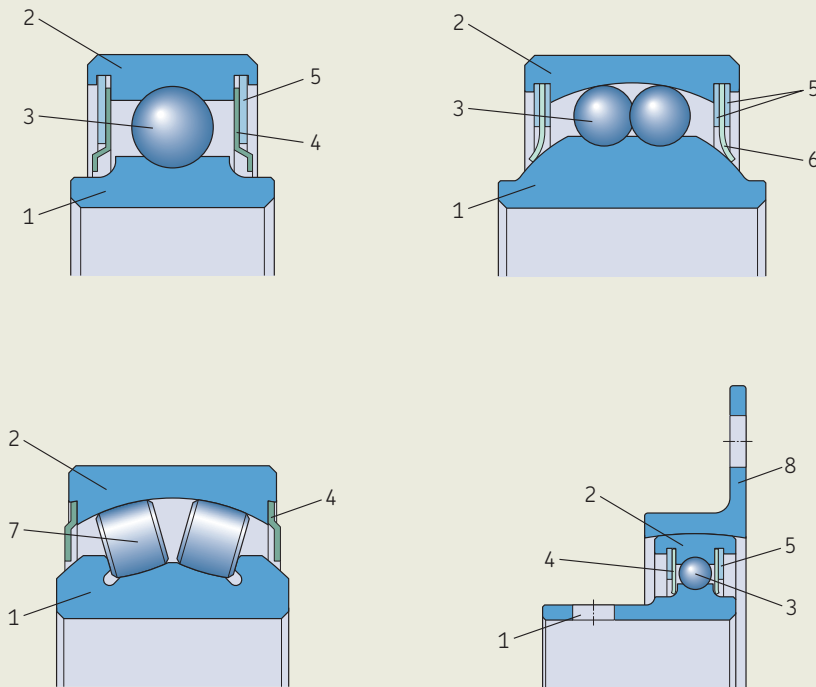

- 1 Inner ring
- 2 Outer ring
- 3 Ball(s)
- 4 Shields
- 5 Metal retainers
- 6 Seals
- 7 Roller(s)
- 8 Flange of self-aligning ring

Table 1

SKF rolling bearings, metric dimensions









Type		Number of rows	Standard	SKF series	Table number	Page	
Deep groove ball bearing		Single	–	JN..	1.1	52	
			EN 3284, EN 3285, EN 3286	JNA..	1.2	54	
			EN 3045, EN 3046, EN 3047	–	–	–	–
			–	T..	1.3	56	
		Double	–	TA..	1.4	58	
			EN 3281, EN 3282, EN 3283 EN 4033	AG..	1.5	60	
Deep groove ball bearing with self-aligning ring		Single	EN 3059, EN 3060, EN 3061	TRCE..	1.7	64	
			EN 4041	TRCEI..	1.8	66	
Self-aligning ball bearing		Double	EN 3287, EN 3288, EN 3289	KN..	1.9	68	
			EN 4034	KNRCE..	1.10	70	
Spherical roller bearing		Single	EN 3053, EN 3054, EN 3055	K..F, KN..F, K..FE.. SP1, KN..FE..SP1	1.11	72	
			EN 3290, EN 3291, EN 3292	KNA..F	1.12	74	
		Double	–	K..D	1.13	76	

Table 2

SKF rolling bearings, inch dimensions

Type		Number of rows	Standard	SKF series	Table number	Page
Deep groove ball bearing		Single	AS 27640	KP.., KP..L	1.14	78
			AS 27641	KP..A	1.15	80
			AS 27642	KP..B	1.16	84
			–	KP..SP.., KP..A..SP.., KP..L..SP..	1.17	90
		Double	AS 27646	B500..	1.18	92
			AS 21428	–	–	–
Deep groove ball bearing with self-aligning ring		Double	–	B5500..	1.19	96
			AS 27644	DPP..	1.20	98
			AS 27647	DW.., DW..K2, DW..K	1.21	100
Deep groove ball bearing with self-aligning ring		Single	AS 27648	KP..BS	1.22	102
Self-aligning ball bearing		Single	AS 27645	KSP.., KSP..A, KSP..L	1.23	106
			–	KSP..SP.., KSP..A..SP..	1.24	110
		Double	–	KN..	1.25	112
			AS 27643	DSP..	1.26	114
Spherical roller bearing		Single	–	DSRP..	1.27	116

Variants

Bearing materials

1

Standard bearing materials are:

- Bearing steel
- Corrosion-resistant steel for enhanced corrosion resistance

SKF also supplies bearings using various other material types and grades.

For additional information and options, refer to *Customized products* **page 51**.

Surface treatments

Surface treatments are used to adapt bearings to various application requirements, including:

- Enhanced corrosion resistance under specific environmental conditions
- Increased fretting resistance

For additional information and options, refer to *Surface treatments* **page 46**.

Sealing and shielding solutions

All standard rolling bearings are protected by either a:

- Non-contacting shield
- Contact seal

This is used to protect bearings against the ingress of external contaminants, keep the grease inside the bearing and prolong bearing service life

For additional information, refer to *Sealing and shielding* **page 40**.

Rod ends

Rolling bearings can be used as part of rod ends, see **figure 2**. Rod ends are used for easy attachment of a bearing to the airframe structure. For information about these products, refer to *Rod Ends* **page 280**.

Customized bearings

SKF supplies customized bearings to meet specific airframe application requirements. These solutions are the result of SKF's extensive experience and close cooperation between SKF and the customer's application experts

SKF provides total solutions over the full life cycle, including design, testing and partnership.

For additional information, refer to *Customized products* **page 51**.

Contact your regional SKF partner via: www.skf.com/go/aero



Figure 2. Rod end with integrated self-aligning ball bearing

Rolling bearing selection for airframe applications

Performance and operating conditions

The first step in the bearing selection process is to understand and document:

- Required performance
- Operating conditions and any assumptions made
- Any other application prerequisites

Basic selection criteria







Each bearing type displays specific design characteristics to accommodate a wide range of application conditions. The main factors to consider in order to select the most suitable bearing type based on application requirements are:

- Misalignment capability
- Compactness
- Load carrying capability (magnitude and direction)
- Rotational frictional moment

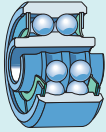
Table 3 provides quick guidance for most relevant selection criteria. Definitions are provided on the next page.

1

Table 3

Bearing types		Deep groove ball bearing		Self-aligning ball bearing		Spherical roller bearing		Deep groove ball bearing with self-aligning ring
								
Properties		Single row	Double row	Single row	Double row	Single row	Double row	Single row
Misalignment capability	Static	No	No	Good	Good	Good	Good	Good
	Dynamic	No	No	Good	Good	Good	Good	No
Compactness		Excellent	Moderately reduced compared to single row	Good	Moderately reduced compared to single row	Good	Moderately reduced compared to single row	Very good
Radial load carrying capability	Static and dynamic	Very good	Highly increased compared to single row	Good	Highly increased compared to single row	Excellent	Highly increased compared to single row	Good (depending on flange geometry)
Axial load carrying capability	Static	Good	Increased compared to single row	No	Good	Very good	Increased compared to single row	Good
	Dynamic	Good, must be combined with a higher radial load	Increased compared to single row	No	Good	Very good, must be momentary or intermittent and combined with a higher radial load	Increased compared to single row	Good, must be combined with a higher radial load
Low starting rotational torque		Excellent	Reduced performance compared to single row	Excellent	Reduced performance compared to single row	Good	Reduced performance compared to single row	Excellent

For specific application requirements, SKF Application Engineering services are available to support in the bearing selection process, perform complex calculations, and diagnose and solve bearing performance issues.

Misalignment capability

Table 3 provides an overview of the capability of various bearing types to accommodate misalignment. The different types of misalignment are explained in **table 4**.

Bearing types vary in their ability to compensate for misalignment between the shaft and housing. Values for the permissible misalignment angles are listed in the relevant product table.

Compactness

Often the boundary dimensions of a bearing are predetermined by the space available on the aircraft system. Typically, the shaft diameter determines the bearing bore diameter.

The bearing type impacts the size of the bearing. For the same outer diameter, double row bearings typically have larger widths than single row bearings.

Load carrying capability

All airframe bearings can accommodate radial loads.

Rolling bearings with rollers accommodate higher loads than same size bearings with balls as rolling elements.

Double row bearings accommodate higher loads than single row bearings of the same type.

Deep groove ball bearings are a common choice for applications with moderate axial loads. For higher axial loads spherical roller bearings are recommended.

Rotational frictional moment

Ball bearings have a lower rotational frictional moment than roller bearings.

The rotational frictional moment can be impacted by the sealing solution, refer to *Sealing and shielding* **page 40**.

Bearing selection process

Selecting bearing size and options

If you are looking for a known rolling bearing, according to its standard for example, or if you are an experienced bearing expert, use **table 1** and **2** to find the relevant product table.

For help in selecting the appropriate rolling bearing size and options, follow these steps:

- 1 Determine the suitable bearing type using the selection matrix **table 3**.
- 2 Determine the range of allowable interface dimensions for the bearing. Refer to *Compactness* **page 36**.
- 3 Determine the static radial and axial load requirements, refer to *Bearing load carrying capability* **page 37**.
- 4 From the product tables, find a bearing with sufficient static load carrying capability that best fits the required dimensions.

Example

When selecting a deep groove ball bearing for a maximum bearing size of 25,4 mm, a minimum shaft size of 6 mm, and a minimum static radial load carrying capability of 11 kN, then a JNA 8 single row deep groove ball bearing can be selected.

- 5 When compensation for misalignment is required, check whether the swivelling angle is sufficient.
- 6 If the bearing is subjected to dynamic loading conditions, refer to *Dynamic load rating* **page 38** in order to select a bearing that will achieve the required dynamic life.

If required, repeat above steps to determine a suitable bearing series and size.

Table 4

Types of misalignment

Static misalignment

There is an initial alignment error between the two supports of a shaft.

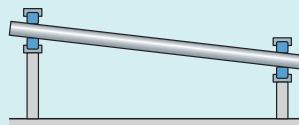

Shaft deflection creates misalignment between bearing inner and outer rings that is constant in magnitude and direction.

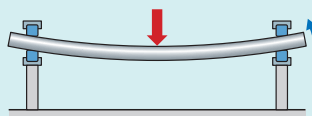

Dynamic misalignment

Varying shaft deflection creates misalignment between bearing inner and outer rings that is continuously changing in magnitude or direction.

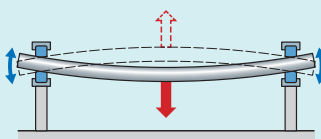

7 Verify other parameters or select suitable bearing variant:

- Select grease and verify operating temperature range. Refer to *Lubrication* page 39 and *Operating temperature* page 40.
- Select sealing or shielding solution. Refer to *Sealing and shielding* page 40.
- Verify starting torque. Refer to *Friction and torque* page 41.
- Verify internal clearances and bearing precision. Refer to *Internal clearance* page 47.
- Select materials and surface treatments. Refer to *Material* page 45 and *Surface treatments* page 46.
- Select fits and axial location conditions based on mating parts information. Refer to *Bearing interfaces* page 42.

If the standard SKF range of rolling bearings does not meet your specific needs, contact SKF for a customized design solution, as described in *Customized products* page 51.

Bearing load carrying capability

The aircraft loads applied on bearings are either static or dynamic, in the axial or radial direction, or with both axial and radial loads combined, see figure 3.

Static load

Static load can lead to permanent deformation of the bearing rolling elements or raceways, increased friction, and ultimately failure of the bearing if the applied load is above the bearing static load carrying capability.

It is therefore necessary to select a bearing with sufficiently high static load carrying capability.

Radial and axial static limit loads (C_s and C_a)

The radial static limit load, C_s and axial static limit load, C_a are defined respectively as the maximum radial and the maximum axial static load carrying capabilities of the bearing. Due to the high loads and oscillating movements, or low number of complete rotations at low rotational speed of airframe bearing applications, a total permanent deformation greater than the total permanent indent caused under C_0 load is acceptable at the most loaded rolling element. C_0 is defined as the basic radial static load which causes a total permanent indent on the raceway of 1/10 000 of the rolling element diameter.

Values for the axial static limit load, C_a and radial static limit load C_s are listed in the relevant product tables.

Radial and axial static ultimate loads

The radial and axial static ultimate loads are defined respectively as the maximum radial and the maximum axial static loads that can be applied on the bearing without causing cracks or failure of the rings or rolling elements.

Static ultimate loads are defined as 1,5 times the static limit loads:

$$\text{Radial static ultimate load} = 1,5 C_s$$

$$\text{Axial static ultimate load} = 1,5 C_a$$

Bearings exposed to this load level are no longer guaranteed to be fully functional and should be replaced.

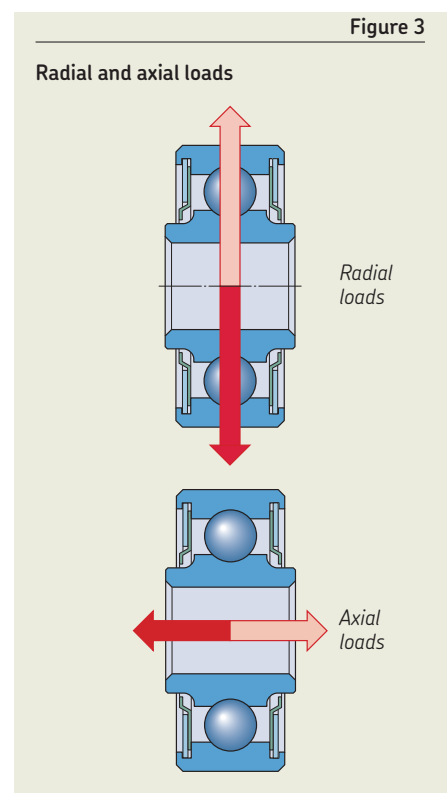

Combined loads

As a reminder, single row self-aligning ball bearings are not designed to carry axial loads and should only be subjected to radial loads. Therefore they do not operate under combined axial and radial loading.

If deep groove ball bearings are subjected to combined loads, the operating load must be compared to the axial and radial static limit load carrying capabilities, respectively.

This also applies to deep groove ball bearings with self-aligning ring, where the axial limit load is listed by the relevant product standards for a maximum allowable displacement on the application.

For all other rolling bearing types, when both radial and axial static loads are applied, the equivalent bearing radial static load, P_s must be determined and compared to the radial static limit load C_s .

P_s is defined as the equivalent radial static load, constant in magnitude and direction, acting radially on the bearing (**figure 4**).

When applied, the equivalent radial load would have the same influence on the bearing as the actual loads to which the bearing is subjected.

The equivalent load applied to the bearings is defined as:

$$P_s = F_r + Y_s F_a$$

Where

- P_s Equivalent radial static load [lbf/kN]
- F_r Radial component of the applied load [lbf/kN]
- F_a axial component of the applied load [lbf/kN]
- Y_s Axial load factor, depending on bearing type:
 - = 3,2 for double row self-aligning ball bearings
 - = 3,3 for single row spherical roller bearings
 - = 1,6 for double row spherical roller bearings

P_s should be less than or equal to C_s
e.g. $P_s \leq C_s$

Where

C_s = Radial static limit load [lbf/kN]

Dynamic load rating

Airframe bearings can be subjected to duty cycles that are the successive combinations of loads, oscillations or rotations experienced during the different operating conditions of the aircraft.

According to the MIL HDBK 1599 standard (for airframe rolling bearing applications), the dynamic load rating (D.L.r) is defined on the basis of a unidirectional radial load that will result in an average bearing life of 10 000 cycles at $\theta = 90^\circ$ oscillation (**figure 5**) before evidence of contact fatigue (spalling) occurs. By convention, SKF uses an oscillation angle $\gamma = \frac{\theta}{2}$ as defined in figure 5.

D.L.r is defined for a load fixed with respect to the inner ring, or to the outer ring.

Contrary to EN product standards, AS product standards define the dynamic load rating that the bearing must sustain. D.L.r values can be found in the relevant product tables.

However, in most aerospace applications, the applied dynamic operating load (P) differs from the dynamic load rating (D.L.r) for the bearing. It is therefore necessary to evaluate bearing life based on the applied load.

The load-life relationship given **page 39** can be used to calculate an estimation of the bearing life, L at any load, P .

Average bearing life, L_{50} means that 50% of a given group of bearings are expected to achieve the calculated life.

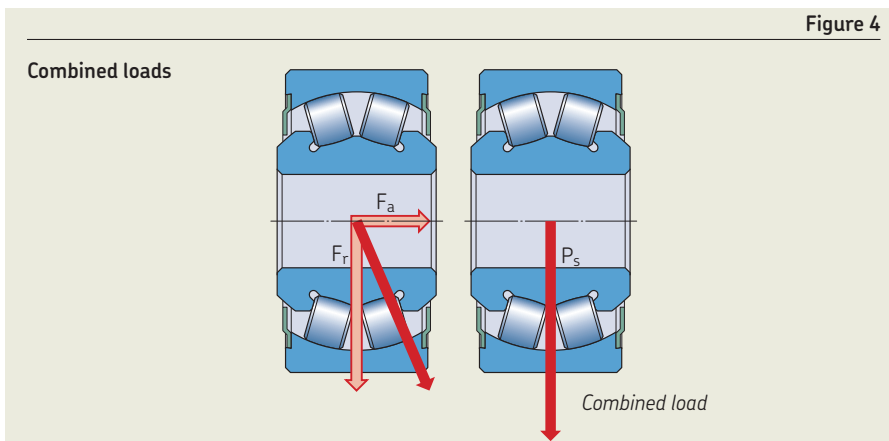

In cases where higher performance reliability is required, L_{10} is often used. The L_{10} life means that, for a given group of bearings, 90% are expected to achieve the duty cycle.

The relationship between L_{50} and L_{10} life is 5 to 1. For example, if the L_{50} life is 10 000 cycles under a given dynamic operating load fixed to a given ring and at a given oscillation angle, then the L_{10} life is 2 000 cycles.

Load-life relationship:

L Life in cycles

$$L = K \frac{45}{Y} \left(\frac{D.L.r}{P} \right)^{11/3}$$

K Reliability factor = 2 000 for L_{10}
= 10 000 for L_{50}

Y Oscillation angle [°]

D.L.r Dynamic Load rating [lbf/kN]

P Dynamic operating load or equivalent radial dynamic operating load [lbf/kN]

In the case of combined loads, the equivalent radial dynamic operating load is equal to:

$$P = F_r + Y F_a$$

Where

Y Axial load factor, depending on bearing type:

$$= \frac{C_s}{C_a} \text{ for ball bearings}$$

(Deep groove ball bearings, double row self-aligning ball bearings and deep groove ball bearings with self-aligning ring)

$$= 0 \text{ for single row spherical roller bearings}^1)$$

$$= 2,5 \text{ for double row spherical roller bearings}$$

P Equivalent radial dynamic operating load [lbf/kN]

F_r Radial component of the operating dynamic load [lbf/kN]

F_a Axial component of the operating dynamic load [lbf/kN]

Lubrication

Lubrication is used to:

- Reduce friction
- Reduce wear rate
- Extend bearing service life
- Protect against corrosion
- Block contaminants from entering the bearing

Greases used in SKF bearings are listed in **table 5**. At least 80% of the free space in the bearings is filled with grease. SKF standard bearings are lubricated for life and cannot be relubricated.

Lubrication is primarily chosen according to the operating temperature.

Contact SKF if the operating temperatures are outside the permissible range.

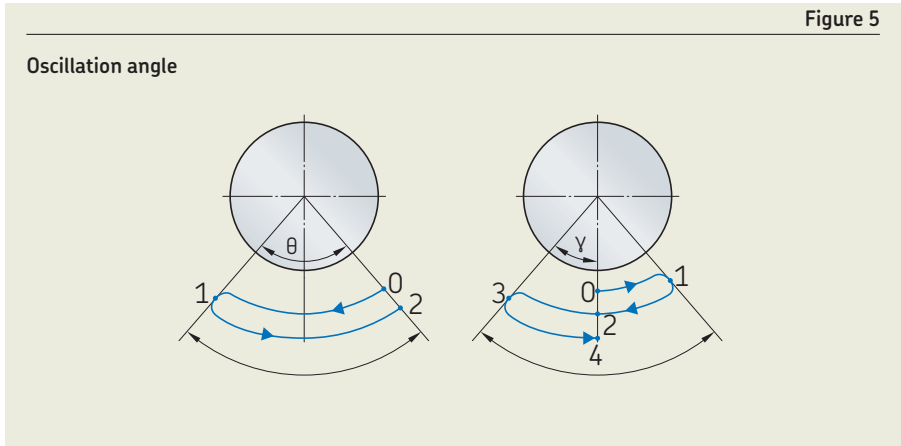

Figure 5

Standard greases		
NATO codes	Standard	Operating temperature
G354	MIL PRF 23827 type I	-73 to +121 °C (-100 to +250 °F)
G395	MIL PRF 81322	-54 to +177 °C (-64 to +350 °F)

1) Single row spherical roller bearings are designed to carry dynamic axial loads, F_a that are momentary or intermittent and do not exceed 30% of the operating dynamic radial load, F_r . Therefore, in case of combined load, the equivalent radial dynamic operating load to consider is equal to: $P = F_r$

Operating temperature

1

The permissible operating temperature of airframe rolling bearings is typically limited by the grease capability. Refer to *Lubrication page 39* for more information about grease temperature limits.

Sealing and shielding

SKF supplies standard bearings with two types of protection:

- Non-contacting shields
- Contact seals

Bearings with shields

Bearings with shields are used in environments with low levels of contamination and where there is little risk that water or steam for example can come in contact with the bearing.

The shield can be fixed in the outer ring by staking inside a groove or kept in place by a metal retainer (**figure 6**).

Bearings with seals

Bearings with seals are the preferred solution if:

- Contamination is moderate to heavy
- There is a risk of contact with moisture or water spray

The seals protect the bearing against water splashes but they cannot completely stop water from entering the bearing. A metal retainer is used to keep the seal in place in the bearing outer ring (**figure 6**).

The sealing solution can impact bearing torque. For more information, refer to *Friction and torque page 41*.

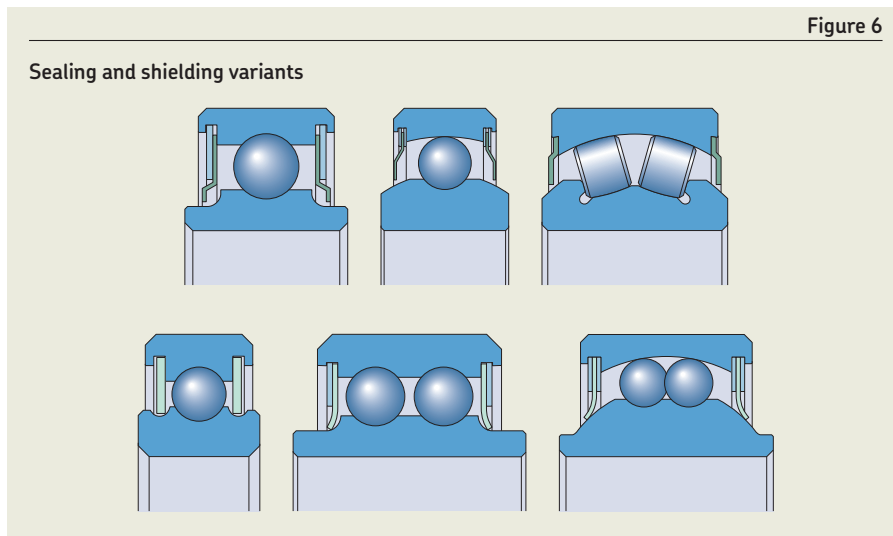

Friction and torque

Two types of frictional moments can be defined for a bearing, rotational frictional moment and swivelling frictional moment (figure 7).

The rotational frictional moment is mainly related to the rolling friction of the rolling elements on the raceways.

The swivelling frictional moment for bearings with swivelling capability is mainly related to the sliding friction of the bearing rolling elements on the raceway.

See figure 8.

Among other parameters, friction can be influenced by lubrication (refer to *Lubrication* page 39), bearing internal clearance (refer to *Bearing interfaces* page 42), bearing fits (refer to *Bearing fits* page 42), and sealing (refer to *Sealing and shielding* page 40 and *Seal friction* page 41).

Rotational frictional moment

The rotational frictional moment is not constant. The starting torque is higher than the bearing rolling frictional moment. This is due to the initial resistance to rotation that the bearing has to overcome before increasing the speed of the rolling elements (diagram 1).

For airframe rolling bearings, performing oscillation movements or a low number of complete rotations, the starting torque is a relevant design parameter.

Starting torque

The starting torque is defined as the maximum torque required to start the rotation of the outer ring with the inner ring held stationary. This torque is measured without load applied on the bearing. The maximum starting torque can be found in the relevant product tables. The starting torque of self-aligning bearings is independent of misalignment.

Seal friction

The starting torque is increased by the contact pressure between the seal and the inner ring of the bearing. The torque values listed in the relevant product tables include this effect.

Swivelling frictional moment

For self-aligning ball bearings, spherical roller bearings, and deep groove ball bearings with a self-aligning ring, swivelling creates sliding friction. The resulting swivelling frictional moment is higher than the rotational frictional moment.

Swivelling frictional moment values are listed in the relevant product tables.

1

Diagram 1

Rotational frictional moment

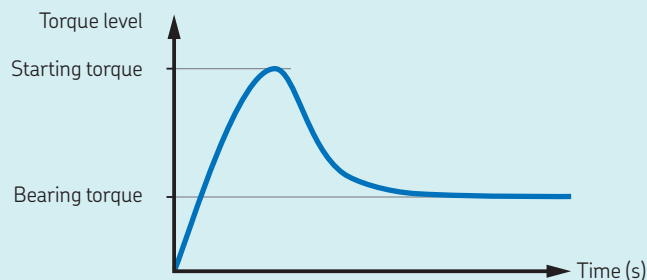

Figure 7

Bearing torque

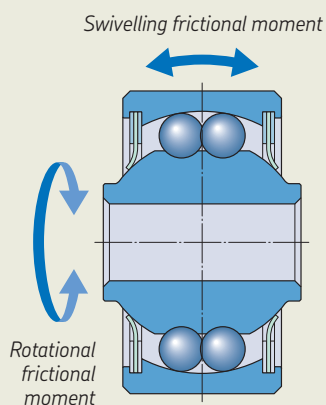
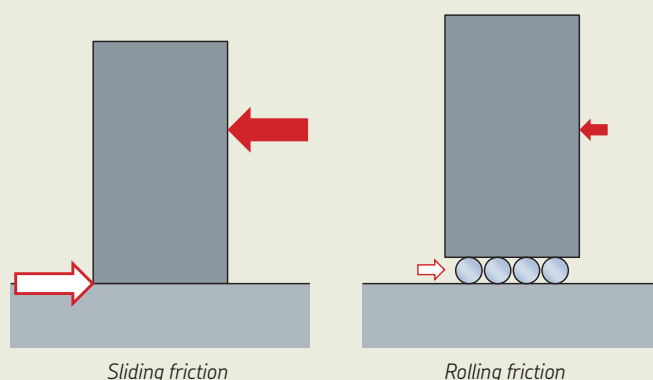

Figure 8

Bearing friction



Bearing interfaces

Selecting fits

1

For the bearing to function properly, its rings must be fully supported and mounted with an appropriate fit on the shaft and in the housing.

In general, airframe rolling bearings are mounted with a loose fit on the shaft and an interference fit in the housing but other housing fits can also be used depending on the application requirements. Refer to **table 8** for recommendations.

For deep groove ball bearings with self-aligning ring, refer to *Flanged units with positioning holes* **page 44** for fitting recommendations.

NOTE: The mounting fit can reduce the bearing radial internal clearance and increase the rotational frictional moment. Care must be taken to properly choose the right combination of fit and radial internal clearance to ensure proper function of the bearing. Refer to **table 8** for recommendations.

Clearance values are listed in the relevant product tables. For more information, refer to *Internal clearance* **page 47**.

In the case of interference fit by pairing, care must be taken to follow the specific housing tolerances for each bearing type, see **tables 6 and 7**.

Bearing fit can be impacted by differing coefficients of thermal expansion between the bearing and the housing and shaft materials. This effect must be considered in order to select the appropriate bearing mounting condition.

Axial location of bearing

When bearings are subjected to axial loads, it is not sufficient to use an interference fit alone to axially locate the bearing in a cylindrical housing bore. Common ways of locating bearing rings axially in a housing bore are by staking or using flanges.

Staking

To axially locate the bearing, the housing is generally staked onto the bearing's outer ring. Staking is a plastic deformation of the housing clamping the bearing. This axially locates the bearing, while not damaging the bearing ring, typically made of harder material than the housing.

This operation can be done either by point (also referred to as staking by ball) or by notch staking at multiple points around the circumference of the housing's bore diameter. See **figure 9**.

Figure 9. Staking

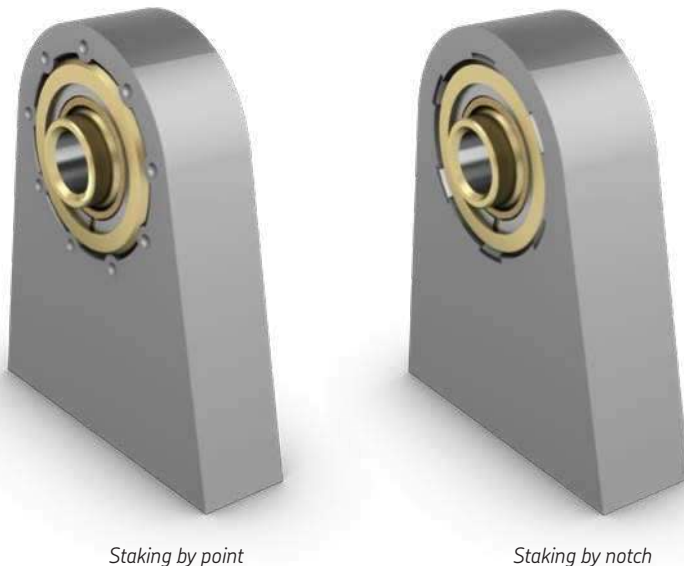

Table 6

Housing interference for deep groove ball bearings

D	>	≤	Light alloy housing		Steel housing	
			Light interference	Normal interference	Light interference	Normal interference
mm		μm				
16	24		4-8	8-12	2-6	5-9
24	32		8-12	12-16	4-8	8-12
32	48		10-14	14-18	6-10	10-14
48	78		12-16	16-20	7-11	11-15
78			14-18	18-22	9-13	13-17

Table 7

Housing interference for self-aligning ball bearings and spherical roller bearings

D	>	≤	Light alloy housing		Steel housing	
			Light interference	Normal interference	Light interference	Normal interference
mm		μm				
16	24		2-6	5-9	1-5	3-7
24	32		4-8	8-12	2-6	5-9
32	48		6-10	10-14	3-7	6-10
48			7-11	11-15	5-9	8-12

Table 8

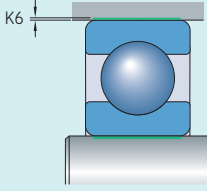
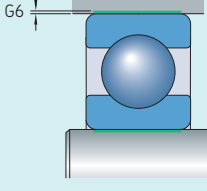
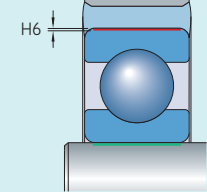
Mounting conditions	Recommended bearing clearance		Comments	
	Metric	Inch		
Interference fit by pairing (matching)	Table 6 for deep groove ball bearings Table 7 for self-aligning ball bearings and spherical roller bearings	Increased clearance	Standard clearance	Internal clearance reduction accurately managed
Transition fit		Standard clearance	Reduced clearance	Low to moderate internal clearance reduction
Loose fit with adhesive bonding		Reduced clearance	Reduced clearance	No impact on internal clearance
Mounting in staked bush		All bearings	All bearings	Moderate internal clearance reduction

Flanged units with positioning holes

The flanged units (such as deep groove ball bearings with self-aligning ring) incorporate deep groove ball bearings with a spherically shaped outside diameter integrated into a flanged housing featuring positioning holes, see **figure 11**. This assembly facilitates the mounting by allowing for the bearing to be located by bolting the flange positioning holes directly onto the aircraft structure.

If the bearing is oriented inside the housing, it should be mounted with a loose fit, see **Figure 10**.

For mounting into a particular application, SKF can provide support to design a suitable flange shape.

Flanged bearing

A flanged outer ring is a good solution to locate the bearing axially in one direction, see **figure 12**. The aircraft system must also provide a locating solution in order to retain the bearing when subjected to an axial load in the direction not retained by the flange.

The standard KNRCE series uses this design.

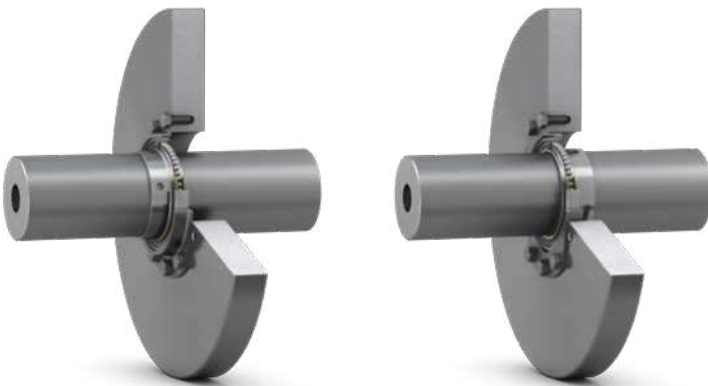

Figure 10

Locating flanged units with positioning holes

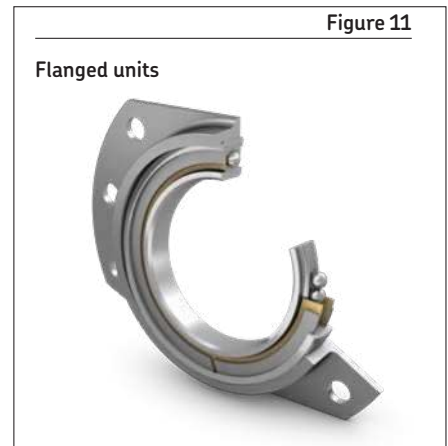
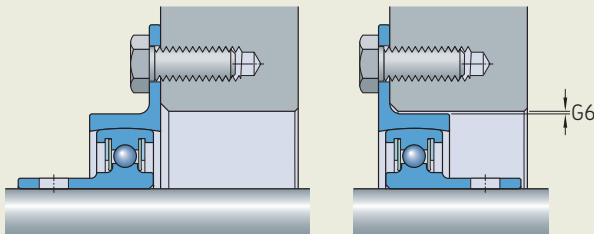

Figure 11

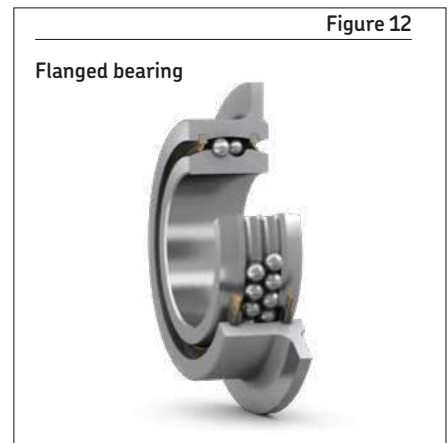

Figure 12

Bearing data

Dimensions and tolerances

Relevant interface dimensions and tolerances are listed in the product tables.

Where

Δd_{mp} = Single plane mean bore diameter deviation

ΔD_{mp} = Single plane mean outside diameter deviation

Figure 13, top figure shows the measurement definition for a single plane mean diameter deviation.

And

Δd_s = Deviation of a single outside bore diameter

ΔD_s = Deviation of a single outside diameter

Figure 13, bottom figure shows the measurement definition for the deviation of a single diameter.

Relevant geometrical tolerances are listed in the product tables.

Where

K_{ia} = Radial run-out of assembled bearing inner ring

K_{ea} = Radial run-out of assembled bearing outer ring

S_{ia} = Inner ring side run-out with raceway

S_{ea} = Outer ring side run-out with raceway

Figure 14 shows the measurement definition for the bearing run-outs.

For more information, refer to ISO 1132 (Rolling bearings - tolerances).

Material

Bearing rings and rolling elements

For the material of bearing rings and rolling elements, the main selection criteria are corrosion resistance and material hardness.

Table 9 gives the different designations, reference standards and key characteristics of bearing steels used for SKF rolling bearings.

In addition to **Table 9** SKF can propose a wide variety of materials to meet specific application requirements. For more information, refer to *Customized products page 51*.

Airframe rolling bearings can use SKF Aerospace precision specialty balls. As a leading manufacturer of precision specialty balls, SKF provides:

- A wide range of dimensions, with diameters from 0,7 to 64 mm (0.027 to 2.52 inch)
- A wide range of tolerances from ABMA¹⁾ or ISO grade 3 to 48
- A wide range of materials, typically the same material as rings is used (refer to **table 9** for *standard materials*, and *Customized products page 51* for specific materials).

¹⁾ ABMA is American Bearing Manufacturers Association standards

Figure 13

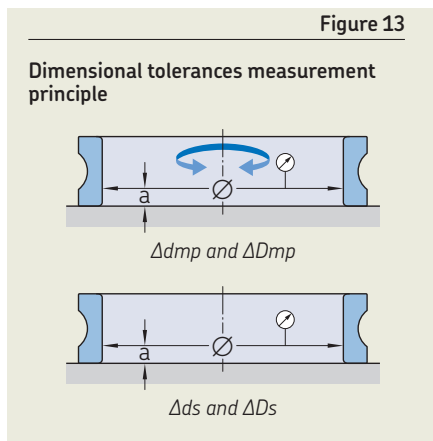
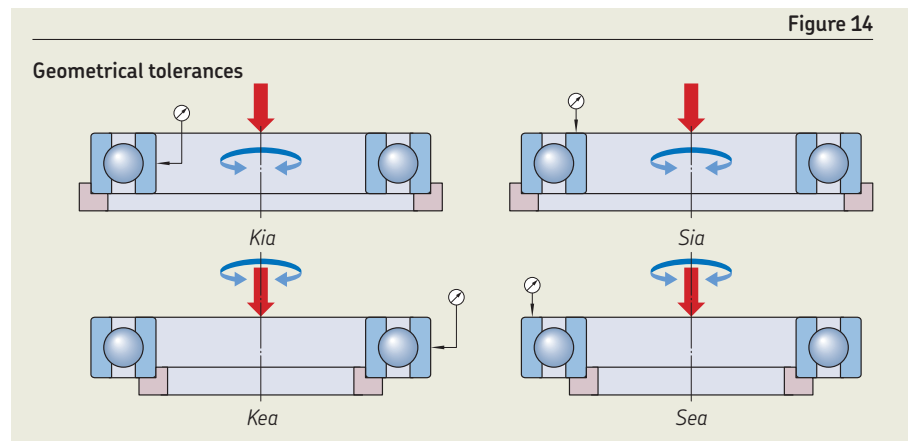

Figure 14



Flange of deep groove ball bearings with self-aligning ring

The flange of deep groove ball bearings with self-aligning ring has a spherical contact with the bearing outer ring and is not exposed to rolling element contact pressure. Materials similar to those for spherical plain bearings are typically selected for the flange. Refer to *Spherical plain bearings – Materials* **page 138** for more information. Standard materials are listed in **table 10**.

Surface treatments

In application, rolling bearings can be exposed to various environmental conditions including humidity, heat and fluids. These can limit the bearing life or performance by increasing the risk of contamination and corrosion.

Therefore, SKF provides surface treatments for increased general corrosion resistance and increased fretting resistance. Surface treatments are applied to ring surfaces, except on raceways, on the spherical surface of the flange of bearings with self-aligning ring and on the bore of the inner ring.

The standard treatment options are zinc-nickel or cadmium plating.

- Cadmium plating is applied according to AMS QQP416. It is carried out with or without a chromate treatment following the chosen standard. This treatment can include chromium 6 compounds and may be subject to environmental legislation.
- Zinc-nickel plating is a chromium 6 free alternative to cadmium plating, compliant to environmental legislation. Zinc-nickel is applied in accordance with AMS 2417.

Corrosion-resistant steel inner rings can also be passivated according to AMS 2700 or ISO 8075, as required per the relevant standards.

The bearing interface dimensions and tolerances from product tables are not modified when surface treatments are used.

SKF can supply other kinds of surface treatments for specific purposes. Refer to *Customized products* **page 51**.

Table 9

Standard materials for bearing rings and rolling elements

Steel type	Corrosion resistance	Hardness HRC	Material designation	EN standards	AMS standards	Equivalent designation
Bearing steel	Moderate	Metric bearings : 59 to 64 Inch bearings : 60 to 66	52100	EN 2031	AMS 6440 or AMS 6444	100Cr6 (100C6)
Corrosion-resistant steel	Good	≥ 58 ¹⁾	440C	EN 2030	AMS 5630 or AMS 5618	X105CrMo17 (Z100CD17)

¹⁾ For inner rings with fixing holes,
Hardness on the side with raceway ≥ 58 HRC
Hardness on the side with fixing holes 20 to 30 HRC

Table 10

Standard materials for flanges of deep groove ball bearings with self-aligning ring

Steel type	Corrosion resistance	Material designation	EN standards	AMS standards	Equivalent designation
Stainless steel	Very good	17-4PH H1150	EN 2539	AMS 5643	Z6CNU17.04 H1150
Bearing steel	Moderate	52100	EN 2031	AMS 6440 or AMS 6444	100Cr6 (100C6)
Corrosion-resistant steel	Good	431	EN 3490	AMS 5628	Z15CN17.03
Alloy steel	Moderate	15CDV6	EN 2249	N/A	-

Sealing and shielding

Seals

Seals used in SKF bearings are typically made of a PTFE compound with or without glass fibre reinforcement:

- Deep-groove ball bearings and deep groove ball bearings with self-aligning ring use a PTFE (Polytetrafluoroethylene) compound (**figure 15**).
- Self-aligning ball bearings and spherical roller bearings use a PTFE compound reinforced with glass fibres. This provides better resistance when swivelling (**figure 15**).

Shields

Depending on bearing series design the shielding can be made using a metallic shield (generally made of stainless steel or light alloy steel) or a non-metallic shield (generally made of the same material used for seals, see **figure 15**).

Metal retainers

Metal retainers for seals and shields are made of stainless steel.

Internal clearance

Bearing internal clearance is defined as the total distance through which one bearing ring can be moved in relation to the other under a defined measuring load according to the relevant standard (**figure 17**). It can be measured in the radial direction (radial internal clearance) or in the axial direction (axial internal clearance).

Diagonal internal clearance for double row deep groove ball bearings is defined as the misalignment that can be measured between the shaft and the outer ring. See **figure 16**.

Clearance values are listed in the relevant product tables.



Figure 15. Seal materials

Seal material using PTFE compound

Seal material using a PTFE compound reinforced with glass fibres

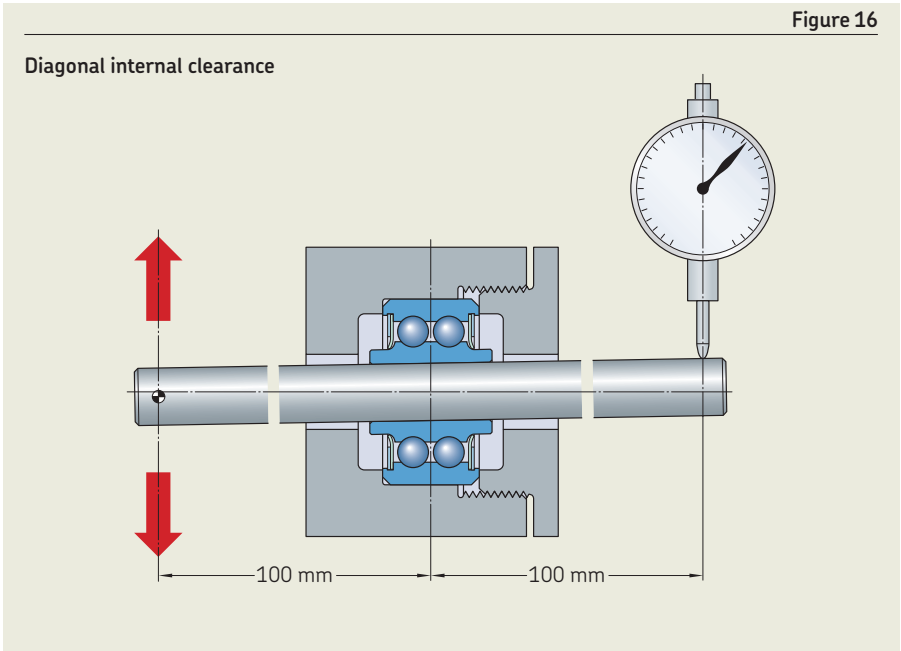

Figure 16

Diagonal internal clearance

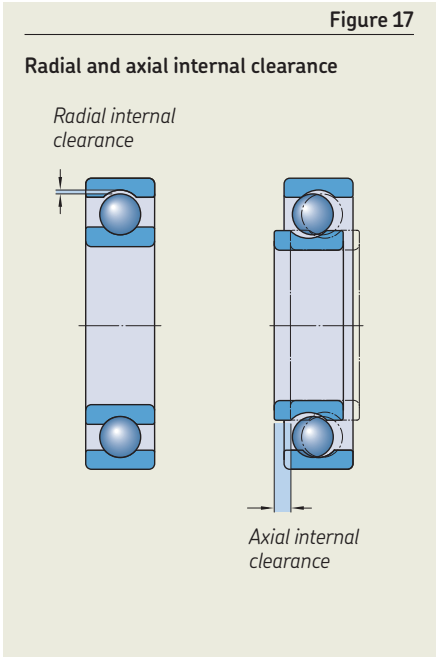

Figure 17

Radial and axial internal clearance

Radial internal clearance

Axial internal clearance

Increased internal clearance for metric bearings

The standard internal clearance of inch standard bearings is larger than the standard internal clearance of metric standard bearings. To attain values similar to inch size bearings, metric bearings with increased internal clearance can be used.

The values of increased internal clearance for metric bearings, are listed in the relevant product tables.

Precision bearings

Precision bearings offer reduced dimensional tolerances (bore, outside diameter and width) and geometrical tolerances (radial and axial run-out). The tolerances are listed in the relevant product tables.

As well as reduced dimensional and geometrical tolerances, the inch precision bearings have reduced radial clearances. For more information, refer to the relevant product tables.

Other clearances can be supplied, refer to *Customized products* **page 51**.

Operating clearance

In most applications, the initial internal clearance in a bearing is greater than its operating clearance. This is due to the effects of:

- **Mounting conditions:** For example, an interference fit with the housing can reduce the bearing internal clearance (**figure 18**)
- **Operating temperature conditions:** Thermal expansion of the bearing rings and associated components can lead to dimensional changes and impact the bearing internal clearance (**figure 19**)

These effects must be considered when selecting the initial internal clearance.

Bearings must have an appropriate operating clearance to operate correctly. Ball bearings require an operating clearance that is positive and close to zero. Roller bearings require some small operating clearance.

Figure 18

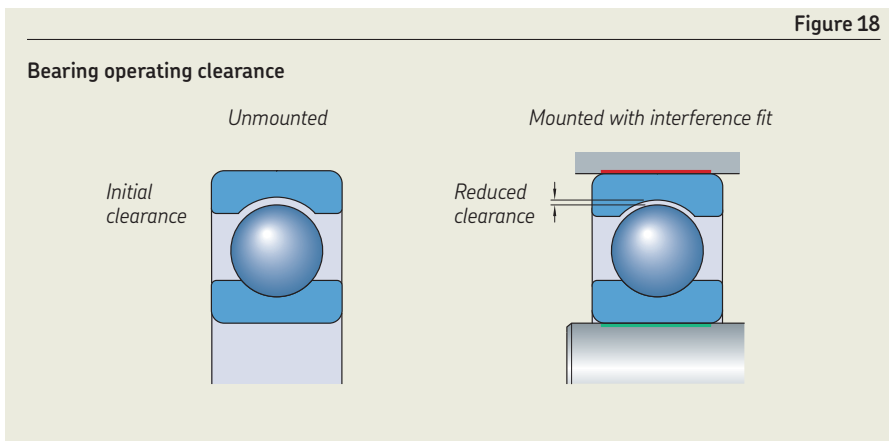
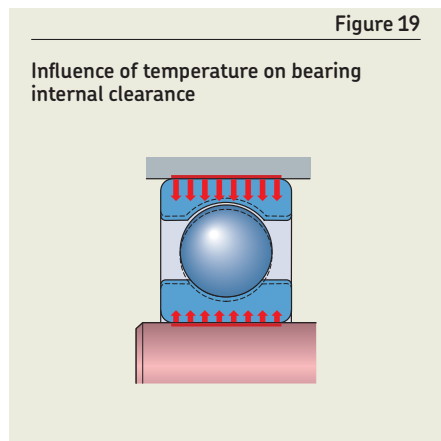

Figure 19



Bearing handling

Rolling bearings are reliable parts that can provide long service life, if handled and mounted properly. Proper mounting requires experience, accuracy, a clean bearing, housing and shaft, appropriate tools and a clean work environment.

The information provided in the following section is intended to indicate what must be considered to facilitate bearing mounting and dismounting.

NOTE: For the purpose of bearing replacement, SKF provides oversized bearings. For more information, refer to *Dismounting* page 50.

Mounting

The shaft and housing should be chamfered to facilitate bearing mounting. It is important that bearings do not receive direct shocks. The mounting force must never be applied through the rolling elements, but should be applied evenly distributed on the ring to prevent the bearing from tilting or skewing (**figure 21 and 22**).

A typical mounting tool is shown in **figure 20**. Refer to the SKF catalogue "Bearing fitting tool" for more details.

https://www.skf.com/binary/30-81444/13073EN_TMFseries.pdf

After mounting, a visual inspection should show no alteration of the bearing. The bearing should turn freely when rotated by hand and feel smooth, with no tight spots, as defined in the relevant technical standards.

Figure 21

Bearing mounting on shaft

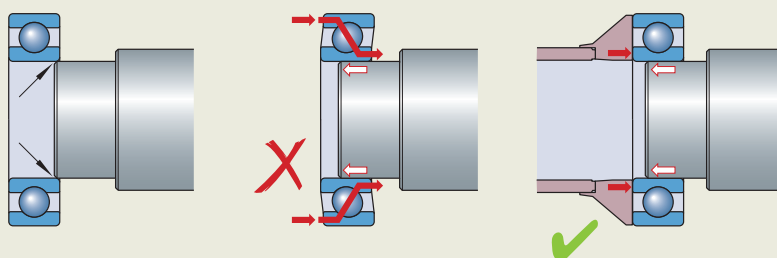

Figure 20

Mounting tool

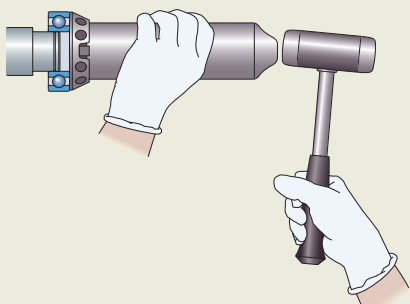
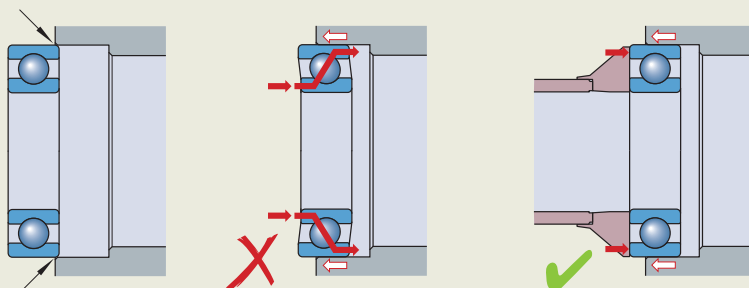

Figure 22

Bearing mounting in housing



Dismounting

1

Dismount rolling bearings by applying a force on the outer ring, or on the inner ring (after removal of the shaft which is typically mounted with clearance, refer to *Selecting fits* page 42).

A typical dismounting tool is shown in **figure 23**. Refer to the SKF bearing dismounting tool catalogue for more details. <https://www.skf.com/binary/21-163650/03000EN.pdf>

A dismounted bearing should not be reused. SKF supplies oversized bearings in a range of increments to allow for reuse of existing housings. See oversized options in the relevant product tables.

Storage

The performance of bearings, seals and lubricants can be impacted by the bearing storage conditions and time in inventory. SKF recommends a “first in, first out” inventory policy and that the bearings are stored under the storage conditions and storage time specified as follows.

Storage conditions

To maintain the integrity of the product during storage, SKF recommends the following basic storage practices:

- Store bearings flat, in a vibration-free, dry area with a cool, steady temperature between 15 °C and 35 °C (*between 54 °F and 95 °F*)
- Control and limit the relative humidity of the storage area between 50 and 70%
- Keep bearings in their original individual unopened and undamaged packaging until immediately prior to mounting in application to prevent the ingress of contaminants and corrosion

For storage outside these conditions, the given storage life is not guaranteed. Contact SKF for more information.

Storage time

The maximum recommended storage time for SKF standard bearings is five years (starting from the date indicated on SKF’s packaging).

Beyond this limit, the ageing of grease and degradation of grease properties can lead to a reduction of bearing performance.

Therefore, after five years of storage, the grease in the bearing must be replaced by SKF.

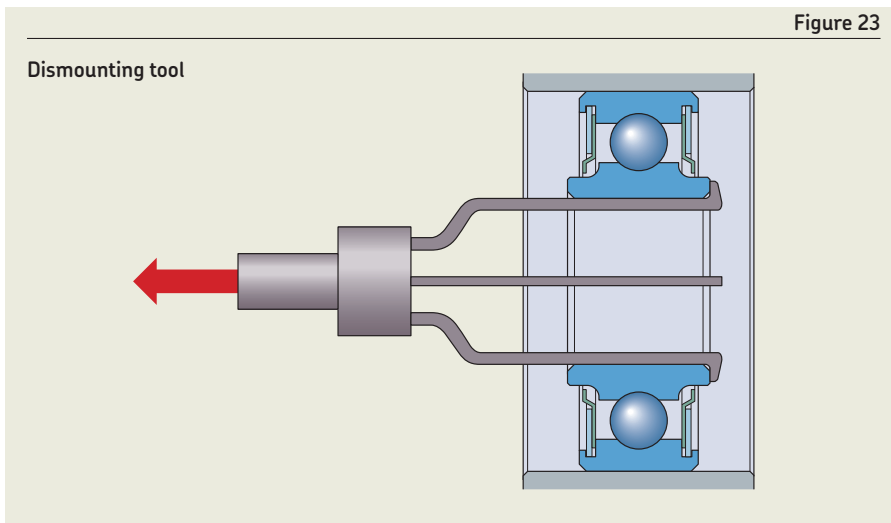

Customized products

Examples can include, but are not limited to:

- **Specific dimensions, clearances and geometries**
- **Materials**
 - Alternative steels,
 - Corrosion-resistant high nitrogen steel materials (CREN) for enhanced corrosion and mechanical resistance,
 - Case hardening steel materials with a soft core and hard surface, providing increased mechanical resistance.
 - M50 precision specialty ball materials for increased mechanical resistance, increased corrosion resistance, and/or use in high temperature application. M50-NiL materials can also be used for further increased mechanical resistance.
 - Ceramic balls and materials for high temperatures and/or when lubrication is not possible
- **Lubricants**
- **Surface treatments**

Including:

 - Nitriding
 - Silver plating
 - Chemical passivation
 - PVD







Certain treatments include chromium 6 compounds and may be subject to environmental legislation

Legacy standards

1

SKF can supply bearings compliant to the following legacy standards:

- EN 2009, EN 2010 and EN 2011
- EN 2012, EN 2013 and EN 2014
- EN 2015, EN 2016 and EN 2017
- EN 2018, EN 2019 and EN 2020

Function	Typical SKF solutions		
Mounting solutions	 <p><i>Flange, nut and washer</i></p>	 <p><i>Holed flange</i></p>	 <p><i>Staking groove on outer ring</i></p>
	<p><i>Mounted centred or not</i></p>		
	<p><i>Integrated axle</i></p>		
Space and weight saving			
Relubrication	 <p><i>Lubrication holes and grease nipple</i></p>	 <p><i>Lubrication grooves (in inner or outer ring)</i></p>	

Airframe rolling bearings with cage can be supplied and are typically used for pulley applications, including:

- JN..C and AP.. metric, EN 3182 and EN 3629
- JN..C, P..K, PD..K and AP.. inch, AS 21443

Refer to the *Engineered pulleys* in chapter 5.

1.1 Deep groove ball bearing single row (metric dimensions)

JN..

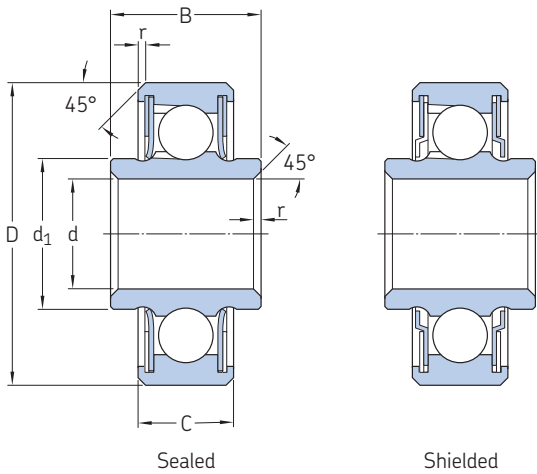

Technical specification	-
Product standard	-

Dimensions and tolerances

Nominal bore code	Dimensions			D	ΔD_{mp}	ΔD_s	C	B	d_1	r	Mass	Tolerances	
	d	Δd_{mp}	Δd_s									Kia max	Precision
-	mm	μm		mm	μm		mm				g	μm	
5	5	0/-8	+2/-10	16	0/-8	+2/-10	5	7	7,1	0,3/0,8	4	25	6
6	6	0/-8	+2/-10	19	0/-9	+2/-11	6	8	8,2	0,3/0,8	9	25	6
8	8	0/-8	+2/-10	22	0/-9	+2/-11	7	11	10,6	0,3/0,8	13	25	6
10	10	0/-8	+2/-10	26	0/-9	+2/-11	8	12	12,6	0,3/0,8	23	25	6
12	12	0/-8	+3/-11	28	0/-9	+3/-11	8	12	14,7	0,3/0,8	26	25	7
15	15	0/-8	+3/-11	32	0/-11	+3/-14	9	13	17,7	0,3/0,8	35	25	7
17	17	0/-8	+3/-11	35	0/-11	+3/-14	10	14	20,2	0,3/0,8	45	25	7
20	20	0/-10	+3/-13	42	0/-11	+3/-14	12	16	23,5	0,3/0,8	75	25	8
25	25	0/-10	+3/-13	47	0/-11	+3/-14	12	16	28,6	0,3/0,8	88	25	8
30	30	0/-10	+3/-13	55	0/-13	+4/-17	13	19	34,1	0,3/1	133	25	8

Tolerances cont., loads, clearance and torque

Nominal bore code	Tolerances				Static limit loads		Clearance		Maximum starting torque			
	Kea max	Precision	Sia max	Precision	Sea max	Precision	Standard	Increased	Shielded	Sealed		
-	μm		μm				Radial	Radial				
5	40	8	40	15	40	20	6,9	3,1	2/9	7/15	2	4
6	40	10	40	15	40	20	9,8	4,4	2/9	7/15	2,5	5
8	40	10	40	15	40	20	12	5,4	3/11	7/15	3	5
10	40	10	40	15	40	20	17,2	7,8	3/11	7/15	4	6
12	40	10	40	15	40	20	20,2	9,2	3/11	7/15	5	7
15	40	10	40	15	40	20	23,5	10,7	3/11	7/15	6	8
17	40	10	40	15	40	20	26,9	12,2	3/11	7/15	8	11
20	40	10	40	20	40	20	41,5	18,8	5/13	7/15	11	14
25	40	10	40	20	40	20	49	22,3	5/13	7/15	13	17
30	40	10	40	20	40	20	62,9	28,0	5/13	7/15	19	24



Designation system

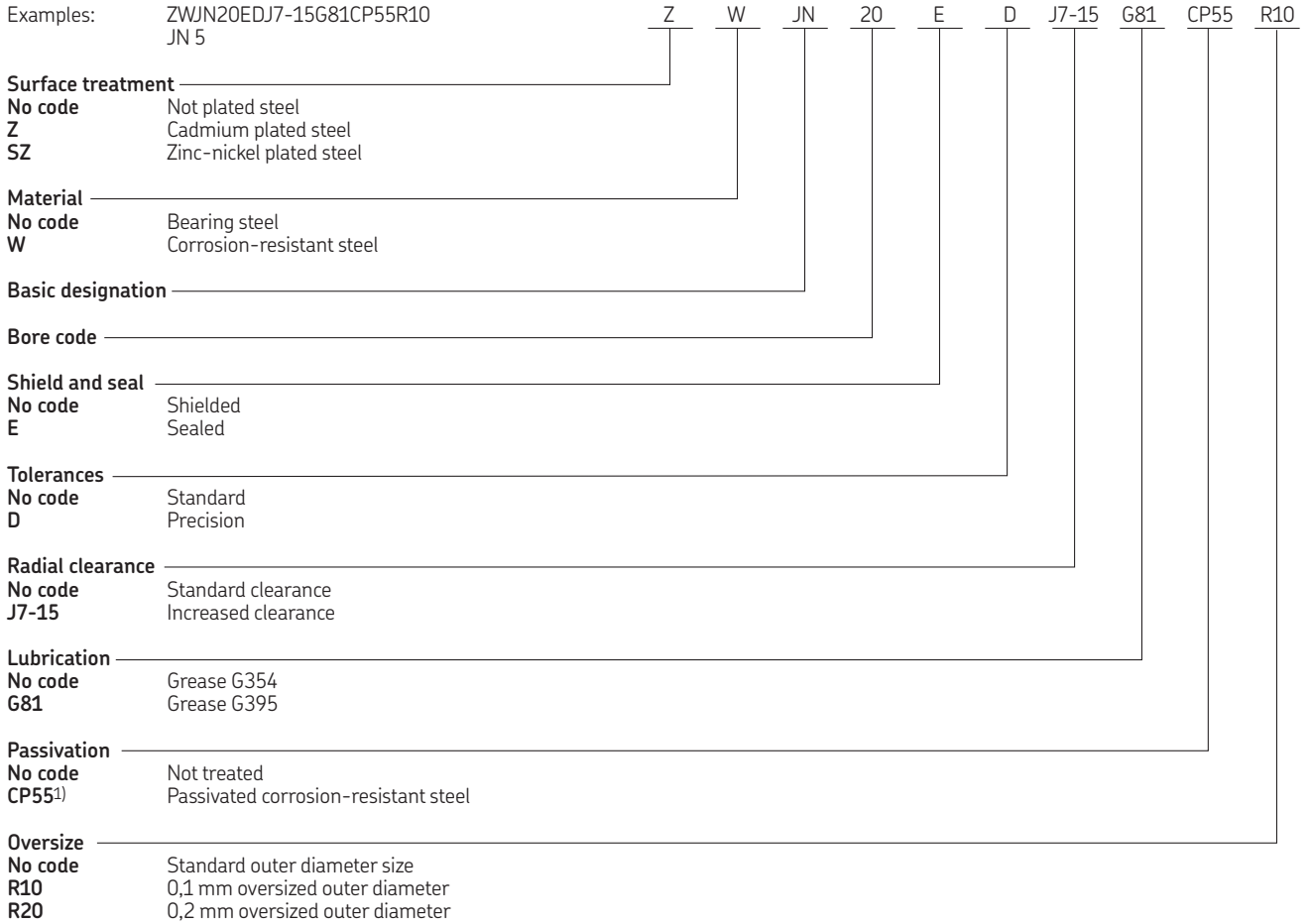

¹⁾ Available only for corrosion-resistant steel material without other surface treatment

1.2 Deep groove ball bearing single row (metric dimensions)

JNA..

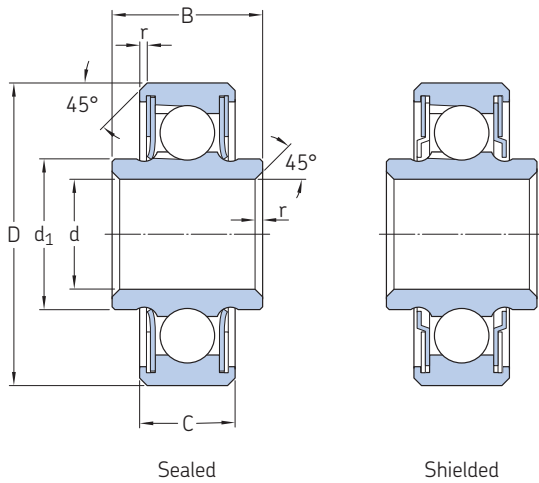

Technical specification EN 3280

Product standard

Standard tolerances and clearances:
 EN 3284 (Bearing steel)
 EN 3285 (Bearing steel cadmium plated)
 EN 3286 (Corrosion-resistant steel)

Precision tolerances and reduced clearances:

EN 3045 (Bearing steel)
 EN 3046 (Bearing steel cadmium plated)
 EN 3047 (Corrosion-resistant steel)

Dimensions and tolerances

Nominal bore code	Nominal Dimensions				D	Tolerances		C	B	d ₁	r	Mass	Tolerances				
	d	Δdmp	Δds	ΔDs		ΔDmp	ΔDs						Kia max	Kea max	Standard	Precision	Standard
–	mm	μm			mm	μm	mm	mm	mm	mm	mm	g	μm				
5	5	0/-8	+2/-10	16	0/-8	+2/-10	5	7	7,6	0,3/0,8	4	25	6	40	8		
6	6	0/-8	+2/-10	19	0/-9	+2/-11	6	8	8,6	0,3/0,8	9	25	6	40	8		
8	8	0/-8	+2/-10	22	0/-9	+2/-11	7	9	10,6	0,3/0,8	12	25	6	40	8		
10	10	0/-8	+2/-10	26	0/-9	+2/-11	8	10	12,6	0,3/0,8	21	25	6	40	8		
12	12	0/-8	+3/-11	28	0/-9	+3/-11	8	10	14,7	0,3/0,8	24	25	7	40	8		
15	15	0/-8	+3/-11	32	0/-11	+3/-14	9	11	17,7	0,3/0,8	32	25	7	40	10		
17	17	0/-8	+3/-11	35	0/-11	+3/-14	10	12	20,2	0,3/0,8	42	25	7	40	10		
20	20	0/-10	+3/-13	42	0/-11	+3/-14	12	14	23,5	0,3/0,8	72	25	8	40	10		
25	25	0/-10	+3/-13	47	0/-11	+3/-14	12	14	28,6	0,3/0,8	85	25	8	40	10		
30	30	0/-10	+3/-13	55	0/-13	+4/-17	13	15	34,1	0,3/1	123	25	8	40	10		

Tolerances cont., loads, clearance and torque

Nominal bore code	Tolerances				Static limit loads		Clearances				Maximum starting torque		
	Sia max	Sea max	Standard	Precision	Radial C _s	Axial C _a	Standard Radial	Axial max	Reduced Radial	Axial max	Increased Radial	Shielded	Sealed
–	μm				kN		μm					mNm	
5	40	15	40	20	6,9	3,1	2/13	100	2/9	80	7/15	2	4
6	40	15	40	20	9,8	4,4	2/13	100	2/9	80	7/15	2,5	5
8	40	15	40	20	12	5,4	2/13	100	2/9	80	7/15	3	6,5
10	40	15	40	20	17,2	7,8	2/13	100	2/9	80	7/15	4	7,5
12	40	15	40	20	20,2	9,2	3/18	120	3/11	100	7/15	5	8,5
15	40	15	40	20	23,5	10,7	3/18	120	3/11	100	7/15	6	10
17	40	15	40	20	26,9	12,2	3/18	120	3/11	100	7/15	8	12
20	40	20	40	20	41,5	18,8	5/20	120	5/13	120	7/15	10,5	15
25	40	20	40	20	49	22,3	5/20	120	5/13	120	7/15	13,5	18
30	40	20	40	20	62,9	28,6	5/20	150	5/13	120	7/15	19	25



Designation system

Examples:	ZWJNA20EDN744CP55R10	Z	W	JNA	20	E	DN744	CP55	R10
	JNA 5J7-15								
Surface treatment									
No code	Not plated steel								
Z	Cadmium plated steel								
SZ¹⁾	Zinc-nickel plated steel								
Material									
No code	Bearing steel								
W	Corrosion-resistant steel								
Basic designation									
Bore code									
Shield and seal									
No code	Shielded								
E	Sealed								
Variation									
	Tolerances	Lubricant	Clearances						
J7-15¹⁾	Standard	G354	Increased radial						
DJ7-15¹⁾	Precision	G354	Increased radial						
J7-15G81¹⁾	Standard	G395	Increased radial						
DJ7-15G81¹⁾	Precision	G395	Increased radial						
No code¹⁾	Standard	G354	Reduced radial and axial						
DN744	Precision	G354	Reduced radial and axial						
DN814	Precision	G395	Reduced radial and axial						
N813²⁾	Standard	G395	Standard radial and axial						
N743³⁾	Standard	G354	Standard radial and axial						
Passivation									
No code	Not treated								
CP55⁴⁾	Passivated corrosion-resistant steel								
Oversize									
No code	Standard outer diameter size								
R10¹⁾	0,1 mm oversized outer diameter								
R20¹⁾	0,2 mm oversized outer diameter								

1) SKF option

2) Replaces N811

3) Replaces N741

4) SKF option, available only for corrosion-resistant steel material without other surface treatment

1.3 Deep groove ball bearing single row (metric dimensions)

T..

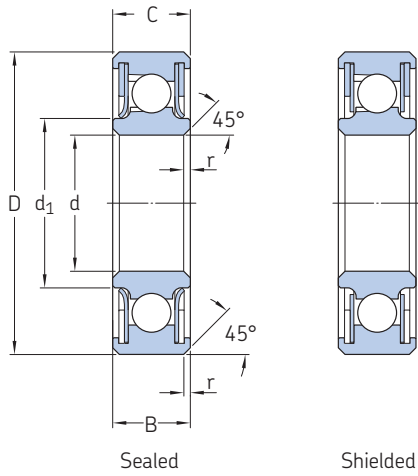

Technical specification -

Product standard -

1.3



Dimensions and tolerances

Nominal bore code	Dimensions		D	ΔD_{mp}	C	B	d_1	r	Mass	Tolerances	
	d	Δd_{mp}								Kia max Standard	Precision
-	mm	μm	mm	μm	mm				g	μm	
10	10	0/-8	22	0/-9	6	6	13	0,5	11	25	8
12	12	0/-8	24	0/-9	6	6	15	0,5	13	25	10
15	15	0/-8	28	0/-9	6	6	18,2	0,5	15	25	10
16	16	0/-8	30	0/-9	6	6	19,2	0,5	17	25	10
20	20	0/-10	35	0/-11	7	7	23,3	0,5	25	25	13
25	25	0/-10	40	0/-11	7	7	28,5	0,5	29	25	13
28	28	0/-10	43	0/-11	7	7	31,5	0,5	32	25	13
32	32	0/-11	48	0/-11	7	7	35,3	0,5	39	25	15
35	35	0/-12	51	0/-11	7	7	38,3	0,5	42	25	15
40	40	0/-12	57	0/-13	8	8	44,5	0,5	56	25	15
45	45	0/-12	62	0/-13	8	8	49,5	0,5	60	25	15
50	50	0/-12	68	0/-13	8	8	54,7	0,5	67	25	15
55	55	0/-15	73	0/-15	8	8	59,7	0,5	76	25	20
63	63	0/-15	82	0/-15	9	9	67,2	0,5	110	25	20
80	80	0/-17	100	0/-17	9	9	84,4	0,5	132	25	20
90	90	0/-17	115	0/-17	9	9	96,9	0,5	223	25	20



Designation system

Examples:	ZWAT20EDJ12-18G81CP55R10	Z	WA	T	20	E	D	J12-18	G81	CP55	R10
	T40										
Surface treatment											
No code	Not plated steel										
Z	Cadmium plated steel										
SZ	Zinc-nickel plated steel										
Material											
No code	Bearing steel										
WA	Corrosion-resistant steel										
Basic designation											
Bore code											
Shield and seal											
No code	Shielded										
E	Sealed										
Tolerances											
No code	Standard										
D	Precision										
Radial clearance											
No code	Standard clearance										
J12-18	Increased clearance										
Lubrication											
No code	Grease G354										
G81	Grease G395										
Passivation											
No code	Not treated										
CP55¹⁾	Passivated corrosion-resistant steel										
Oversize											
No code	Standard outer diameter size										
R10	0,1 mm oversized outer diameter										
R20	0,2 mm oversized outer diameter										

1) Available only for corrosion-resistant steel material without other surface treatment

Tolerances cont., loads, clearance and torque

Nominal bore code	Tolerances						Static limit loads		Clearance		Maximum starting torque	
	Kea max Standard	Precision	Sia max Standard	Precision	Sea max Standard	Precision	Radial C _s	Axial C _a	Standard Radial	Increased Radial	Shielded	Sealed
–	μm						kN		μm		mNm	
10	40	13	40	15	40	20	10,8	4,9	2/7	12/18	4	7
12	40	13	40	15	40	20	12,3	5,6	2/7	12/18	4	7
15	40	13	40	15	40	20	14,5	6,5	3/11	12/18	4	7
16	40	13	40	15	40	20	15,2	6,8	3/11	12/18	5	8
20	40	15	40	20	40	20	18,6	8,3	5/13	12/18	6	9
25	40	15	40	20	40	20	22,2	9,9	5/13	12/18	8	14
28	40	15	40	20	40	20	24,2	10,8	5/13	12/18	11	16
32	40	15	40	20	40	20	27	12,1	5/13	12/18	14	20
35	40	20	40	20	40	20	29	13,0	5/13	12/18	18	23
40	40	20	40	20	40	20	33,2	14,9	5/13	12/18	22	29
45	40	20	40	20	40	20	36,7	16,4	5/13	12/18	26	35
50	40	20	40	20	40	20	40,2	17,9	5/13	12/18	32	45
55	40	20	40	20	40	20	43,6	19,5	5/13	12/18	39	60
63	40	20	40	20	40	20	61,7	27,5	5/13	12/18	55	75
80	40	20	40	20	40	20	75,7	33,8	5/13	12/18	75	120
90	40	20	40	20	40	20	86,5	38,6	5/13	12/18	110	160

1.4 Deep groove ball bearing single row (metric dimensions)

TA..

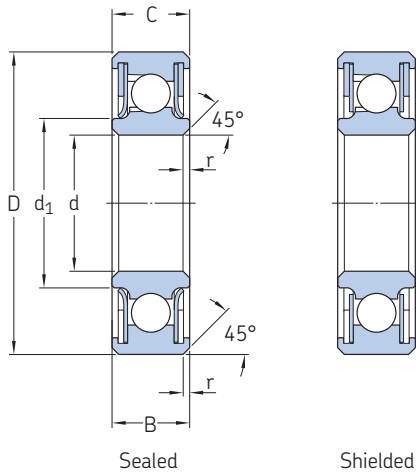

Technical specification EN 3280

Product standard

Standard clearances: EN 3281 (Bearing steel)
EN 3282 (Bearing steel cadmium plated)
EN 3283 (Corrosion-resistant steel)
Reduced clearances: EN 4033 (Corrosion-resistant steel)

Dimensions and tolerances

Nominal bore code	Dimensions		D	ΔD_{mp}	C	B	d_1	r	Mass	Tolerances			
	d	Δd_{mp}								Kia max Standard	Kia max Precision	Kea max Standard	Kea max Precision
–	mm	μm	mm	μm	mm	mm	\approx	g	μm				
10	10	0/-8	22	0/-9	6	6	13	0,5	11	25	8	40	13
12	12	0/-8	24	0/-9	6	6	15	0,5	13	25	10	40	13
15	15	0/-8	28	0/-9	7	7	17,6	0,5	16	25	10	40	13
17	17	0/-8	30	0/-9	7	7	19,6	0,5	18	25	10	40	13
20	20	0/-10	32	0/-11	7	7	23	0,5	20	25	13	40	15
25	25	0/-10	37	0/-11	7	7	28,1	0,5	23	25	13	40	15
30	30	0/-10	42	0/-11	7	7	33,1	0,5	26	25	13	40	15
35	35	0/-12	47	0/-11	7	7	38,3	0,5	30	25	15	40	15
40	40	0/-12	52	0/-13	7	7	43,3	0,5	38	25	15	40	20
50	50	0/-12	65	0/-13	7	7	53	0,5	55	25	15	40	20
60	60	0/-15	78	0/-13	10	10	63,5	0,5	100	25	20	40	20

Tolerances cont., loads, clearance and torque

Nominal bore code	Tolerances		Sea max		Static limit loads		Clearances		Reduced Radial	Axial max	Increased Radial	Maximum starting torque	
	Sia max Standard	Precision	Standard	Precision	Radial C_s	Axial C_a	Standard Radial	Axial max				Shielded	Sealed
–	μm				kN		μm					mNm	
10	40	15	40	20	10,8	4,9	2/13	100	2/7	100	12/18	4,5	12
12	40	15	40	20	12,3	5,6	3/18	100	2/7	100	12/18	5	13
15	40	15	40	20	16,3	7,4	3/18	100	2/7	100	12/18	5,5	14
17	40	15	40	20	17,7	8,0	3/18	100	2/7	100	12/18	6	15
20	40	20	40	20	17,4	7,9	5/20	100	2/9	100	12/18	6,5	16
25	40	20	40	20	21,5	9,8	5/20	100	2/9	100	12/18	8,5	18
30	40	20	40	20	24,7	11,1	5/20	100	2/9	100	12/18	14	20
35	40	20	40	20	28,6	12,9	6/20	100	2/9	100	12/18	18	23
40	40	20	40	20	32	14,5	6/20	100	2/9	100	12/18	22	29
50	40	20	40	20	43,1	19,6	6/23	120	2/9	120	12/18	32	47
60	40	20	40	20	70	31,8	8/28	150	2/9	150	12/18	55	77



Designation system

Examples:	ZWATA20EDN743CP55R10	Z	WA	TA	20	E	D	N743	CP55	R10
Surface treatment										
No code	Not plated steel									
Z	Cadmium plated steel									
SZ¹⁾	Zinc-nickel plated steel									
Material										
No code	Bearing steel									
WA	Corrosion-resistant steel									
Basic designation										
Bore code										
Shield and seal										
No code	Shielded									
E	Sealed									
Tolerances										
No code	Standard									
D¹⁾	Precision									
Variation										
	Lubricant									
J12-18¹⁾	G354									
J12-18G81¹⁾	G395									
N745²⁾	G354									
N815	G395									
N813³⁾	G395									
N743⁴⁾	G354									
	Clearances									
	Increased radial									
	Increased radial									
	Reduced radial and axial									
	Reduced radial and axial									
	Standard radial and axial									
	Standard radial and axial									
Passivation										
No code	Not treated									
CP55⁵⁾	Passivated corrosion-resistant steel									
Oversize										
No code	Standard outer diameter size									
R10¹⁾	0,1 mm oversized outer diameter									
R20¹⁾	0,2 mm oversized outer diameter									

1) SKF option

2) Replaces no code

3) Replaces N811

4) Replaces N741

5) Available only for corrosion-resistant steel material without other surface treatment

1.5 Deep groove ball bearing double row (metric dimensions)

AG..

Technical specification	-
Product standard	-

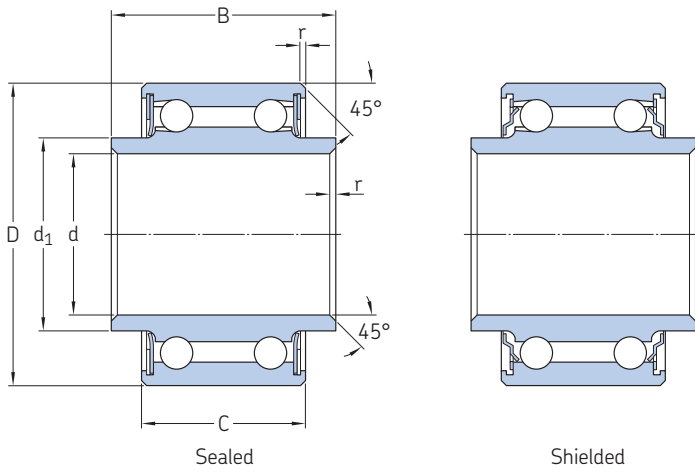

Dimensions and tolerances

Nominal bore code	Dimensions						C 0 -0,12	B 0 -0,12	d ₁ ≈	r +0,3 -0,2	Mass ≈ g	Tolerances	
	d	Δdmp (J7)	Δds	D	ΔDmp	ΔDs						Kia max Standard	Precision
-	mm	μm		mm	μm	mm					μm		
6	6	+8/-7	+2/-10	19	0/-8	+2/-11	12	17	8,6	0,5	22	25	6
8	8	+8/-7	+2/-10	22	0/-8	+2/-11	17	23	11,1	0,5	32	25	6
10	10	+8/-7	+2/-10	24	0/-8	+2/-11	17	23	13,1	0,5	42	25	6
12	12	+10/-8	+3/-11	26	0/-9	+2/-11	17	23	15,3	0,5	46	25	7
16	16	+10/-8	+3/-11	30	0/-9	+2/-11	17	23	19,1	0,5	57	25	7

Tolerances cont., loads, clearance and torque

Nominal bore code	Tolerances				Static limit loads		Diagonal clearance	Increased radial clearance	Maximum starting torque			
	Kea max Standard	Precision	Sia max Standard	Precision	Sea max Standard	Precision			Radial C _s	Axial C _a	Shielded	Sealed
-	μm				kN		μm		mNm			
6	40	10	40	15	40	20	16,6	7,4	50/250	7/15	3	5
8	40	10	40	15	40	20	20,8	9,3	50/250	7/15	4	6
10	40	10	40	15	40	20	24	10,6	50/250	7/15	6	9
12	40	10	40	15	40	20	26,3	11,8	50/250	7/15	7	11
16	40	10	40	15	40	20	31,8	14,2	50/250	7/15	9	14



Designation system

Examples:	ZWAG10EDJ7-15G81CP55R10	Z	W	AG	10	E	D	J7-15	G81	CP55	R10
Surface treatment											
No code	Not plated steel										
Z	Cadmium plated steel										
SZ	Zinc-nickel plated steel										
Material											
No code	Bearing steel										
W	Corrosion-resistant steel										
Basic designation											
Bore code											
Shield and seal											
No code	Shielded										
E	Sealed										
Tolerances											
No code	Standard										
D	Precision										
Clearances											
No code	Diagonal clearance										
J7-15	Increased radial clearance										
Lubrication											
No code	Grease G354										
G81	Grease G395										
Passivation											
No code	Not treated										
CP55¹⁾	Passivated corrosion-resistant steel										
Oversize											
No code	Standard outer diameter size										
R10	0,1 mm oversized outer diameter										
R20	0,2 mm oversized outer diameter										

¹⁾ SKF option, available only for corrosion-resistant steel material without other surface treatment

1.6 Deep groove ball bearing double row (metric dimensions)

AGN..

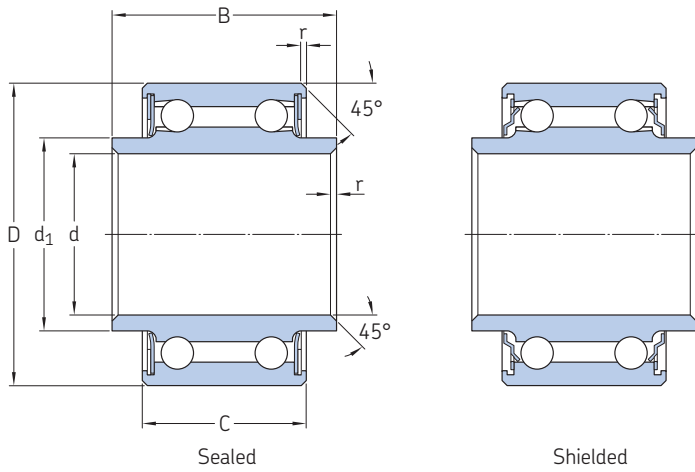

Technical specification	EN 3280
Product standard	EN 3056 (Bearing steel) EN 3057 (Bearing steel cadmium plated) EN 3058 (Corrosion-resistant steel)

Dimensions and tolerances

Nominal bore code	Dimensions						C	B	d ₁	r	Mass ≈	Tolerances	
	d	Δdmp (J7)	Δds	D	ΔDmp	ΔDs						Kia max Standard	Precision
–	mm	μm		mm	μm	mm					g	μm	
8	8	+8/-7	+2/-10	22	0/-8	+2/-11	17	22	10,6	0,5	30	25	6
10	10	+8/-7	+2/-10	26	0/-8	+2/-11	18	24	12,6	0,5	52	25	6
12	12	+10/-8	+3/-11	28	0/-8	+2/-11	18	24	14,7	0,5	60	25	7
15	15	+10/-8	+3/-11	32	0/-9	+3/-14	20	26	17,7	0,5	80	25	7
17	17	+10/-8	+3/-11	35	0/-9	+3/-14	22	28	20,2	0,5	100	25	7
20	20	+12/-9	+3/-13	42	0/-9	+3/-14	26	32	23,5	0,5	165	25	8

Tolerances cont., loads, clearance and torque

Nominal bore code	Tolerances				Static limit loads		Diagonal clearance	Increased radial clearance	Maximum starting torque			
	Kea max Standard	Precision	Sia max Standard	Precision	Sea max Standard	Precision			Radial C _s	Axial C _a	Shielded	Sealed
–	μm				kN		μm		mNm			
8	40	10	40	15	40	20	24	10,9	50/250	7/15	4	6
10	40	10	40	15	40	20	34,4	15,6	50/250	7/15	6	9
12	40	10	40	15	40	20	40,4	18,4	50/250	7/15	7	11
15	40	10	40	15	40	20	47	21,4	50/250	7/15	9	14
17	40	10	40	15	40	20	53,8	24,5	50/250	7/15	11	17
20	40	10	40	20	40	20	83	37,7	50/250	7/15	15	23



Designation system

Examples:	ZWAGN20EDJ7-15G81CP55R10	Z	W	AGN	20	E	D	J7-15	G81	CP55	R10
	AGN 8										
Surface treatment											
No code	Not plated steel										
Z	Cadmium plated steel										
SZ¹⁾	Zinc-nickel plated steel										
Material											
No code	Bearing steel										
W	Corrosion-resistant steel										
Basic designation											
Bore code											
Shield and seal											
No code	Shielded										
E	Sealed										
Tolerances											
No code	Standard										
D¹⁾	Precision										
Clearances											
No code	Diagonal clearance										
J7-15¹⁾	Increased radial clearance										
Lubrication											
No code	Grease G354										
G81	Grease G395										
Passivation											
No code	Not treated										
CP55²⁾	Passivated corrosion-resistant steel										
Oversize											
No code	Standard outer diameter size										
R10¹⁾	0,1 mm oversized outer diameter										
R20¹⁾	0,2 mm oversized outer diameter										

1) SKF option

2) SKF option, available only for corrosion-resistant steel material without other surface treatment

1.7 Deep groove ball bearing with self-aligning ring single row (metric dimensions)

TRCE..

Technical specification

EN 3727

Product standard

EN 3059 (bearing steel bearing and cadmium plated steel ring)
EN 3060 (bearing steel cadmium plated bearing and cadmium plated steel ring)
EN 3061 (Corrosion-resistant steel bearing and ring)



Dimensions

Nominal bore code	Dimensions		Δdmp For products per EN standard	Δds For other products	D ±0,2	C For products per EN standard 0/-0,12	For other products 0/-0,1	B ±0.15	D ₁ ±0.05	A	r ₁ +0,3 -0,2	E For products per EN standard ± 1	For other products
	d	Δdmp											
–	mm	μm	mm										
16	16	0/-8	0/-8	+3/-11	58	6	6	8	33	47	0,5	36	35
20	20	0/-10	0/-10	+3/-13	63	7	7	9	38	52	0,5	42	42
25	25	0/-10	0/-10	+3/-13	68	7	7	9	43	57	0,5	46	46
32	32	0/-12	0/-11	+3/-15	77	7	7	9	52	66	0,5	55	55
35	35	0/-12	0/-12	+3/-15	80	7	7	9	55	69	0,5	58	58
40	40	0/-12	0/-12	+3/-15	86	8	8	10	61	75	0,5	64	64
45	45	0/-12	0/-12	+3/-15	91	8	8	10	66	80	0,5	68	68
50	50	0/-12	0/-12	+3/-15	97	8	8	10	72	86	0,5	74	74
63	63	0/-15	0/-15	+4/-19	111	9	9	11	86	100	0,5	90	90

Dimensions, loads and clearance

Nominal bore code	Dimensions		Mass Standard circular profile =	C optional profile	Static limit load Radial C _s	Clearances		Axial max between outer and inner rings	
	α	β For products per EN standard ± 1°				Radial Bearing in corrosion-resistant steel per EN standard	For other bearings in bearing steel or in corrosion-resistant steel		
–	°		g		kN	μm			
16	4	0	0	47	38	15,2	2/7	3/11	120
20	3,5	14	14	62	50	18,7	2/7	5/13	120
25	3	14	14	70	58	20,6	2/7	5/13	120
32	2,5	24	24	94	78	24,5	2/7	5/13	120
35	2,3	24	30	100	86	25,5	2/9	5/13	120
40	2	30	30	125	104	29,5	2/9	5/13	120
45	2	30	30	137	114	32,4	2/9	5/13	120
50	1,7	30	30	155	129	35,3	2/9	5/13	120
63	1,5	44	44	210	178	39,2	2/9	5/13	120





Designation system

Examples:	XTRCE20TCDN741CP55R10		X	TRCE	20	T	C	D	N741	CP55	R10
	SWATRCE16E										
Prefix code	Material and surface treatment		Self-aligning ring								
No code	Ball bearing		Cadmium plated steel								
Z	Bearing steel		Cadmium plated								
S¹⁾	Bearing steel		-								
SZ¹⁾	Bearing steel		Zinc-nickel plated								
WA¹⁾	Corrosion-resistant steel		-								
SWA¹⁾	Corrosion-resistant steel		-								
X	Corrosion-resistant steel		-								
Basic designation											
Bore code											
Shield and seal											
T	Shielded										
E	Sealed										
Flange profile											
No code	Standard circular profile										
C	Optional profile										
Tolerances											
No code	Standard										
D¹⁾	Precision										
Variation											
No code¹⁾	Lubricant		Swivelling torque								
N741	G354		Standard								
N811	G354		Reduced								
	G395		Reduced								
Passivation											
No code	Not treated										
CP55²⁾	Passivated corrosion-resistant steel										
Oversize											
No code	Standard outer diameter size										
R10	0,1 mm oversized outer diameter ¹⁾										
R20	0,2 mm oversized outer diameter ¹⁾										

¹⁾ SKF option

²⁾ Available only for corrosion-resistant steel material without other surface treatment

Torque and tolerances

Nominal bore code	Maximum starting torque		Swivelling torque		Tolerances							
	Shielded	Sealed	Standard	Reduced	Kia max	Kea max		Sia max		Sea max		
					Standard	Precision	Standard	Precision	Standard	Precision	Standard	Precision
	mNm		Nm		µm							
16	8	12	2/7	0,8/3	25	7	40	10	40	15	40	20
20	9	14	3/8	0,8/3	25	8	40	10	40	20	40	20
25	12	21	4/9	0,8/3	25	8	40	10	40	20	40	20
32	21	30	5/10	1/4	25	10	40	10	40	20	40	20
35	27	35	5/11	1/4	25	10	40	10	40	20	40	20
40	33	44	8/14	1,3/4,5	25	10	40	10	40	20	40	20
45	39	53	9/15	1,3/4,5	25	10	40	10	40	20	40	20
50	48	68	9/18	1,5/5	25	10	40	10	40	20	40	20
63	83	113	10/20	2/6	25	10	40	10	40	20	40	20

1.8 Deep groove ball bearing with self-aligning ring single row (metric dimensions)

TRCEI..

Technical specification	EN 3727
Product standard	EN 4041

1.8

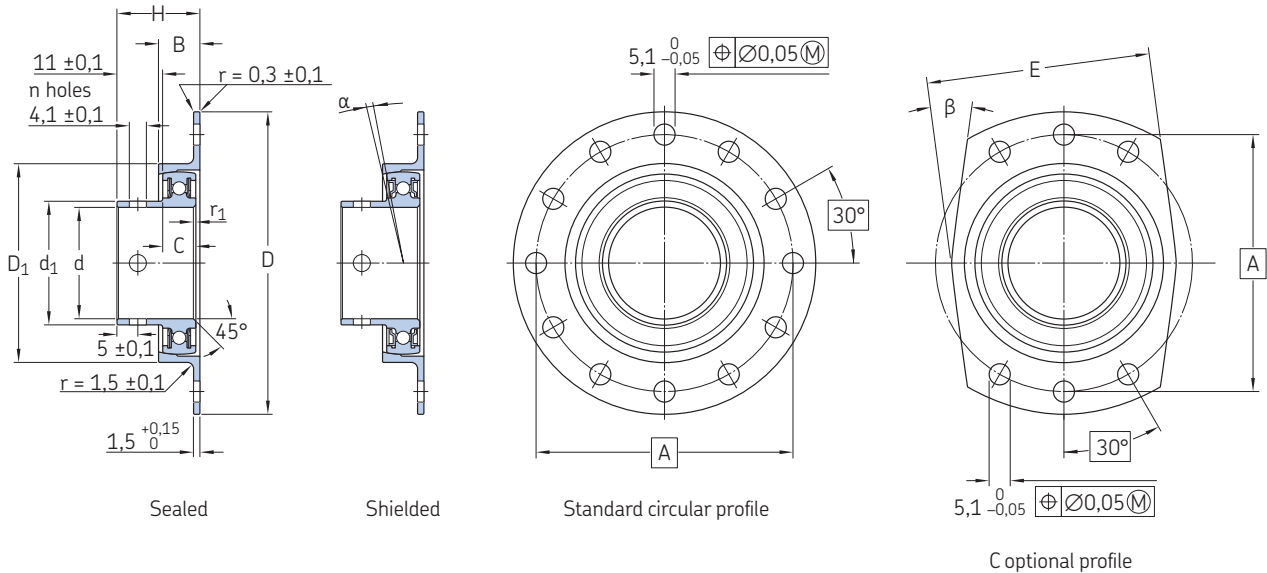

Dimensions

Nominal bore code	Dimensions		Δds	D $\pm 0,2$	C	B	d_1	A	H	D_1	n	r_1	E	α	β		
	d	Δdmp															
	mm	μm		mm		$\pm 0,15$	0		$\pm 0,15$	$\pm 0,05$		$+0,3$	± 1		$\pm 1^\circ$		
			For products per EN standard	For other products (J7)	For products per EN standard	For other products	0					-0,2					
					0/-0,12	0/-0,1	-0,1										
32	32	0/-12	+14/-11	+3/-15	77	7	7	9	35	66	19	52	4	0,5	55	2,5	24
35	35	0/-12	+14/-11	+3/-15	80	7	7	9	38	69	19	55	4	0,5	58	2,3	24
40	40	0/-12	+14/-11	+3/-15	86	8	8	10	43	75	20	61	4	0,5	64	2	30
45	45	0/-12	+14/-11	+3/-15	91	8	8	10	48	80	20	66	4	0,5	68	2	30
50	50	0/-12	+14/-11	+3/-15	97	8	8	10	53	86	20	72	6	0,5	74	1,7	30
63	63	0/-15	+18/-12	+4/-19	111	9	9	11	67	100	21	86	6	0,5	90	1,5	44

Loads, clearance and torque

Nominal bore code	Mass	C optional profile	Static limit load	Clearances		Axial max between outer and inner rings	Maximum starting torque		Swivelling torque	
				Radial C_s	For products per EN standard		For other products	Shielded	Sealed	Standard
	g		kN	μm			mNm		Nm	
32	107	91	24,5	2/7	5/13	120	21	30	5/10	1/4
35	125	97	25,5	2/9	5/13	120	27	35	5/11	1/4
40	143	121	29,5	2/9	5/13	120	33	44	8/14	1,3/4,5
45	155	136	32,4	2/9	5/13	120	39	53	9/15	1,3/4,5
50	175	152	35,3	2/9	5/13	120	48	68	9/18	1,5/5
63	235	205	39,2	2/9	5/13	120	83	113	10/20	2/6

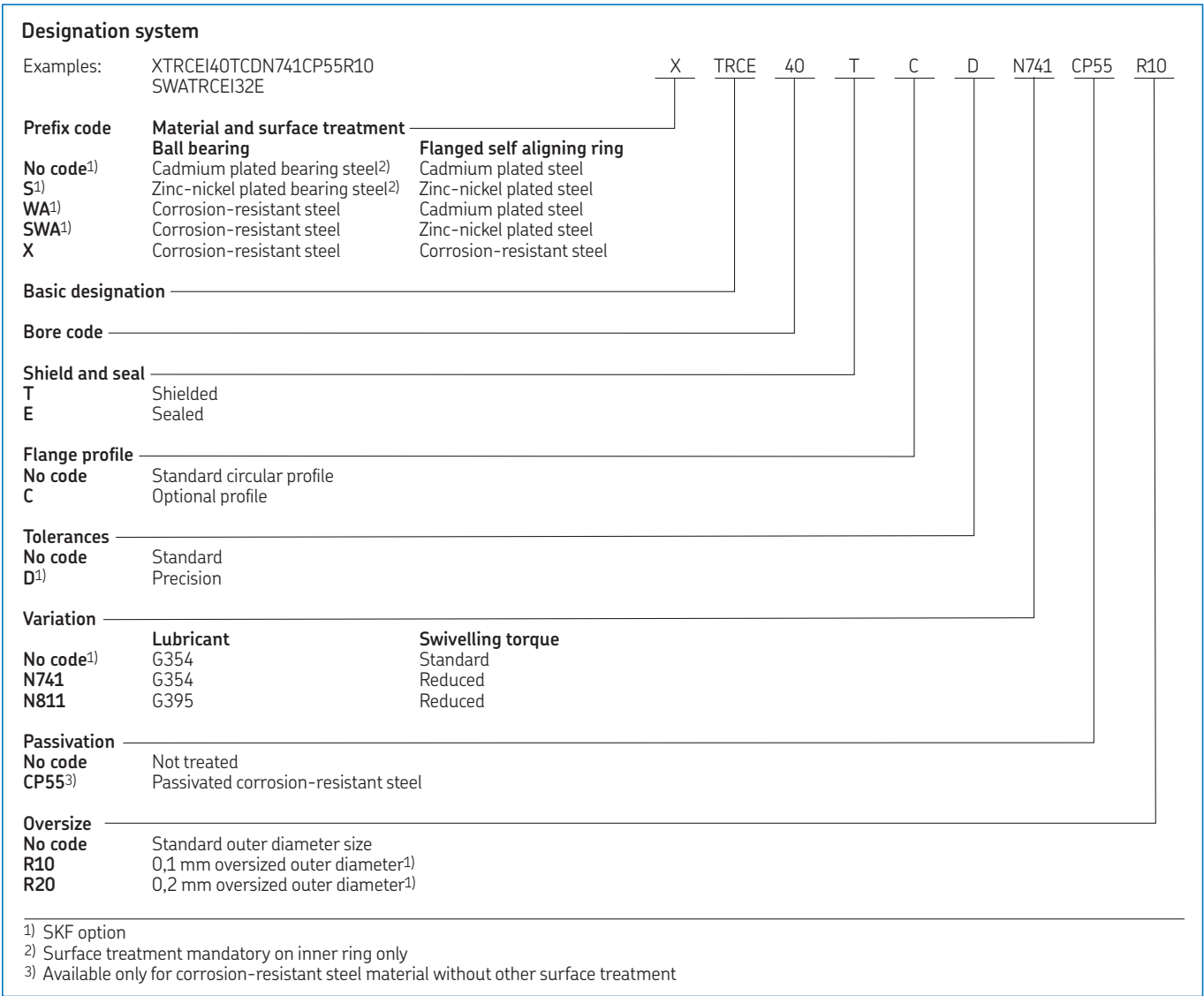

Tolerances

Nominal bore code	Tolerances		Kea max Standard	Precision	Sia max Standard	Precision	Sea max Standard	Precision
	Kia max Standard	Precision Without self-aligning ring						
–	µm							
32	25	10	40	10	40	20	40	20
35	25	10	40	10	40	20	40	20
40	25	10	40	10	40	20	40	20
45	25	10	40	10	40	20	40	20
50	25	10	40	10	40	20	40	20
63	25	10	40	10	40	20	40	20

1.9 Self-aligning ball bearing double row (metric dimensions)

KN..

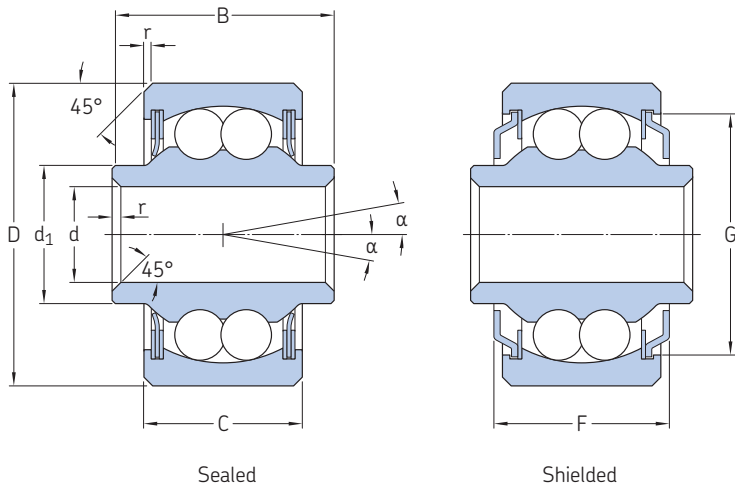

Technical specification	EN 3280
Product standard	EN 3287 (Bearing steel) EN 3288 (Bearing steel cadmium plated) EN 3289 (Corrosion-resistant steel)

Dimensions

Nominal bore code	Dimensions		Δd_{mp}	Δd_s	D	ΔD_{mp}	ΔD_s	C	B	$d_1 \approx$	F max	G max	r	α	Mass \approx
	Shielded	Sealed													
–		mm	μm		mm	μm		mm						°	g
5	5	5	0/-8	+2/-10	16	0/-8	+2/-10	8	12	7,6	10,0	12,0	0,5	6	9
6	6	6	0/-8	+2/-10	19	0/-9	+2/-11	10	14	8,6	12,0	14,4	0,5	6	14
8/24	8	8	0/-8	+2/-10	24	0/-9	+2/-11	10	15	11,1	13,0	19,8	0,5	6	30
10	10	10	0/-8	+2/-10	30	0/-9	+2/-11	14	20	13,6	17,0	24,0	0,5	6	57
12	12	12	0/-8	+3/-11	32	0/-11	+3/-14	14	20	15,4	17,0	26,5	0,5	6	62
15	15	15	0/-8	+3/-11	35	0/-11	+3/-14	14	20	18,5	17,0	30,0	0,5	6	75
17	17	17	0/-10	+3/-11	40	0/-11	+3/-14	16	22	21,2	19,0	34,0	0,5	6	110
20	20	20	0/-10	+3/-13	47	0/-11	+3/-14	18	24	23,6	20,0	39,7	0,5	6	170

Tolerances, loads and torque

Nominal bore code	Tolerances		Kea max		Static limit loads		Maximum starting torque		Maximum swivelling torque	
	Shielded	Sealed	Kia max Standard	Precision	Standard	Precision	Radial C_s	Axial C_a		Shielded
–		μm					kN		mNm	Nm
5	5	25	6	40	8	3,9	1,2	4	8	0,1
6	6	25	6	40	10	5,9	1,8	4,5	9	0,1
8/24	8	25	6	40	10	9,8	3,0	5,5	10	0,1
10	10	25	6	40	10	14,2	4,5	7,5	12	0,1
12	12	25	7	40	10	16,7	5,2	9	14	0,1
15	15	25	7	40	10	19	5,9	12	18	0,1
17	17	25	7	40	10	24,5	7,7	18	25	0,1
20	20	25	8	40	10	34,3	10,7	23	35	0,1



Designation system

Examples: ZWKN10EDN743CP55R10
KN 6N745

Surface treatment

No code Not plated steel
Z Cadmium plated steel
SZ¹⁾ Zinc-nickel plated steel

Material

No code Bearing steel
W Corrosion-resistant steel

Basic designation

Bore code

Shield and seal

No code Shielded
E Sealed

Tolerances

No code Standard
D¹⁾ Precision

Variation

J6-12 (for bore code ≤ 6)¹⁾

J8-14 (for bore code 8 to 15)¹⁾

J10-17 (for bore code ≥ 17)¹⁾

J6-12G81 (for bore code ≤ 6)¹⁾

J8-14G81 (for bore code 8 to 15)¹⁾

J10-17G81 (for bore code ≥ 17)¹⁾

N745²⁾

N815

N813³⁾

N743⁴⁾

N746⁵⁾

N816⁶⁾

Lubricant

G354

G354

G354

G395

G395

G395

G354

G395

G395

G354

G354

G395

Clearances

Increased radial

Increased radial

Increased radial

Increased radial

Increased radial

Increased radial

Reduced radial and axial

Reduced radial and axial

Standard radial and axial

Standard radial and axial

Group 3 radial and axial

Group 3 radial and axial

Passivation

No code Not treated
CP55⁷⁾ Passivated corrosion-resistant steel

Oversize

No code Standard outer diameter size
R10¹⁾ 0,1 mm oversized outer diameter
R20¹⁾ 0,2 mm oversized outer diameter

¹⁾ SKF option

²⁾ Replaces no code, ³⁾ Replaces N811, ⁴⁾ Replaces N741, ⁵⁾ Replaces N742, ⁶⁾ Replaces N812

⁷⁾ SKF option, available only for corrosion-resistant steel material without other surface treatment

Clearance

Nominal bore code Clearances

Shielded	Sealed	Standard Radial	Axial max	Reduced Radial	Axial max	Group 3 Radial	Axial max	Increased Radial
– μm								
5	5	2/13	100	2/6	70	10/20	100	6/12
6	6	2/13	100	2/6	70	10/20	100	6/12
8/24	8	2/13	100	2/7	80	10/20	100	8/14
10	10	2/13	120	2/7	80	10/20	120	8/14
12	12	3/18	120	3/9	80	13/23	120	8/14
15	15	3/18	120	3/9	80	13/23	120	8/14
17	17	3/18	160	3/9	80	13/23	160	10/17
20	20	5/20	180	5/10	80	15/25	180	10/17

1.10 Self-aligning ball bearing double row (metric dimensions)

KNRCE..

Technical specification	EN 3280
Product standard	EN 4034

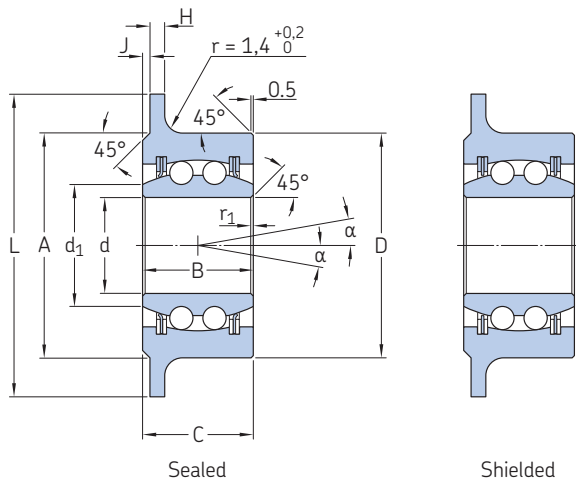

Dimensions and tolerances

Nominal bore code	Dimensions													Mass ≈		
	d	Δd_{mp}	Δd_s	D	ΔD_{mp}	ΔD_s	C	B	d_1	A	L	J	H		r_1	α
	mm	μm		mm	μm		mm	mm	mm	mm	mm	mm	mm	mm	°	g
15	15	0/-8	+3/-11	33	0/-11	+3/-14	13	13	19,6	34	41	1	1,5	0,2	2°30'	61
16	16	0/-8	+3/-11	33	0/-11	+3/-14	13	13	19,6	34	41	1	1,5	0,2	2°30'	58
20	20	0/-9	+3/-13	38	0/-13	+3/-14	13	13	24,7	39	46	1	1,5	0,2	2°30'	74
25	25	0/-10	+3/-13	43	0/-13	+3/-14	14	14	28,6	44	51	1	1,5	0,2	2°30'	90
32	32	0/-10	+3/-13	52	0/-13	+4/-17	14	14	38,0	55	60	2	2	0,2	2°30'	132
35 ¹⁾	35	0/-11	+3/-15	55	0/-15	+4/-17	14	14	40,6	58	63	2	2	0,2	2°30'	141
40 ¹⁾	40	0/-11	+3/-15	61	0/-15	+4/-17	16	16	45,3	64	69	2	2	0,2	2°30'	183

Tolerances cont., loads, clearance and torque

Nominal bore code	Tolerances				Static limit loads		Radial clearance	Maximum starting torque		Maximum swivelling torque
	Kia max Standard	Precision	Kea max Standard	Precision	Radial C_s	Axial C_a		Shielded	Sealed	
	μm				kN		μm	mNm		Nm
15	25	7	40	10	15,7	5,3	3/9	12	18	0,1
16	25	7	40	10	15,7	5,3	3/9	12	18	0,1
20	25	8	40	10	19	5,3	5/10	23	35	0,1
25	25	8	40	10	21,6	5,3	5/10	30	42	0,1
32	25	8	40	10	27,5	5,3	10/18	40	55	0,1
35 ¹⁾	25	10	40	10	29,1	5,3	10/18	44	66	0,15
40 ¹⁾	25	10	40	10	32,5	5,3	10/18	50	75	0,15

¹⁾ SKF option



Designation system

Examples:	Z	W	KNRCE	20	E	D	N743	CP55	R10
ZWKNRCE20EDN743CP55R10 KNRCE15N813									
Surface treatment	_____								
No code	Not plated steel								
Z¹⁾	Cadmium plated steel								
SZ¹⁾	Zinc-nickel plated steel								
Material	_____								
No code¹⁾	Bearing steel								
W	Corrosion-resistant steel								
Basic designation	_____								
Bore code	_____								
Shield and seal	_____								
No code	Shielded								
E	Sealed								
Tolerances	_____								
No code	Standard								
D¹⁾	Precision								
Variation	_____								
	Lubricant								
N743²⁾	G354								
N813	G395								
Passivation	_____								
No code	Not treated								
CP55³⁾	Passivated corrosion-resistant steel								
Oversize	_____								
No code	Standard outer diameter size								
R10¹⁾	0,1 mm oversized outer diameter								
R20¹⁾	0,2 mm oversized outer diameter								

1) SKF option

2) Replaces no code

3) Available only for corrosion-resistant steel material without other surface treatment

1.11 Spherical roller bearing single row (metric dimensions)

K..F, KN..F, K..FE..SP1, KN..FE..SP1

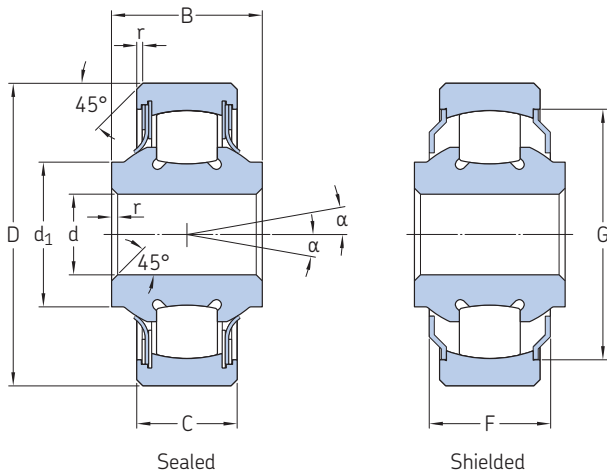

Technical specification	EN 3280
Product standard	EN 3053 (Bearing steel) EN 3054 (Bearing steel cadmium plated) EN 3055 (Corrosion-resistant steel)

Dimensions

Nominal bore code	Shielded	Sealed	Dimensions			D	ΔDmp	ΔDs	C	B	d ₁	F max	G max	r	α	Shielded	Sealed
			d	Δdmp	Δds												
			mm	μm	mm	μm	mm	mm	mm	mm	mm	mm	mm	mm	°		
6	–	–	6	0/–8	+2/–10	24	0/–9	+2/–11	8	12	11,9	10	20,5	0,5	6	–	–
8	–	8FE..SP1	8	0/–8	+2/–10	26	0/–9	+2/–11	10	15	12,3	13	22	0,5	6	4	–
N 8	–	N 8FE..SP1	8	0/–8	+2/–10	30	0/–9	+2/–11	10	15	14,3	12	25	0,5	6	1,5	–
10	–	–	10	0/–8	+2/–10	35	0/–11	+3/–14	12	16	16,9	13	29	0,5	6	–	–
N10	–	–	10	0/–8	+2/–10	35	0/–11	+3/–14	12	20	16,9	17	29	0,5	6	–	–
N12	–	–	12	0/–8	+3/–11	40	0/–11	+3/–14	13	20	19,9	17	33,5	0,5	6	–	–
N15	–	–	15	0/–8	+3/–11	47	0/–11	+3/–14	14	24	23,9	20	40	0,5	6	–	–
17	–	–	17	0/–8	+3/–11	47	0/–11	+3/–14	15	24	25,9	20	41	0,5	6	–	–

Tolerances, loads, clearance and torque

Nominal bore code	Shielded	Sealed	Mass ≈	Tolerances		Kea max Standard	Precision	Static limit loads		Clearances		Maximum starting torque
				Kia max Standard	Precision			Radial C _s	Axial C _a	Radial	Axial max	
			g	μm	μm			kN		μm		mNm
6	–	–	21	25	6	40	10	15,9	4,8	2/6	180	6
8	–	8FE..SP1	37	25	6	40	10	22,8	6,9	2/7	210	8
N 8	–	N 8FE..SP1	49	25	6	40	10	27,8	8,4	2/7	210	12
10	–	–	70	25	6	40	10	32,9	10,0	2/7	210	16
N10	–	–	72	25	6	40	10	32,9	10,0	2/7	210	16
N12	–	–	108	25	7	40	10	45	13,6	3/9	210	20
N15	–	–	153	25	7	40	10	54,2	16,4	3/9	210	25
17	–	–	163	25	7	40	10	69,4	21,0	3/9	210	30



Designation system

Examples:	ZWK10FEDSP1CP55R10	Z	W	K	10	F	E	D	SP1	CP55	R10
	KN 8FN743										
Surface treatment of outer ring											
No code	Not plated										
Z	Cadmium plated external dimensions										
SZ¹⁾	Zinc-nickel plated external dimensions										
Material											
No code	Bearing steel inner ring and outer ring										
W	Corrosion-resistant steel inner ring and outer ring										
Basic designation											
Bore code											
Tolerances											
No code	Standard										
D¹⁾	Precision										
Variation											
	Shield and seal										
		Lubricant									
N743²⁾	Shielded	G354									
N813	Shielded	G395									
E..SP1¹⁾⁴⁾	Sealed	G354									
E..SP1G81¹⁾⁴⁾	Sealed	G395									
Passivation											
No code	Not treated										
CP55³⁾	Passivated corrosion-resistant steel										
Oversize											
No code	Standard outer diameter size										
R10¹⁾	0,1 mm oversized outer diameter										
R20¹⁾	0,2 mm oversized outer diameter										

1) SKF option

2) Replaces no code,

3) SKF option, available only for corrosion-resistant steel material without other surface treatment

4) Only available for bore code 8 and N8

1.12 Spherical roller bearing single row (metric dimensions)

KNA..F

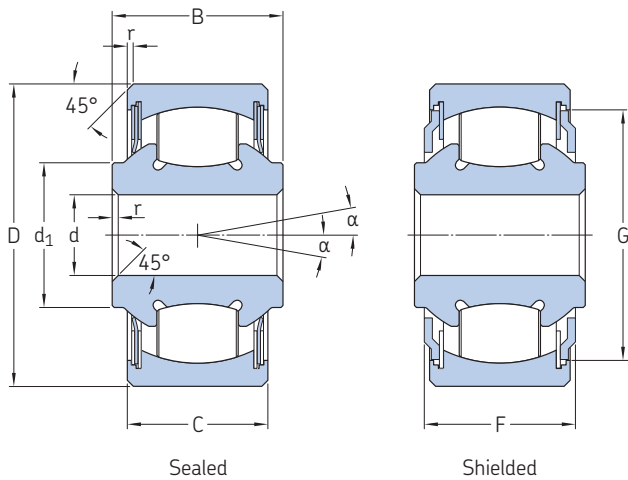

Technical specification	EN 3280
Product standard	EN 3290 (Bearing steel) EN 3291 (Bearing steel cadmium plated) EN 3292 (Corrosion-resistant steel)

Dimensions

Nominal bore code	Dimensions		Δds	D	ΔD		C	B	d_1	F	G	r	α	Mass
	d	Δd			ΔD_{mp}	ΔD_s								
–	mm	μm		mm	μm		mm			max	max	+0,3 –0,2	°	g
8	8	0/–8	+2/–10	30	0/–9	+3/–14	14	17	14	14	24,9	0,5	7	58
10	10	0/–8	+2/–10	35	0/–11	+3/–14	17	21	15,7	18	28	0,5	7	91
12	12	0/–8	+3/–11	37	0/–11	+3/–14	17	21	18	18	30,7	0,5	7	106
15	15	0/–8	+3/–11	42	0/–11	+3/–14	17	21	21,8	18	35,5	0,5	7	132
17	17	0/–8	+3/–11	47	0/–11	+4/–14	19	23	25,1	19	39,3	0,5	7	186
20	20	0/–8	+3/–13	52	0/–13	+4/–17	21	26	28	22	44,8	0,5	7	246
25	25	0/–10	+3/–13	62	0/–13	+4/–17	24	29	34,5	25	53,3	0,5	7	397
30	30	0/–10	+3/–13	72	0/–13	+4/–17	27	34	41,3	30	63	0,5	7	610

Tolerances, loads, clearance and torque

Nominal bore code	Tolerances				Static limit loads		Clearances				Maximum starting torque	
	Kia max	Precision	Kea max	Precision	Radial	Axial	Standard	Axial	Reduced	Axial	Shielded	Sealed
–	μm		μm		kN		μm				mNm	
8	25	6	40	10	41,2	12,4	10/20	230	2/7	190	7	11
10	25	6	40	10	58,8	17,7	10/20	230	2/7	190	10	15,5
12	25	7	40	10	68,6	20,6	10/20	240	3/9	200	15	23
15	25	7	40	10	70,6	21,2	10/20	240	3/9	200	20	30
17	25	7	40	10	95	28,6	10/20	240	3/9	200	25	38
20	25	8	40	10	114	34,3	10/20	250	3/10	220	30	45
25	25	8	40	10	162,5	49	15/25	290	3/10	240	35	52
30	25	8	40	10	217,6	65,3	15/25	290	3/10	240	40	60



Designation system

Examples:	Z	W	KNA	10	F	E	D	N743	CP55	R10
ZWKNA10FEDN743CP55R10 KNA 8FN813										
Surface treatment	_____									
No code	Not plated steel									
Z	Cadmium plated steel									
SZ¹⁾	Zinc-nickel plated steel									
Material	_____									
No code	Bearing steel									
W	Corrosion-resistant steel									
Basic designation	_____									
Bore code	_____									
Shield and seal	_____									
No code	Shielded									
E	Sealed									
Tolerances	_____									
No code	Standard									
D¹⁾	Precision									
Variation	_____									
N745²⁾	Lubricant	Clearances								
N815	G354	Reduced radial and axial								
N813³⁾	G395	Reduced radial and axial								
N743⁴⁾	G395	Standard radial and axial								
	G354	Standard radial and axial								
Passivation	_____									
No code	Not treated									
CP55⁵⁾	Passivated corrosion-resistant steel									
Oversize	_____									
No code	Standard outer diameter size									
R10¹⁾	0,1 mm oversized outer diameter									
R20¹⁾	0,2 mm oversized outer diameter									

1) SKF option

2) Replaces no code

3) Replaces N811

4) Replaces N741

5) SKF option, available only for corrosion-resistant steel material without other surface treatment

1.13 Spherical roller bearing double row (metric dimensions)

K..D

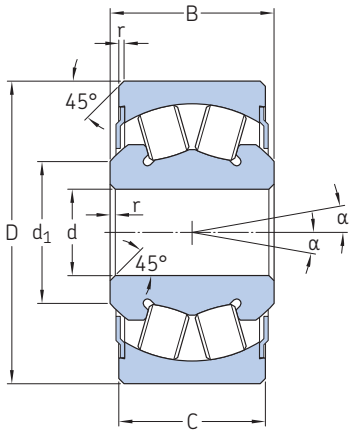

Technical specification	-
Product standard	-

1.13

Dimension

Nominal bore code	Dimensions			D	ΔD_{mp}	ΔD_s	C	B	d_1	r	α	Mass
	d	Δd_{mp}	Δd_s									
-	mm	μm		mm	μm		mm				$^\circ$	g
10/21	10	0/-8	+2/-10	35	0/-11	+3/-14	17	21	17,4	0,5	5	95
10	10	0/-8	+2/-10	35	0/-11	+3/-14	17	24	17,4	0,5	5	113
12/21	12	0/-8	+3/-11	35	0/-11	+3/-14	17	21	17,4	0,5	5	90

Tolerances, loads, clearance and torque

Nominal bore code	Tolerances		Static limit loads		Axial clearance	Maximum starting torque
	Kia max	Kea max	Radial C_s	Axial C_a		
-	μm		kN		μm	mNm
10/21	25	40	54,3	16,3	0/300	30
10	25	40	54,3	16,3	0/300	30
12/21	25	40	54,3	16,3	0/300	30



Designation system

Examples:	ZWK10/21DG81CP55R10	Z	W	K	10/21	D	G81	CP55	R10
Surface treatment									
No code	Not plated steel								
Z	Cadmium plated steel								
SZ	Zinc-nickel plated steel								
Material									
No code	Bearing steel								
W	Corrosion-resistant steel								
Basic designation									
Bore code									
Lubrication									
No code	Grease G354								
G81	Grease G395								
Passivation									
No code	Not treated								
CP55¹⁾	Passivated corrosion-resistant steel								
Oversize									
No code	Standard outer diameter size								
R10	0,1 mm oversized outer diameter								
R20	0,2 mm oversized outer diameter								

¹⁾ Available only for corrosion-resistant steel material without other surface treatment

1.14 Deep groove ball bearing single row (inch dimensions)

KP., KP..L

Technical specification	AS 7949
Product standard	AS 27640

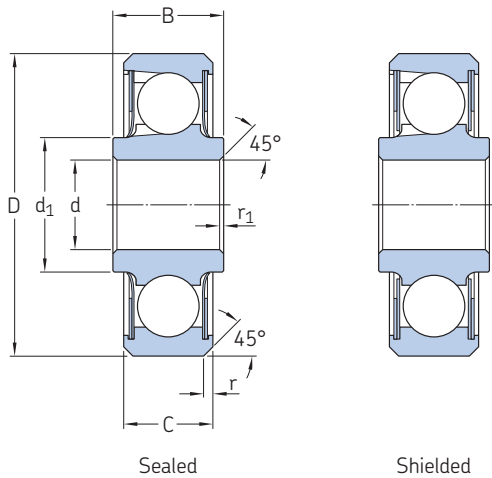

Dimensions

Nominal Dimensions

bore code	d	Δ dmp Standard	SKF super precision	Δ ds	D	Δ Dmp Standard	SKF super precision	Δ Ds	C	Δ Cs Standard	SKF super precision	
–	in/mm											
3L	0.1900 4,826	0/-0.0005 0/-0,0127	0/-0.0003 0/-0,0076	+0.0002/-0.0007 +0,0050/-0,0178	0.6250 15,875	0/-0.0005 0/-0,0127	0/-0.0004 0/-0,0101	+0.0005/-0.0010 +0,0127/-0,0254	0,203 5,156	0/-0.005 0/-0,127	0/-0.005 0/-0,127	
3	0.1900 4,826	0/-0.0005 0/-0,0127	0/-0.0003 0/-0,0076	+0.0002/-0.0007 +0,0050/-0,0178	0.7774 19,745	0/-0.0005 0/-0,0127	0/-0.0004 0/-0,0101	+0.0005/-0.0010 +0,0127/-0,0254	0,270 6,858	0/-0.005 0/-0,127	0/-0.005 0/-0,127	
4	0.2500 6,350	0/-0.0005 0/-0,0127	0/-0.0003 0/-0,0076	+0.0002/-0.0007 +0,0050/-0,0178	0.9014 22,895	0/-0.0005 0/-0,0127	0/-0.0004 0/-0,0101	+0.0005/-0.0010 +0,0127/-0,0254	0,335 8,509	0/-0.005 0/-0,127	0/-0.005 0/-0,127	
5	0.3125 7,938	0/-0.0005 0/-0,0127	0/-0.0003 0/-0,0076	+0.0002/-0.0007 +0,0050/-0,0178	1.2500 31,750	0/-0.0005 0/-0,0127	0/-0.0004 0/-0,0101	+0.0005/-0.0010 +0,0127/-0,0254	0,375 9,525	0/-0.005 0/-0,127	0/-0.005 0/-0,127	
6	0.3750 9,525	0/-0.0005 0/-0,0127	0/-0.0003 0/-0,0076	+0.0002/-0.0007 +0,0050/-0,0178	1.4375 36,513	0/-0.0005 0/-0,0127	0/-0.0004 0/-0,0101	+0.0005/-0.0010 +0,0127/-0,0254	0,469 11,912	0/-0.005 0/-0,127	0/-0.005 0/-0,127	
8	0.5000 12,700	0/-0.0005 0/-0,0127	0/-0.0003 0/-0,0076	+0.0002/-0.0007 +0,0050/-0,0178	1.6875 42,862	0/-0.0005 0/-0,0127	0/-0.0004 0/-0,0101	+0.0005/-0.0010 +0,0127/-0,0254	0,500 12,700	0/-0.005 0/-0,127	0/-0.005 0/-0,127	
10	0.6250 15,875	0/-0.0005 0/-0,0127	0/-0.0003 0/-0,0076	+0.0002/-0.0007 +0,0050/-0,0178	1.9375 49,212	0/-0.0005 0/-0,0127	0/-0.0004 0/-0,0101	+0.0005/-0.0010 +0,0127/-0,0254	0,500 12,700	0/-0.005 0/-0,127	0/-0.005 0/-0,127	

Dimensions cont. and tolerances

Nominal bore code	Dimensions			d_1	r_1 +0,015/0 +0,381/0	r +0.015/0 +0,381/0	Mass ≈ lb/g	Tolerances		Kea max Standard	SKF super precision	Sia max Standard	SKF super precision
	B	Δ Bs Standard	SKF super precision					Kia max Standard	SKF super precision				
–	in/mm												
3L	0.245 6,223	0/-0.005 0/-0,127	0/-0.0025 0/-0,0635	0.280 7,112	0.005 0,127	0.010 0,254	0.01 4,5	0.0010 0,0254	0.0005 0,0127	0.0016 0,0406	0.0008 0,0203	0.0010 0,0254	0.0007 0,0178
3	0.297 7,543	0/-0.005 0/-0,127	0/-0.0025 0/-0,0635	0.331 8,407	0.005 0,127	0.022 0,559	0.03 14	0.0010 0,0254	0.0005 0,0127	0.0016 0,0406	0.0008 0,0203	0.0010 0,0254	0.0007 0,0178
4	0.484 12,293	0/-0.005 0/-0,127	0/-0.0025 0/-0,0635	0.390 9,906	0.005 0,127	0.032 0,813	0.04 18	0.0010 0,0254	0.0005 0,0127	0.0016 0,0406	0.0008 0,0203	0.0010 0,0254	0.0007 0,0178
5	0.558 14,173	0/-0.005 0/-0,127	0/-0.0025 0/-0,0635	0.469 11,912	0.015 0,381	0.032 0,813	0.09 41	0.0010 0,0254	0.0005 0,0127	0.0016 0,0406	0.0008 0,0203	0.0010 0,0254	0.0007 0,0178
6	0.620 15,748	0/-0.005 0/-0,127	0/-0.0025 0/-0,0635	0.591 15,011	0.015 0,381	0.032 0,813	0.15 68	0.0010 0,0254	0.0005 0,0127	0.0016 0,0406	0.0008 0,0203	0.0010 0,0254	0.0007 0,0178
8	0.620 15,748	0/-0.005 0/-0,127	0/-0.0025 0/-0,0635	0.768 19,507	0.015 0,381	0.044 1,118	0.21 95	0.0010 0,0254	0.0005 0,0127	0.0016 0,0406	0.0008 0,0203	0.0010 0,0254	0.0007 0,0178
10	0.620 15,748	0/-0.005 0/-0,127	0/-0.0025 0/-0,0635	0.850 21,590	0.015 0,381	0.044 1,118	0.28 127	0.0010 0,0254	0.0005 0,0127	0.0016 0,0406	0.0008 0,0203	0.0010 0,0254	0.0007 0,0178



Designation system

Examples: ZWMKP10SK2CP55RP01
 KP 3LP

Material and surface treatment

No code Cadmium plated bearing steel
W¹⁾ Corrosion-resistant steel
S Zinc-nickel plated bearing steel
ZW¹⁾ Cadmium plated corrosion-resistant steel
SZW¹⁾ Zinc-nickel plated corrosion-resistant steel

Tolerances

No code Standard tolerances
M¹⁾ Reduced clearance and SKF super precision

Basic designation

Bore code (multiples of 1/16th inch)

Variation

	Lubricant	Version	Radial clearance KP..	MKP.. ¹⁾
SK2	G354	Sealed	Standard	Reduced
S281	G395	Sealed	Standard	Reduced
S281-R	G395	Sealed	Reduced	–
SK2-R	G354	Sealed	Reduced	–
P¹⁾	G354	Shielded	Standard	Reduced
PG81¹⁾	G395	Shielded	Standard	Reduced
PG81-R¹⁾	G395	Shielded	Reduced	–
P-R¹⁾	G354	Shielded	Reduced	–

Passivation

No code Not treated
CP55²⁾ Passivated corrosion-resistant steel

Oversize

No code Standard outer diameter size
RP01¹⁾ 0.010 in/0,254 mm oversized outer diameter
RP02¹⁾ 0.020 in/0,508 mm oversized outer diameter

1) SKF option

2) SKF option, available only for corrosion-resistant steel material without other surface treatment

Tolerances cont., loads, clearance and torque

Nominal bore code	Tolerances		Static limit loads		Radial dynamic load rating ³⁾⁴⁾		Radial clearance		Maximum starting torque ⁵⁾	
	Sea max Standard	SKF super precision	Radial C _s	Axial C _a	Load fixed with respect to outer ring inner ring		Standard	Reduced	Shielded	Sealed
–	in/mm		lbf/kN		lbf/kN		in/mm		oz-in/mNm	
3L	0.0016	0.0010	1 560	700	1 520	1 260	0.0004/ 0.0010	0.0002/ 0.0005	0.67	1
	0,0406	0,0254	6,94	3,11	6,76	5,60	0,0101/ 0,0254	0,0051/ 0,0127	4,71	7,06
3	0.0016	0.0010	1 880	900	1 700	1 450	0.0004/ 0.0010	0.0002/ 0.0005	0.67	1
	0,0406	0,0254	8,36	4,00	7,56	6,45	0,0101/ 0,0254	0,0051/ 0,0127	4,71	7,06
4	0.0016	0.0010	2 680	1 200	2 410	2 030	0.0004/ 0.0010	0.0002/ 0.0005	0.67	1
	0,0406	0,0254	11,92	5,34	10,72	9,03	0,0101/ 0,0254	0,0051/ 0,0127	4,71	7,06
5	0.0016	0.0010	5 620	2 500	4 900	3 970	0.0004/ 0.0010	0.0002/ 0.0005	0.67	1
	0,0406	0,0254	25,00	11,12	21,8	17,66	0,0101/ 0,0254	0,0051/ 0,0127	4,71	7,06
6	0.0016	0.0010	7 910	3 500	6 540	5 410	0.0004/ 0.0010	0.0002/ 0.0005	1.33	2
	0,0406	0,0254	35,18	15,57	29,09	24,06	0,0101/ 0,0254	0,0051/ 0,0127	9,41	14,12
8	0.0016	0.0010	11 800	5 200	9 320	7 700	0.0004/ 0.0010	0.0002/ 0.0005	2	3
	0,0406	0,0254	52,49	23,13	41,46	34,25	0,0101/ 0,0254	0,0051/ 0,0127	14,12	21,18
10	0.0016	0.0010	14 100	6 200	11 000	9 060	0.0004/ 0.0010	0.0002/ 0.0005	2	4
	0,0406	0,0254	62,72	27,58	48,93	40,3	0,0101/ 0,0254	0,0051/ 0,0127	14,12	28,25

3) For average life of 10 000 cycles at $\theta = 90^\circ$ oscillation, see page 38

4) If G395 load rating is 20% lower

5) Values are valid for bearings with G395. When using G354, values are 20% higher

1.15 Deep groove ball bearing single row (inch dimensions)

KP..A bore code 3 to 8

Technical specification	AS 7949
Product standard	AS 27641

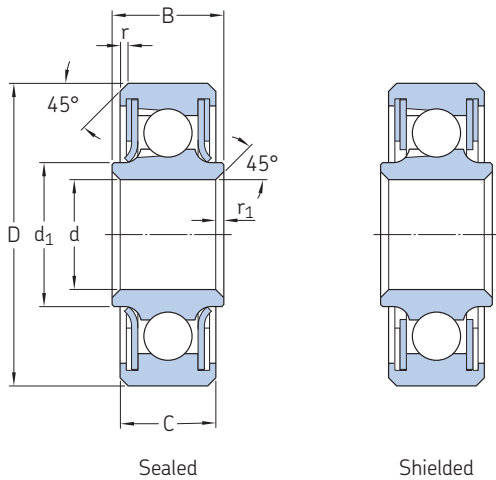

1.15



Dimensions

Nominal Dimensions

bore code	d	Δd_{mp} Standard	SKF super precision	Δd_s	D	ΔD_{mp} Standard	SKF super precision	ΔD_s	C	ΔC_s Standard	SKF super precision
–	in/mm										
3	0.1900 4,826	0/-0.0005 0/-0,0127	0/-0.0003 0/-0,0076	+0.0002/-0.0007 +0,0050/-0,0178	0.6250 15,875	0/-0.0005 0/-0,0127	0/-0.0004 0/-0,0101	+0.0005/-0.0010 +0,0127/-0,0254	0.234 5,943	0/-0.005 0/-0,127	0/-0.005 0/-0,127
4	0.2500 6,350	0/-0.0005 0/-0,0127	0/-0.0003 0/-0,0076	+0.0002/-0.0007 +0,0050/-0,0178	0.7500 19,050	0/-0.0005 0/-0,0127	0/-0.0004 0/-0,0101	+0.0005/-0.0010 +0,0127/-0,0254	0.219 5,562	0/-0.005 0/-0,127	0/-0.005 0/-0,127
5	0.3125 7,938	0/-0.0005 0/-0,0127	0/-0.0003 0/-0,0076	+0.0002/-0.0007 +0,0050/-0,0178	0.8125 20,638	0/-0.0005 0/-0,0127	0/-0.0004 0/-0,0101	+0.0005/-0.0010 +0,0127/-0,0254	0.234 5,943	0/-0.005 0/-0,127	0/-0.005 0/-0,127
6	0.3750 9,525	0/-0.0005 0/-0,0127	0/-0.0003 0/-0,0076	+0.0002/-0.0007 +0,0050/-0,0178	0.8750 22,225	0/-0.0005 0/-0,0127	0/-0.0004 0/-0,0101	+0.0005/-0.0010 +0,0127/-0,0254	0.250 6,350	0/-0.005 0/-0,127	0/-0.005 0/-0,127
8	0.5000 12,700	0/-0.0005 0/-0,0127	0/-0.0003 0/-0,0076	+0.0002/-0.0007 +0,0050/-0,0178	1.1250 28,575	0/-0.0005 0/-0,0127	0/-0.0004 0/-0,0101	+0.0005/-0.0010 +0,0127/-0,0254	0.313 7,950	0/-0.005 0/-0,127	0/-0.005 0/-0,127

Dimensions cont. and tolerances

Nominal bore code	Dimensions			Mass			Tolerances								
	B	ΔB_s Standard	SKF super precision	d_1 ≈	r_1 +0.015/0 +0,381/0	r +0.015/0 +0,381/0	≈	Kia max Standard	SKF super precision	Kea max Standard	SKF super precision	Sia max Standard	SKF super precision		
–	in/mm											lb/g		in/mm	
3	0.297 7,543	0/-0.005 0/-0,127	0/-0.0025 0/-0,0635	0.297 7,543	0.005 0,127	0.016 0,406	0,01 4,5	0.0010 0,0254	0.0005 0,0127	0.0016 0,0406	0.0008 0,0203	0.0010 0,0254	0.0007 0,0178		
4	0.281 7,137	0/-0.005 0/-0,127	0/-0.0025 0/-0,0635	0.380 9,652	0.005 0,127	0.016 0,406	0,02 9	0.0010 0,0254	0.0005 0,0127	0.0016 0,0406	0.0008 0,0203	0.0010 0,0254	0.0007 0,0178		
5	0.297 7,543	0/-0.005 0/-0,127	0/-0.0025 0/-0,0635	0.415 10,541	0.015 0,381	0.016 0,406	0,02 9	0.0010 0,0254	0.0005 0,0127	0.0016 0,0406	0.0008 0,0203	0.0010 0,0254	0.0007 0,0178		
6	0.313 7,950	0/-0.005 0/-0,127	0/-0.0025 0/-0,0635	0.495 12,573	0.015 0,381	0.016 0,406	0,03 14	0.0010 0,0254	0.0005 0,0127	0.0016 0,0406	0.0008 0,0203	0.0010 0,0254	0.0007 0,0178		
8	0.375 9,525	0/-0.005 0/-0,127	0/-0.0025 0/-0,0635	0.616 15,646	0.015 0,381	0.016 0,406	0,05 22,6	0.0010 0,0254	0.0005 0,0127	0.0016 0,0406	0.0008 0,0203	0.0010 0,0254	0.0007 0,0178		



Designation system

Examples: ZWMKP10ASK2CP55RP01
 KP 8AP

Material and surface treatment

No code Cadmium plated bearing steel
W¹⁾ Corrosion-resistant steel
S Zinc-nickel plated bearing steel
ZW¹⁾ Cadmium plated corrosion-resistant steel
SZW¹⁾ Zinc-nickel plated corrosion-resistant steel

Tolerances

No code Standard tolerances
M¹⁾ Reduced clearance and SKF super precision

Basic designation

Bore code (multiples of 1/16th inch)

Variation

	Lubricant	Version	Radial clearance	
			KP..	MKP.. ¹⁾
SK2	G354	Sealed	Standard	Reduced
S281	G395	Sealed	Standard	Reduced
S281-R	G395	Sealed	Reduced	–
SK2-R	G354	Sealed	Reduced	–
P¹⁾	G354	Shielded	Standard	Reduced
PG81¹⁾	G395	Shielded	Standard	Reduced
PG81-R¹⁾	G395	Shielded	Reduced	–
P-R¹⁾	G354	Shielded	Reduced	–

Passivation

No code Not treated
CP55²⁾ Passivated corrosion-resistant steel

Oversize

No code Standard outer diameter size
RP01¹⁾ 0.010 in/0,254 mm oversized outer diameter
RP02¹⁾ 0.020 in/0,508 mm oversized outer diameter

1) SKF option

2) SKF option, available only for corrosion-resistant steel material without other surface treatment

Tolerances cont., loads, clearance and torque

Nominal bore code	Tolerances		Static limit loads		Radial dynamic load rating ³⁾⁴⁾		Radial clearance		Maximum starting torque ⁵⁾	
	Sea max Standard	SKF super precision	Radial C _s	Axial C _a	Load fixed with respect to outer ring inner ring		Standard	Reduced	Shielded	Sealed
–	in/mm		lbf/kN		lbf/kN		in/mm		oz-in/mNm	
3	0.0016 0,0406	0.0010 0,0254	1 560 6,94	700 3,11	1 500 6,67	1 250 5,56	0.0004/ 0.0010 0,0101/ 0,0254	0.0002/ 0.0005 0,0051/ 0,0127	0.67 4,73	1 7,06
4	0.0016 0,0406	0.0010 0,0254	1 880 8,36	900 4,00	1 690 7,52	1 450 6,45	0.0004/ 0.0010 0,0101/ 0,0254	0.0002/ 0.0005 0,0051/ 0,0127	1 7,06	1.5 10.59
5	0.0016 0,0406	0.0010 0,0254	2 190 9,74	1 000 4,45	1 820 8,10	1 600 7,12	0.0004/ 0.0010 0,0101/ 0,0254	0.0002/ 0.0005 0,0051/ 0,0127	1 7,06	1.5 10.59
6	0.0016 0,0406	0.0010 0,0254	2 500 11,12	1 100 4,89	1 920 8,54	1 710 7,61	0.0004/ 0.0010 0,0101/ 0,0254	0.0002/ 0.0005 0,0051/ 0,0127	1.33 9.41	2 14.12
8	0.0016 0,0406	0.0010 0,0254	3 910 17,39	1 700 7,56	2 870 12,77	2 550 11,34	0.0004/ 0.0010 0,0101/ 0,0254	0.0002/ 0.0005 0,0051/ 0,0127	1.67 11.77	2.5 17.65

3) For average life of 10 000 cycles at $\theta = 90^\circ$ oscillation, see page 38

4) If G395 load rating is 20% lower

5) Values are valid for bearings with G395. When using G354, values are 20% higher

1.15 Deep groove ball bearing single row (inch dimensions)

KP..A bore code **10** to **20**

Technical specification	AS 7949
Product standard	AS 27641

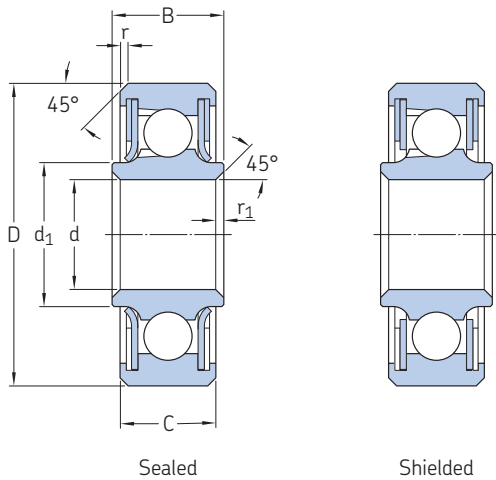

Dimensions

Nominal bore code	Dimensions		Δd_{mp} Standard	SKF super precision	Δd_s	D	ΔD_{mp}		ΔD_s	C	ΔC_s	
	d	Δd_{mp} Standard					Standard	SKF super precision			Standard	SKF super precision
–	in/mm											
10	0,6250 15,875	0/–0,0005 0/–0,0127	0/–0,0003 0/–0,0076	+0,0002/–0,0007 +0,0050/–0,0178	1,3750 34,925	0/–0,0005 0/–0,0127	0/–0,0004 0/–0,0101	+0,0005/–0,0010 +0,0127/–0,0254	0,344 8,737	0/–0,005 0/–0,127	0/–0,005 0/–0,127	
12	0,7500 19,050	0/–0,0005 0/–0,0127	0/–0,0003 0/–0,0076	+0,0002/–0,0007 +0,0050/–0,0178	1,6250 41,275	0/–0,0005 0/–0,0127	0/–0,0004 0/–0,0101	+0,0005/–0,0010 +0,0127/–0,0254	0,375 9,525	0/–0,005 0/–0,127	0/–0,005 0/–0,127	
16	1,0000 25,400	0/–0,0005 0/–0,0127	0/–0,0003 0/–0,0076	+0,0002/–0,0007 +0,0050/–0,0178	2,0000 50,800	0/–0,0005 0/–0,0127	0/–0,0004 0/–0,0101	+0,0005/–0,0010 +0,0127/–0,0254	0,438 11,125	0/–0,005 0/–0,127	0/–0,005 0/–0,127	
20	1,2500 31,750	0/–0,0005 0/–0,0127	0/–0,0003 0/–0,0076	+0,0002/–0,0007 +0,0050/–0,0178	2,2500 57,150	0/–0,0005 0/–0,0127	0/–0,0004 0/–0,0101	+0,0005/–0,0010 +0,0127/–0,0254	0,438 11,125	0/–0,005 0/–0,127	0/–0,005 0/–0,127	

Dimensions cont. and tolerances

Nominal bore code	Dimensions			d_1 ≈	r_1 +0,015/0 +0,381/0	r +0,015/0 +0,381/0	Mass ≈	Tolerances		Kea max Standard	SKF super precision	Sia max Standard	SKF super precision
	B	ΔB_s Standard	SKF super precision					Kia max Standard	SKF super precision				
–	in/mm												
10	0,406 10,312	0/–0,005 0/–0,127	0/–0,0025 0/–0,0635	0,768 19,507	0,015 0,381	0,032 0,813	0,08 36	0,0010 0,0254	0,0005 0,0127	0,0016 0,0406	0,0008 0,0203	0,0010 0,0254	0,0007 0,0178
12	0,437 11,099	0/–0,005 0/–0,127	0/–0,0025 0/–0,0635	0,919 23,342	0,015 0,381	0,032 0,813	0,13 59	0,0010 0,0254	0,0005 0,0127	0,0016 0,0406	0,0008 0,0203	0,0010 0,0254	0,0007 0,0178
16	0,500 12,700	0/–0,005 0/–0,127	0/–0,0025 0/–0,0635	1,241 31,521	0,015 0,381	0,032 0,813	0,22 100	0,0010 0,0254	0,0005 0,0127	0,0016 0,0406	0,0008 0,0203	0,0010 0,0254	0,0007 0,0178
20	0,500 12,700	0/–0,005 0/–0,127	0/–0,0025 0/–0,0635	1,478 37,541	0,015 0,381	0,032 0,813	0,26 118	0,0010 0,0254	0,0005 0,0127	0,0016 0,0406	0,0008 0,0203	0,0010 0,0254	0,0007 0,0178



Designation system

Examples: ZWMKP10ASK2CP55RP01
 KP 8AP

Material and surface treatment

No code Cadmium plated bearing steel
W¹⁾ Corrosion-resistant steel
S Zinc-nickel plated bearing steel
ZW¹⁾ Cadmium plated corrosion-resistant steel
SZW¹⁾ Zinc-nickel plated corrosion-resistant steel

Tolerances

No code Standard tolerances
M¹⁾ Reduced clearance and SKF super precision

Basic designation

Bore code (multiples of 1/16th inch)

Variation

	Lubricant	Version	Radial clearance	
			KP..	MKP.. ¹⁾
SK2	G354	Sealed	Standard	Reduced
S281	G395	Sealed	Standard	Reduced
S281-R	G395	Sealed	Reduced	–
SK2-R	G354	Sealed	Reduced	–
P¹⁾	G354	Shielded	Standard	Reduced
PG81¹⁾	G395	Shielded	Standard	Reduced
PG81-R¹⁾	G395	Shielded	Reduced	–
P-R¹⁾	G354	Shielded	Reduced	–

Passivation

No code Not treated
CP55²⁾ Passivated corrosion-resistant steel

Oversize

No code Standard outer diameter size
RP01¹⁾ 0.010 in/0,254 mm oversized outer diameter
RP02¹⁾ 0.020 in/0,508 mm oversized outer diameter

1) SKF option

2) SKF option, available only for corrosion-resistant steel material without other surface treatment

Tolerances cont., loads, clearance and torque

Nominal bore code	Tolerances		Static limit loads		Radial dynamic load rating ³⁾⁴⁾		Radial clearance		Maximum starting torque ⁵⁾	
	Sea max	SKF super precision	Radial C _s	Axial C _a	Load fixed with respect to outer ring	respect to inner ring	Standard	Reduced	Shielded	Sealed
–	in/mm	–	lbf/kN	–	lbf/kN	–	in/mm	–	oz-in/mNm	–
10	0.0016	0.0010	6 700	3 000	4 980	4 360	0.0004/ 0.0010	0.0002/ 0.0005	2	3
	0,0406	0,0254	29,80	13,35	22,15	19,39	0,0101/ 0,0254	0,0051/ 0,0127	14.12	21,18
12	0.0016	0.0010	8 790	3 900	5 980	5 320	0.0004/ 0.0010	0.0002/ 0.0005	2	3
	0,0406	0,0254	39,10	17,35	26,60	23,66	0,0101/ 0,0254	0,0051/ 0,0127	14.12	21,18
16	0.0016	0.0010	11 900	5 200	7 070	6 400	0.0004/ 0.0010	0.0002/ 0.0005	2.67	4
	0,0406	0,0254	52,93	23,13	31,45	28,47	0,0101/ 0,0254	0,0051/ 0,0127	18.83	28.25
20	0.0016	0.0010	13 800	6 100	7 400	6 810	0.0004/ 0.0010	0.0002/ 0.0005	3.33	5
	0,0406	0,0254	61,39	27,13	32,92	30,29	0,0101/ 0,0254	0,0051/ 0,0127	23.53	35.31

3) For average life of 10 000 cycles at $\theta = 90^\circ$ oscillation, see page 38

4) If G395 load rating is 20% lower

5) Values are valid for bearings with G395. When using G354, values are 20% higher

1.16 Deep groove ball bearing single row (inch dimensions)

KP..B bore code 16 to 37

Technical specification	AS 7949
Product standard	AS 27642

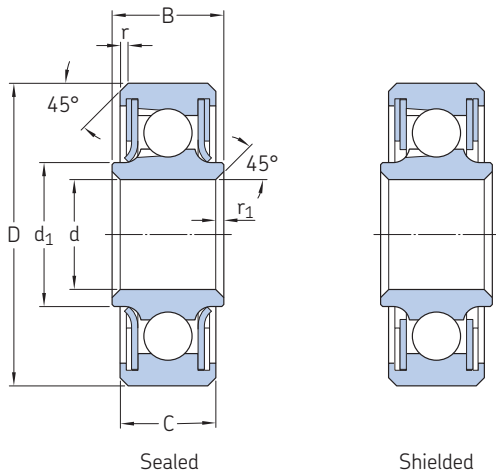

Dimensions

Nominal Dimensions

bore code	d	Δd_{mp}		Δd_s		D	ΔD_{mp}		ΔD_s	
		Standard	Precision	Standard	Precision		Standard	Precision		
in/mm										
16	1.0000 25,400	0/-0.0005 0/-0,0127	0/-0.0005 0/-0,0127	+0.0002/-0.0007 +0,0051/-0,0178	+0.0003/-0.0008 +0,0076/-0,0203	1.7500 44,450	0/-0.0010 0/-0,0254	0/-0.0010 0/-0,0254	+0.0010/-0.0020 +0,0254/-0,0508	
21	1.3130 33,350	0/-0.0010 0/-0,0254	-0.0005/-0.0010 -0,0127/-0,0254	+0.0008/-0.0008 +0,0203/-0,0203	+0.0003/-0.0008 +0,0076/-0,0203	2.0625 52,387	0/-0.0010 0/-0,0254	0/-0.0010 0/-0,0254	+0.0010/-0.0020 +0,0254/-0,0508	
23	1.4380 36,525	0/-0.0010 0/-0,0254	-0.0005/-0.0010 -0,0127/-0,0254	+0.0008/-0.0008 +0,0203/-0,0203	+0.0003/-0.0008 +0,0076/-0,0203	2.1875 55,562	0/-0.0010 0/-0,0254	0/-0.0010 0/-0,0254	+0.0010/-0.0020 +0,0254/-0,0508	
25	1.5630 39,700	0/-0.0010 0/-0,0254	-0.0005/-0.0010 -0,0127/-0,0254	+0.0008/-0.0008 +0,0203/-0,0203	+0.0003/-0.0008 +0,0076/-0,0203	2.3125 58,737	0/-0.0010 0/-0,0254	0/-0.0010 0/-0,0254	+0.0010/-0.0020 +0,0254/-0,0508	
29	1.8130 46,050	0/-0.0010 0/-0,0254	-0.0005/-0.0010 -0,0127/-0,0254	+0.0008/-0.0008 +0,0203/-0,0203	+0.0003/-0.0008 +0,0076/-0,0203	2.5625 65,087	0/-0.0010 0/-0,0254	0/-0.0010 0/-0,0254	+0.0010/-0.0020 +0,0254/-0,0508	
33	2.0630 52,400	0/-0.0010 0/-0,0254	-0.0005/-0.0010 -0,0127/-0,0254	+0.0008/-0.0008 +0,0203/-0,0203	+0.0003/-0.0008 +0,0076/-0,0203	2.8125 71,437	0/-0.0010 0/-0,0254	0/-0.0010 0/-0,0254	+0.0010/-0.0020 +0,0254/-0,0508	
37	2.3130 58,750	0/-0.0010 0/-0,0254	-0.0005/-0.0010 -0,0127/-0,0254	+0.0008/-0.0008 +0,0203/-0,0203	+0.0003/-0.0008 +0,0076/-0,0203	3.0625 77,787	0/-0.0010 0/-0,0254	0/-0.0010 0/-0,0254	+0.0010/-0.0020 +0,0254/-0,0508	

Dimensions cont. and tolerances

bore code	C	ΔC_s		B	ΔB_s		d_1	r_1	r	Mass \approx	Tolerances							
		Standard	Precision		Standard	Precision					Kia max	Precision	Kea max	Precision				
in/mm											lb/g				in/mm			
16	0.375 9,525	0/-0.005 0/-0,127	0/-0.005 0/-0,127	0.437 11,099	0/-0.005 0/-0,127	0/-0.0025 0/-0,0635	1.141 28,981	0.0240 0,610	0.0240 0,610	0.14 64	0.0010 0,0254	0.0008 0,0203	0.0016 0,0406	0.0008 0,0203				
21	0.375 9,525	0/-0.005 0/-0,127	0/-0.005 0/-0,127	0.437 11,099	0/-0.005 0/-0,127	0/-0.0025 0/-0,0635	1.454 36,931	0.0240 0,610	0.0240 0,610	0.16 73	0.0010 0,0254	0.0008 0,0203	0.0016 0,0406	0.0008 0,0203				
23	0.375 9,525	0/-0.005 0/-0,127	0/-0.005 0/-0,127	0.437 11,099	0/-0.005 0/-0,127	0/-0.0025 0/-0,0635	1.574 39,979	0.0240 0,610	0.0240 0,610	0.17 77	0.0010 0,0254	0.0008 0,0203	0.0016 0,0406	0.0008 0,0203				
25	0.375 9,525	0/-0.005 0/-0,127	0/-0.005 0/-0,127	0.437 11,099	0/-0.005 0/-0,127	0/-0.0025 0/-0,0635	1.693 43,002	0.0240 0,838	0.0240 0,838	0.19 86	0.0010 0,0254	0.0008 0,0203	0.0016 0,0406	0.0008 0,0203				
29	0.375 9,525	0/-0.005 0/-0,127	0/-0.005 0/-0,127	0.437 11,099	0/-0.005 0/-0,127	0/-0.0025 0/-0,0635	1.931 49,047	0.0240 0,610	0.0240 0,610	0.21 95	0.0010 0,0254	0.0008 0,0203	0.0016 0,0406	0.0008 0,0203				
33	0.375 9,525	0/-0.005 0/-0,127	0/-0.005 0/-0,127	0.437 11,099	0/-0.005 0/-0,127	0/-0.0025 0/-0,0635	2.231 56,667	0.0240 0,610	0.0240 0,610	0.23 104	0.0010 0,0254	0.0008 0,0203	0.0016 0,0406	0.0008 0,0203				
37	0.375 9,525	0/-0.005 0/-0,127	0/-0.005 0/-0,127	0.437 11,099	0/-0.005 0/-0,127	0/-0.0025 0/-0,0635	2.468 62,687	0.0240 0,610	0.0240 0,610	0.26 118	0.0010 0,0254	0.0008 0,0203	0.0016 0,0406	0.0008 0,0203				



Designation system

Examples: ZWMKP16BSK2CP55RP01
 KP37BP

Material and surface treatment

No code Cadmium plated bearing steel
W¹⁾ Corrosion-resistant steel
S Zinc-nickel plated bearing steel
ZW¹⁾ Cadmium plated corrosion-resistant steel
SZW¹⁾ Zinc-nickel plated corrosion-resistant steel

Tolerances

No code Standard tolerances
M Reduced clearance and precision

Basic designation

Bore code (multiples of 1/16th inch)

Variation

	Lubricant	Version	Radial clearance	
			KP..	MKP..
SK2	G354	Sealed	Standard	Reduced
S281	G395	Sealed	Standard	Reduced
S281-R¹⁾	G395	Sealed	Reduced	–
SK2-R¹⁾	G354	Sealed	Reduced	–
P¹⁾	G354	Shielded	Standard	Reduced
PG81¹⁾	G395	Shielded	Standard	Reduced
PG81-R¹⁾	G395	Shielded	Reduced	–
P-R¹⁾	G354	Shielded	Reduced	–

Passivation

No code Not treated
CP55²⁾ Passivated corrosion-resistant steel

Oversize

No code Standard outer diameter size
RP01¹⁾ 0.010 in/0,254 mm oversized outer diameter
RP02¹⁾ 0.020 in/0,508 mm oversized outer diameter

1) SKF option

2) SKF option, available only for corrosion-resistant steel material without other surface treatment

Tolerances cont., loads, clearance and torque

Nominal bore code	Tolerances				Static limit loads		Radial dynamic load rating ³⁾⁴⁾		Radial clearance		Maximum starting torque ⁵⁾	
	Sia max Standard	Precision	Sea max Standard	Precision	Radial C _s	Axial C _a	Load fixed with respect to outer ring	Load fixed with respect to inner ring	Standard	Reduced	Shielded	Sealed
–	in/mm				lbf/kN		lbf/kN		in/mm		oz-in/mNm	
16	0.0010 0,0254	0.0008 0,0203	0.0016 0,0406	0.0010 0,0254	8 090 35,99	3 600 16,01	4 260 18,95	3 960 17,61	0.0003/0.0010 0,0076/0,0254	0.0001/0.0005 0,0025/0,0127	3.33 23,53	5 35,3
21	0.0010 0,0254	0.0008 0,0203	0.0016 0,0406	0.0010 0,0254	9 840 43,77	4 400 19,57	4 590 20,42	4 290 19,08	0.0003/0.0010 0,0076/0,0254	0.0001/0.0005 0,0025/0,0127	4.67 32,95	7 49,42
23	0.0010 0,0254	0.0008 0,0203	0.0016 0,0406	0.0010 0,0254	10 500 46,71	4 700 20,91	4 650 20,68	4 360 19,39	0.0003/0.0010 0,0076/0,0254	0.0001/0.0005 0,0025/0,0127	5.33 37,65	9 63,54
25	0.0010 0,0254	0.0008 0,0203	0.0016 0,0406	0.0010 0,0254	11 300 50,27	5 000 22,24	4 680 20,82	4 420 19,66	0.0003/0.0010 0,0076/0,0254	0.0001/0.0005 0,0025/0,0127	6 42,36	9 63,54
29	0.0010 0,0254	0.0008 0,0203	0.0016 0,0406	0.0010 0,0254	12 700 56,49	5 600 24,91	4 760 21,17	4 530 20,15	0.0003/0.0010 0,0076/0,0254	0.0001/0.0005 0,0025/0,0127	8 56,48	14 98,84
33	0.0010 0,0254	0.0008 0,0203	0.0016 0,0406	0.0010 0,0254	14 400 64,05	6 400 28,47	4 820 21,44	4 630 20,60	0.0003/0.0010 0,0076/0,0254	0.0001/0.0005 0,0025/0,0127	9.33 65,89	14 98,84
37	0.0010 0,0254	0.0008 0,0203	0.0016 0,0406	0.0010 0,0254	15 800 70,28	7 000 31,14	4 880 21,71	4 690 20,86	0.0003/0.0010 0,0076/0,0254	0.0001/0.0005 0,0025/0,0127	11.33 80,01	20 141,23

3) For average life of 10 000 cycles at $\theta = 90^\circ$ oscillation, see page 38

4) If G395 load rating is 20% lower

5) Values are valid for bearings with G395. When using G354, values are 20% higher

1.16 Deep groove ball bearing single row (inch dimensions)

KP..B bore code 47 to 68

Technical specification	AS 7949
Product standard	AS 27642

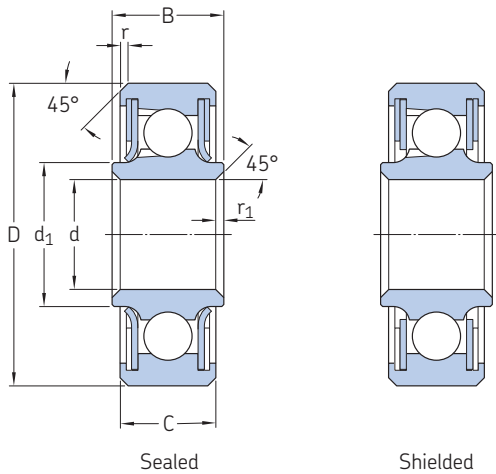

Dimensions

Nominal Dimensions

bore code	d	Δd_{mp}		Δd_s		D	ΔD_{mp}		ΔD_s
		Standard	Precision	Standard	Precision		Standard	Precision	
in/mm									
47	2.9380 74,625	0/-0.0010 0/-0,0254	-0.0005/-0.0010 -0,0127/-0,0254	+0.0008/-0.0008 +0,0203/-0,0203	+0.0003/-0.0008 +0,0076/-0,0203	3.8750 98,425	0/-0.0010 0/-0,0254	0/-0.0010 0/-0,0254	+0.0010/-0.0020 +0,0254/-0,0508
49	3.0630 77,800	0/-0.0010 0/-0,0254	-0.0005/-0.0010 -0,0127/-0,0254	+0.0008/-0.0008 +0,0203/-0,0203	+0.0003/-0.0008 +0,0076/-0,0203	4.0000 101,600	0/-0.0010 0/-0,0254	0/-0.0010 0/-0,0254	+0.0010/-0.0020 +0,0254/-0,0508
52	3.2500 82,550	0/-0.0010 0/-0,0254	0/-0.0010 0/-0,0254	+0.0005/-0.0015 +0,0127/-0,0381	+0.0003/-0.0013 +0,0076/-0,0330	4.1875 106,363	0/-0.0010 0/-0,0254	0/-0.0010 0/-0,0254	+0.0010/-0.0020 +0,0254/-0,0508
56	3.5000 88,900	0/-0.0010 0/-0,0254	0/-0.0010 0/-0,0254	+0.0005/-0.0015 +0,0127/-0,0381	+0.0003/-0.0013 +0,0076/-0,0330	4.4375 112,713	0/-0.0010 0/-0,0254	0/-0.0010 0/-0,0254	+0.0010/-0.0020 +0,0254/-0,0508
60	3.7500 95,250	0/-0.0010 0/-0,0254	0/-0.0010 0/-0,0254	+0.0005/-0.0015 +0,0127/-0,0381	+0.0003/-0.0013 +0,0076/-0,0330	4.6875 119,063	0/-0.0010 0/-0,0254	0/-0.0010 0/-0,0254	+0.0010/-0.0020 +0,0254/-0,0508
64	4.0000 101,600	0/-0.0010 0/-0,0254	0/-0.0010 0/-0,0254	+0.0005/-0.0015 +0,0127/-0,0381	+0.0003/-0.0013 +0,0076/-0,0330	4.9375 125,413	0/-0.0010 0/-0,0254	0/-0.0010 0/-0,0254	+0.0010/-0.0020 +0,0254/-0,0508
68	4.2500 107,950	0/-0.0010 0/-0,0254	0/-0.0010 0/-0,0254	+0.0005/-0.0015 +0,0127/-0,0381	+0.0003/-0.0013 +0,0076/-0,0330	5.3125 134,938	0/-0.0010 0/-0,0254	0/-0.0010 0/-0,0254	+0.0010/-0.0020 +0,0254/-0,0508

Dimensions cont. and tolerances

bore code	C	ΔC_s		B	ΔB_s		d_1	r_1	r	Mass ≈	Tolerances			
		Standard	Precision		Standard	Precision					Kia max Standard	Precision	Kea max Standard	Precision
in/mm														
47	0.469 11,912	0/-0.005 0/-0,127	0/-0.005 0/-0,127	0.531 13,487	0/-0.005 0/-0,127	0/-0.0025 0/-0,0635	3.093 78,562	0.039 0,991	0.039 0,991	0.49 222	0.0010 0,0254	0.0008 0,0203	0.0016 0,0406	0.0008 0,0203
49	0.469 11,913	0/-0.005 0/-0,127	0/-0.005 0/-0,127	0.531 13,487	0/-0.005 0/-0,127	0/-0.0025 0/-0,0635	3.222 81,838	0.039 0,991	0.039 0,991	0.53 240	0.0010 0,0254	0.0008 0,0203	0.0016 0,0406	0.0008 0,0203
52	0.469 11,913	0/-0.005 0/-0,127	0/-0.005 0/-0,127	0.531 13,487	0/-0.005 0/-0,127	0/-0.005 0/-0,127	3.479 88,367	0.039 0,991	0.039 0,991	0.55 249	0.0012 0,0305	0.0012 0,0305	0.0016 0,0406	0.0016 0,0406
56	0.469 11,913	0/-0.005 0/-0,127	0/-0.005 0/-0,127	0.531 13,487	0/-0.005 0/-0,127	0/-0.005 0/-0,127	3.775 95,885	0.039 0,991	0.039 0,991	0.58 263	0.0012 0,0305	0.0012 0,0305	0.0016 0,0406	0.0016 0,0406
60	0.469 11,913	0/-0.005 0/-0,127	0/-0.005 0/-0,127	0.531 13,487	0/-0.005 0/-0,127	0/-0.005 0/-0,127	4.014 101,956	0.039 0,991	0.039 0,991	0.61 277	0.0012 0,0305	0.0012 0,0305	0.0016 0,0406	0.0016 0,0406
64	0.469 11,913	0/-0.005 0/-0,127	0/-0.005 0/-0,127	0.531 13,487	0/-0.005 0/-0,127	0/-0.005 0/-0,127	4.253 108,026	0.039 0,991	0.039 0,991	0.64 290	0.0012 0,0305	0.0012 0,0305	0.0016 0,0406	0.0016 0,0406
68	0.531 13,487	0/-0.005 0/-0,127	0/-0.005 0/-0,127	0.593 15,062	0/-0.005 0/-0,127	0/-0.005 0/-0,127	4.517 114,732	0.039 0,991	0.039 0,991	0.73 331	0.0012 0,0305	0.0012 0,0305	0.0016 0,0406	0.0016 0,0406



Designation system

Examples: ZWMKP16BSK2CP55RP01
 KP37BP

Material and surface treatment

No code Cadmium plated bearing steel
W¹⁾ Corrosion-resistant steel
S Zinc-nickel plated bearing steel
ZW¹⁾ Cadmium plated corrosion-resistant steel
SZW¹⁾ Zinc-nickel plated corrosion-resistant steel

Tolerances

No code Standard tolerances
M Reduced clearance and precision

Basic designation

Bore code (multiples of 1/16th inch)

Variation

	Lubricant	Version	Radial clearance	
			KP..	MKP..
SK2	G354	Sealed	Standard	Reduced
S281	G395	Sealed	Standard	Reduced
S281-R¹⁾	G395	Sealed	Reduced	–
SK2-R¹⁾	G354	Sealed	Reduced	–
P¹⁾	G354	Shielded	Standard	Reduced
PG81¹⁾	G395	Shielded	Standard	Reduced
PG81-R¹⁾	G395	Shielded	Reduced	–
P-R¹⁾	G354	Shielded	Reduced	–

Passivation

No code Not treated
CP55²⁾ Passivated corrosion-resistant steel

Oversize

No code Standard outer diameter size
RP01¹⁾ 0.010 in/0,254 mm oversized outer diameter
RP02¹⁾ 0.020 in/0,508 mm oversized outer diameter

1) SKF option

2) SKF option, available only for corrosion-resistant steel material without other surface treatment

Tolerances cont., loads, clearance and torque

Nominal bore code	Tolerances				Static limit loads		Radial dynamic load rating ³⁾⁴⁾		Radial clearance		Maximum starting torque ⁵⁾	
	Sia max Standard	Sea max Precision	Standard	Precision	Radial C _s	Axial C _a	Load fixed with respect to outer ring	Load fixed with respect to inner ring	Standard	Reduced	Shielded	Sealed
–	in/mm				lbf/kN				in/mm		oz-in/mNm	
47	0,0010 0,0254	0,0008 0,0203	0,0016 0,0406	0,0010 0,0254	24 700 109,87	10 900 48,49	6 600 29,36	6 390 28,42	0,0003/0,0010 0,0076/0,0254	0,0001/0,0005 0,0025/0,0127	16 112,96	30 211,85
49	0,0010 0,0254	0,0008 0,0203	0,0016 0,0406	0,0010 0,0254	27 500 122,33	12 100 53,82	8 150 36,25	7 840 34,87	0,0003/0,0010 0,0076/0,0254	0,0001/0,0005 0,0025/0,0127	16,67 117,67	32 225,97
52	0,0010 0,0254	0,0010 0,0254	0,0016 0,0406	0,0016 0,0406	28 700 127,66	12 600 56,05	8 210 36,52	7 880 35,05	0,0003/0,0015 0,0076/0,0381	0,0001/0,0005 0,0025/0,0127		
56	0,0010 0,0254	0,0010 0,0254	0,0016 0,0406	0,0016 0,0406	31 200 138,78	13 700 60,94	8 240 36,65	7 970 35,45	0,0003/0,0015 0,0076/0,0381	0,0001/0,0005 0,0025/0,0127		
60	0,0010 0,0254	0,0010 0,0254	0,0016 0,0406	0,0016 0,0406	33 100 147,24	14 600 64,94	8 290 36,88	8 010 35,63	0,0003/0,0015 0,0076/0,0381	0,0001/0,0005 0,0025/0,0127		
64	0,0010 0,0254	0,0010 0,0254	0,0016 0,0406	0,0016 0,0406	35 000 155,69	15 400 68,50	8 350 37,14	8 100 36,03	0,0003/0,0015 0,0076/0,0381	0,0001/0,0005 0,0025/0,0127		
68	0,0010 0,0254	0,0010 0,0254	0,0016 0,0406	0,0016 0,0406	41 900 186,38	18 400 81,85	10 280 45,73	9 900 44,04	0,0003/0,0015 0,0076/0,0381	0,0001/0,0005 0,0025/0,0127		

3) For average life of 10 000 cycles at $\theta = 90^\circ$ oscillation, see page 38

4) If G395 load rating is 20% lower

5) Values are valid for bearings with G395. When using G354, values are 20% higher

1.16 Deep groove ball bearing single row (inch dimensions)

KP.. B bore code 72 to 96

Technical specification	AS 7949
Product standard	AS 27642

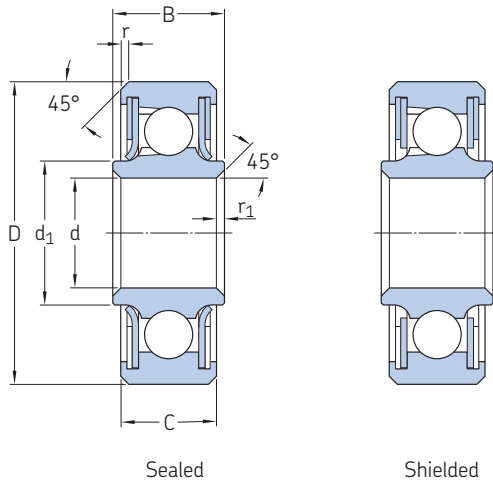

1.16

Dimensions

Nominal bore code	Dimensions		Precision	Δds		D	ΔDmp		Precision	ΔDs
	d	Δdmp Standard		Standard	Precision		Standard	Precision		
– in/mm										
72	4.5000 114,300	0/-0.0010 0/-0,0254	0/-0.0010 0/-0,0254	+0.0005/-0.0015 +0,0127/-0,0381	+0.0003/-0.0013 +0,0076/-0,0330	5.5625 141,288	0/-0.0010 0/-0,0254	0/-0.0010 0/-0,0254	+0.0010/-0.0020 +0,0254/-0,0508	
76	4.7500 120,650	0/-0.0010 0/-0,0254	0/-0.0010 0/-0,0254	+0.0005/-0.0015 +0,0127/-0,0381	+0.0003/-0.0013 +0,0076/-0,0330	5.8125 147,638	0/-0.0010 0/-0,0254	0/-0.0010 0/-0,0254	+0.0010/-0.0020 +0,0254/-0,0508	
80	5.0000 127,000	0/-0.0010 0/-0,0254	0/-0.0010 0/-0,0254	+0.0005/-0.0015 +0,0127/-0,0381	+0.0003/-0.0013 +0,0076/-0,0330	6.0625 153,988	0/-0.0010 0/-0,0254	0/-0.0010 0/-0,0254	+0.0010/-0.0020 +0,0254/-0,0508	
84	5.2500 133,350	0/-0.0010 0/-0,0254	0/-0.0010 0/-0,0254	+0.0005/-0.0015 +0,0127/-0,0381	+0.0003/-0.0013 +0,0076/-0,0330	6.3125 160,338	0/-0.0010 0/-0,0254	0/-0.0010 0/-0,0254	+0.0010/-0.0020 +0,0254/-0,0508	
88	5.5000 139,700	0/-0.0010 0/-0,0254	0/-0.0010 0/-0,0254	+0.0005/-0.0015 +0,0127/-0,0381	+0.0003/-0.0013 +0,0076/-0,0330	6.5625 166,687	0/-0.0010 0/-0,0254	0/-0.0010 0/-0,0254	+0.0010/-0.0020 +0,0254/-0,0508	
92	5.7500 146,050	0/-0.0010 0/-0,0254	0/-0.0010 0/-0,0254	+0.0005/-0.0015 +0,0127/-0,0381	+0.0003/-0.0013 +0,0076/-0,0330	6.8125 173,037	0/-0.0010 0/-0,0254	0/-0.0010 0/-0,0254	+0.0010/-0.0020 +0,0254/-0,0508	
96	6.0000 152,400	0/-0.0010 0/-0,0254	0/-0.0010 0/-0,0254	+0.0005/-0.0015 +0,0127/-0,0381	+0.0003/-0.0013 +0,0076/-0,0330	7.0625 179,387	0/-0.0010 0/-0,0254	0/-0.0010 0/-0,0254	+0.0010/-0.0020 +0,0254/-0,0508	

Dimensions cont. and tolerances

Nominal bore code	Dimensions		B	ΔBs		d1	r1	r	Mass ≈	Tolerances			
	C	ΔCs		Standard	Precision					Standard	Precision	Kia max Standard	Precision
– in/mm													
72	0.531 13,487	0/-0.005 0/-0,127	0.593 15,062	0/-0.005 0/-0,127	0/-0.005 0/-0,127	4.774 121,260	0.039 0,991	0.039 0,991	0.76 345	0.0012 0,0305	0.0012 0,0305	0.0016 0,0406	0.0016 0,0406
76	0.531 13,487	0/-0.005 0/-0,127	0.593 15,062	0/-0.005 0/-0,127	0/-0.005 0/-0,127	5.046 128,168	0.039 0,991	0.039 0,991	1.00 454	0.0014 0,0356	0.0014 0,0356	0.0018 0,0457	0.0018 0,0457
80	0.531 13,487	0/-0.005 0/-0,127	0.593 15,062	0/-0.005 0/-0,127	0/-0.005 0/-0,127	5.246 133,248	0.039 0,991	0.039 0,991	1.04 472	0.0014 0,0356	0.0014 0,0356	0.0018 0,0457	0.0018 0,0457
84	0.531 13,487	0/-0.005 0/-0,127	0.593 15,062	0/-0.005 0/-0,127	0/-0.005 0/-0,127	5.506 139,852	0.039 0,991	0.039 0,991	1.09 494	0.0014 0,0356	0.0014 0,0356	0.0018 0,0457	0.0018 0,0457
88	0.531 13,487	0/-0.005 0/-0,127	0.593 15,062	0/-0.005 0/-0,127	0/-0.005 0/-0,127	5.770 146,558	0.039 0,991	0.039 0,991	1.14 517	0.0014 0,0356	0.0014 0,0356	0.0018 0,0457	0.0018 0,0457
92	0.531 13,487	0/-0.005 0/-0,127	0.593 15,062	0/-0.005 0/-0,127	0/-0.005 0/-0,127	6.033 153,238	0.039 0,991	0.039 0,991	1.18 535	0.0014 0,0356	0.0014 0,0356	0.0018 0,0457	0.0018 0,0457
96	0.531 13,487	0/-0.005 0/-0,127	0.593 15,062	0/-0.005 0/-0,127	0/-0.005 0/-0,127	6.303 160,096	0.039 0,991	0.039 0,991	1.23 558	0.0014 0,0356	0.0014 0,0356	0.0020 0,0508	0.0020 0,0508



Designation system

Examples: ZWMKP16BSK2CP55RP01
 KP37BP

Material and surface treatment

No code Cadmium plated bearing steel
W¹⁾ Corrosion-resistant steel
S Zinc-nickel plated bearing steel
ZW¹⁾ Cadmium plated corrosion-resistant steel
SZW¹⁾ Zinc-nickel plated corrosion-resistant steel

Tolerances

No code Standard tolerances
M Reduced clearance and precision

Basic designation

Bore code (multiples of 1/16th inch)

Variation

	Lubricant	Version	Radial clearance	
			KP..	MKP..
SK2	G354	Sealed	Standard	Reduced
S281	G395	Sealed	Standard	Reduced
S281-R¹⁾	G395	Sealed	Reduced	–
SK2-R¹⁾	G354	Sealed	Reduced	–
P¹⁾	G354	Shielded	Standard	Reduced
PG81¹⁾	G395	Shielded	Standard	Reduced
PG81-R¹⁾	G395	Shielded	Reduced	–
P-R¹⁾	G354	Shielded	Reduced	–

Passivation

No code Not treated
CP55²⁾ Passivated corrosion-resistant steel

Oversize

No code Standard outer diameter size
RP01¹⁾ 0.010 in/0,254 mm oversized outer diameter
RP02¹⁾ 0.020 in/0,508 mm oversized outer diameter

1) SKF option

2) SKF option, available only for corrosion-resistant steel material without other surface treatment

Tolerances cont., loads, clearance and torque

Nominal bore code	Tolerances				Static limit loads		Radial dynamic load rating ³⁾⁴⁾		Radial clearance		Maximum starting torque ⁵⁾	
	Sia max Standard	Precision	Sea max Standard	Precision	Radial C _s	Axial C _a	outer ring	inner ring	Standard	Reduced	Shielded	Sealed
–	in/mm				lbf/kN				in/mm		oz-in/mNm	
72	0.0010 0,0254	0.0010 0,0254	0.0016 0,0406	0.0016 0,0406	44 300 197,06	19 500 86,74	10 330 45,95	10 000 44,48	0.0003/0.0015 0,0076/0,0381	0.0001/0.0005 0,0025/0,0127		
76	0.0012 0,0305	0.0012 0,0305	0.0018 0,0457	0.0018 0,0457	46 700 207,73	20 500 91,19	10 350 46,04	10 050 44,70	0.0003/0.0015 0,0076/0,0381	0.0001/0.0005 0,0025/0,0127		
80	0.0012 0,0305	0.0012 0,0305	0.0018 0,0457	0.0018 0,0457	48 200 214,40	21 200 94,30	10 360 46,08	10 090 44,88	0.0003/0.0015 0,0076/0,0381	0.0001/0.0005 0,0025/0,0127		
84	0.0012 0,0305	0.0012 0,0305	0.0018 0,0457	0.0018 0,0457	50 600 225,08	22 300 99,20	10 420 46,35	10 120 45,02	0.0003/0.0015 0,0076/0,0381	0.0001/0.0005 0,0025/0,0127		
88	0.0012 0,0305	0.0012 0,0305	0.0018 0,0457	0.0018 0,0457	53 000 235,76	23 300 103,64	10 480 46,62	10 200 45,37	0.0003/0.0015 0,0076/0,0381	0.0001/0.0005 0,0025/0,0127		
92	0.0012 0,0305	0.0012 0,0305	0.0018 0,0457	0.0018 0,0457	55 400 246,43	24 400 108,54	10 550 46,93	10 240 45,55	0.0003/0.0015 0,0076/0,0381	0.0001/0.0005 0,0025/0,0127		
96	0.0016 0,0406	0.0016 0,0406	0.0020 0,0508	0.0020 0,0508	57 700 256,66	25 400 112,98	10 520 46,80	10 210 45,42	0.0003/0.0015 0,0076/0,0381	0.0001/0.0005 0,0025/0,0127		

3) For average life of 10 000 cycles at $\theta = 90^\circ$ oscillation, see page 38

4) If G395 load rating is 20% lower

5) Values are valid for bearings with G395. When using G354, values are 20% higher

1.17 Deep groove ball bearing single row (inch dimensions)

KP..SP., KP..A..SP., KP..L...SP..

Technical specification –
Product standard –

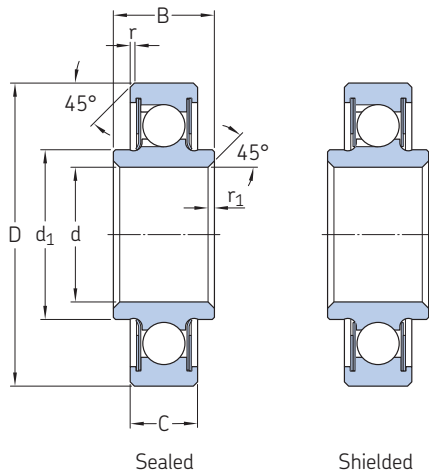

Dimensions, loads and clearance

Nominal bore code	Dimensions							Mass ≈	Static limit loads		Radial clearance
	d	D	C	B	d ₁	r ₁	r		Radial C _s	Axial C _a	
	+0.0002/-0.0003 +0,005/-0,008	-0.0003/-0.0008 -0,008/-0,020	0/-0.005 0/-0,127	0/-0.005 0/-0,127	≈	Min	Min				
	in/mm							lb/g	lbf/kN	in/mm	
3L..SP1	0.1898 4,821	0.6250 15,875	0.2031 5,159	0.2500 6,350	0.282 7,163	0.016 0,406	0.016 0,406	0.011 5	1 560 6,94	700 3,11	0.0001/0.0005 0,0025/0,0127
4A..SP3	0.2500 6,350	0.7500 19,050	0.2188 5,558	0.3125 7,938	0.356 9,042	0.025 0,635	0.016 0,406	0.022 10	1 870 8,32	840 3,74	0.0001/0.0005 0,0025/0,0127
4A..SP4	0.2500 6,350	0.7500 19,050	0.2188 5,558	0.4375 11,113	0.356 9,042	0.025 0,635	0.016 0,406	0.024 11	1 870 8,32	840 3,74	0.0001/0.0005 0,0025/0,0127
4A..SP5	0.2498 6,345	0.7503 19,058	0.2190 5,563	0.2810 7,137	0.346 8,788	0.015 0,381	0.015 0,381	0.018 8	1 870 8,32	840 3,74	0.0001/0.0005 0,0025/0,0127
4..SP4	0.2498 6,345	0.9017 22,903	0.3350 8,509	0.4840 12,294	0.431 10,947	0.040 1,016	0.030 0,762	0.042 19	2 930 13,03	1 310 5,83	0.0001/0.0005 0,0025/0,0127
6A..SP7	0.3750 9,525	0.8750 22,225	0.2188 5,558	0.3125 7,938	0.481 12,217	0.030 0,762	0.016 0,406	0.026 12	2 500 11,12	1 120 4,98	0.0001/0.0005 0,0025/0,0127
6A..SP8	0.3750 9,525	0.8750 22,225	0.2188 5,558	0.4375 11,113	0.481 12,217	0.025 0,635	0.016 0,406	0.029 13	2 500 11,12	1 120 4,98	0.0001/0.0005 0,0025/0,0127
6A..SP11	0.3750 9,525	0.8750 22,225	0.2188 5,558	0.5000 12,700	0.481 12,217	0.025 0,635	0.016 0,406	0.031 14	2 500 11,12	1 120 4,98	0.0001/0.0005 0,0025/0,0127
8A..SP2	0.5000 12,700	1.1250 28,575	0.2500 6,350	0.3750 9,525	0.640 16,256	0.035 0,889	0.015 0,381	0.053 24	3 900 17,35	1 740 7,74	0.0001/0.0007 0,0025/0,0178
8..SP2	0.4998 12,695	1.6878 42,870	0.5000 12,700	0.6200 15,748	0.750 19,050	0.035 0,889	0.035 0,889	0.218 99	11 800 52,49	5 270 23,44	0.0001/0.0007 0,0025/0,0178
10A..SP6	0.6250 15,875	1.3750 34,925	0.2813 7,145	0.4063 10,320	0.810 20,574	0.033 0,838	0.031 0,787	0.088 40	5 970 26,56	2 670 11,88	0.0001/0.0007 0,0025/0,0178



Designation system

Examples: ZWKP 8APSP2G81CP55RP01
 KP 4SP4

Material and surface treatment

No code	Cadmium plated bearing steel
W	Corrosion-resistant steel
S	Zinc-nickel plated bearing steel
ZW	Cadmium plated corrosion-resistant steel
SZW	Zinc-nickel plated corrosion-resistant steel

Basic designation

Bore code (multiples of 1/16th inch)

Shield and seal

No code	Sealed
P	Shielded

Lubricant

No code	Grease G354
G81	Grease G395

Passivation

No code	Not treated
CP55 ¹⁾	Passivated corrosion-resistant steel

Oversize

No code	Standard outer diameter size
RP01	0.010 in/0,254 mm oversized outer diameter
RP02	0.020 in/0,508 mm oversized outer diameter

¹⁾ Available only for corrosion-resistant steel material without other surface treatment

1.18 Deep groove ball bearing single row (inch dimensions)

B500.. bore code 538 to 542

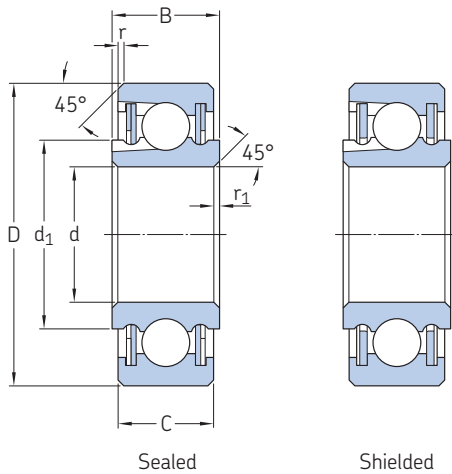

Technical specification AS 7949

Product standard

Standard tolerances: AS 27646
 Reduced clearance and precision: AS 21428

1.18



Dimensions

Nominal Dimensions

bore code	d	Δd_{mp} Standard	Precision	Δd_s Standard	D	ΔD_{mp} Standard	Precision	ΔD_s
in/mm								
538	0.6250 15,875	+0.0007/-0.0007 +0,0178/-0,0178	0/-0.0005 0/-0,0127	+0.0010/-0.0010 +0,0254/-0,0254	1.0625 26,987	0/-0.0010 0/-0,0254	0/-0.0005 0/-0,0127	+0.0005/-0.0015 +0,0127/-0,0381
539	0.7500 19,050	+0.0007/-0.0007 +0,0178/-0,0178	0/-0.0005 0/-0,0127	+0.0010/-0.0010 +0,0254/-0,0254	1.1875 30,163	0/-0.0010 0/-0,0254	0/-0.0005 0/-0,0127	+0.0005/-0.0015 +0,0127/-0,0381
540	0.8750 22,225	+0.0007/-0.0007 +0,0178/-0,0178	0/-0.0005 0/-0,0127	+0.0010/-0.0010 +0,0254/-0,0254	1.3125 33,338	0/-0.0010 0/-0,0254	0/-0.0005 0/-0,0127	+0.0005/-0.0015 +0,0127/-0,0381
541	1.0625 26,987	+0.0007/-0.0007 +0,0178/-0,0178	0/-0.0005 0/-0,0127	+0.0010/-0.0010 +0,0254/-0,0254	1.5000 38,100	0/-0.0010 0/-0,0254	0/-0.0005 0/-0,0127	+0.0005/-0.0015 +0,0127/-0,0381
542	1.3125 33,338	+0.0007/-0.0007 +0,0178/-0,0178	0/-0.0005 0/-0,0127	+0.0010/-0.0010 +0,0254/-0,0254	1.7500 44,450	0/-0.0010 0/-0,0254	0/-0.0005 0/-0,0127	+0.0005/-0.0015 +0,0127/-0,0381

Dimensions cont. and tolerances

bore code	Nominal Dimensions		B	ΔB_s		d_1	r_1	r	Mass	Tolerances				
	C	ΔC_s		Standard	Precision					Standard	Precision	Standard	Precision	Standard
in/mm											lb/g		in/mm	
538	0.250 6,350	0/-0.005 0/-0,127	0.281 7,137	0/-0.005 0/-0,127	0/-0.0025 0/-0,0635	0.777 19,736	0.015 0,381	0.015 0,381	0.03 14	0.0020 0,0508	0.0008 0,0203	0.0016 0,0406	0.0008 0,0203	
539	0.250 6,350	0/-0.005 0/-0,127	0.281 7,137	0/-0.005 0/-0,127	0/-0.0025 0/-0,0635	0.895 22,733	0.015 0,381	0.015 0,381	0.04 18	0.0020 0,0508	0.0008 0,0203	0.0016 0,0406	0.0008 0,0203	
540	0.250 6,350	0/-0.005 0/-0,127	0.281 7,137	0/-0.005 0/-0,127	0/-0.0025 0/-0,0635	1.016 25,806	0.015 0,381	0.015 0,381	0.05 23	0.0020 0,0508	0.0008 0,0203	0.0016 0,0406	0.0008 0,0203	
541	0.250 6,350	0/-0.005 0/-0,127	0.281 7,137	0/-0.005 0/-0,127	0/-0.0025 0/-0,0635	1.216 30,886	0.015 0,381	0.015 0,381	0.06 27	0.0020 0,0508	0.0008 0,0203	0.0016 0,0406	0.0008 0,0203	
542	0.250 6,350	0/-0.005 0/-0,127	0.281 7,137	0/-0.005 0/-0,127	0/-0.0025 0/-0,0635	1.451 36,855	0.015 0,381	0.015 0,381	0.09 41	0.0020 0,0508	0.0008 0,0203	0.0016 0,0406	0.0008 0,0203	



Designation system

Examples: ZWMB540DDSK2CP55RP01 B538P

Material and surface treatment

No code Cadmium plated bearing steel
W¹⁾ Corrosion-resistant steel
S Zinc-nickel plated bearing steel
ZW¹⁾ Cadmium plated corrosion-resistant steel
SZW¹⁾ Zinc-nickel plated corrosion-resistant steel

Tolerances and radial clearance

No code Standard clearance and tolerances
M Reduced clearance and precision

Basic designation

Bore code (multiples of 1/16th inch)

Variation

	Lubricant	Version
DDSK2	G354	Sealed
DDS281	G395	Sealed
PG81 ¹⁾	G395	Shielded
P ¹⁾	G354	Shielded

Passivation

No code Not treated
CP55²⁾ Passivated corrosion-resistant steel

Oversize

No code Standard outer diameter size
RP01¹⁾ 0.010 in/0,254 mm oversized outer diameter
RP02¹⁾ 0.020 in/0,508 mm oversized outer diameter

¹⁾ SKF option

²⁾ SKF option, available only for corrosion-resistant steel material without other surface treatment

Tolerances cont., loads, clearance and torque

Nominal bore code	Tolerances				Static limit loads		Radial dynamic load rating ³⁾⁴⁾		Radial clearance		Maximum starting torque ⁵⁾	
	Sia max Standard	Sea max Precision	Sea max Standard	Sea max Precision	Radial C _s	Axial C _a	outer ring	inner ring	Standard	Reduced	Shielded	Sealed
–	in/mm				lbf/kN				in/mm		oz-in/mNm	
538	0.0020 0,0508	0.0008 0,0203	0.0016 0,0406	0.0008 0,0203	3 280 14,60	1 500 6,67	1 990 8,85	1 820 8,10	0.0008/0.0018 0,0203/0,0457	0.0001/0.0005 0,0025/0,0127	1.33 9,41	2 14,12
539	0.0020 0,0508	0.0008 0,0203	0.0016 0,0406	0.0008 0,0203	3 750 16,68	1 700 7,56	2 050 9,12	1 900 8,45	0.0008/0.0018 0,0203/0,0457	0.0001/0.0005 0,0025/0,0127	1.33 9,41	2 14,12
540	0.0020 0,0508	0.0008 0,0203	0.0016 0,0406	0.0008 0,0203	4 220 18,77	1 900 8,45	2 110 9,39	1 970 8,76	0.0008/0.0018 0,0203/0,0457	0.0001/0.0005 0,0025/0,0127	2 14,12	3 21,18
541	0.0020 0,0508	0.0008 0,0203	0.0016 0,0406	0.0008 0,0203	5 000 22,24	2 200 9,79	2 170 9,65	2 020 8,99	0.0008/0.0018 0,0203/0,0457	0.0001/0.0005 0,0025/0,0127	2.67 18,83	4 28,25
542	0.0020 0,0508	0.0008 0,0203	0.0016 0,0406	0.0008 0,0203	5 950 26,47	2 700 12,01	2 220 9,88	2 130 9,47	0.0008/0.0018 0,0203/0,0457	0.0001/0.0005 0,0025/0,0127	2.67 18,83	4 28,25

³⁾ For average life of 10 000 cycles at $\theta = 90^\circ$ oscillation, see page 38

⁴⁾ If G395 load rating is 20% lower

⁵⁾ Values are valid for bearings with G395. When using G354, values are 20% higher

1.18 Deep groove ball bearing single row (inch dimensions)

B500.. bore code 543 to 546

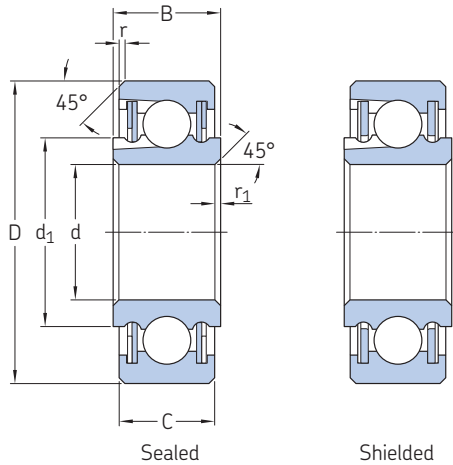

Technical specification AS 7949

Product standard
Standard tolerances: AS 27646
Reduced clearance and precision: AS 21428

Dimensions

Nominal Dimensions

bore code	d	Δd_{mp}		Δd_s	D	ΔD_{mp}		ΔD_s
		Standard	Precision			Standard	Precision	
– in/mm								
543	1.5625 39,687	+0.0007/-0.0007 +0,0178/-0,0178	0/-0.0005 0/-0,0127	+0.0010/-0.0010 +0,0254/-0,0254	2.0000 50,800	0/-0.0010 0/-0,0254	0/-0.0005 0/-0,0127	+0.0005/-0.0015 +0,0127/-0,0381
544	1.8125 46,037	+0.0010/-0.0010 +0,0254/-0,0254	0/-0.0008 0/-0,0203	+0.0016/-0.0016 +0,0406/-0,0406	2.2500 57,150	0/-0.0015 0/-0,0381	0/-0.0007 0/-0,0178	+0.0008/-0.0023 +0,0203/-0,0584
545	2.0625 52,387	+0.0010/-0.0010 +0,0254/-0,0254	0/-0.0008 0/-0,0203	+0.0016/-0.0016 +0,0406/-0,0406	2.6250 66,675	0/-0.0015 0/-0,0381	0/-0.0007 0/-0,0178	+0.0008/-0.0023 +0,0203/-0,0584
546	2.3125 58,737	+0.0010/-0.0010 +0,0254/-0,0254	0/-0.0008 0/-0,0203	+0.0016/-0.0016 +0,0406/-0,0406	2.8750 73,025	0/-0.0015 0/-0,0381	0/-0.0007 0/-0,0178	+0.0008/-0.0023 +0,0203/-0,0584

Dimensions cont. and tolerances

Nominal bore code	Dimensions				B	ΔB_s	d_1	r_1	r	Mass	Tolerances				
	C	ΔC_s	Standard	Precision							Standard	Precision	Standard	Precision	Standard
– in/mm												lb/g		in/mm	
543	0.250 6,350	0/-0.005 0/-0,127	0/-0.005 0/-0,127	0.281 7,137	0/-0.005 0/-0,127	0/-0.0025 0/-0,0635	1.702 43,231	0.015 0,381	0.015 0,381	0.10 45	0.0020 0,0508	0.0008 0,0203	0.0016 0,0406	0.0008 0,0203	
544	0.250 6,350	0/-0.005 0/-0,127	0/-0.005 0/-0,127	0.281 7,137	0/-0.005 0/-0,127	0/-0.0025 0/-0,0635	1.970 50,038	0.015 0,381	0.015 0,381	0.11 50	0.0020 0,0508	0.0008 0,0203	0.0016 0,0406	0.0008 0,0203	
545	0.250 6,350	0/-0.005 0/-0,127	0/-0.005 0/-0,127	0.281 7,137	0/-0.005 0/-0,127	0/-0.0025 0/-0,0635	2.286 58,064	0.015 0,381	0.015 0,381	0.15 68	0.0020 0,0508	0.0008 0,0203	0.0016 0,0406	0.0008 0,0203	
546	0.250 6,350	0/-0.005 0/-0,127	0/-0.005 0/-0,127	0.281 7,137	0/-0.005 0/-0,127	0/-0.0025 0/-0,0635	2.527 64,186	0.015 0,381	0.015 0,381	0.17 77	0.0020 0,0508	0.0008 0,0203	0.0016 0,0406	0.0008 0,0203	



Designation system

Examples: ZWMB540DDSK2CP55RP01 B538P

Material and surface treatment

No code Cadmium plated bearing steel
W¹⁾ Corrosion-resistant steel
S Zinc-nickel plated bearing steel
ZW¹⁾ Cadmium plated corrosion-resistant steel
SZW¹⁾ Zinc-nickel plated corrosion-resistant steel

Tolerances and radial clearance

No code Standard clearance and tolerances
M Reduced clearance and precision

Basic designation

Bore code (multiples of 1/16th inch)

Variation

	Lubricant	Version
DDSK2	G354	Sealed
DDSK281	G395	Sealed
PG81¹⁾	G395	Shielded
P¹⁾	G354	Shielded

Passivation

No code Not treated
CP55²⁾ Passivated corrosion-resistant steel

Oversize

No code Standard outer diameter size
RP01¹⁾ 0.010 in/0,254 mm oversized outer diameter
RP02¹⁾ 0.020 in/0,508 mm oversized outer diameter

¹⁾ SKF option

²⁾ SKF option, available only for corrosion-resistant steel material without other surface treatment

Tolerances cont., loads, clearance and torque

Nominal bore code	Tolerances				Static limit loads		Radial dynamic load rating ³⁾⁴⁾		Radial clearance		Maximum starting torque ⁵⁾	
	Sia max	Sea max	Standard	Precision	Radial C _s	Axial C _a	Outer ring	Inner ring	Standard	Reduced	Shielded	Sealed
–	in/mm				lbf/kN				in/mm		oz-in/mNm	
543	0.0020 0,0508	0.0008 0,0203	0.0016 0,0406	0.0008 0,0203	6 880 30,60	3 200 14,23	2 260 10,05	2 180 9,70	0.0008/0.0018 0,0203/0,0457	0.0001/0.0005 0,0025/0,0127	3.33 23,53	5 35,31
544	0.0020 0,0508	0.0008 0,0203	0.0016 0,0406	0.0008 0,0203	7 980 35,50	3 600 16,01	2 300 10,23	2 220 9,88	0.0008/0.0018 0,0203/0,0457	0.0001/0.0005 0,0025/0,0127	3.33 23,53	6 42,36
545	0.0020 0,0508	0.0008 0,0203	0.0016 0,0406	0.0008 0,0203	9 220 41,01	4 000 17,79	2 340 10,41	2 260 10,05	0.0008/0.0018 0,0203/0,0457	0.0001/0.0005 0,0025/0,0127	4 28,25	7 49,42
546	0.0020 0,0508	0.0008 0,0203	0.0016 0,0406	0.0008 0,0203	10 150 45,15	4 400 19,57	2 360 10,50	2 280 10,14	0.0008/0.0018 0,0203/0,0457	0.0001/0.0005 0,0025/0,0127	4 28,25	8 56,48

³⁾ For average life of 10 000 cycles at $\theta = 90^\circ$ oscillation, see page 38

⁴⁾ If G395 load rating is 20% lower

⁵⁾ Values are valid for bearings with G395. When using G354, values are 20% higher

1.19 Deep groove ball bearing double row (inch dimensions)
B5500..

Technical specification	-
Product standard	-

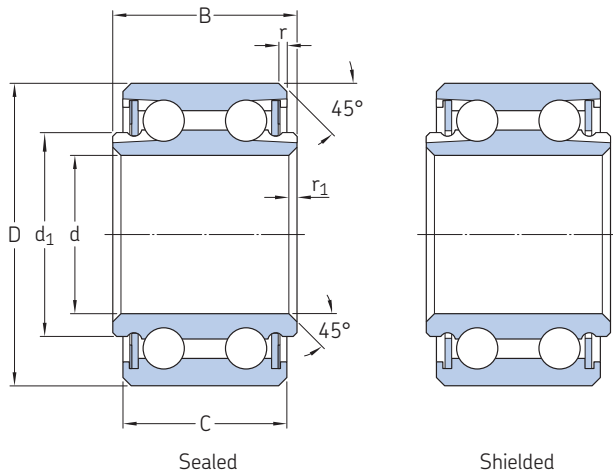

1.19

Dimensions

Nominal Dimensions

bore code	d	Δdmp	D	ΔDmp	C	ΔCs	B	ΔBs	d ₁ ≈	r ₁ +0,020/0 +0,508/0	r +0,020/0 +0,508/0
in/mm											
5538	0.6250 15,875	0/-0.0005 0/-0,0127	1.0625 26,987	0/-0.0005 0/-0,0127	0.500 12,700	0/-0.0005 0/-0,127	0.562 14,270	0/-0.0005 0/-0,127	0.740 18,796	0.015 0,381	0.015 0,381
5539	0.7500 19,050	0/-0.0005 0/-0,0127	1.1875 30,163	0/-0.0005 0/-0,0127	0.500 12,700	0/-0.0005 0/-0,127	0.562 14,270	0/-0.0005 0/-0,127	0.858 21,793	0.015 0,381	0.015 0,381
5540	0.8750 22,225	0/-0.0005 0/-0,0127	1.3125 33,338	0/-0.0005 0/-0,0127	0.500 12,700	0/-0.0005 0/-0,127	0.562 14,270	0/-0.0005 0/-0,127	0.976 24,779	0.015 0,381	0.015 0,381
5541	1.0625 26,987	0/-0.0005 0/-0,0127	1.5000 38,100	0/-0.0005 0/-0,0127	0.500 12,700	0/-0.0005 0/-0,127	0.562 14,270	0/-0.0005 0/-0,127	1.173 29,794	0.015 0,381	0.015 0,381
5542	1.3125 33,338	0/-0.0005 0/-0,0127	1.7500 44,450	0/-0.0005 0/-0,0127	0.500 12,700	0/-0.0005 0/-0,127	0.562 14,270	0/-0.0005 0/-0,127	1.417 35,992	0.015 0,381	0.015 0,381
5543	1.5625 39,687	0/-0.0005 0/-0,0127	2.0000 50,800	0/-0.0005 0/-0,0127	0.500 12,700	0/-0.0005 0/-0,127	0.562 14,270	0/-0.0005 0/-0,127	1.673 42,494	0.015 0,381	0.015 0,381
5544	1.8125 46,037	0/-0.0008 0/-0,0203	2.2500 57,150	0/-0.0007 0/-0,0178	0.500 12,700	0/-0.0005 0/-0,127	0.562 14,270	0/-0.0005 0/-0,127	1.949 49,505	0.015 0,381	0.015 0,381
5545	2.0625 52,387	0/-0.0008 0/-0,0203	2.6250 66,675	0/-0.0007 0/-0,0178	0.500 12,700	0/-0.0005 0/-0,127	0.562 14,270	0/-0.0005 0/-0,127	2.264 57,506	0.015 0,381	0.015 0,381
5546	2.3125 58,737	0/-0.0008 0/-0,0203	2.8750 73,025	0/-0.0007 0/-0,0178	0.500 12,700	0/-0.0005 0/-0,127	0.562 14,270	0/-0.0005 0/-0,127	2.508 63,703	0.015 0,381	0.015 0,381



Designation system

Examples:	ZWB5540DDSK2CP55RP01 B5538P	ZW	B	5540	DDSK2	CP55	RP01
Material and surface treatment							
No code	Cadmium plated bearing steel						
W	Corrosion-resistant steel						
S	Zinc-nickel plated bearing steel						
ZW	Cadmium plated corrosion-resistant steel						
SZW	Zinc-nickel plated corrosion-resistant steel						
Basic designation							
Bore code (multiples of 1/16 th inch)							
Variation							
	Lubricant	Version					
DDSK2	G354	Sealed					
DDSK281	G395	Sealed					
PG81	G395	Shielded					
P	G354	Shielded					
Passivation							
No code	Not treated						
CP55 ¹⁾	Passivated corrosion-resistant steel						
Oversize							
No code	Standard outer diameter size						
RP01	0.010 in/0,254 mm oversized outer diameter						
RP02	0.020 in/0,508 mm oversized outer diameter						

¹⁾ SKF option, available only for corrosion-resistant steel material without other surface treatment

Tolerances, loads and clearance

Nominal bore code	Mass ≈	Tolerances				Static limit loads		Radial clearance
		Kia max	Kea max	Sia max	Sea max	Radial C _s	Axial C _a	
–	lb/g	in/mm				lbf/kN		in/mm
5538	0.04	0.0020	0.0016	0.0020	0.0016	6 250	2 060	0.0008/ 0.0018
	18	0,0508	0,0406	0,0508	0,0406	27,80	9,16	0,0203/ 0,0457
5539	0.06	0.0020	0.0016	0.0020	0.0016	7 190	2 370	0.0008/ 0.0018
	27	0,0508	0,0406	0,0508	0,0406	31,98	10,54	0,0203/ 0,0457
5540	0.08	0.0020	0.0016	0.0020	0.0016	8 120	2 680	0.0008/ 0.0018
	36	0,0508	0,0406	0,0508	0,0406	36,12	11,92	0,0203/ 0,0457
5541	0.10	0.0020	0.0016	0.0020	0.0016	9 690	3 200	0.0008/ 0.0018
	45	0,0508	0,0406	0,0508	0,0406	43,10	14,23	0,0203/ 0,0457
5542	0.14	0.0020	0.0016	0.0020	0.0016	11 600	3 820	0.0008/ 0.0018
	64	0,0508	0,0406	0,0508	0,0406	52,00	16,99	0,0203/ 0,0457
5543	0.16	0.0020	0.0016	0.0020	0.0016	13 400	4 430	0.0008/ 0.0018
	73	0,0508	0,0406	0,0508	0,0406	59,61	19,70	0,0203/ 0,0457
5544	0.18	0.0020	0.0016	0.0020	0.0016	15 600	5 160	0.0008/ 0.0018
	82	0,0508	0,0406	0,0508	0,0406	69,39	22,95	0,0203/ 0,0457
5545	0.26	0.0020	0.0016	0.0020	0.0016	18 100	5 980	0.0008/ 0.0018
	118	0,0508	0,0406	0,0508	0,0406	80,51	26,60	0,0203/ 0,0457
5546	0.30	0.0020	0.0016	0.0020	0.0016	20 000	6 600	0.0008/ 0.0018
	136	0,0508	0,0406	0,0508	0,0406	88,96	29,36	0,0203/ 0,0457

1.20 Deep groove ball bearing double row (inch dimensions)

DPP..

Technical specification	AS 7949
Product standard	AS 27644

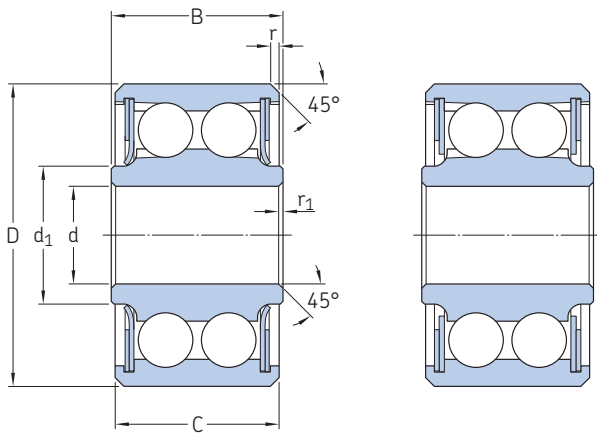

1.20

Dimensions

Nominal bore code	d	Δd_{mp}		Δd_s	D	ΔD_{mp}		ΔD_s	C	ΔC_s		
		Standard	SKF super precision			Standard	SKF super precision			Standard	SKF super precision	
in/mm												
3	0.1900	0/-0.0005	0/-0.0003	+0.0002/-0.0007	0.7774	0/-0.0005	0/-0.0004	+0.0005/-0.0010	0.473	0/-0.005	0/-0.005	
	4,826	0/-0.0127	0/-0.0076	+0.0050/-0.0178	19,745	0/-0.0127	0/-0.0101	+0.0127/-0.0254	12,014	0/-0.127	0/-0.127	
4	0.2500	0/-0.0005	0/-0.0003	+0.0002/-0.0007	0.9014	0/-0.0005	0/-0.0004	+0.0005/-0.0010	0.491	0/-0.005	0/-0.005	
	6,350	0/-0.0127	0/-0.0076	+0.0050/-0.0178	22,895	0/-0.0127	0/-0.0101	+0.0127/-0.0254	12,471	0/-0.127	0/-0.127	
5	0.3125	0/-0.0005	0/-0.0003	+0.0002/-0.0007	1.2500	0/-0.0005	0/-0.0004	+0.0005/-0.0010	0.687	0/-0.005	0/-0.005	
	7,938	0/-0.0127	0/-0.0076	+0.0050/-0.0178	31,750	0/-0.0127	0/-0.0101	+0.0127/-0.0254	17,449	0/-0.127	0/-0.127	
6	0.3750	0/-0.0005	0/-0.0003	+0.0002/-0.0007	1.4375	0/-0.0005	0/-0.0004	+0.0005/-0.0010	0.794	0/-0.005	0/-0.005	
	9,525	0/-0.0127	0/-0.0076	+0.0050/-0.0178	36,513	0/-0.0127	0/-0.0101	+0.0127/-0.0254	20,167	0/-0.127	0/-0.127	
8	0.5000	0/-0.0005	0/-0.0003	+0.0002/-0.0007	1.6875	0/-0.0005	0/-0.0004	+0.0005/-0.0010	0.856	0/-0.005	0/-0.005	
	12,700	0/-0.0127	0/-0.0076	+0.0050/-0.0178	42,862	0/-0.0127	0/-0.0101	+0.0127/-0.0254	21,742	0/-0.127	0/-0.127	
10	0.6250	0/-0.0005	0/-0.0003	+0.0002/-0.0007	1.9375	0/-0.0005	0/-0.0004	+0.0005/-0.0010	0.920	0/-0.005	0/-0.005	
	15,875	0/-0.0127	0/-0.0076	+0.0050/-0.0178	49,212	0/-0.0127	0/-0.0101	+0.0127/-0.0254	23,368	0/-0.127	0/-0.127	

Dimensions cont. and tolerances

Nominal bore code	Dimensions			d_1	r_1	r	Mass \approx	Tolerances			Sia max Standard	SKF super precision	
	B	ΔB_s	Standard					Kia max Standard	SKF super precision	Kea max Standard			SKF super precision
in/mm													
3	0.495	0/-0.005	0/-0.0025	0.302	0.005	0.018	0.04	0.0010	0.0005	0.0016	0.0008	0.0010	0.0007
	12,573	0/-0.127	0/-0.0635	7,670	0,127	0,450	18	0,0254	0,0127	0,0406	0,0203	0,0254	0,0178
4	0.620	0/-0.005	0/-0.0025	0.410	0.005	0.032	0.06	0.0010	0.0005	0.0016	0.0008	0.0010	0.0007
	15,748	0/-0.127	0/-0.0635	10,414	0,127	0,813	27	0,0254	0,0127	0,0406	0,0203	0,0254	0,0178
5	0.745	0/-0.005	0/-0.0025	0.469	0.015	0.032	0.17	0.0010	0.0005	0.0016	0.0008	0.0010	0.0007
	18,923	0/-0.127	0/-0.0635	11,912	0,381	0,813	77	0,0254	0,0127	0,0406	0,0203	0,0254	0,0178
6	0.870	0/-0.005	0/-0.0025	0.551	0.015	0.032	0.26	0.0010	0.0005	0.0016	0.0008	0.0010	0.0007
	22,098	0/-0.127	0/-0.0635	13,995	0,381	0,813	118	0,0254	0,0127	0,0406	0,0203	0,0254	0,0178
8	0.932	0/-0.005	0/-0.0025	0.735	0.015	0.044	0.38	0.0010	0.0005	0.0016	0.0008	0.0010	0.0007
	23,672	0/-0.127	0/-0.0635	18,669	0,381	1,118	172	0,0254	0,0127	0,0406	0,0203	0,0254	0,0178
10	0.995	0/-0.005	0/-0.0025	0.890	0.015	0.044	0.53	0.0010	0.0005	0.0016	0.0008	0.0010	0.0007
	25,273	0/-0.127	0/-0.0635	22,606	0,381	1,118	240	0,0254	0,0127	0,0406	0,0203	0,0254	0,0178



Designation system

Examples: ZWMDPP10SK2CP55RP01
DPP 3P

Material and surface treatment

No code Cadmium plated bearing steel
W¹⁾ Corrosion-resistant steel
S Zinc-nickel plated bearing steel
ZW¹⁾ Cadmium plated corrosion-resistant steel
SZW¹⁾ Zinc-nickel plated corrosion-resistant steel

Tolerances

No code Standard tolerances
M¹⁾ Reduced clearance and SKF super precision

Basic designation

Bore code (multiples of 1/16th inch)

Variation

	Lubricant	Version	Radial clearance	
			DPP..	MDPP.. ¹⁾
SK2	G354	Sealed	Standard	Reduced
S281	G395	Sealed	Standard	Reduced
S281-R¹⁾	G395	Sealed	Reduced	–
SK2-R¹⁾	G354	Sealed	Reduced	–
P¹⁾	G354	Shielded	Standard	Reduced
PG81¹⁾	G395	Shielded	Standard	Reduced
PG81-R¹⁾	G395	Shielded	Reduced	–
P-R¹⁾	G354	Shielded	Reduced	–

Passivation

No code Not treated
CP55²⁾ Passivated corrosion-resistant steel

Oversize

No code Standard outer diameter size
RP01¹⁾ 0.010 in/0,254 mm oversized outer diameter
RP02¹⁾ 0.020 in/0,508 mm oversized outer diameter

¹⁾ SKF option

²⁾ SKF option, available only for corrosion-resistant steel material without other surface treatment

Tolerances cont., loads, clearance and torque

Nominal bore code	Tolerances		Static limit loads		Radial dynamic load rating ³⁾⁴⁾		Radial clearance		Maximum starting torque ⁵⁾	
	Sea max Standard	SKF super precision	Radial C _s	Axial C _a	Load fixed with respect to outer ring inner ring		Standard	Reduced	Shielded	Sealed
–	in/mm		lbf/kN				in/mm		oz-in/mNm	
3	0.0016	0.0010	2 950	1 700	2 950	2 830	0.0004/ 0.0010	0.0002/ 0.0005	0.67	1
	0,0406	0,0254	13,12	7,56	13,12	12,59	0,0101/ 0,0254	0,0051/ 0,0127	4,71	7,06
4	0.0016	0.0010	5 370	1 800	3 550	3 020	0.0004/ 0.0010	0.0002/ 0.0005	0.67	1
	0,0406	0,0254	23,89	8,01	15,79	13,43	0,0101/ 0,0254	0,0051/ 0,0127	4,71	7,06
5	0.0016	0.0010	11 000	4 000	7 360	6 250	0.0004/ 0.0010	0.0002/ 0.0005	0.67	1.5
	0,0406	0,0254	48,93	17,79	32,74	27,80	0,0101/ 0,0254	0,0051/ 0,0127	4,71	10,59
6	0.0016	0.0010	15 760	5 300	9 690	8 120	0.0004/ 0.0010	0.0002/ 0.0005	1.33	2
	0,0406	0,0254	70,10	23,58	43,10	36,12	0,0101/ 0,0254	0,0051/ 0,0127	9,41	14,12
8	0.0016	0.0010	23 600	7 800	14 100	11 600	0.0004/ 0.0010	0.0002/ 0.0005	1.33	3
	0,0406	0,0254	105,00	34,70	62,72	51,60	0,0101/ 0,0254	0,0051/ 0,0127	9,41	21,18
10	0.0016	0.0010	28 400	9 400	15 300	13 100	0.0004/ 0.0010	0.0002/ 0.0005	2	4.5
	0,0406	0,0254	126,33	41,81	68,06	58,27	0,0101/ 0,0254	0,0051/ 0,0127	14,12	31,78

³⁾ For average life of 10 000 cycles at $\theta = 90^\circ$ oscillation, see page 38

⁴⁾ If G395 load rating is 20% lower

⁵⁾ Values are valid for bearings with G395. When using G354, values are 20% higher

1.21 Deep groove ball bearing double row (inch dimensions)

DW., DW..K, DW..K2

Technical specification	AS 7949
Product standard	AS 27647

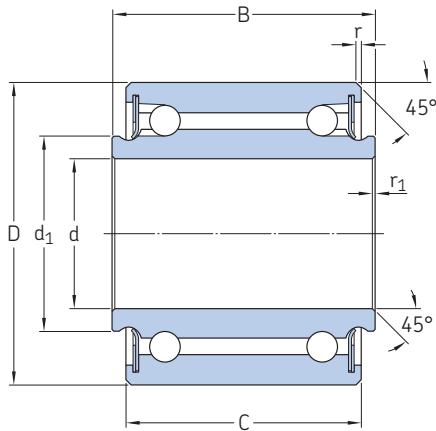

Dimensions

Nominal bore code	Dimensions		Δds	D	ΔDmp		ΔDs	C	ΔCs		
	d	Δdmp			Standard	SKF super precision			Standard	SKF super precision	Standard
–	in/mm										
4K2	0.2500 6,350	0/-0.0005 0/-0.0127	0/-0.0003 0/-0.0076	+0.0002/-0.0007 +0.0050/-0.0178	0.6250 15,875	0/-0.0005 0/-0.0127	0/-0.0004 0/-0.0101	+0.0005/-0.0010 +0.0127/-0.0254	0.500 12,700	0/-0.005 0/-0.127	0/-0.005 0/-0.127
4K	0.2500 6,350	0/-0.0005 0/-0.0127	0/-0.0003 0/-0.0076	+0.0002/-0.0007 +0.0050/-0.0178	0.7500 19,050	0/-0.0005 0/-0.0127	0/-0.0004 0/-0.0101	+0.0005/-0.0010 +0.0127/-0.0254	0.750 19,050	0/-0.005 0/-0.127	0/-0.005 0/-0.127
4¹⁾	0.2500 6,350	0/-0.0005 0/-0.0127	0/-0.0003 0/-0.0076	+0.0002/-0.0007 +0.0050/-0.0178	0.7500 19,050	0/-0.0005 0/-0.0127	0/-0.0004 0/-0.0101	+0.0005/-0.0010 +0.0127/-0.0254	0.750 19,050	0/-0.005 0/-0.127	0/-0.005 0/-0.127
5	0.3125 7,938	0/-0.0005 0/-0.0127	0/-0.0003 0/-0.0076	+0.0002/-0.0007 +0.0050/-0.0178	0.8750 22,225	0/-0.0005 0/-0.0127	0/-0.0004 0/-0.0101	+0.0005/-0.0010 +0.0127/-0.0254	0.813 20,650	0/-0.005 0/-0.127	0/-0.005 0/-0.127
6	0.3750 9,525	0/-0.0005 0/-0.0127	0/-0.0003 0/-0.0076	+0.0002/-0.0007 +0.0050/-0.0178	1.0625 26,988	0/-0.0005 0/-0.0127	0/-0.0004 0/-0.0101	+0.0005/-0.0010 +0.0127/-0.0254	1.063 27,000	0/-0.005 0/-0.127	0/-0.005 0/-0.127
8	0.5000 12,700	0/-0.0005 0/-0.0127	0/-0.0003 0/-0.0076	+0.0002/-0.0007 +0.0050/-0.0178	1.4375 36,513	0/-0.0005 0/-0.0127	0/-0.0004 0/-0.0101	+0.0005/-0.0010 +0.0127/-0.0254	1.375 34,925	0/-0.005 0/-0.127	0/-0.005 0/-0.127

Dimensions cont. and tolerances

Nominal bore code	Dimensions		d_1	r_1	r	Mass	Tolerances		Kea max	SKF super precision	Sia max	SKF super precision
	B	ΔBs					Standard	SKF super precision				
–	in/mm											
4K2	0.562 14,275	0/-0.005 0/-0.127	0.344 8,738	0.005 0,127	0.016 0,406	0.025 11	0.0010 0,0254	0.0005 0,0127	0.0016 0,0406	0.0008 0,0203	0.0010 0,0254	0.0007 0,0178
4K	0.875 22,225	0/-0.005 0/-0.127	0.385 9,779	0.005 0,127	0.016 0,406	0.04 18	0.0010 0,0254	0.0005 0,0127	0.0016 0,0406	0.0008 0,0203	0.0010 0,0254	0.0007 0,0178
4¹⁾	0.875 22,225	0/-0.005 0/-0.127	0.375 9,525	0.005 0,127	0.016 0,406	0.06 27	0.0010 0,0254	0.0005 0,0127	0.0016 0,0406	0.0008 0,0203	0.0010 0,0254	0.0007 0,0178
5	0.938 23,825	0/-0.005 0/-0.127	0.472 11,989	0.005 0,127	0.016 0,406	0.07 32	0.0010 0,0254	0.0005 0,0127	0.0016 0,0406	0.0008 0,0203	0.0010 0,0254	0.0007 0,0178
6	1.188 30,175	0/-0.005 0/-0.127	0.576 14,630	0.005 0,127	0.016 0,406	0.12 54	0.0010 0,0254	0.0005 0,0127	0.0016 0,0406	0.0008 0,0203	0.0010 0,0254	0.0007 0,0178
8	1.500 38,100	0/-0.005 0/-0.127	0.715 18,161	0.005 0,127	0.032 0,813	0.29 132	0.0010 0,0254	0.0005 0,0127	0.0016 0,0406	0.0008 0,0203	0.0010 0,0254	0.0007 0,0178



Designation system

Examples: ZWMDW 6SK2CP55RP01
DW 4K2S281-R

Material and surface treatment

No code Cadmium plated bearing steel
W¹⁾ Corrosion-resistant steel
S Zinc-nickel plated bearing steel
ZW¹⁾ Cadmium plated corrosion-resistant steel
SZW¹⁾ Zinc-nickel plated corrosion-resistant steel

Tolerances

No code Standard tolerances
M¹⁾ Reduced clearance and SKF super precision

Basic designation

Bore code (multiples of 1/16th inch)

Variation

	Lubricant	Version	Radial clearance	
			DW..	MDW.. ¹⁾
SK2	G354	Sealed	Standard	Reduced
S281	G395	Sealed	Standard	Reduced
S281-R	G395	Sealed	Reduced	–
SK2-R	G354	Sealed	Reduced	–

Passivation

No code Not treated
CP55²⁾ Passivated corrosion-resistant steel

Oversize

No code Standard outer diameter size
RP01¹⁾ 0.010 in/0,254 mm oversized outer diameter
RP02¹⁾ 0.020 in/0,508 mm oversized outer diameter

1) SKF option

2) SKF option, available only for corrosion-resistant steel material without other surface treatment

Tolerances cont., loads, clearance and torque

Nominal bore code	Tolerances		Static limit loads		Radial dynamic load rating ³⁾⁴⁾		Radial clearance		Maximum starting torque ⁵⁾
	Sea max Standard	SKF super precision	Radial C _s	Axial C _a	Load fixed with respect to outer ring inner ring		Standard	Reduced	
–	in/mm		lbf/kN				in/mm		oz-in/mNm
4K2	0.0016	0.0010	1 400	500	1 050	960	0/0.0010	0.0002/0.0005	1
	0,0406	0,0254	6,23	2,22	4,67	4,27	0/0,0254	0,0051/0,0127	7,06
4K	0.0016	0.0010	2 770	900	2 070	1 850	0/0.0010	0.0002/0.0005	1
	0,0406	0,0254	12,32	4,00	9,21	8,23	0/0,0254	0,0051/0,0127	7,06
4 ¹⁾	0.0016	0.0010	3 750	1 240	2 070	1 850	0/0.0010	0.0002/0.0005	1
	0,0406	0,0254	16,68	5,52	9,21	8,23	0/0,0254	0,0051/0,0127	7,06
5	0.0016	0.0010	5 140	1 600	2 600	2 320	0/0.0010	0.0002/0.0005	1.5
	0,0406	0,0254	22,86	7,12	11,57	10,32	0/0,0254	0,0051/0,0127	10,59
6	0.0016	0.0010	8 440	2 600	4 220	3 740	0/0.0010	0.0002/0.0005	2.5
	0,0406	0,0254	37,54	11,57	18,77	16,64	0/0,0254	0,0051/0,0127	17,65
8	0.0016	0.0010	15 520	4 700	7 610	6 520	0/0.0010	0.0002/0.0005	2.5
	0,0406	0,0254	69,04	20,91	33,85	29,00	0/0,0254	0,0051/0,0127	17,65

3) For average life of 10 000 cycles at $\theta = 90^\circ$ oscillation, see page 38

4) If G395 load rating is 20% lower

5) Values are valid for bearings with G354. When using G395, values are 20% higher

1.22 Deep groove ball bearing with self-aligning ring single row (inch dimensions)

KP..BS bore code **16** to **21**

Technical specification	AS 7949
Product standard	AS 27648

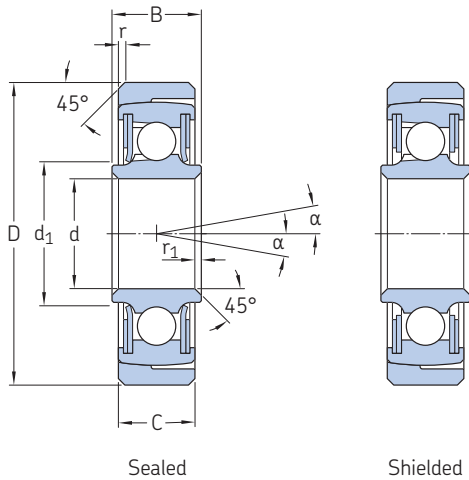

Dimensions

Nominal Dimensions

bore code	d	Δd_{mp} Standard	SKF super precision	Δd_s	D	ΔD_{mp} Standard	SKF super precision	ΔD_s	C	ΔC_s Standard	SKF super precision
–	in/mm										
16	1.0000 25,400	0/-0.0005 0/-0,0127	0/-0.0005 0/-0,0127	+0.0003/-0.0008 +0,0076/-0,0203	1.9375 49,212	0/-0.0010 0/-0,0254	0/-0.0010 0/-0,0254	+0.0010/-0.0020 +0,0254/-0,0508	0.375 9,525	0/-0.005 0/-0,127	0/-0.005 0/-0,127
21	1.3130 33,350	0/-0.0010 0/-0,0254	-0.0005/-0.0010 -0,0127/-0,0254	+0.0008/-0.0008 +0,0203/-0,0203	2.2500 57,150	0/-0.0010 0/-0,0254	0/-0.0010 0/-0,0254	+0.0010/-0.0020 +0,0254/-0,0508	0.375 9,525	0/-0.005 0/-0,127	0/-0.005 0/-0,127
23	1.4380 36,525	0/-0.0010 0/-0,0254	-0.0005/-0.0010 -0,0127/-0,0254	+0.0008/-0.0008 +0,0203/-0,0203	2.3750 60,325	0/-0.0010 0/-0,0254	0/-0.0010 0/-0,0254	+0.0010/-0.0020 +0,0254/-0,0508	0.375 9,525	0/-0.005 0/-0,127	0/-0.005 0/-0,127
25	1.5630 39,700	0/-0.0010 0/-0,0254	-0.0005/-0.0010 -0,0127/-0,0254	+0.0008/-0.0008 +0,0203/-0,0203	2.5000 63,500	0/-0.0010 0/-0,0254	0/-0.0010 0/-0,0254	+0.0010/-0.0020 +0,0254/-0,0508	0.375 9,525	0/-0.005 0/-0,127	0/-0.005 0/-0,127
29	1.8130 46,050	0/-0.0010 0/-0,0254	-0.0005/-0.0010 -0,0127/-0,0254	+0.0008/-0.0008 +0,0203/-0,0203	2.7500 69,850	0/-0.0010 0/-0,0254	0/-0.0010 0/-0,0254	+0.0010/-0.0020 +0,0254/-0,0508	0.375 9,525	0/-0.005 0/-0,127	0/-0.005 0/-0,127

Dimensions cont. and tolerances

Nominal Dimensions

bore code	B	ΔB_s Standard	SKF super precision	d_1 ≈	r_1 +0.015/0 +0,381/0	r +0.015/0 +0,381/0	α	Mass ≈	Tolerances Kia max Standard	SKF super precision	Kia max Standard	SKF super precision	
–	in/mm							°	lb/g	in/mm			
16	0.437 11,099	0/-0.005 0/-0,127	0/-0.0025 0/-0,0635	1.141 28,981	0.0240 0,610	0.0240 0,610	7°25'	0.18 82	0.0010 0,0254	0.0008 0,0203	0.0016 0,0406	0.0008 0,0203	
21	0.437 11,099	0/-0.005 0/-0,127	0/-0.0025 0/-0,0635	1.454 36,931	0.0240 0,610	0.0240 0,610	6°30'	0.20 90	0.0010 0,0254	0.0008 0,0203	0.0016 0,0406	0.0008 0,0203	
23	0.437 11,099	0/-0.005 0/-0,127	0/-0.0025 0/-0,0635	1.574 39,979	0.0240 0,610	0.0240 0,610	6°	0.22 99	0.0010 0,0254	0.0008 0,0203	0.0016 0,0406	0.0008 0,0203	
25	0.437 11,099	0/-0.005 0/-0,127	0/-0.0025 0/-0,0635	1.693 43,002	0.0240 0,838	0.0240 0,838	5°45'	0.25 113	0.0010 0,0254	0.0008 0,0203	0.0016 0,0406	0.0008 0,0203	
29	0.437 11,099	0/-0.005 0/-0,127	0/-0.0025 0/-0,0635	1.931 49,047	0.0240 0,610	0.0240 0,610	5°	0.27 122	0.0010 0,0254	0.0008 0,0203	0.0016 0,0406	0.0008 0,0203	



Designation system

Examples: ZWMKP16BSSK2CP55RP01
 KP29BSP

Material and surface treatment

No code Cadmium plated bearing steel
W¹⁾ Corrosion-resistant steel
S Zinc-nickel plated bearing steel
ZW¹⁾ Cadmium plated corrosion-resistant steel
SZW¹⁾ Zinc-nickel plated corrosion-resistant steel

Tolerances and radial clearance

No code Standard clearance and tolerances
M¹⁾ Reduced clearance and SKF super precision

Basic designation

Bore code (multiples of 1/16th inch)

Variation

	Lubricant	Version
SK2	G354	Sealed
S281	G395	Sealed
PG81¹⁾	G395	Shielded
P¹⁾	G354	Shielded

Passivation

No code Not treated
CP55²⁾ Passivated corrosion-resistant steel

Oversize

No code Standard outer diameter size
RP01¹⁾ 0.010 in/0,254 mm oversized outer diameter
RP02¹⁾ 0.020 in/0,508 mm oversized outer diameter

¹⁾ SKF option

²⁾ SKF option, available only for corrosion-resistant steel material without other surface treatment

Tolerances cont., loads, clearance and torque

Nominal bore code	Tolerances				Static limit loads		Radial dynamic load rating ³⁾⁴⁾		Radial clearance		Maximum starting torque ⁵⁾	
	Sia max Standard	SKF super precision	Sea max Standard	SKF super precision	Radial C _s	Axial C _a	Load fixed with respect to outer ring	inner ring	Standard	Reduced	Shielded	Sealed
–	in/mm				lbf/kN				in/mm		oz-in/mNm	
16	0.0010 0,0254	0.0008 0,0203	0.0016 0,0406	0.0010 0,0254	8 085 35,96	1 600 7,12	4 260 18,95	3 960 17,61	0.0003/0.0010 0,0076/0,0254	0.0001/0.0005 0,0025/0,0127	3.33 23,53	5 35,3
21	0.0010 0,0254	0.0008 0,0203	0.0016 0,0406	0.0010 0,0254	9 840 43,77	2 000 8,90	4 590 20,42	4 290 19,08	0.0003/0.0010 0,0076/0,0254	0.0001/0.0005 0,0025/0,0127	4.67 32,95	7 49,42
23	0.0010 0,0254	0.0008 0,0203	0.0016 0,0406	0.0010 0,0254	10 500 46,71	2 200 9,79	4 650 20,68	4 360 19,39	0.0003/0.0010 0,0076/0,0254	0.0001/0.0005 0,0025/0,0127	5.33 37,65	9 63,54
25	0.0010 0,0254	0.0008 0,0203	0.0016 0,0406	0.0010 0,0254	11 300 50,27	2 300 10,23	4 680 20,82	4 420 19,66	0.0003/0.0010 0,0076/0,0254	0.0001/0.0005 0,0025/0,0127	6 42,37	9 63,54
29	0.0010 0,0254	0.0008 0,0203	0.0016 0,0406	0.0010 0,0254	12 700 56,49	2 600 11,57	4 760 21,17	4 530 20,15	0.0003/0.0010 0,0076/0,0254	0.0001/0.0005 0,0025/0,0127	8 56,48	14 98,84

³⁾ For average life of 10 000 cycles at $\theta = 90^\circ$ oscillation, see page 38

⁴⁾ If G395 load rating is 20% lower

⁵⁾ Values are valid for bearings with G395. When using G354, values are 20% higher

1.22 Deep groove ball bearing with self-aligning ring single row (inch dimensions)

KP..BS bore code 33 to 49

Technical specification	AS 7949
Product standard	AS 27648

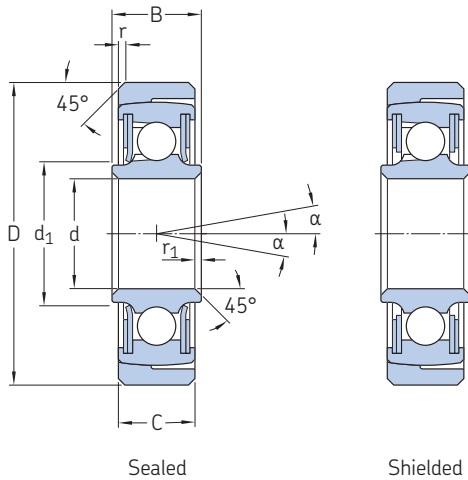

Dimensions

Nominal Dimensions

bore code	d	Δd_{mp} Standard	SKF super precision	Δd_s	D	ΔD_{mp} Standard	SKF super precision	ΔD_s	C	ΔC_s Standard	SKF super precision
–	in/mm										
33	2.0630 52,400	0/–0.0010 0/–0,0254	–0.0005/–0.0010 –0,0127/–0,0254	+0.0008/–0.0008 +0,0127/–0,0381	3.0000 76,200	0/–0.0010 0/–0,0254	0/–0.0010 0/–0,0254	+0.0010/–0.0020 +0,0254/–0,0508	0.375 9,525	0/–0.005 0/–0,127	0/–0.005 0/–0,127
37	2.3130 58,750	0/–0.0010 0/–0,0254	–0.0005/–0.0010 –0,0127/–0,0254	+0.0008/–0.0008 +0,0203/–0,0203	3.2500 82,550	0/–0.0010 0/–0,0254	0/–0.0010 0/–0,0254	+0.0010/–0.0020 +0,0254/–0,0508	0.375 9,525	0/–0.005 0/–0,127	0/–0.005 0/–0,127
47	2.9380 74,625	0/–0.0010 0/–0,0254	–0.0005/–0.0010 –0,0127/–0,0254	+0.0008/–0.0008 +0,0203/–0,0203	4.1250 104,775	0/–0.0010 0/–0,0254	0/–0.0010 0/–0,0254	+0.0010/–0.0020 +0,0254/–0,0508	0.469 11,912	0/–0.005 0/–0,127	0/–0.005 0/–0,127
48	3.0005 76,213	0/–0.0010 0/–0,0254	–0.0005/–0.0010 –0,0127/–0,0254	+0.0008/–0.0008 +0,0203/–0,0203	4.2500 107,950	0/–0.0010 0/–0,0254	0/–0.0010 0/–0,0254	+0.0010/–0.0020 +0,0254/–0,0508	0.469 11,912	0/–0.005 0/–0,127	0/–0.005 0/–0,127
49	3.0630 77,800	0/–0.0010 0/–0,0254	–0.0005/–0.0010 –0,0127/–0,0254	+0.0008/–0.0008 +0,0203/–0,0203	4.2500 107,950	0/–0.0010 0/–0,0254	0/–0.0010 0/–0,0254	+0.0010/–0.0020 +0,0254/–0,0508	0.469 11,912	0/–0.005 0/–0,127	0/–0.005 0/–0,127

Dimensions cont. and tolerances

Nominal Dimensions

bore code	B	ΔB_s Standard	SKF super precision	d_1 ≈	r_1 +0.015/0 +0,381/0	r +0.015/0 +0,381/0	α	Mass ≈	Tolerances Kia max Standard	SKF super precision	Kea max Standard	SKF super precision	
–	in/mm							°	lb/g	in/mm			
33	0.437 11,099	0/–0.005 0/–0,127	0/–0.0025 0/–0,0635	2.231 56,667	0.0240 0,610	0.0240 0,610	5°	0,30 136	0.0010 0,0254	0.0008 0,0203	0.0016 0,0406	0.0008 0,0203	
37	0.437 11,099	0/–0.005 0/–0,127	0/–0.0025 0/–0,0635	2.468 62,687	0.0240 0,610	0.0240 0,610	4°30'	0,33 150	0.0010 0,0254	0.0008 0,0203	0.0016 0,0406	0.0008 0,0203	
47	0.531 13,487	0/–0.005 0/–0,127	0/–0.0025 0/–0,0635	3.093 78,562	0.0390 0,990	0.0390 0,990	4°30'	0,64 290	0.0010 0,0254	0.0008 0,0203	0.0016 0,0406	0.0008 0,0203	
48	0.531 13,487	0/–0.005 0/–0,127	0/–0.0025 0/–0,0635	3.222 81,838	0.0390 0,990	0.0390 0,990	4°	0,69 313	0.0010 0,0254	0.0008 0,0203	0.0016 0,0406	0.0008 0,0203	
49	0.531 13,487	0/–0.005 0/–0,127	0/–0.0025 0/–0,0635	3.222 81,838	0.0390 0,990	0.0390 0,990	4°	0,69 313	0.0010 0,0254	0.0008 0,0203	0.0016 0,0406	0.0008 0,0203	



Designation system

Examples: ZWMP16BSSK2CP55RP01
KP29BSP

ZW M KP 16 BS SK2 CP55 RP01

Material and surface treatment

No code Cadmium plated bearing steel
W¹⁾ Corrosion-resistant steel
S Zinc-nickel plated bearing steel
ZW¹⁾ Cadmium plated corrosion-resistant steel
SZW¹⁾ Zinc-nickel plated corrosion-resistant steel

Tolerances and radial clearance

No code Standard clearance and tolerances
M¹⁾ Reduced clearance and SKF super precision

Basic designation

Bore code (multiples of 1/16th inch)

Variation

	Lubricant	Version
SK2	G354	Sealed
S281	G395	Sealed
PG81¹⁾	G395	Shielded
P¹⁾	G354	Shielded

Passivation

No code Not treated
CP55²⁾ Passivated corrosion-resistant steel

Oversize

No code Standard outer diameter size
RP01¹⁾ 0.010 in/0,254 mm oversized outer diameter
RP02¹⁾ 0.020 in/0,508 mm oversized outer diameter

¹⁾ SKF option

²⁾ SKF option, available only for corrosion-resistant steel material without other surface treatment

Tolerances cont., loads, clearance and torque

Nominal bore code	Tolerances				Static limit loads		Radial dynamic load rating ³⁾⁴⁾		Radial clearance		Maximum starting torque ⁵⁾	
	Sia max Standard	SKF super precision	Sea max Standard	SKF super precision	Radial C _s	Axial C _a	Load fixed with respect to outer ring	inner ring	Standard	Reduced	Shielded	Sealed
–	in/mm				lbf/kN				in/mm		oz-in/mNm	
33	0.0010 0,0254	0.0008 0,0203	0.0016 0,0406	0.0010 0,0254	14 400 64,05	2 900 12,90	4 820 21,44	4 630 20,60	0.0003/0.0010 0,0076/0,0254	0.0001/0.0005 0,0025/0,0127	9.33 65,89	14 98,84
37	0.0010 0,0254	0.0008 0,0203	0.0016 0,0406	0.0010 0,0254	15 800 70,28	3 200 14,23	4 880 21,71	4 690 20,86	0.0003/0.0010 0,0076/0,0254	0.0001/0.0005 0,0025/0,0127	11.33 80,01	20 141,23
47	0.0010 0,0254	0.0008 0,0203	0.0016 0,0406	0.0010 0,0254	24 700 109,87	5 000 22,24	6 600 29,36	6 390 28,42	0.0003/0.0010 0,0076/0,0254	0.0001/0.0005 0,0025/0,0127	16 112,96	30 211,85
48	0.0010 0,0254	0.0008 0,0203	0.0016 0,0406	0.0010 0,0254	27 500 122,33	5 500 24,47	8 150 36,25	7 840 34,87	0.0003/0.0010 0,0076/0,0254	0.0001/0.0005 0,0025/0,0127	16.67 117,67	30 211,85
49	0.0010 0,0254	0.0008 0,0203	0.0016 0,0406	0.0010 0,0254	27 500 122,33	5 500 24,47	8 150 36,25	7 840 34,87	0.0003/0.0010 0,0076/0,0254	0.0001/0.0005 0,0025/0,0127	17.33 122,37	32 225,97

³⁾ For average life of 10 000 cycles at $\theta = 90^\circ$ oscillation, see page 38

⁴⁾ If G395 load rating is 20% lower

⁵⁾ Values are valid for bearings with G395. When using G354, values are 20% higher

1.23 Self-aligning ball bearing single row (inch dimensions)

KSP.., KSP..A, KSP..L bore code 3L to 5

Technical specification	AS 7949
Product standard	AS 27645

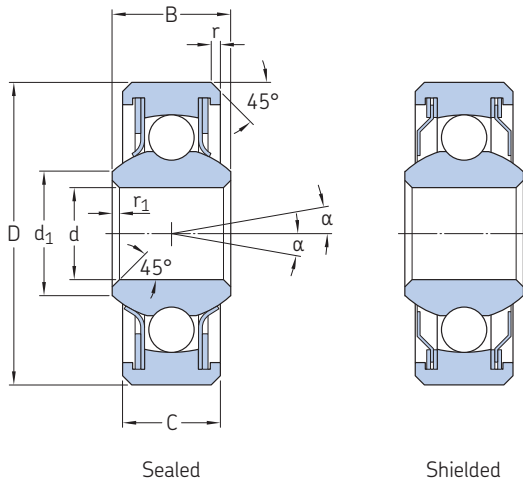

Dimensions

Nominal Dimensions

bore code	d	Δ dmp Standard	SKF super precision	Δ ds	D	Δ Dmp Standard	SKF super precision	Δ Ds	C	Δ Cs Standard	SKF super precision
–	in/mm										
3L	0.1900 4,826	0/-0.0005 0/-0.0127	0/-0.0003 0/-0.0076	+0.0002/-0.0007 +0.0050/-0.0178	0.6250 15,875	0/-0.0005 0/-0.0127	0/-0.0004 0/-0.0101	+0.0005/-0.0010 +0.0127/-0.0254	0.203 5,156	0/-0.005 0/-0.127	0/-0.005 0/-0.127
3	0.1900 4,826	0/-0.0005 0/-0.0127	0/-0.0003 0/-0.0076	+0.0002/-0.0007 +0.0050/-0.0178	0.7774 19,746	0/-0.0005 0/-0.0127	0/-0.0004 0/-0.0101	+0.0005/-0.0010 +0.0127/-0.0254	0.270 6,858	0/-0.005 0/-0.127	0/-0.005 0/-0.127
4A	0.2500 6,350	0/-0.0005 0/-0.0127	0/-0.0003 0/-0.0076	+0.0002/-0.0007 +0.0050/-0.0178	0.7500 19,050	0/-0.0005 0/-0.0127	0/-0.0004 0/-0.0101	+0.0005/-0.0010 +0.0127/-0.0254	0.219 5,562	0/-0.005 0/-0.127	0/-0.005 0/-0.127
4	0.2500 6,350	0/-0.0005 0/-0.0127	0/-0.0003 0/-0.0076	+0.0002/-0.0007 +0.0050/-0.0178	0.9014 22,896	0/-0.0005 0/-0.0127	0/-0.0004 0/-0.0101	+0.0005/-0.0010 +0.0127/-0.0254	0.335 8,509	0/-0.005 0/-0.127	0/-0.005 0/-0.127
5A	0.3125 7,938	0/-0.0005 0/-0.0127	0/-0.0003 0/-0.0076	+0.0002/-0.0007 +0.0050/-0.0178	0.8125 20,638	0/-0.0005 0/-0.0127	0/-0.0004 0/-0.0101	+0.0005/-0.0010 +0.0127/-0.0254	0.234 5,944	0/-0.005 0/-0.127	0/-0.005 0/-0.127
5	0.3125 7,938	0/-0.0005 0/-0.0127	0/-0.0003 0/-0.0076	+0.0002/-0.0007 +0.0050/-0.0178	1.2500 31,750	0/-0.0005 0/-0.0127	0/-0.0004 0/-0.0101	+0.0005/-0.0010 +0.0127/-0.0254	0.375 9,525	0/-0.005 0/-0.127	0/-0.005 0/-0.127

Dimensions cont. and tolerances

Nominal Dimensions

bore code	B	Δ Bs Standard	SKF super precision	d_1 ≈	r_1 +0.015/0 +0,381/0	r +0.015/0 +0,381/0	α	Mass ≈	Tolerances Kia max Standard	SKF super precision	Kia max Standard	SKF super precision	
–	in/mm							°	lb/g	in/mm			
3L	0.245 6,223	0/-0.005 0/-0.127	0/-0.0025 0/-0.0635	0.256 6,502	0.005 0,127	0.016 0,406	10	0,01 5	0.0010 0,0254	0.0005 0,0127	0.0016 0,0406	0.0008 0,0203	
3	0.297 7,544	0/-0.005 0/-0.127	0/-0.0025 0/-0.0635	0.297 7,544	0.005 0,127	0.022 0,559	10	0.03 14	0.0010 0,0254	0.0005 0,0127	0.0016 0,0406	0.0008 0,0203	
4A	0.281 7,137	0/-0.005 0/-0.127	0/-0.0025 0/-0.0635	0.328 8,331	0.005 0,127	0.016 0,406	8	0,02 9	0.0010 0,0254	0.0005 0,0127	0.0016 0,0406	0.0008 0,0203	
4	0.484 12,294	0/-0.005 0/-0.127	0/-0.0025 0/-0.0635	0.396 10,058	0.005 0,127	0.032 0,813	10	0.04 18	0.0010 0,0254	0.0005 0,0127	0.0016 0,0406	0.0008 0,0203	
5A	0.297 7,544	0/-0.005 0/-0.127	0/-0.0025 0/-0.0635	0.389 9,880	0.015 0,381	0.016 0,406	8	0,02 9	0.0010 0,0254	0.0005 0,0127	0.0016 0,0406	0.0008 0,0203	
5	0.558 14,173	0/-0.005 0/-0.127	0/-0.0025 0/-0.0635	0.567 14,402	0.015 0,381	0.032 0,813	10	0.10 45	0.0010 0,0254	0.0005 0,0127	0.0016 0,0406	0.0008 0,0203	



Designation system

Examples: ZWMKSP 6ASK1CP55RP01
KSP 3P

Material and surface treatment

No code Cadmium plated bearing steel
W¹⁾ Corrosion-resistant steel
S Zinc-nickel plated bearing steel
ZW¹⁾ Cadmium plated corrosion-resistant steel
SZW¹⁾ Zinc-nickel plated corrosion-resistant steel

Tolerances

No code Standard tolerances
M¹⁾ Reduced clearance and SKF super precision

Basic designation

Bore code (multiples of 1/16th inch)

Variation

	Lubricant	Shield and seal	Radial clearance KSP..	MKSP.. ¹⁾
SK1	G354	Sealed	Standard	Reduced
S181	G395	Sealed	Standard	Reduced
S181-R	G395	Sealed	Reduced	–
SK1-R	G354	Sealed	Reduced	–
P¹⁾	G354	Shielded	Standard	Reduced
PG81¹⁾	G395	Shielded	Standard	Reduced
PG81-R¹⁾	G395	Shielded	Reduced	–
P-R¹⁾	G354	Shielded	Reduced	–

Passivation

No code Not treated
CP55²⁾ Passivated corrosion-resistant steel

Oversize

No code Standard outer diameter size
RP01¹⁾ 0.010 in/0,254 mm oversized outer diameter
RP02¹⁾ 0.020 in/0,508 mm oversized outer diameter

1) SKF option

2) SKF option, available only for corrosion-resistant steel material without other surface treatment

Loads, clearance and torque

Nominal bore code	Static limit loads		Radial dynamic load rating ³⁾⁴⁾		Radial clearance		Axial clearance max	Maximum starting torque ⁵⁾	
	Radial C _s	Axial C _a	Load fixed with respect to outer ring inner ring		Standard	Reduced		Shielded	Sealed
–	lbf/kN		lbf/kN		in/mm		oz-in/mNm		
3L	550 2,45	100 0,45	550 2,45	480 2,14	0/0,0010 0/0,0254	0,0001/0,0005 0,0025/0,0127	0,023 0,584	0,67 4,71	1 7,06
3	900 4,00	200 0,89	900 4,00	770 3,43	0/0,0010 0/0,0254	0,0001/0,0005 0,0025/0,0127	0,023 0,584	0,67 4,71	1 7,06
4A	900 4,00	200 0,89	900 4,00	770 3,43	0/0,0010 0/0,0254	0,0001/0,0005 0,0025/0,0127	0,025 0,635	0,67 4,71	1 7,06
4	1 410 6,27	300 1,33	1 230 5,47	1 230 5,47	0/0,0010 0/0,0254	0,0001/0,0005 0,0025/0,0127	0,025 0,635	0,67 4,71	1 7,06
5A	1 000 4,45	200 0,89	950 4,23	815 3,63	0/0,0010 0/0,0254	0,0001/0,0005 0,0025/0,0127	0,028 0,711	1,33 9,41	2 14,12
5	2 190 9,74	300 1,33	2 190 9,74	1 890 8,41	0/0,0010 0/0,0254	0,0001/0,0005 0,0025/0,0127	0,028 0,711	1,33 9,41	2 14,12

3) For average life of 10 000 cycles at $\theta = 90^\circ$ oscillation, see page 38

4) If G395 load rating is 20% lower

5) Values are valid for bearings with G395. When using G354, values are 20% higher.

1.23 Self-aligning ball bearing single row (inch dimensions)

KSP., KSP..A, KSP..L bore code 6A to 10

Technical specification	AS 7949
Product standard	AS 27645

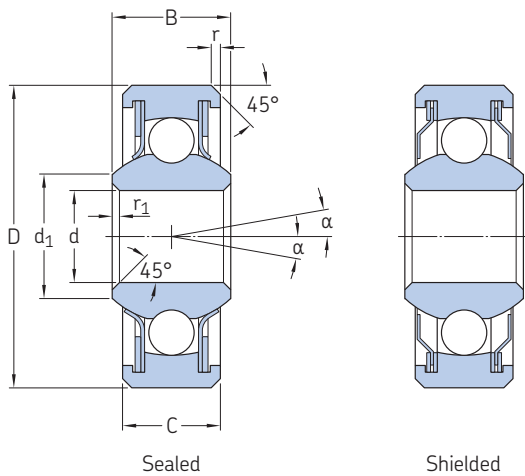

Dimensions

Nominal bore code	d	Δd_{mp}		Δd_s	D	ΔD_{mp}		ΔD_s	C	ΔC_s	
		Standard	SKF super precision			Standard	SKF super precision			Standard	SKF super precision
–	in/mm										
6A	0.3750 9,525	0/-0.0005 0/-0,0127	0/-0.0003 0/-0,0076	+0.0002/-0.0007 +0,0050/-0,0178	0.8750 22,225	0/-0.0005 0/-0,0127	0/-0.0004 0/-0,0101	+0.0005/-0.0010 +0,0127/-0,0254	0.250 6,350	0/-0.005 0/-0,127	0/-0.005 0/-0,127
6	0.3750 9,525	0/-0.0005 0/-0,0127	0/-0.0003 0/-0,0076	+0.0002/-0.0007 +0,0050/-0,0178	1.4375 36,513	0/-0.0005 0/-0,0127	0/-0.0004 0/-0,0101	+0.0005/-0.0010 +0,0127/-0,0254	0.469 11,913	0/-0.005 0/-0,127	0/-0.005 0/-0,127
8	0.5000 12,700	0/-0.0005 0/-0,0127	0/-0.0003 0/-0,0076	+0.0002/-0.0007 +0,0050/-0,0178	1.6875 42,862	0/-0.0005 0/-0,0127	0/-0.0004 0/-0,0101	+0.0005/-0.0010 +0,0127/-0,0254	0.500 12,700	0/-0.005 0/-0,127	0/-0.005 0/-0,127
10	0.6250 15,875	0/-0.0005 0/-0,0127	0/-0.0003 0/-0,0076	+0.0002/-0.0007 +0,0050/-0,0178	1.9375 49,212	0/-0.0005 0/-0,0127	0/-0.0004 0/-0,0101	+0.0005/-0.0010 +0,0127/-0,0254	0.625 15,875	0/-0.005 0/-0,127	0/-0.005 0/-0,127

Dimensions cont. and tolerances

Nominal bore code	B	ΔB_s		d_1	r_1	r	α	Mass	Tolerances		Kea max	SKF super precision	
		Standard	SKF super precision						Kia max Standard	SKF super precision			
–	in/mm							°	lb/g	in/mm			
6A	0.313 7,950	0/-0.005 0/-0,127	0/-0.0025 0/-0,0635	0.462 11,735	0.016 0,406	0.016 0,406	8	0.03 14	0.0010 0,0254	0.0005 0,0127	0.0016 0,0406	0.0008 0,0203	
6	0.620 15,748	0/-0.005 0/-0,127	0/-0.0025 0/-0,0635	0.612 15,545	0.015 0,381	0.032 0,813	10	0.15 68	0.0010 0,0254	0.0005 0,0127	0.0016 0,0406	0.0008 0,0203	
8	0.620 15,748	0/-0.005 0/-0,127	0/-0.0025 0/-0,0635	0.796 20,218	0.015 0,381	0.044 1,118	10	0.23 104	0.0010 0,0254	0.0005 0,0127	0.0016 0,0406	0.0008 0,0203	
10	0.813 20,650	0/-0.005 0/-0,127	0/-0.0025 0/-0,0635	0.922 23,418	0.015 0,381	0.044 1,118	10	0.37 168	0.0010 0,0254	0.0005 0,0127	0.0016 0,0406	0.0008 0,0203	



Designation system

Examples: ZWMKSP 6ASK1CP55RP01
KSP 3P

Material and surface treatment

No code Cadmium plated bearing steel
W¹⁾ Corrosion-resistant steel
S Zinc-nickel plated bearing steel
ZW¹⁾ Cadmium plated corrosion-resistant steel
SZW¹⁾ Zinc-nickel plated corrosion-resistant steel

Tolerances

No code Standard tolerances
M¹⁾ Reduced clearance and SKF super precision

Basic designation

Bore code (multiples of 1/16th inch)

Variation

	Lubricant	Shield and seal	Radial clearance KSP..	MKSP.. ¹⁾
SK1	G354	Sealed	Standard	Reduced
S181	G395	Sealed	Standard	Reduced
S181-R	G395	Sealed	Reduced	–
SK1-R	G354	Sealed	Reduced	–
P¹⁾	G354	Shielded	Standard	Reduced
PG81¹⁾	G395	Shielded	Standard	Reduced
PG81-R¹⁾	G395	Shielded	Reduced	–
P-R¹⁾	G354	Shielded	Reduced	–

Passivation

No code Not treated
CP55²⁾ Passivated corrosion-resistant steel

Oversize

No code Standard outer diameter size
RP01¹⁾ 0.010 in/0,254 mm oversized outer diameter
RP02¹⁾ 0.020 in/0,508 mm oversized outer diameter

1) SKF option

2) SKF option, available only for corrosion-resistant steel material without other surface treatment

Loads, clearance and torque

Nominal bore code	Static limit loads		Radial dynamic load rating ³⁾⁴⁾		Radial clearance		Axial clearance max	Maximum starting torque ⁵⁾	
	Radial C _s	Axial C _a	Load fixed with respect to outer ring inner ring		Standard	Reduced		Shielded	Sealed
–	lbf/kN				in/mm		oz-in/mNm		
6A	1 120	200	1 120	990	0/ 0,0010	0,0001/ 0,0005	0,03	2	3
	4,98	0,89	4,98	4,40	0/ 0,0254	0,0025/ 0,0127	0,762	14.12	21.18
6	2 980	400	2 980	2 580	0/ 0,0010	0,0001/ 0,0005	0,03	2	3
	13,26	1,78	13,26	11,48	0/ 0,0254	0,0025/ 0,0127	0,762	14.12	21.18
8	3 670	500	3 670	3 290	0/ 0,0010	0,0001/ 0,0005	0,032	2.67	4
	16,32	2,22	16,32	14,63	0/ 0,0254	0,0025/ 0,0127	0,813	18.83	28.25
10	5 320	600	4 980	4 360	0/ 0,0010	0,0001/ 0,0005	0,034	4	5
	23,66	2,67	22,15	19,39	0/ 0,0254	0,0025/ 0,0127	0,864	28.25	35,31

3) For average life of 10 000 cycles at $\theta = 90^\circ$ oscillation, see page 38

4) If G395 load rating is 20% lower

5) Values are valid for bearings with G395. When using G354, values are 20% higher

1.24 Self-aligning ball bearing single row (inch dimensions)

KSP..SP., KSP.A..SP..

Technical specification -
Product standard -

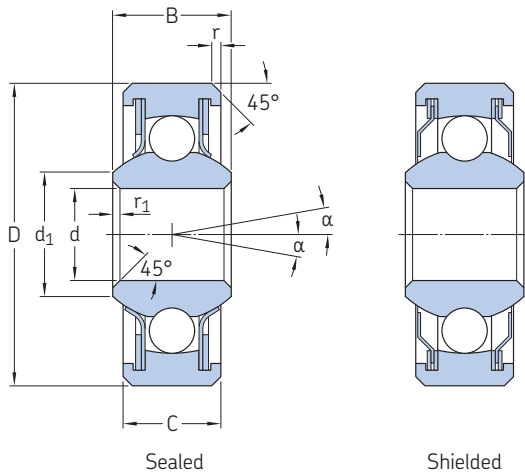

1.24



Dimensions, loads and clearance

Nominal bore code	Dimensions				d_1 ≈	r_1 Min	r Min	α	Mass ≈	Static limit load Radial C_5	Radial clearance
	d	D	C	B							
-	in/mm							°	lb/g	lbf/kN	in/mm
3..SP2	0.1898 4,821	0.7774 19,746	0.2700 6,858	0.2970 7,544	0.328 8,331	0.030 0,762	0.030 0,762	12	0.026 12	890 3,96	0/0.0005 0/0,0127
3A..SP3	0.1898 4,821	0.6250 15,875	0.2030 5,156	0.2450 6,223	0.257 6,528	0.015 0,381	0.015 0,381	10	0.011 5	540 2,40	0/0.0005 0/0,0127
3..SP4	0.1898 4,281	0,7774 19,746	0,2700 6,858	0,3750 9,525	0,298 7,569	0,005 0,127	0,022 0,559	7	0,026 12	890 3,96	0/0.0005 0/0,0127
4..SP1	0.2500 6,350	0.9014 22,896	0.3350 8,509	0.4840 12,294	0.410 10,414	0.040 1,016	0.040 1,016	12	0.042 19	1 390 6,18	0/0.0005 0/0,0127
5..SP3	0.3125 7,938	1.2500 31,750	0.3750 9,525	0.5575 14,160	0.563 14,300	0.040 1,016	0.040 1,016	10	0.104 47	2 170 9,65	0/0.0005 0/0,0127
5A..SP4	0.3125 7,938	0.8750 22,225	0.3125 7,938	0.6250 15,875	0.415 10,541	0.016 0,406	0.016 0,406	10	0.037 17	1 270 5,65	0/0.0005 0/0,0127
5A..SP5	0.3125 7,938	0.8750 22,225	0.3125 7,937	0.5200 13,208	0.415 10,541	0.016 0,406	0.016 0,406	10	0.035 16	1 270 5,65	0/0.0005 0/0,0127
6..SP1	0.3750 9,525	1.4375 36,513	0.4688 11,907	0.6200 15,748	0.688 17,475	0.040 1,016	0.040 1,016	10	0.156 71	3 550 15,79	0/0.0005 0/0,0127
6A..SP2	0.3748 9,520	0.8750 22,225	0.2500 6,350	0.3130 7,950	0.475 12,065	0.025 0,635	0.025 0,635	9	0.03 14	1 110 4,94	0/0.0007 0/0,0178
8..SP1	0.5000 12,700	1.6875 42,862	0.5000 12,700	0.6200 15,748	0.854 21,692	0.047 1,194	0.047 1,194	10	0.236 107	4 150 18,46	0/0.0007 0/0,0178
10..SP1	0.6250 15,875	1.9375 49,212	0.6250 15,875	0.8125 20,638	1.000 25,400	0.047 1,194	0.047 1,194	12	0.379 172	5 620 25,00	0/0.0007 0/0,0178



Designation system

Examples: ZWKSP 6APSP2G81CP55RP01
KSP10SP1

Material and surface treatment

No code	Cadmium plated bearing steel
W	Corrosion-resistant steel
S	Zinc-nickel plated bearing steel
ZW	Cadmium plated corrosion-resistant steel
SZW	Zinc-nickel plated corrosion-resistant steel

Basic designation

Bore code (multiples of 1/16th inch)

Shield and seal

No code	Sealed
P	Shielded

Lubricant

No code	Grease G354
G81	Grease G395

Passivation

No code	Not treated
CP55 ¹⁾	Passivated corrosion-resistant steel

Oversize

No code	Standard outer diameter size
RP01	0.010 in/0,254 mm oversized outer diameter
RP02	0.020 in/0,508 mm oversized outer diameter

¹⁾ Available only for corrosion-resistant steel material without other surface treatment

1.25 Self-aligning ball bearing double row (inch dimensions)

KN..

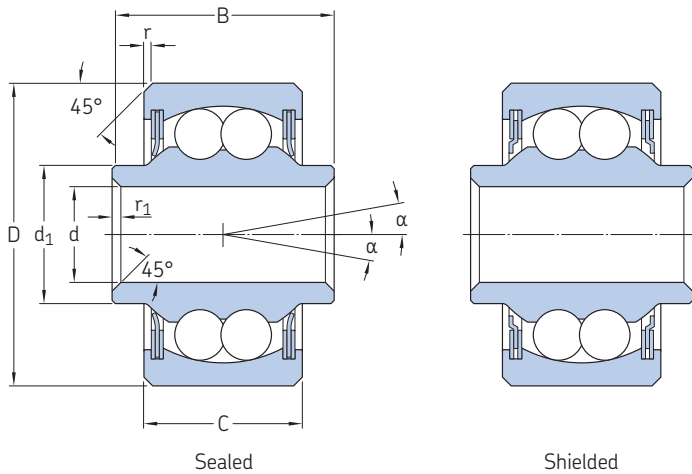

Technical specification	-
Product standard	-

Dimensions

Nominal Dimensions

bore code	d	Δdmp	D	ΔDmp	C	ΔCs	B	ΔBs	d ₁ ≈	r ₁ +0,012/-0,004 +0,300/-0,100	r +0,012/-0,004 +0,300/-0,100	α
-	in/mm											°
4,83	0.1900	0/-0.0005	0.6300	0/-0.0003	0.315	0/-0.0039	0.472	0/-0.0039	0.299	0.020	0.020	7
	4,826	0/-0,0127	16,000	0/-0,0080	8,000	0/-0,1000	12,000	0/-0,1000	7,595	0,500	0,500	
6,35	0.2500	0/-0.0005	0.7480	0/-0.00035	0.394	0/-0.0039	0.551	0/-0.0039	0.323	0.020	0.020	7
	6,350	0/-0,0127	19,000	0/-0,0090	10,000	0/-0,1000	14,000	0/-0,1000	8,204	0,500	0,500	
7,94	0.3125	0/-0.0005	0.9449	0/-0.00035	0.394	0/-0.0039	0.591	0/-0.0039	0.437	0.020	0.020	7
	7,938	0/-0,0127	24,000	0/-0,0090	10,000	0/-0,1000	15,000	0/-0,1000	11,100	0,500	0,500	
9,52	0.3750	0/-0.0005	1.1811	0/-0.00035	0.551	0/-0.0039	0.787	0/-0.0039	0.535	0.020	0.020	7
	9,525	0/-0,0127	30,000	0/-0,0090	14,000	0/-0,1000	20,000	0/-0,1000	13,589	0,500	0,500	
12,7	0.5000	0/-0.0005	1.2598	0/-0.00043	0.551	0/-0.0039	0.787	0/-0.0039	0.606	0.020	0.020	7
	12,700	0/-0,0127	32,000	0/-0,0110	14,000	0/-0,1000	20,000	0/-0,1000	15,392	0,500	0,500	
15,87	0.6250	0/-0.0005	1.3780	0/-0.00043	0.551	0/-0.0039	0.787	0/-0.0039	0.728	0.020	0.020	7
	15,875	0/-0,0127	35,000	0/-0,0110	14,000	0/-0,1000	20,000	0/-0,1000	18,491	0,500	0,500	

Tolerances, loads, clearance and torque

Nominal bore code	Mass ≈	Tolerances		Static limit loads		Clearances		Maximum starting torque		Max. swivelling torque
		Kia max	Kea max	Radial C _s	Axial C _a	Axial Max	Radial Max	Shielded	Sealed	
-	lb/g	in/mm		lbf/kN		in/mm		oz-in/mNm		
4,83	0.020	0.0010	0.0016	877	270	0.0028	0.00024	0.566	1.133	14.2
	9	0,025	0,040	3,90	1,20	0,0700	0,0060	4,00	8,00	0,10
6,35	0.031	0.0010	0.0016	1 326	405	0.0028	0.00024	0.637	1.274	14.2
	14	0,025	0,040	5,90	1,80	0,0700	0,0060	4,50	9,00	0,10
7,94	0.066	0.0010	0.0016	2 203	674	0.0031	0.00028	0.779	1.416	14.2
	30	0,025	0,040	9,80	3,00	0,0800	0,0070	5,50	10,00	0,10
9,52	0.126	0.0010	0.0016	3 192	1 012	0.0031	0.00028	1.062	1.699	14.2
	57	0,025	0,040	14,20	4,50	0,0800	0,0070	7,50	12,00	0,10
12,7	0.137	0.0010	0.0016	3 754	1 169	0.0031	0.00035	1.274	1.983	14.2
	62	0,025	0,040	16,70	5,20	0,0800	0,0090	9,00	14,00	0,10
15,87	0.165	0.0010	0.0016	4 272	1 326	0.0031	0.00035	1.699	2.549	14.2
	75	0,025	0,040	19,00	5,90	0,0800	0,0090	12,00	18,00	0,10



Designation system

Examples:	ZWKN 6,35SK1CP55RP01 KN12,7	Z	W	KN	6,35	SK1	CP55	RP01
Surface treatment								
No code	Not plated steel							
Z	Cadmium plated steel							
SZ	Zinc-nickel plated steel							
Material								
No code	Bearing steel							
W	Corrosion-resistant steel							
Basic designation								
Bore code (multiples of 1/16 th inch)								
Variation								
	Lubricant							
No code	G354							
G81	G395							
S181	G395							
SK1	G354							
	Version							
No code								
G81								
S181								
SK1								
Passivation								
No code	Not treated							
CP55¹⁾	Passivated corrosion-resistant steel							
Oversize								
No code	Standard outer diameter size							
RP01	0.010 in/0,254 mm oversized outer diameter							
RP02	0.020 in/0,508 mm oversized outer diameter							

1) Available only for corrosion-resistant steel material without other surface treatment

1.26 Self-aligning ball bearing double row (inch dimensions)

DSP..

Technical specification	AS 7949
Product standard	AS 27643

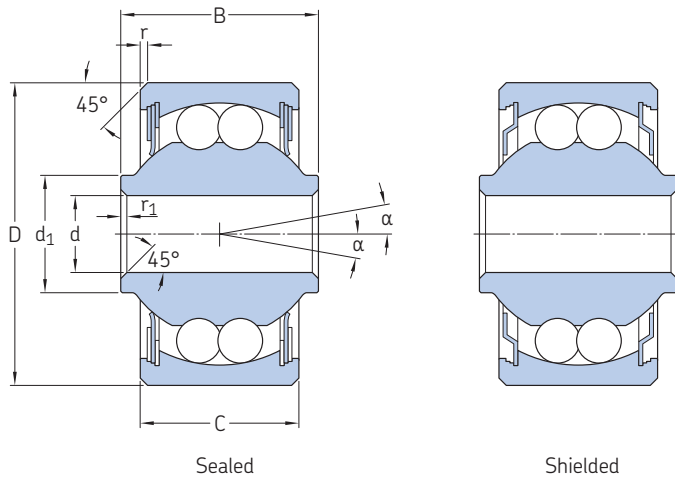

1.26

Dimensions

Nominal bore code	d	Δdmp		Δds	D	ΔDmp		ΔDs	C	ΔCs		
		Standard	SKF super precision			Standard	SKF super precision			Standard	SKF super precision	
in/mm												
3	0.1900	0/-0.0005	0/-0.0003	+0.0002/-0.0007	0.7774	0/-0.0005	0/-0.0004	+0.0005/-0.0010	0.392	0/-0.005	0/-0.005	
	4,826	0/-0,0127	0/-0,0076	+0,0050/-0,0178	19,745	0/-0,0127	0/-0,0101	+0,0127/-0,0254	9,957	0/-0,127	0/-0,127	
4	0.2500	0/-0.0005	0/-0.0003	+0.0002/-0.0007	0.9014	0/-0.0005	0/-0.0004	+0.0005/-0.0010	0.464	0/-0.005	0/-0.005	
	6,350	0/-0,0127	0/-0,0076	+0,0050/-0,0178	22,895	0/-0,0127	0/-0,0101	+0,0127/-0,0254	11,785	0/-0,127	0/-0,127	
5	0.3125	0/-0.0005	0/-0.0003	+0.0002/-0.0007	1.2500	0/-0.0005	0/-0.0004	+0.0005/-0.0010	0.656	0/-0.005	0/-0.005	
	7,938	0/-0,0127	0/-0,0076	+0,0050/-0,0178	31,750	0/-0,0127	0/-0,0101	+0,0127/-0,0254	16,662	0/-0,127	0/-0,127	
6	0.3750	0/-0.0005	0/-0.0003	+0.0002/-0.0007	1.4375	0/-0.0005	0/-0.0004	+0.0005/-0.0010	0.750	0/-0.005	0/-0.005	
	9,525	0/-0,0127	0/-0,0076	+0,0050/-0,0178	36,513	0/-0,0127	0/-0,0101	+0,0127/-0,0254	19,050	0/-0,127	0/-0,127	
8	0.5000	0/-0.0005	0/-0.0003	+0.0002/-0.0007	1.6875	0/-0.0005	0/-0.0004	+0.0005/-0.0010	0.812	0/-0.005	0/-0.005	
	12,700	0/-0,0127	0/-0,0076	+0,0050/-0,0178	42,862	0/-0,0127	0/-0,0101	+0,0127/-0,0254	20,624	0/-0,127	0/-0,127	
10	0.6250	0/-0.0005	0/-0.0003	+0.0002/-0.0007	1.9375	0/-0.0005	0/-0.0004	+0.0005/-0.0010	0.937	0/-0.005	0/-0.005	
	15,875	0/-0,0127	0/-0,0076	+0,0050/-0,0178	49,212	0/-0,0127	0/-0,0101	+0,0127/-0,0254	23,799	0/-0,127	0/-0,127	

Dimensions cont. and tolerances

Nominal bore code	Dimensions		d ₁	r ₁	r	α	Mass	Tolerances		Kea max	SKF super precision	
	B	ΔBs						Kia max	Standard			
in/mm												
3	0.500	0/-0.005	0.304	0.005	0.022	10	0,04	0.0010	0.0005	0.0016	0.0008	
	12,700	0/-0,127	7,721	0,127	0,559	10	18	0,0254	0,0127	0,0406	0,0203	
4	0.687	0/-0.005	0.430	0.005	0.032	10	0,06	0.0010	0.0005	0.0016	0.0008	
	17,449	0/-0,127	10,922	0,127	0,813	10	27	0,0254	0,0127	0,0406	0,0203	
5	0.812	0/-0.005	0.515	0.015	0.032	10	0,16	0.0010	0.0005	0.0016	0.0008	
	20,624	0/-0,127	13,081	0,381	0,813	10	73	0,0254	0,0127	0,0406	0,0203	
6	0.937	0/-0.005	0.564	0.015	0.032	10	0,24	0.0010	0.0005	0.0016	0.0008	
	23,799	0/-0,127	14,325	0,381	0,813	10	109	0,0254	0,0127	0,0406	0,0203	
8	1.000	0/-0.005	0.775	0.015	0.044	10	0,36	0.0010	0.0005	0.0016	0.0008	
	25,400	0/-0,127	19,685	0,381	1,118	10	163	0,0254	0,0127	0,0406	0,0203	
10	1.125	0/-0.005	0.869	0.015	0.044	10	0,53	0.0010	0.0005	0.0016	0.0008	
	28,575	0/-0,127	22,072	0,381	1,118	10	240	0,0254	0,0127	0,0406	0,0203	



Designation system

Examples: ZW M DSP 10 SK1 CP55 RP01
 DSP 4P

Material and surface treatment

No code Cadmium plated bearing steel
W¹⁾ Corrosion-resistant steel
S Zinc-nickel plated bearing steel
ZW¹⁾ Cadmium plated corrosion-resistant steel
SZW¹⁾ Zinc-nickel plated corrosion-resistant steel

Tolerances

No code Standard tolerances
M¹⁾ Reduced clearance and SKF super precision

Basic designation

Bore code (multiples of 1/16th inch)

Variation

	Lubricant	Version	Radial clearance DSP..	MDSP.. ¹⁾
SK1	G354	Sealed	Standard	Reduced
S181	G395	Sealed	Standard	Reduced
S181-R	G395	Sealed	Reduced	–
SK1-R	G354	Sealed	Reduced	–
P¹⁾	G354	Shielded	Standard	Reduced
PG81¹⁾	G395	Shielded	Standard	Reduced
PG81-R¹⁾	G395	Shielded	Reduced	–
P-R¹⁾	G354	Shielded	Reduced	–

Passivation

No code Not treated
CP55²⁾ Passivated corrosion-resistant steel

Oversize

No code Standard outer diameter size
RP01¹⁾ 0.010 in/0,254 mm oversized outer diameter
RP02¹⁾ 0.020 in/0,508 mm oversized outer diameter

1) SKF option

2) SKF option, available only for corrosion-resistant steel material without other surface treatment

Tolerances cont., loads, clearance and torque

Nominal bore code	Static limit loads		Radial dynamic load rating ³⁾⁴⁾		Radial clearance		Axial clearance max	Maximum starting torque ⁵⁾	
	Radial C _s	Axial C _a	Load fixed with respect to outer ring inner ring		Standard	Reduced		Shielded	Sealed
–	lbf/kN		lbf/kN		in/mm		oz.in/mNm		
3	1 420	200	1 420	1 220	0/ 0,0010	0,0002/ 0,0005	0,0055	0,67	1
	6,32	0,89	6,32	5,43	0/ 0,0254	0,0051/ 0,0127	0,140	4,71	7,06
4	1 780	300	1 780	1 600	0/ 0,0010	0,0002/ 0,0005	0,0055	0,67	1
	7,92	1,33	7,92	7,12	0/ 0,0254	0,0051/ 0,0127	0,140	4,71	7,06
5	3 740	600	3 470	3 300	0/ 0,0010	0,0002/ 0,0005	0,006	1,33	3
	16,64	2,67	15,44	14,68	0/ 0,0254	0,0051/ 0,0127	0,152	9,41	21,18
6	5 100	800	4 980	4 370	0/ 0,0010	0,0002/ 0,0005	0,006	1,33	4
	22,69	3,56	22,15	19,44	0/ 0,0254	0,0051/ 0,0127	0,152	9,41	28,25
8	7 120	1 000	6 340	5 570	0/ 0,0010	0,0002/ 0,0005	0,007	1,33	5
	31,67	4,45	28,20	24,78	0/ 0,0254	0,0051/ 0,0127	0,178	9,41	35,31
10	9 000	1 300	7 780	6 860	0/ 0,0010	0,0002/ 0,0005	0,007	2	6
	40,03	5,78	34,61	30,51	0/ 0,0254	0,0051/ 0,0127	0,178	14,12	42,37

3) For average life of 10 000 cycles at $\theta = 90^\circ$ oscillation, see page 38

4) If G395 load rating is 20% lower

5) Values are valid for bearings with G395. When using G354, values are 20% higher

1.27 Spherical roller bearing single row (inch dimensions)

DSRP..

Technical specification	-
Product standard	-

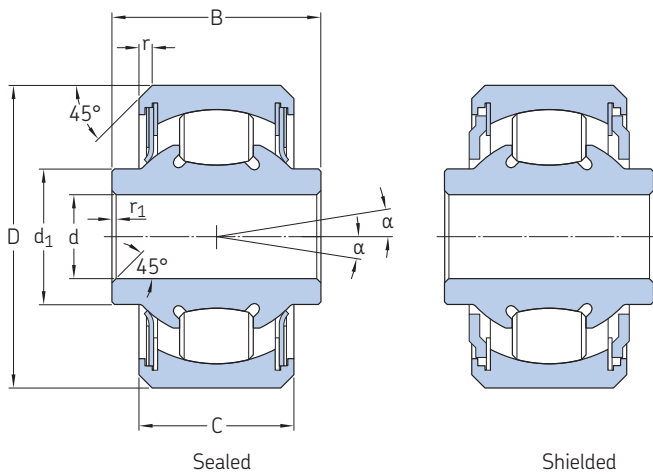

Dimensions

Nominal Dimensions

bore code	d	Δd_{mp}	D	ΔD_{mp}	C	ΔC_s	B	ΔB_s	$d_1 =$	r_1 +0,015/0 +0,381/0	r +0,015/0 +0,381/0	α
-	in/mm											
4	0.2500 6,350	0/-0.0005 0/-0,0127	0.9014 22,895	0/-0.0005 0/-0,0127	0.464 11,785	0/-0.005 0/-0,127	0.625 15,875	0/-0.005 0/-0,127	0.404 10,260	0.005 0,127	0.032 0,813	10
5	0.3125 7,938	0/-0.0005 0/-0,0127	1.2500 31,750	0/-0.0005 0/-0,0127	0.656 16,662	0/-0.005 0/-0,127	0.812 20,624	0/-0.005 0/-0,127	0.515 13,081	0.015 0,381	0.032 0,813	10
6	0.3750 9,525	0/-0.0005 0/-0,0127	1.4375 36,513	0/-0.0005 0/-0,0127	0.750 19,050	0/-0.005 0/-0,127	0.937 23,799	0/-0.005 0/-0,127	0.564 14,325	0.015 0,381	0.032 0,813	10
8	0.5000 12,700	0/-0.0005 0/-0,0127	1.6875 42,862	0/-0.0005 0/-0,0127	0.812 20,624	0/-0.005 0/-0,127	1.000 25,400	0/-0.005 0/-0,127	0.775 19,685	0.015 0,381	0.044 1,118	10
10	0.6250 15,875	0/-0.0005 0/-0,0127	1.9375 49,212	0/-0.0005 0/-0,0127	0.937 23,799	0/-0.005 0/-0,127	1.125 28,575	0/-0.005 0/-0,127	0.869 22,072	0.015 0,381	0.044 1,118	10
12	0.7500 19,050	0/-0.0005 0/-0,0127	2.3750 60,325	0/-0.0005 0/-0,0127	1.125 28,580	0/-0.005 0/-0,127	1.312 33,325	0/-0.005 0/-0,127	1.150 29,210	0.015 0,381	0.044 1,118	10

Tolerances, loads and clearance

Nominal bore code	Mass \approx	Tolerances		Static limit loads		Radial clearance
		Kia max	Kea max	Radial C_s	Axial C_a	
-	lb/g	in/mm		lbf/kN		in/mm
4	0.06 27	0.0010 0,0254	0.0016 0,0406	3 025 13,46	907,50 4,04	0.0004/0.0010 0,0101/0,0254
5	0.16 73	0.0010 0,0254	0.0016 0,0406	7 350 32,69	2 205 9,81	0.0004/0.0010 0,0101/0,0254
6	0.24 109	0.0010 0,0254	0.0016 0,0406	9 600 42,70	2 880 12,81	0.0004/0.0010 0,0101/0,0254
8	0.36 163	0.0010 0,0254	0.0016 0,0406	12 500 55,60	3 750 16,68	0.0004/0.0010 0,0101/0,0254
10	0.55 249	0.0010 0,0254	0.0016 0,0406	17 700 78,73	5 310 23,62	0.0004/0.0010 0,0101/0,0254
12	1.05 476	0.0010 0,0254	0.0016 0,0460	26 900 119,67	8 070 35,90	0.0004/0.0010 0,0101/0,0254



Designation system

Examples: ZWDSRP10SK1CP55RP01
DSRP 4P

ZW DSRP 10 SK1 CP55 RP01

Material and surface treatment

No code	Cadmium plated bearing steel
W	Corrosion-resistant steel
S	Zinc-nickel plated bearing steel
ZW	Cadmium plated corrosion-resistant steel
SZW	Zinc-nickel plated corrosion-resistant steel

Basic designation

Bore code (multiples of 1/16th inch)

Variation

	Lubricant	Version
SK1	G354	Sealed
S181	G395	Sealed
PG81	G395	Shielded
P	G354	Shielded

Passivation

No code	Not treated
CP55 ¹⁾	Passivated corrosion-resistant steel

Oversize

No code	Standard outer diameter size
RP01	0.010 in/0,254 mm oversized outer diameter
RP02	0.020 in/0,508 mm oversized outer diameter

¹⁾ Available only for corrosion-resistant steel material without other surface treatment

Cross-reference

Metric bearings

1

EN part number	SKF designation
EN3045Ad'P	JNA d DN744
EN3045Ad'E	JNA d EDN744
EN3045Bd'P	JNA d DN814
EN3045Bd'E	JNA d EDN814
EN3046Ad'P	ZJNA d DN744
EN3046Ad'E	ZJNA d EDN744
EN3046Bd'P	ZJNA d DN814
EN3046Bd'E	ZJNA d EDN814
EN3047Ad'P	WJNA d DN744
EN3047Ad'E	WJNA d EDN744
EN3047Bd'P	WJNA d DN814
EN3047Bd'E	WJNA d EDN814
EN3284Ad'P	JNA d N743
EN3284Ad'E	JNA d EN743
EN3284Bd'P	JNA d N813
EN3284Bd'E	JNA d EN813
EN3285Ad'P	ZJNA d N743
EN3285Ad'E	ZJNA d EN743
EN3285Bd'P	ZJNA d N813
EN3285Bd'E	ZJNA d EN813
EN3286Ad'P	WJNA d N743
EN3286Ad'E	WJNA d EN743
EN3286Bd'P	WJNA d N813
EN3286Bd'E	WJNA d EN813

Where
d = Bore code
d' = d with a 0 replacing the space for d ≤ 8
d for d ≥ 10

Example

EN part number	SKF designation
EN3045A 06 P	JNA 6 DN744
EN3046A 10 E	ZJNA 10 EDN744
EN3284B 15 P	JNA 15 N813
EN3286B 25 E	WJNA 25 EN813

EN part number	SKF designation
EN4033AdP	WATA d N745
EN4033AdE	WATA d EN745
EN4033BdP	WATA d N815
EN4033BdE	WATA d EN815
EN4033AdPT	WATA d N745CP55
EN4033AdET	WATA d EN745CP55
EN4033BdPT	WATA d N815CP55
EN4033BdET	WATA d EN815CP55
EN3281AdP	TA d N743
EN3281AdE	TA d EN743
EN3281BdP	TA d N813
EN3281BdE	TA d EN813
EN3282AdP	ZTA d N743
EN3282AdE	ZTA d EN743
EN3282BdP	ZTA d N813
EN3282BdE	ZTA d EN813
EN3283AdP	WATA d N743
EN3283AdE	WATA d EN743
EN3283BdP	WATA d N813
EN3283BdE	WATA d EN813

Where
d = Bore code

Example

EN part number	SKF designation
EN4033B 10 P	WATA 10 N815
EN4033B 17 PT	WATA 17 N815CP55
EN3281A 25 E	TA 25 EN743
EN3283B 40 E	WATA 40 EN813

EN part number	SKF designation
EN3056Ad'P	AGNd
EN3056Ad'E	AGNdE
EN3056Bd'P	AGNdG81
EN3056Bd'E	AGNdEG81
EN3057Ad'P	ZAGNd
EN3057Ad'E	ZAGNdE
EN3057Bd'P	ZAGNdG81
EN3057Bd'E	ZAGNdEG81
EN3058Ad'P	WAGNd
EN3058Ad'E	WAGNdE
EN3058Bd'P	WAGNdG81
EN3058Bd'E	WAGNdEG81

Where

d = Bore code

d' = d with a 0 replacing the space for d = 8
d for d ≥ 10

Example

EN part number	SKF designation
EN3056A 08 P	AGN 8
EN3057B 12 P	ZAGN 12 G81
EN3058B 20 E	WAGN 20 EG81

EN part number	SKF designation
EN3059AdPC	TRCE d TN741
EN3059AdPD	TRCE d TCN741
EN3059AdEC	TRCE d EN741
EN3059AdED	TRCE d ECN741
EN3059BdPC	TRCE d TN811
EN3059BdPD	TRCE d TCN811
EN3059BdEC	TRCE d EN811
EN3059BdED	TRCE d ECN811
EN3060AdPC	ZTRCE d TN741
EN3060AdPD	ZTRCE d EN741
EN3060AdED	ZTRCE d ECN741
EN3060BdPC	ZTRCE d TN811
EN3060BdPD	ZTRCE d TCN811
EN3060BdEC	ZTRCE d EN811
EN3060BdED	ZTRCE d ECN811
EN3061AdPC	XTRCE d TN741
EN3061AdPD	XTRCE d TCN741
EN3061AdEC	XTRCE d EN741
EN3061AdED	XTRCE d ECN741
EN3061BdPC	XTRCE d TN811
EN3061BdPD	XTRCE d TCN811
EN3061BdEC	XTRCE d EN811
EN3061BdED	XTRCE d ECN811
EN3061AdPCT	XTRCE d TN741CP55
EN3061AdPDT	XTRCE d TCN741CP55
EN3061AdECT	XTRCE d EN741CP55
EN3061AdEDT	XTRCE d ECN741CP55
EN3061BdPCT	XTRCE d TN811CP55
EN3061BdPDT	XTRCE d TCN811CP55
EN3061BdECT	XTRCE d EN811CP55
EN3061BdEDT	XTRCE d ECN811CP55

Where

d = Bore code

Example

EN part number	SKF designation
EN3059A 16 PC	TRCE 16 TN741
EN3060A 25 ED	ZTRCE 25 ECN741
EN3061B 40 PD	XTRCE 40 TCN811
EN3061B 50 PDT	XTRCE 50 TCN811CP55

Metric bearings

1

EN part number	SKF designation
EN4041AdPC	XTRCEIdTN741
EN4041AdPD	XTRCEIdTCN741
EN4041AdEC	XTRCEIdEN741
EN4041AdED	XTRCEIdECN741
EN4041BdPC	XTRCEIdTN811
EN4041BdPD	XTRCEIdTCN811
EN4041BdEC	XTRCEIdEN811
EN4041BdED	XTRCEIdECN811
EN4041AdPCT	XTRCEIdTN741CP55
EN4041AdPDT	XTRCEIdTCN741CP55
EN4041AdECT	XTRCEIdEN741CP55
EN4041AdEDT	XTRCEIdECN741CP55
EN4041BdPCT	XTRCEIdTN811CP55
EN4041BdPDT	XTRCEIdTCN811CP55
EN4041BdECT	XTRCEIdEN811CP55
EN4041BdEDT	XTRCEIdECN811CP55

Where
d = Bore code

Example

EN part number	SKF designation
EN4041A 35 PC	XTRCEI 35 TN741
EN4041A 45 PCT	XTRCEI 45 TN741CP55

EN part number	SKF designation
EN4034AdP	WKNRCEdN743 ¹⁾
EN4034AdE	WKNRCEdEN743 ¹⁾
EN4034BdP	WKNRCEdN813 ¹⁾
EN4034BdE	WKNRCEdEN813 ¹⁾
EN4034AdPT	WKNRCEdN743CP55 ¹⁾
EN4034AdET	WKNRCEdEN743CP55 ¹⁾
EN4034BdPT	WKNRCEdN813CP55 ¹⁾
EN4034BdET	WKNRCEdEN813CP55 ¹⁾

Where
d = Bore code
¹⁾ Except for d = 35 and d = 40

Example

EN part number	SKF designation
EN4034A 16 P	WKNRCE 16 N743
EN4034A 16 PT	WKNRCE 16 N743CP55

EN part number	SKF designation
EN3287ARdP	KNd'N745
EN3287ARdE	KNdEN745
EN3287ANdP	KNd'N743
EN3287ANdE	KNdEN743
EN3287ALdP	KNd'N746
EN3287ALdE	KNdEN746
EN3287BRdP	KNd'N815
EN3287BRdE	KNdEN815
EN3287BNdP	KNd'N813
EN3287BNdE	KNdEN813
EN3287BLdP	KNd'N816
EN3287BLdE	KNdEN816
EN3288ARdP	ZKNd'N745
EN3288ARdE	ZKNdEN745
EN3288ANdP	ZKNd'N743
EN3288ANdE	ZKNdEN743
EN3288ALdP	ZKNd'N746
EN3288ALdE	ZKNdEN746
EN3288BRdP	ZKNd'N815
EN3288BRdE	ZKNdEN815
EN3288BNdP	ZKNd'N813
EN3288BNdE	ZKNdEN813
EN3288BLdP	ZKNd'N816
EN3288BLdE	ZKNdEN816
EN3289ARdP	WKNd'N745
EN3289ARdE	WKNdEN745
EN3289ANdP	WKNd'N743
EN3289ANdE	WKNdEN743
EN3289ALdP	WKNd'N746
EN3289ALdE	WKNdEN746
EN3289BRdP	WKNd'N815
EN3289BRdE	WKNdEN815
EN3289BNdP	WKNd'N813
EN3289BNdE	WKNdEN813
EN3289BLdP	WKNd'N816
EN3289BLdE	WKNdEN816

Where
d = Bore code
d' = d with a 0 replacing the space for d ≤ 6
8/24 for d = 8
d for d ≥ 10

Example

EN part number	SKF designation
EN3287AR 05 P	KN 5 N745
EN3288AL 10 E	ZKN 10 EN746
EN3289BN 17 P	WKN 17 N813

EN part number	SKF designation
EN3053Ad'P	KdFN743 KNdFN743 (For d = 12 and d = 15)
EN3053Ad'P1	KNdFN743 (Except for d = 12 and d = 15)
EN3053Bd'P	KdFN813 KNdFN813 (For d = 12 and d = 15)
EN3053Bd'P1	KNdFN813 (Except for d = 12 and d = 15)
EN3054Ad'P	ZKdFN743 ZKNdFN743 (For d = 12 and d = 15)
EN3054Ad'P1	ZKNdFN743 (Except for d = 12 and d = 15)
EN3054Bd'P	ZKdFN813 ZKNdFN813 (For d = 12 and d = 15)
EN3054Bd'P1	ZKNdFN813 (Except for d = 12 and d = 15)
EN3055Ad'P	WKdFN743 WKNdFN743 (For d = 12 and d = 15)
EN3055Ad'P1	WKNdFN743 (Except for d = 12 and d = 15)
EN3055Bd'P	WKdFN813 WKNdFN813 (For d = 12 and d = 15)
EN3055Bd'P1	WKNdFN813 (Except for d = 12 and d = 15)

Where

d = Bore code

d' = d with a 0 replacing the space for $d \leq 8$
d for $d \geq 10$

Example

EN part number	SKF designation
EN3053A 10 P	K 10 FN743
EN3053A 12 P	KN 12 FN743
EN3053A 10 P1	KN 10 FN743
EN3054B 06 P	ZK 6 FN813
EN3054B 15 P	ZKN 15 FN813
EN3054B 10 P1	ZKN 10 FN813
EN3055A 08 P	WK 8 FN743
EN3055A 12 P	WKN 12 FN743
EN3055A 10 P1	WKN 10 FN743

EN part number	SKF designation
EN3290AKd'P	KNA d FN743
EN3290AKd'E	KNA d FN743
EN3290ARd'P	KNA d FN745
EN3290ARd'E	KNA d FEN745
EN3290BKd'P	KNA d FN813
EN3290BKd'E	KNA d FEN813
EN3290BRd'P	KNA d FN815
EN3290BRd'E	KNA d FEN815
EN3291AKd'P	ZKNA d FN743
EN3291AKd'E	ZKNA d FEN743
EN3291ARd'P	ZKNA d FN745
EN3291ARd'E	ZKNA d FEN745
EN3291BKd'P	ZKNA d FN813
EN3291BKd'E	ZKNA d FEN813
EN3291BRd'P	ZKNA d FN815
EN3291BRd'E	ZKNA d FEN815
EN3292AKd'P	WKN d FN743
EN3292AKd'E	WKN d FEN743
EN3292ARd'P	WKN d FN745
EN3292ARd'E	WKN d FEN745
EN3292BKd'P	WKN d FN813
EN3292BKd'E	WKN d FEN813
EN3292BRd'P	WKN d FN815
EN3292BRd'E	WKN d FEN815

Where

d = Bore code

d' = d with a 0 replacing the space for $d = 8$
d for $d \geq 10$

Example

EN part number	SKF designation
EN3290AK 10 P	KNA 10 FN743
EN3291AR 17 P	ZKNA 17 FN745
EN3292BR 20 E	WKN 20 FEN815

Inch bearings

1

AS part number	SKF designation
MS27640- d 'GE	SKP d SK2
MS27640- d 'G	KP d SK2
MS27640- d 'E	SKP d S281
MS27640- d '	KP d S281
MS27640- d 'RGE	SKP d SK2-R
MS27640- d 'RG	KP d SK2-R
MS27640- d 'RE	SKP d S281-R
MS27640- d 'R	KP d S281-R
MS27640-3AGE	SKP 3LSK2
MS27640-3AG	KP 3LSK2
MS27640-3AE	SKP 3LS281
MS27640-3A	KP 3LS281
MS27640-3ARGE	SKP 3LSK2-R
MS27640-3ARG	KP 3LSK2-R
MS27640-3ARE	SKP 3LS281-R
MS27640-3AR	KP 3LS281-R

Where
d = Bore code
d' = d without space for $d \leq 8$
d for $d \geq 10$

Example

AS part number	SKF designation
MS27640- 5 GE	SKP 5 SK2
MS27640- 3 ARGE	SKP 3 LSK2-R

AS part number	SKF designation
MS27641- d 'GE	SKP d ASK2
MS27641- d 'G	KP d ASK2
MS27641- d 'E	SKP d S281
MS27641- d '	KP d S281
MS27641- d 'RGE	SKP d ASK2-R
MS27641- d 'RG	KP d ASK2-R
MS27641- d 'RE	SKP d AS281-R
MS27641- d 'R	KP d AS281-R

Where
d = Bore code
d' = d without space for $d \leq 8$
d for $d \geq 10$

Example

AS part number	SKF designation
MS27641- 10 RGE	SKP 10 ASK2-R

AS part number	SKF designation
MS27642- d GE	SKP d BSK2
MS27642- d G	KP d BSK2
MS27642- d E	SKP d S281
MS27642- d	KP d S281
MS27642- d SGE	SMKP d BSK2
MS27642- d SG	MKP d BSK2
MS27642- d SE	SMKP d S281
MS27642- d S	MKP d S281

Where
d = Bore code

Example

AS part number	SKF designation
MS27642- 23 SGE	SMKP 23 BSK2

AS part number	SKF designation
MS27646- d GE	SB5 d DDSK2
MS27646- d G	B5 d DDSK2
MS27646- d E	SB5 d DDS281
MS27646- d	B5 d DDS281
MS21428- d GE	SMB5 d DDSK2
MS21428- d G	MB5 d DDSK2
MS21428- d E	SMB5 d DDS281
MS21428- d	MB5 d DDS281

Where
5**d** = Bore code from product B500 **page 92**

Example

AS part number	SKF designation
MS27646- 40 GE	SB5 40 DDSK2
MS21428- 44	MB5 44 DDS281

AS part number	SKF designation
MS27644- d 'GE	SDPP d SK2
MS27644- d 'G	DPP d SK2
MS27644- d 'E	SDPP d S281
MS27644- d '	DPP d S281

Where
d = Bore code
d' = d without space for $d \leq 8$
d for $d \geq 10$

Example

AS part number	SKF designation
MS27644- 6 GE	SDPP 6 SK2

AS part number	SKF designation
MS27647- d 'RLE ¹⁾	SDW d SK2-R ¹⁾
MS27647- d 'RL ¹⁾	DW d SK2-R ¹⁾
MS27647- d 'RE ¹⁾	SDW d S281-R ¹⁾
MS27647- d 'R ¹⁾	DW d S281-R ¹⁾
MS27647- d 'LE ¹⁾	SDW d SK2 ¹⁾
MS27647- d 'L ¹⁾	DW d SK2 ¹⁾
MS27647- d 'E ¹⁾	SDW d S281 ¹⁾
MS27647- d ' ¹⁾	DW d S281 ¹⁾
MS27647-4RLE	SDW 4KSK2-R
MS27647-4RL	DW 4KSK2-R
MS27647-4RE	SDW 4KS281-R
MS27647-4R	DW 4KS281-R
MS27647-4LE	SDW 4KSK2
MS27647-4L	DW 4KSK2
MS27647-4E	SDW 4KS281
MS27647-4	DW 4KS281
MS27647-4ARLE	SDW 4K2SK2-R
MS27647-4ARL	DW 4K2SK2-R
MS27647-4ARE	SDW 4K2S281-R
MS27647-4AR	DW 4K2S281-R
MS27647-4ALE	SDW 4K2SK2
MS27647-4AL	DW 4K2SK2
MS27647-4AE	SDW 4K2S281
MS27647-4A	DW 4K2S281

Where
d = Bore code
d' = d without space
1) Except for **d** = 4

Example

AS part number	SKF designation
MS27647- 5 RLE	SDW 5 SK2-R
MS27647- 4	DW 4 KS281
MS27647- 4 AE	SDW 4 K2S281

Inch bearings

1

AS part number	SKF designation
MS27648- d GE	SKP d BSSK2
MS27648- d G	KP d BSSK2
MS27648- d E	SKP d BSS281
MS27648- d	KP d BSS281

Where
d = Bore code

Example

AS part number	SKF designation
MS27648- 21 GE	SKP 21 BSSK2

AS part number	SKF designation
MS27645- d 'RGE	SKSP d SK2-R
MS27645- d 'RG	KSP d SK2-R
MS27645- d 'RE	SKSP d S181-R
MS27645- d 'R	KSP d S181-R
MS27645- d 'GE	SKSP d SK2
MS27645- d 'G	KSP d SK2
MS27645- d 'E	SKSP d S181
MS27645- d '	KSP d S181
MS27645- d 'ARGE ¹⁾	SKSP d ASK2-R
MS27645- d 'ARG ¹⁾	KSP d ASK2-R
MS27645- d 'ARE ¹⁾	SKSP d AS181-R
MS27645- d 'AR ¹⁾	KSP d AS181-R
MS27645- d 'AGE ¹⁾	SKSP d ASK2
MS27645- d 'AG ¹⁾	KSP d ASK2
MS27645- d 'AE ¹⁾	SKSP d AS181
MS27645- d 'A ¹⁾	KSP d AS181
MS27645-3ARGE	SKSP 3LSK2-R
MS27645-3ARG	KSP 3LSK2-R
MS27645-3ARE	SKSP 3LS181-R
MS27645-3AR	KSP 3LS181-R
MS27645-3AGE	SKSP 3LSK2
MS27645-3AG	KSP 3LSK2
MS27645-3AE	SKSP 3LS181
MS27645-3A	KSP 3LS181

Where
d = Bore code
d' = d without space for $d \leq 8$
d for $d \geq 10$
¹⁾ Except for $d = 3$

Example

AS part number	SKF designation
MS27645- 8 RGE	SKSP 8 SK2-R
MS27645- 5 AGE	SKSP 5 ASK2
MS27645- 3 AG	KSP 3 LSK2

AS part number	SKF designation
MS27643- d 'RGE	SDSP d SK1-R
MS27643- d 'RG	DSP d SK1-R
MS27643- d 'RE	SDSP d S181-R
MS27643- d 'R	DSP d S181-R
MS27643- d 'GE	SDSP d SK1
MS27643- d 'G	DSP d SK1
MS27643- d 'E	SDSP d S181
MS27643- d '	DSP d S181

Where
d = Bore code
d' = d without space for $d \leq 8$
d for $d \geq 10$

Example

AS part number	SKF designation
MS27643- 6 RGE	SDSP 6 SK1-R



Spherical plain bearings

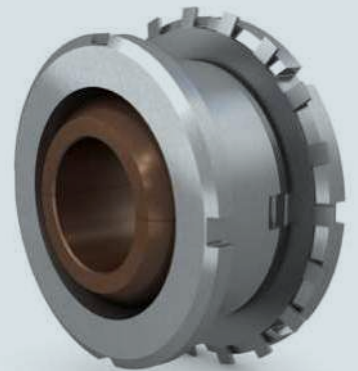
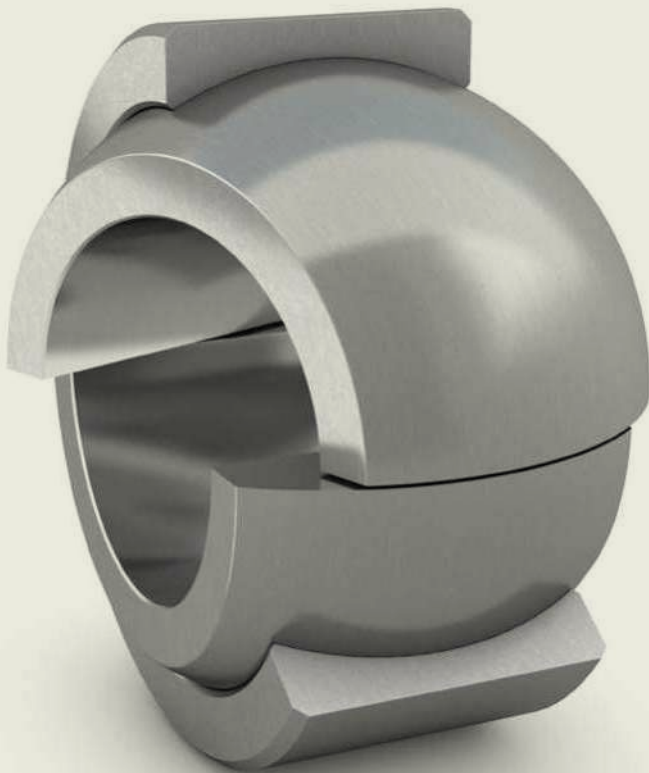

2 Spherical plain bearings

Bearing terminology	128	Dismounting	155
Bearing types	129	Storage	155
Metal-to-metal spherical plain bearings	129	Product tables Metal-to-metal spherical plain bearings	
Self-lubricating spherical plain bearings	130	Metric dimensions	156
Rod ends	130	2.1 Metal-to-metal loader slot, EN 2336, EN 2588	156
Common design features	130	2.2 Metal-to-metal loader slot normal, EN 2335	160
Customized bearings	131	2.3 Metal-to-metal loader slot normal reinforced	164
Basic selection guidelines	131	2.4 Metal-to-metal loader slot wide	166
Metal-to-metal spherical plain bearings	132	2.5 Metal-to-metal swaged light, EN 2335	168
Designs and variants	132	2.6 Metal-to-metal swaged narrow	172
Bearing designs	132	2.7 Metal-to-metal swaged wide	176
Bearing variants	132	2.8 Metal-to-metal swaged high misalignment	180
Bearing series	132	2.9 Metal-to-metal split	182
Bearing selection process	134	Inch dimensions	184
Selecting bearing size and options	134	2.10 Metal-to-metal loader slot wide	184
Load carrying capability	134	2.11 Metal-to-metal swaged narrow, AS 21154, AS 21155	186
Internal clearance	136	2.12 Metal-to-metal swaged narrow, EN 6046	190
Lubrication	137	2.13 Metal-to-metal swaged wide	194
Operating temperature	138	2.14 Metal-to-metal swaged wide, EN 4265, EN 4266	198
Bearing data	138	2.15 Metal-to-metal swaged high misalignment	202
Material	138	2.16 Metal-to-metal swaged, AS 81936/1, AS 81936/2	206
Surface treatments	139	2.17 Metal-to-metal split	210
Dimensions and tolerances	140	Product tables Self-lubricating spherical plain bearings	
Sealing and shielding	140	Metric dimensions	214
Customized products	141	2.18 Self-lubricating light, EN 3048, EN 4037	214
Self-lubricating spherical plain bearings	142	2.19 Self-lubricating narrow, EN 2584, EN 4038	216
Designs and variants	142	2.20 Self-lubricating wide, EN 2585, EN 4039	220
Bearing selection process	142	2.21 Self-lubricating high misalignment, EN 4040	224
Selecting bearing size and options	142	2.22 Self-lubricating high misalignment	226
Load carrying capability	144	2.23 Self-lubricating pre-staked	228
Friction and torque	146	Inch dimensions	230
Internal clearance	147	2.24 Self-lubricating narrow controlled clearance	230
Operating temperature	147	2.25 Self-lubricating narrow, NSA 8134, NSA 8136	232
Bearing data	148	2.26 Self-lubricating narrow, AS 14101, AS 14104	236
Material	148	2.27 Self-lubricating narrow lined bore, AS 81820/1, AS 81820/4	240
Surface treatments	149	2.28 Self-lubricating wide, NSA 8135, NSA 8137	244
Dimensions and tolerances	149	2.29 Self-lubricating wide, AS 14102, AS 14103	248
Sealing and shielding	149	2.30 Self-lubricating wide lined bore, AS 81820/2, AS 81820/3	252
Lined bore	150	2.31 Self-lubricating high misalignment	256
Customized products	150	2.32 Self-lubricating high misalignment	258
Legacy products	151	2.33 Self-lubricating high misalignment	260
Legacy standards	151	2.34 Self-lubricating pre-staked	264
Customer standards	151	Cross-reference	268
Bearing interfaces	152	Metal-to-metal spherical plain bearings	268
Fits and tolerances	152	Metric bearings	268
Mounting	153	Inch bearings	270
Bearing retention	154	Self-lubricating spherical plain bearings	272
Anvil staking Process	154	Metric bearings	272
Roller staking	155	Inch bearings	274
Threaded or bolted retention plate	155		

2 Spherical plain bearings

2

SKF spherical plain bearings provide a lubricated and wear-resistant joint, designed to support loads in radial and axial directions while enabling low friction multi-directional oscillation. When needed, they can also accommodate axial movements along the shaft. See **figures 2 and 3**.

The inner ring of these bearings have a spherical convex outside diameter, while the outer rings have a correspondingly concave inside diameter, see **figure 1**.

The standard range of SKF spherical plain bearings is tailored to meet a variety of operating conditions:

- Load – from low to high, for static or dynamic conditions
- Motion – from quasi-static to highly dynamic, including low to high frequency oscillation
- Environment – for a range of ambient temperatures and environmental conditions

SKF spherical plain bearings provide:

- Long service life
- Minimal maintenance requirements
- High operational reliability

Spherical plain bearings are used widely in fixed wing and helicopter aircraft structures.

They can be found in many applications, including:

- Aerostructure
- Flight controls
- Rotors
- Actuators, attachment points and hinges
- Engine attachments
- Landing gears
- Doors

SKF Application Engineers can provide additional help to select the most suitable standard bearing solution or design a customized bearing to meet your application requirements.

Figure 1

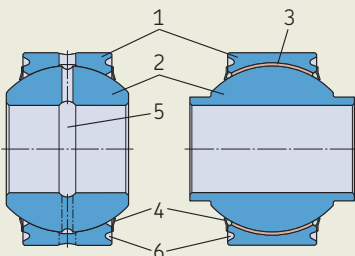

Bearing terminology

(Figure 1)

- 1 Outer ring
- 2 Inner ring
- 3 Liner
- 4 Seal/shield
- 5 Lubrication groove
- 6 Staking groove

Figure 2

Bearing motion

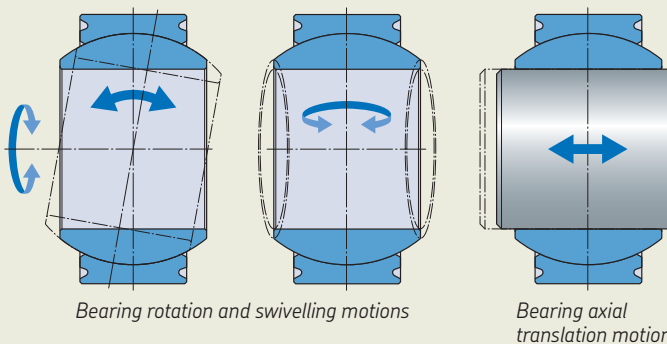
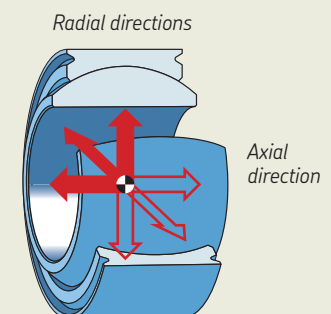

Figure 3

Bearing radial and axial directions



Bearing types

SKF supplies two types of spherical plain bearings (**figure 4**). The difference is in the sliding contact surface combination:

- Metal-to-metal
- Self-lubricating

Basic selection criteria

Metal-to-metal bearings are composed of two metallic rings that can slide directly on each other. These bearings require grease lubrication.

In self-lubricating bearings, the grease is replaced by a liner containing PTFE (polytetrafluoroethylene). The liner is bonded to the spherical contact surface in the outer ring.

To quickly determine what is suitable for your application, use **table 2, page 131**.

Metal-to-metal spherical plain bearings

Metal-to-metal spherical plain bearings use combinations of materials to accommodate different application conditions (such as static load, dynamic load, high temperature, liquid contamination) and corrosion resistance requirements, see **table 2, page 131**. Standard metal-to-metal spherical plain bearings use either steel for both the inner and outer rings or steel for one of the rings and bronze for the other (**table 1**).

Metal-to-metal bearings are supplied greased, ready for operation. Depending on application conditions, they may require periodic relubrication. Bearing variants with lubrication holes and grooves in the inner and/or outer rings are therefore available.

Refer to *Lubrication* **page 137**.

Good lubrication is necessary for optimal bearing performance.

Metal-to-metal bearings are designed to operate with clearance in the spherical contact. For additional information, refer to *Internal clearance* **page 136**.

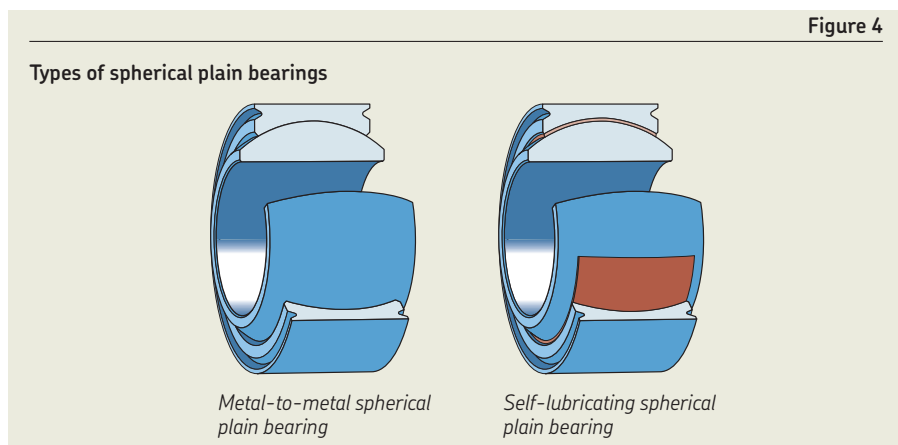

Table 1

Standard material combinations for metal-to-metal spherical plain bearings

Inner ring	Outer ring
Steel	Steel
Bronze	Steel
Steel	Bronze

Self-lubricating spherical plain bearings

Self-lubricating spherical plain bearings are “maintenance-free” and can accommodate relatively high loads.

“Maintenance-free” is an industry-wide term used to describe bearings with self-lubricating sliding contact surface combinations. The term “maintenance-free” does not imply that these bearings should not be inspected as part of a regularly scheduled maintenance programme, but that they offer a number of advantages including no need for relubrication.

As standard, inner and outer rings are manufactured from corrosion-resistant steel.

A liner containing PTFE is bonded to the spherical contact surface in the outer ring. It provides a low wear rate, relatively low friction, and a long bearing life especially under dynamic conditions. The bearing life under dynamic conditions can be further increased with SKF coating technologies applied on the spherical surfaces. Refer to *Surface coating* **page 148** and *Surface treatments* **page 149**.

For applications requiring axial movements along the shaft or when a secondary rotational motion in the bore is needed, self-lubricating bearings can be supplied with a liner in the bore of the inner ring. Refer to *Lined bore* **page 150**.

Self-lubricating bearings can be specified by their unloaded starting torque or supplied with controlled clearance in the spherical contact between the inner and outer rings. Refer to *Internal clearance* **page 147** and *Friction and torque* **page 146**.

Figure 5

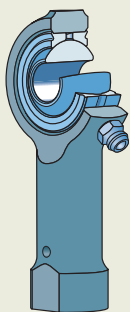

Rod end

Rod ends

Spherical plain bearings can be supplied as part of rod ends (**figure 5**). Rod ends are used for easy attachment of a bearing to the airframe structure. For information about these products, refer to *Rod Ends* **page 280**.

Common design features

The standard assortment of SKF spherical plain bearings is comprised of a wide range of designs, dimension series and sizes. It also includes a large variety of optional features (lubrication, sealing, surface treatments, etc.) to meet specific application needs. The most important options are related to outer ring design, surface treatments and coatings, seals and shields.

Outer ring design

The outer ring design supports the desired mounting method, see **figure 6**:

- Chamfered outer ring
Bearings with this feature are typically used when easy replacement is required. A suitable axial retention solution should be selected, refer to *Threaded or bolted retention plate* **page 155**.
- Staking groove
This enables positive retention. Staking grooves are machined in the outer ring and can be deformed into the housing's chamfers as a non-dismountable locking feature. Bearings can also be supplied with a pre-staked lip on the outer ring.

Figure 6

Outer ring designs

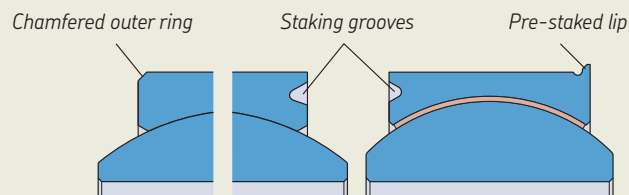

Surface treatments or coatings

Surface treatments or coatings, including dry lubricants, can be used to adapt bearings to application requirements. The most common benefits of using surface treatments or coatings are:

- Prolonged bearing life
- Enhanced corrosion resistance
- Enhanced fretting resistance

Seals or shields

SKF spherical plain bearings can be provided with shields or seals. Shields and seals are used to keep contaminants away from the sliding contact surfaces and, in the case of metal-to-metal bearings, to retain the grease in the sliding contact. Both effects can contribute to enhanced bearing performance.

Customized bearings

SKF supplies customized bearings to meet specific airframe application requirements. These solutions are the result of SKF's extensive experience and close cooperation between SKF and the customer's application experts.

SKF provides total solutions over the full bearing life cycle, including design, testing and partnership.

For additional information, refer to *Customized products* **page 141** for metal-to-metal spherical plain bearings and **page 150** for self-lubricating spherical plain bearings

Contact your regional SKF partner via www.skf.com/go/aero.

Basic selection guidelines

Guidelines to select the most suitable bearing type are listed in **table 2**.

More detailed information about selecting spherical plain bearings is provided in *Metal-to-metal bearings* (**page 132**) and *Self-lubricating bearings* (**page 142**).

Table 2

Basic selection guidelines

Characteristic	Metal-to-metal (Inner ring/outer ring material)		Self-lubricating	
	Steel/steel	Bronze/steel	Steel/bronze	
Performance under static loading conditions	+++	++	+	++
Performance under dynamic loading condition	++	+++	+++	+++
Wear resistance	+++	++	++	+
Seizing resistance	+	++	++	+++
Corrosion resistance	++	+++	++	++
Performance in presence of contaminants with appropriate re-greasing	++	+++	+++	N/A
Performance in presence of contaminants in "maintenance-free" condition	+	+	+	++
High frequency oscillation and/or vibration	+	+	+	+++

Symbols: N/A = Not applicable + = Moderate performance ++ = Good performance +++ = Very good performance

Metal-to-metal spherical plain bearings

Designs and variants

2

Bearing designs

SKF can offer different designs of metal-to-metal spherical plain bearings, see **table 3**.

Key differences and selection criteria between the different metal-to-metal spherical plain bearing designs are listed in **table 4**.

Bearing variants

According to the bearing design, different variants are available. Variants can be characterized by:

- Geometry: “light” (thin section), “narrow”, or “wide”
- Function: “high load” or “high misalignment”

These variants can be combined with other variations and optional design features, like standard or reduced internal clearance, lubrication, surface treatments, as well as staking grooves or chamfers on the outer ring.

This allows spherical plain bearings to accommodate a wide range of application requirements (compactness, load carrying capability, swivelling angle) without requesting a customized bearing.

Bearing series

Readily available bearing series are listed in **table 5** for metric dimensions and **table 6** for inch dimensions.

Table 3



Bearing designs	Figure	Description
Loader slot		<ul style="list-style-type: none"> • The first generation of metal-to-metal spherical plain bearings. • The outer ring has two slots in one side face. The slots are dimensioned larger than the inner ring. • The slots enable the inner ring to be easily mounted in the outer ring and to be easily dismounted. • The inner ring can also be mounted into a housing, such as a rod end body machined with slots. Refer to <i>Rod end</i> page 280. • Load carrying capability is reduced when load is applied in the direction of the slots.
Swaged		<ul style="list-style-type: none"> • Swaging gives a spherical form to the outer ring by using the inner ring as the template. The outside diameter and the side faces of the outer ring are then re-machined. • This design provides more sizes and variants (including high-misalignment) compared to loader slot bearings. • The baseline for most of the international standards. • Limited material combinations are possible due to the swaging process. The outer ring material's ductility must allow for the swaging deformation while the inner ring hardness must sustain the swaging pressure. Refer to <i>Material</i> page 138.
Split inner ring		<ul style="list-style-type: none"> • Both inner and outer rings are machined. The inner ring is split in two parts. When mounted in the outer ring, there is a small gap between the two inner ring halves. • Enables the inner ring to be easily mounted in the outer ring and to be easily dismounted. • It is also possible to mount the split inner ring in a machined housing, such as a rod end body, a fitting or a shackle. Refer to <i>Customized products</i> page 141.

Table 4



Design/properties	Loader slot	Swaged	Split inner ring
			
Load carrying capability	High but reduced in the direction of the slots	High	Very high
Material combination options	All	Limited by swaging process	All
Other capabilities	Easy mounting/dismounting of the inner ring	High misalignment variant	Easy mounting/dismounting of the inner ring

Table 5

SKF metal-to-metal spherical plain bearings, metric dimensions









Design		Variant	Standard	SKF series	Table number	Page
Loader slot		EN	EN 2336, EN 2588	GE	2.1	156
		SKF	–	GL	2.2	160
		High load	–	GLS...RTG	2.3	164
		Wide	–	GT	2.4	166
Swaged		Light	EN 2335	MA	2.5	168
		Narrow	–	ME	2.6	172
		Wide	–	ML	2.7	176
		High misalignment	–	MT	2.8	180
Split inner ring		SKF	–	2 PL	2.9	182

Table 6

SKF metal-to-metal spherical plain bearings, inch dimensions

Design		Variant	Standard	SKF series	Table number	Page
Loader slot		Wide	–	GT	2.10	184
Swaged		Narrow	AS 21154, AS 21155	ME	2.11	186
		Narrow	EN 6046	ENE	2.12	190
		Wide	–	ML	2.13	194
		Wide	EN 4265, EN 4266	ENL	2.14	198
		High misalignment	–	MT	2.15	202
		AS	AS 81936/1, AS 81936/2	QXMB	2.16	206
Split inner ring		SKF	–	2 PL	2.17	210

Bearing selection process

Selecting bearing size and options

2

If you are looking for a known bearing, according to its standard for example, or if you are an experienced bearing expert, use **tables 5 and 6, page 133** to find the relevant bearing table.

For help in selecting the appropriate bearing size and options, follow these steps:

- 1 Determine the range of allowable interface dimensions for the bearing. Often the boundary dimensions are predetermined by the space available on the aircraft system. Typically, the shaft diameter determines the bearing's bore diameter.
- 2 Determine the static radial and axial loads requirements. For more information refer to *Load carrying capability page 134*.
- 3 Determine the required swivelling angle.
- 4 From the product tables find a bearing design and series with sufficient static load carrying capability and swivelling angle capability that best fits the required dimensions.

Example

An inch bearing for high misalignment is needed. **Table 6** suggests MT series on **page 202**. For a maximum outside diameter of 25,4 mm and a static radial load capacity of 55 kN, MT9.52 can be selected.

- 5 Depending on the operating and loading conditions (static or dynamic) select the appropriate material combination. As specified in **table 2** for metal-to-metal spherical plain bearings:
 - Bronze/steel or steel/bronze bearings are typically used for dynamic applications with rotational or swivelling movement. For motion in bore, select a bronze inner ring.
 - Steel/steel bearings are typically used for static or dynamic application with low rotational or swivelling motion during life.

For more information, refer to *Load carrying capability page 134*.

- 6 Choose all other required options, including *Lubrication (page 137)*, *Surface treatments (page 139)*, *Internal clearance (page 136)*, *Sealing and shielding (page 140)*, *Dismounting and Oversized dimensions (page 155)*, *Staking grooves and mounting condition (pages 130 and 154)*.

If the standard SKF range of metal-to-metal spherical plain bearings does not meet your specific needs, contact SKF for a customized design solution, as described in *Customized products page 141*

Load carrying capability

Radial and axial static limit load

The static limit load of a bearing is the maximum permissible static operational load that the bearing can withstand without permanent deformation and without loss of bearing functionality or performance.

The static limit loads listed in the product tables are valid for the steel/steel spherical plain bearings without lubrication groove. For other bearings, consider the following reductions:

- Bronze outer ring
 - Static limit loads are 60% of the equivalent steel/steel bearing
- Bronze inner ring
 - Static limit loads are 90% of the equivalent steel/steel bearing
- Lubrication grooves
 - The static limit loads are slightly reduced. Contact SKF for further information

In case of combined loads (both axial and radial), each component should be analyzed separately, see **figure 7**.

NOTE: For loader slot bearings, the static limit loads listed in the relevant product tables are only valid when the load is not applied in the direction of the slots, see **figure 8**.

Figure 7

Bearing radial and axial loads

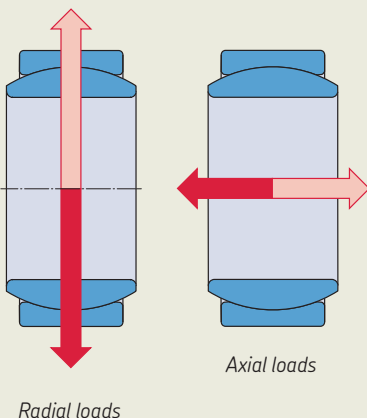
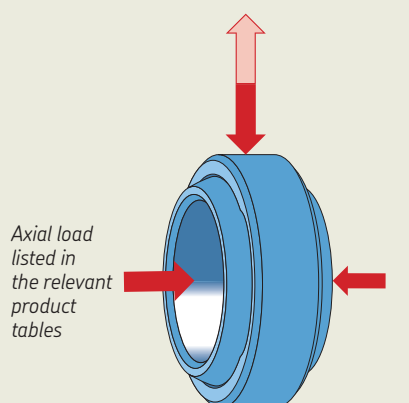

Figure 8

Loader slot bearing radial and axial loads



Ultimate static loads

The ultimate load is the highest load the bearing can support without any fracture, failure or inner ring push-out. It is defined as 1,5 times the corresponding radial or axial static limit load.

Spherical plain bearings exposed to this load level are no longer guaranteed to be fully functional and should be replaced.

Dynamic load rating

Metal-to-metal spherical plain bearings can support fatigue and endurance dynamic loading.

- Fatigue dynamic loading is when the load is alternating with no imposed swivelling or rotational movement
- Endurance dynamic loading is when the load is applied constantly or alternating with swivelling and/or rotational movement, see **figure 9**.

SKF's metal-to-metal spherical plain bearing can accommodate different dynamic loading conditions depending on the sliding contact surface combinations, as described in **table 7**.

Bearing end-of-life criteria can be:

- Seizing of the bearing
- The maximum allowable internal clearance limit for the application is reached due to wear

The bearing should be replaced when one of the above limits is reached.

For a unidirectionally loaded application, the wear on one bearing surface equates to bearing internal clearance. For a reversing load application, wear occurs on two surfaces and the sum equates to the bearing internal clearance. See **figure 10**.

Wear rate and risk of seizing depend on the lubrication and relubrication conditions, refer to **Lubrication page 137**. They can be increased due to operation in harsh environmental conditions such as exposure to solid contamination with sand and dust.

In these cases, consider using sealing or shielding solutions (**Sealing and shielding page 140**).

SKF can also provide surface treatments to extend bearing dynamic life by improving contact conditions and thus delaying wear and seizing (**Surface treatments page 139**).

Figure 9

Bearing motion in endurance

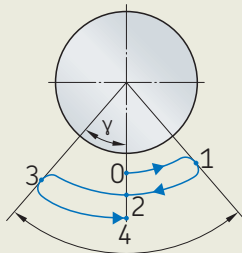
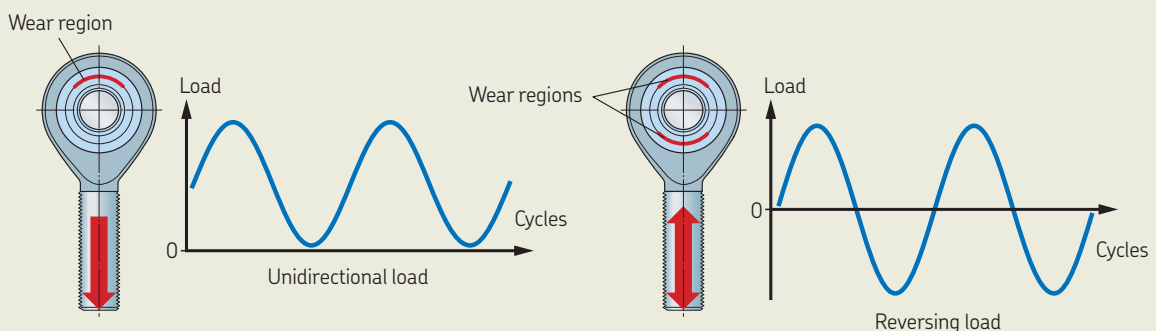

Table 7

Sliding contact surface combinations (Inner ring/outer ring)	Typical dynamic loading condition
Steel/steel	<ul style="list-style-type: none"> • Fatigue
Steel/bronze	<ul style="list-style-type: none"> • Fatigue • Endurance at low frequency
Bronze/steel	<ul style="list-style-type: none"> • Fatigue • Endurance at low frequency • Bore motion

Figure 10

Bearing loading condition and wear regions



Internal clearance

Bearing internal clearance is defined as the total distance through which one bearing ring can be moved relative to the other (**figure 11**) under a defined measuring load (**table 8**) according to the relevant standard. It can be measured in the radial direction (radial internal clearance) or in the axial direction (axial internal clearance).

NOTE: For loader slot bearings, radial internal clearance is not measured in the direction of the slots.

Internal clearance is needed for metal-to-metal spherical plain bearings to function properly and to enable a uniform lubrication film to be formed in the spherical contact.

Standard metal-to-metal spherical plain bearings can be supplied with standard or reduced internal clearance.

Reduced internal clearance is suitable when the following application requirements need to be fulfilled :

- Low noise and vibration level
- High stiffness of the system
- A low end-of-life clearance when operating under dynamic conditions

Radial and axial clearance values are listed in the relevant product tables.

The initial internal clearance can be impacted by:

- Mounting conditions. Refer to *Mounting* **page 153**
- Thermal expansion of the bearing rings and associated components

These effects must be considered when selecting the initial internal clearance.

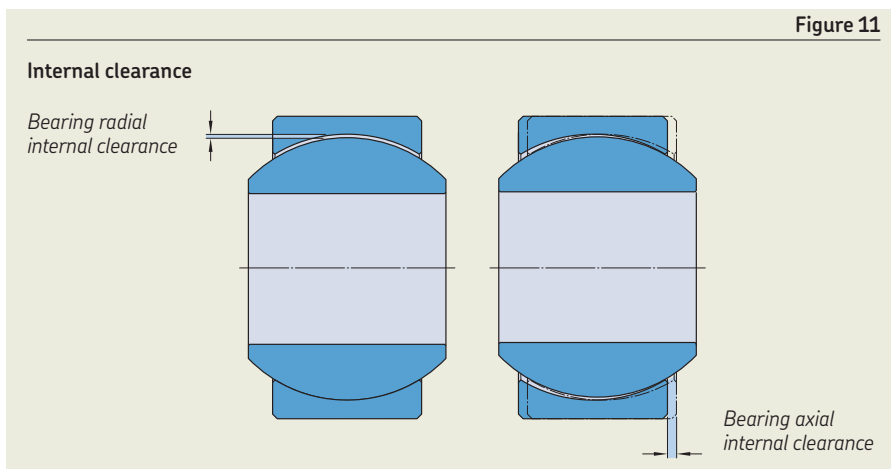

Table 8

Measuring loads for internal clearance measurements

Bearing series	d ≤ 20 mm	d > 20 mm
To AS standard	25 N	25 N
To EN standard	50 N	100 N
Other series	50 N	100 N

Table 9

Standard greases

NATO codes	Standard	Operating temperature
G395	MIL PRF 81322	-54 to +177 °C (-64 to +350 °F)
G354	MIL PRF 23827 type I	-73 to +121 °C (-100 to +250 °F)
G353	MIL G 21164	-73 to +121 °C (-100 to +250 °F)

Lubrication

Metal-to-metal spherical plain bearings are supplied greased, ready to be put into operation.

They can be:

- Greased-for-life
This is especially suitable for static and fatigue loading conditions.
- Relubricated periodically
This is especially suitable for endurance conditions. To facilitate this operation, lubrication holes and grooves can be provided, refer to *Lubrication grooves* **page 137**. For optimum bearing performance, relubrication should be performed frequently, for instance, during aircraft planned maintenance.

Refer to *Load carrying capability* **page 134** for more information about static, fatigue and endurance bearing performance with respect to lubrication.

Lubrication helps to:

- Reduce friction
- Reduce wear rate
- Reduce seizing risk
- Extend bearing service life
- Protect against corrosion
- Expel contaminants and wear debris

Lubricants

The greases used for standard metal-to-metal spherical plain bearings are listed in the relevant product tables. **Table 9** gives the different designations, reference standards and operating temperatures for these greases.

Lubrication is primarily chosen according to the operating temperature, refer to **table 9**, **page 136** for more information.

WARNING: To prevent risk of bearing failure, use the same lubricant as supplied when relubricating.

Lubrication grooves

To facilitate lubricant supply to the sliding surfaces, metal-to-metal spherical plain bearings requiring periodic relubrication are available with relubrication grooves and holes in either the inner ring, the outer ring, or both rings (**figure 12**). Available options are listed in the relevant product tables.

Selection should be made according to the grease input locations in the housing or shaft:

- For grease inputs in the housing, select code C or Y
- For grease inputs in the shaft, select code S or Y
- For grease inputs in both the shaft and housing, select code Y

Refer to **figures 13** and **14** for examples.

Figure 12

Lubrication grooves

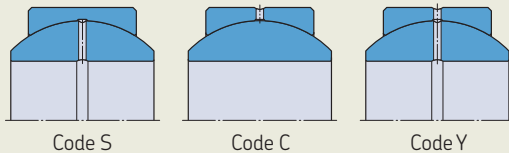

Figure 13

Relubrication via the outer ring

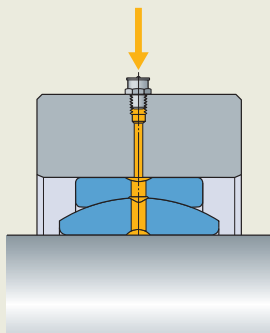
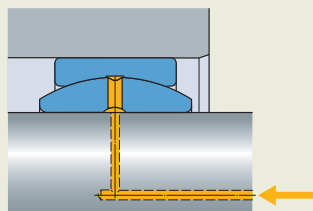

Figure 14

Relubrication via the inner ring



Operating temperature

The permissible operating temperature of standard metal-to-metal spherical plain bearings is limited by the grease capability (**table 9, page 136**).

For operation outside this temperature range, standard bearing life and performance may be reduced. Contact SKF for more information.

A wider operating temperature range can be achieved by using dry lubricants (refer to *Dry lubricants* **page 139**) or *Customized products* (refer to *Customized products* **page 141**).

Bearing data

Material

SKF metal-to-metal spherical plain bearings are primarily available in the following materials:

- Bearing steel, for high strength
- Corrosion-resistant steel, for high strength and good corrosion resistance
- Copper alloys (bronze materials), for good corrosion resistance and enhanced dynamic performance (refer to *Dynamic load rating* **page 135**)

Depending on bearing design, inner and outer rings can be selected in different material combinations, as follows.

SKF can offer many other material combinations. Contact SKF at www.skf.com/

go/aero and refer to *Customized products* **page 141**.

Loader slot spherical plain bearings

Standard loader slot spherical plain bearings can be made of :

- Bearing steel (No code)
- Corrosion-resistant steel (Code W)
- Bronze beryllium for the inner ring and bearing steel for the outer ring (Code Q)

Table 10 gives the different designations, reference standards and key characteristics for these materials.

Swaged spherical plain bearings and bearings with a split inner ring

The sliding contact surfaces of standard swaged spherical plain bearings and bearings with a split inner ring are manufactured in different material combinations as shown in **figure 15**.

Selection is to be made according to operating conditions, refer to *Bearing selection process* **page 134**.

- Inner ring: corrosion-resistant steel 440C (codes W and WQ) or bronze beryllium (code Q)
- Outer ring: corrosion-resistant steel 17-4PH (codes W and Q) or bronze aluminium (Code WQ)

Table 11 gives the different designations, reference standards and key characteristics for these materials.

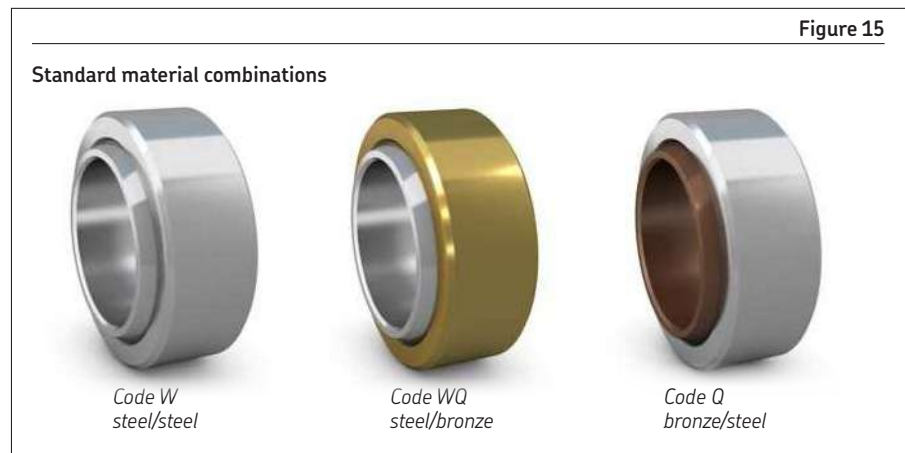

Table 10

Standard materials for loader slot bearings

Steel type	Corrosion resistance	Hardness HRC	Material designation	EN standards	AMS standards	Equivalent designation
Bearing steel	Moderate	For IR ¹⁾ = 60 to 63 For OR ²⁾ = 58 to 62	52100	EN 2031	AMS 6440 or AMS 6444	100Cr6 (100C6)
Corrosion-resistant steel	Good	For IR ¹⁾ = 55 to 62 For OR ²⁾ = 58 to 61	440C	EN 2030	AMS 5630 or AMS 5618	X105CrMo17 (Z100CD17)
Bronze beryllium	Very good	≥ 37	CuBe 1.9	–	AMS 4533 or AMS 4535	–

1) IR means inner ring

2) OR means outer ring.

Surface treatments

Spherical plain bearings can be exposed to various environmental conditions including humidity, heat and contamination. These can increase the risk of corrosion, wear and seizing.

Therefore, SKF supplies spherical plain bearings with standard surface treatments including:

- Zinc-nickel or cadmium¹⁾ plating on the outer ring external surfaces, typically used to enhance corrosion resistance and/or fretting resistance
- Chromium plating¹⁾ or SKF's chromium replacement coating (XCR) in the spherical contact, typically used to enhance corrosion resistance and/or dynamic performance. SKF's XCR surface treatment is free from chromium 6 compounds and has equivalent performance in comparison to chromium plating

- Corrosion-resistant steel inner rings can be passivated as required per the relevant standards

Surface treatments for SKF metal-to-metal spherical plain bearings are applied according to the following standards:

- Passivation according to AMS 2700 or ISO 8075
- Cadmium plating¹⁾ according to AMS-QQ-P-416 or AMS03-19²⁾
- Zinc-nickel plating according to AMS 2417
- Hard chromium plating¹⁾ according to AMS 2460³⁾

The bearing interface dimensions and tolerances from product tables are not modified when surface treatments are used.

For specific surface treatments, refer to the *Customized products* **page 141**.

Dry lubricants

Dry lubricants such as MoS₂ or graphite lubricants can be used:

- When required by the relevant standards
- For improved fatigue performance including fretting resistance
- To extend the operating temperature range of SKF metal-to-metal spherical plain bearings. Dry lubricants can be used at temperatures above the range of standard greases. Depending on the dry lubricant, temperatures up to 260 °C (500 °F) can be accommodated. The bearing design and materials must be suitable for the temperature range of the application. For detailed information contact SKF and refer to *Customized products* **page 141**.

¹⁾ Treatment includes chromium 6 compounds and may be subject to environmental legislation

²⁾ Formerly DEF STAN 03-19

³⁾ Formerly AMS QQ-C-320

Table 11

Standard materials for swaged bearings and bearings with a split inner ring

Material type	Bearing type	Corrosion resistance	Hardness HRC	Material designation	EN standards	AMS standards	Equivalent designation
Corrosion-resistant steel	Swaged and split	Good	For EN series = 55 to 62 For AS series ≥ 56 For other series ≥ 58	440C	EN 2030	AMS 5630 or AMS 5618	X105CrMo17 (Z100CD17)
	Swaged	Very good	For AS 21154 and AS 21155 series = 27 to 36 For inch EN series = 28 to 38 For other series = 28 to 37	17-4PH H1150	EN 2539 or EN 3161	AMS 5643	Z6CNU17.04 H1150
	With split inner ring	Very good	34 to 42	17-4PH H1025	EN 2539 or EN 3161	AMS 5643	Z6CNU17.04 H1025
Bronze Beryllium	Swaged and split	Very good	≥ 37	CuBe 1.9	–	AMS 4533 or AMS 4535	–
Bronze aluminium	Swaged and split	Very good	No standard requirement	CuAl10Ni5Fe4	–	AMS 4640	–

Dimensions and tolerances

Relevant interface dimensions and tolerances are listed in the product tables.
Where:

Δd_{mp} = Single plane mean bore diameter deviation

ΔD_{mp} = Single plane mean outside diameter deviation

Figure 16, top figure, shows measurement definitions for a single plane mean diameter deviation.

And

Δd_s = Deviation of a single bore diameter

ΔD_s = Deviation of a single outside diameter

Figure 16, bottom figure, shows measurement definitions for the deviation of a single diameter.

For more information about the measurement principle of interface dimensions and tolerances, refer to ISO 1132.

Sealing and shielding

Most spherical plain bearings can be supplied with seals (codes TT, E or EE) or shields (code PP). Refer to the relevant product tables, see **figure 17**.

Seals and shields protect the spherical contact area against solid contaminants such as dust or sand. Seals should be considered in environments with high contamination. They can also protect against liquid contaminants such as hydraulic fluids or de-icing liquids.

The shields are fixed on the outer ring and are in close contact with the inner ring spherical surface. For sealed versions, seals are pressed between shields and the inner ring spherical surface.

For customized sealing and shielding solutions, refer to *Customized products* **page 141**.

The geometrical, physical and mechanical characteristics of the sealed and shielded spherical plain bearings are identical to those of non protected bearings, except:

- The life under dynamic load in contaminated environments can be increased significantly
- The torque, especially for sealed bearings, can be increased
- The swivelling angle is reduced by 2 to 4° depending on the bearing type

Figure 16

Dimensional tolerances measurement principle

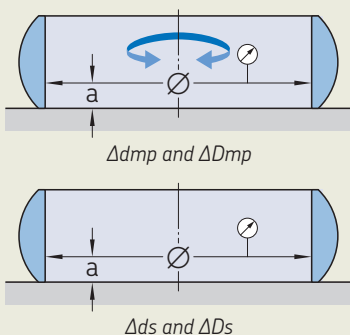
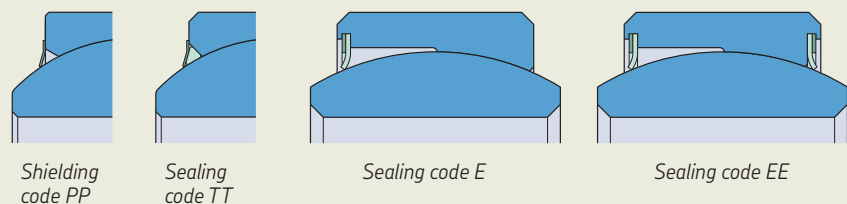

Figure 17

Standard sealing and shielding solutions



Customized products

SKF designs and manufactures customized metal-to-metal spherical plain bearings to meet customer-specific application requirements.

Examples can include, but are not limited to:

- **Specific dimensions, clearances and geometries**

- **Materials**

- Alternative steel and corrosion-resistant steel alloys such as 15-5PH per AMS 5659 or other, or PH13.8 per AMS 5629 or other.
- Alternative bronze alloys, especially for highly demanding dynamic operating conditions
- High temperature materials such as nickel or cobalt alloys
- Coated titanium alloys for lightweight solutions

- **Surface treatments**

- Including:
- Silver plating
 - PVD

Certain treatments include chromium 6 compounds and may be subject to environmental legislation

- **Alternative lubricants and dry lubricants**

Function Typical SKF customized solutions

Mounting and axial stops



Screwed flange



Nut and washer



Pre-staked



Fitting design

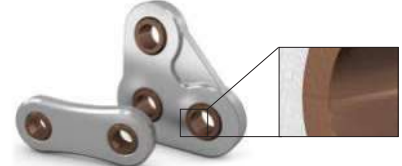

Shackle design. For multi bearing interfaces

Geometries and designs



Split outer ring



Inner rings supplied on their own

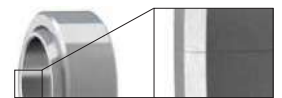

Split inner ring, no gap

Rotation and swivelling stops



Bump stops

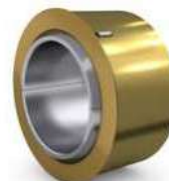

Pin

Sealing and lubrication



Specific lubrication groove designs and sealing features to optimize bearing protection, lubrication and relubrication, even under load:

- Extend bearing life
- Extend relubrication intervals
- Allow for larger motions
- Use of grease nipple solutions to allow relubrication without holes or grooves in housing and shaft

Improved motion in bore



Sleeve



Liner in bore

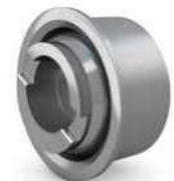

Counterbore, pockets, notches

2

Self-lubricating spherical plain bearings

2

SKF self-lubricating spherical plain bearings use a PTFE-based liner bonded to the outer ring spherical surface. The liner system provides lubrication for the lifetime of the bearing. No additional lubrication is used. This is why these bearings are often referred to as "maintenance-free".

WARNING: Self-lubricating spherical plain bearing must not be lubricated. This may result in damage to the liner and reduced bearing performance.

For self-lubricating spherical plain bearings operating under load and oscillation condition, some PTFE material is transferred from the liner to the inner ring surface creating a third body, enabling low wear and low friction sliding. The PTFE transfer results in a reduction in the thickness of the liner by wear and an increase in the bearing internal clearance. Refer to *Bearing life* **page 145**.

Designs and variants

The standard assortment of SKF self-lubricating spherical plain bearings comprises:

- Chamfered or grooved outer ring, depending on mounting conditions. Refer to *Mounting chapter* **page 153**. Grooved outer rings can have a pre-staked lip or not
- Variations in boundary dimensions: "light" (thin section), "narrow" and "wide" variants
- Variants with different functions: "high misalignment" and "controlled clearance" variants

Standard self-lubricating bearings are swaged. Swaging gives a spherical form to the outer ring by using the inner ring as the template. The outside diameter and the side faces of the outer ring are then re-machined. Material combination options are limited due to the swaging process. The outer ring material's ductility must allow for the swaging deformation while the inner ring hardness must sustain the swaging pressure. For more information, refer to *Material* **page 148**.

Bearing selection process

Selecting bearing size and options

If you are looking for a known bearing, according to its standard for example, or if you are an experienced bearing expert, use **tables 12** and **13** to find the relevant bearing.

For help in selecting the appropriate bearing size and options, follow these steps:



- 1 Determine the range of allowable interface dimensions for the bearing. Often the boundary dimensions are predetermined by the space available on the aircraft system. Typically, the shaft diameter determines the bearing bore diameter.
- 2 Determine the static radial and axial load requirements. For more information refer to *Load carrying capability* **page 144**.
- 3 Determine the required swivelling angle.

- 4 From the product tables, find a bearing design and series with sufficient static load carrying capability and swivelling angle capability that best fits the required dimensions.
 - For example, for high misalignment bearings, select XRT series. For a maximum bearing size of 25,4 mm with a static radial load capacity of 55 kN, then XRT9,52 can be selected.
- 5 If the bearing operates under dynamic conditions, compare the application loading conditions to the bearing dynamic loads listed in the relevant product table to select the appropriate bearing series and size. Refer to *Dynamic load carrying capability and bearing life* **page 144**.
- 6 Choose all other required options, including Surface treatments (**page 149**), Friction and torque (**page 146**), Internal clearance (**page 147**), Sealing and shielding (**page 149**), Dismounting and Oversized dimensions (**page 155**), Staking groove and mounting condition (**pages 130** and **154**).

If the standard SKF range of self-lubricating spherical plain bearings does not meet your specific needs, contact SKF for a customized design solution, as described in *Customized products* **page 150**.

Table 12

Self-lubricating spherical plain bearings, metric dimensions

Figure	Variant	Standard	SKF series	Table number	Page
	Light	EN 3048, EN 4037	LEN..	2.18	214
	Narrow	EN 2584, EN 4038	NEN..	2.19	216
	Wide	EN 2585, EN 4039	WEN..	2.20	220
	High misalignment	EN 4040	HMEN..	2.21	224
	High misalignment	–	XRT..	2.22	226
	Pre-staked	–	XRL..FR	2.23	228

2

Table 13

Self-lubricating spherical plain bearings, inch dimensions

Figure	Variant	Standard	SKF series	Table number	Page
	Narrow controlled clearance	–	SN..ZT	2.24	230
	Narrow	NSA 8134, NSA 8136	SN..	2.25	232
	Narrow	AS 14101, AS 14104	NAS..	2.26	236
	Narrow lined bore	AS 81820/1, AS 81820/4	NAS..A..	2.27	240
	Wide	NSA 8135, NSA 8137	SW..	2.28	244
	Wide	AS 14102, AS 14103	WAS..	2.29	248
	Wide lined bore	AS 81820/2, AS 81820/3	WAS..A..	2.30	254
	High misalignment	–	SH..	2.31	256
	High misalignment	–	11..H..	2.32	258
	High misalignment	–	XRT..	2.33	260
	Pre-staked	–	XRL..FR	2.34	264

Load carrying capability

SKF bearings have been tested in accordance with AS 81820 (Technical specification for bearings, plain, self-aligning, self-lubricating, low speed oscillation) and EN 2755 (Aerospace series, bearings, spherical plain in corrosion-resisting steel with self-lubricating liner – elevated load at ambient temperature – technical specification). They meet the requirements of static load, deflection and permanent set, and all dynamic wear limits.

The ultimate stress levels of SKF lining materials in compression are greater than the yield stress of the corrosion-resistant steel normally used as inner and outer ring materials. Due to the strength of the inner ring material being higher than that of the outer ring material in standard swaged bearings, the static loads are determined by the strength of the outer ring material and liner contact area.

Static limit load

The static limit load of a bearing is the maximum permissible static operational load that the bearing can withstand without permanent deformation and loss of capability. The static limit loads as listed in the product tables are in conformance with the associated standard that they are designed to (AS or EN).

Static radial limit load

The approximate radial static limit load, C_s can be calculated using:

$$C_s = \frac{2}{3} \sigma_{\text{yield}} A_r$$

Where:

C_s Radial static limit load [N/lbf]
 σ_{yield} Outer ring yield stress [MPa/psi]
 A_r Radial projected area [mm²/in²]

(table 14)

Static axial limit load

The approximate axial static limit load, C_a can be calculated using:

$$C_a = \frac{1}{3} \sigma_{\text{yield}} A_a$$

Where:

C_a Axial static limit load [N/lbf]
 σ_{yield} Outer ring yield stress [MPa/psi]
 A_a Axial projected area [mm²/in²]

(table 14)

In case of combined loads (both axial and radial), each component should be analysed separately.

Ultimate static load

The ultimate static load is the highest load the bearing assembly can support without any fracture, failure or inner ring push-out. It is defined as 1,5 times the corresponding permissible radial or axial static limit load.

Spherical plain bearings loaded at this level are no longer guaranteed to be fully functional and should be replaced.

Dynamic load carrying capability and bearing life

Self-lubricating spherical plain bearings can support fatigue or endurance dynamic loading.

- Fatigue dynamic loading is when the load is alternating with no imposed swivelling or rotational movement
- Endurance dynamic loading is when the load is applied constantly or alternating, with swivelling and/or rotational movement

The dynamic load carrying capability listed in the relevant product tables corresponds to standard operational cases as defined in the aeronautical standards AS 81820 and EN 2755 with the following parameters:

- Unidirectional radial load
- Room temperature
- Rotation: $\pm 25^\circ$ (100° total per cycle). See **figure 18**, with $\gamma = 25^\circ$
- Duration: 25 000 cycles
- Speed: 10 cycles per minute

Table 14

Projected area

Direction

Radial

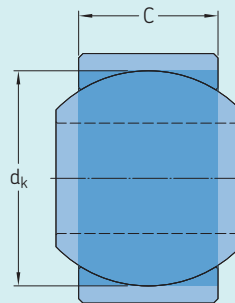

$$A_r = d_k(C - 1,6)$$

Where:

A_r Radial area [mm²]
 d_k Spherical diameter [mm]
 C Outer ring width [mm]

Axial

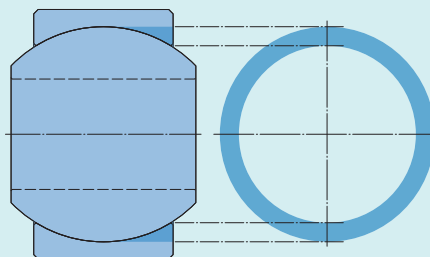

$$A_a = \pi \left(\left(\frac{d_k}{2} \right)^2 - \left(\left(\frac{d_k}{2} + t \right)^2 - \left(\frac{C}{2} - l_r \right)^2 \right) \right)$$

Where:

A_a Axial area [mm²]
 d_k Spherical diameter [mm]
 C Outer ring width [mm]
 t Liner thickness, typically 0,3 [mm]
 l_r Liner recess, typically 0,5 [mm]

The C25 dynamic load carrying capability is valid for bearings without inner ring surface coatings.

In most airframe applications, the operating dynamic load can be much lower than the bearing dynamic load carrying capability listed in the relevant product tables. This results in significantly lower operating bearing pressures than the standard C25 test case and therefore significantly increased expected bearing life.

Refer to *Bearing life* **page 145** and *Surface coating* **page 148** for more information about bearing end of life criteria and SKF coatings used for increased bearing life.

Bearing life

Typically, fatigue life is not the limiting factor for self-lubricating spherical plain bearings.

Self-lubricating spherical plain bearings operating under endurance loading conditions will have wear (**figure 19**) that increases the bearing internal clearance.

Bearing endurance life is determined by two criteria:

- The maximum allowable internal clearance limit
- The limit of usable liner thickness: a maximum wear depth per surface is used in life calculations

The bearing should be replaced when one of the above limits is reached.

For a unidirectionally loaded application, the wear on one liner surface equates to bearing internal clearance. For a reversing load application, wear occurs on two surfaces and the sum equates to the bearing internal clearance. See **figure 20**.

SKF can offer surface treatments applied to the inner ring spherical surface, adapted to enhance endurance life by improving contact conditions and thus reducing wear. For more information, refer to *Surface coating* **page 148**.

Influence of operational conditions

The bearing life of self-lubricating spherical plain bearings depends on many factors and can be reduced by:

- Increased operational load
- Increased angular oscillation and combination of rotation and swivelling
- Increased operational speed (frequency)
- Operating temperatures out of the range of -20 to +80 °C (-4 to +176 °F). Outside this range, the wear rate increases. For more information, refer to *Operating temperature* **page 147**.
- Environmental conditions including contamination such as exposure to liquid contaminants (fuel, hydraulic fluids or de-icing liquid)
- Excessive interference fitting conditions

Contact SKF for detailed calculations associated with specific operating conditions.

Figure 18

Oscillation angle γ

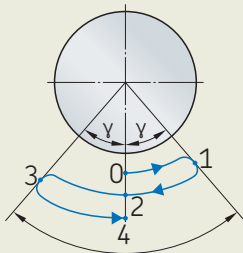
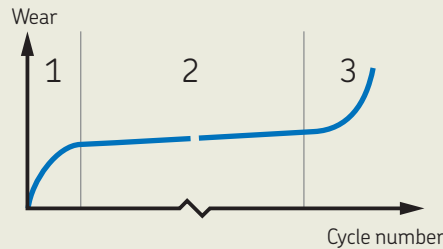

Figure 19

Bearing wear rate



- 1** Running-in phase
Decreasing wear rate
- 2** Normal operation
Low constant wear rate
- 3** Final wear phase
Accelerating wear rate

Figure 20

Bearing loading condition and wear regions

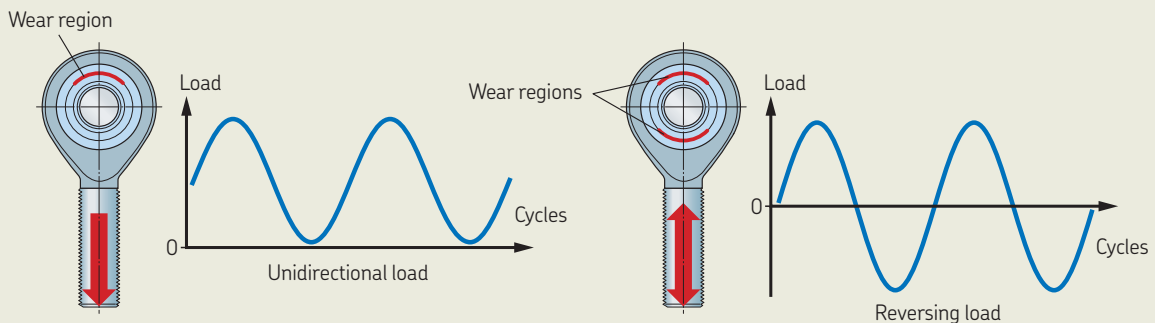

Friction and torque

Unloaded torque

Self-lubricating spherical plain bearings are designed and supplied with zero clearance and defined starting torques, except for the controlled clearance variant (in this case, refer to *Internal clearance* page 147).

For airframe self-lubricating spherical plain bearings, performing oscillation movements or a low number of complete rotations, the starting torque is a relevant design parameter. This is defined as the maximum torque required to start the rotation of one ring with the other one held stationary. This torque is measured without load applied on the bearing and after several rotational and swivelling motions have initially been made. For influence of load on torque, refer to *Loaded frictional moment* page 146.

SKF self-lubricating spherical plain bearings are produced with standard or reduced torques in accordance with the relevant product standards. The starting rotational torque or the rotational frictional moment for each bearing are defined in the relevant product tables.

The unloaded torque is not constant over time, with a starting torque higher than the bearing rotational frictional moment, also called dynamic rotational torque. This is due to the initial resistance to rotation that the bearing has to overcome before starting the rotation at the sliding contact interface (figure 21).

Sealing and shielding solutions increase the torque, as seals and shields make contact with the inner ring of the bearing. Refer to *Sealing and shielding* page 149.

The mounting conditions can influence the bearing unloaded torque. Refer to *Mounting* page 153.

Where specific installation requirements are necessary, it is possible to produce bearings with lower or higher starting torque than standard. Higher starting torques can be suitable for applications where greater operational stiffness is required.

Contact SKF for customized solutions and refer to *Customized products* page 150.

Loaded frictional moment

An estimate of the loaded rotational frictional moment at operational loads can be calculated using the following formula:

$$T = \mu F r$$

Where:

T = Loaded rotational frictional moment

[Nmm/lbin] 1 Nmm = 0,001 Nm

μ = Friction coefficient

F = Radial load [N/lb]

r = Half of the lined diameter, $d_x/2$ for spherical plain bearings [mm/in]

Approximate bearing friction coefficient as a function of operating conditions (temperature and pressure) can be estimated from diagram 1.

Frictional properties remain mostly constant over the operational wear thickness of the liner.

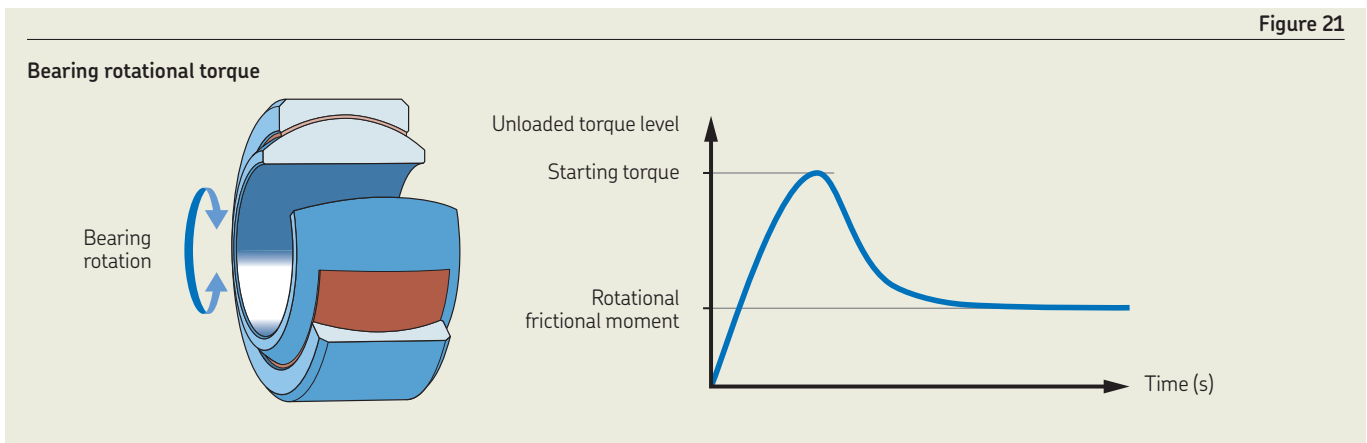
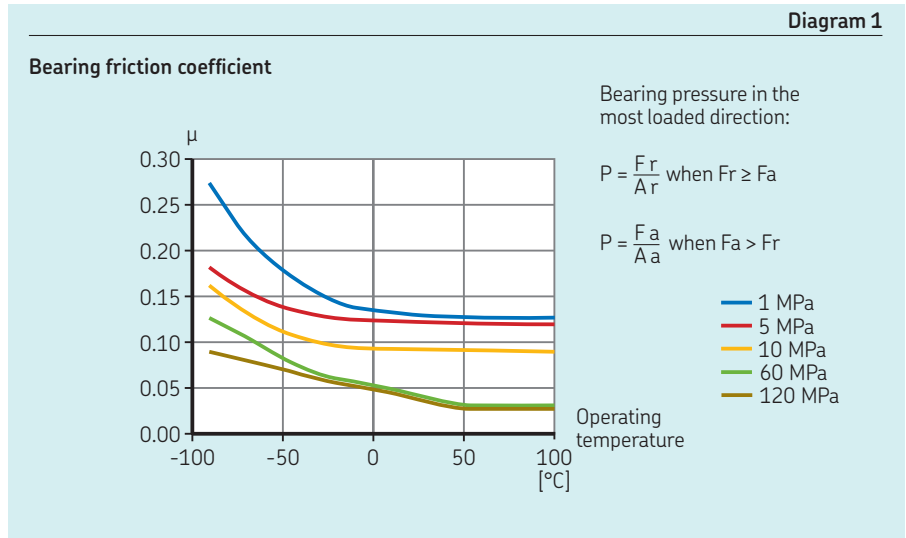

Internal clearance

SKF also supplies bearings with:

- Reduced torque resulting in a very small level of clearance within the bearing
- No torque and controlled clearance. This is typically used where specific installation requirements with high interference fit with the housing are necessary. This clearance will then be removed when under load or assembled into the application. Refer to *Controlled clearance bearing variants*. See **figure 22**.

Bearing clearance can be impacted by mounting conditions. Refer to *Mounting* page 153.

Operating temperature

Installation

For the purpose of installation by temperature difference, self-lubricating spherical plain bearings can be immersed in liquid nitrogen at $-193\text{ }^{\circ}\text{C}$ ($-315\text{ }^{\circ}\text{F}$). This is an established practice with no detrimental effect on the bearing.

Operation

Standard SKF self-lubricating spherical plain bearings are designed and tested to operate in the temperature range of -55 to $+163\text{ }^{\circ}\text{C}$ (-67 to $+325\text{ }^{\circ}\text{F}$), according to the requirements of AS 81820 and EN 2755.

The full operating temperature range of standard self-lubricating spherical plain bearings is -193 to $250\text{ }^{\circ}\text{C}$ (-315 to $+482\text{ }^{\circ}\text{F}$). Note that throughout the temperature range, due to the PTFE lubricant in the liner, temperature impacts the wear rate and therefore bearing life.

This impact must be assessed against the function of the bearing (contact SKF). Key parameters include:

- Oscillation type (rotation and/or swivelling).
- Large or small motion angle
- High or low speed
- Percentage time at temperature

Refer to *Bearing life* page 145. Contact SKF for operation outside these conditions or for customized bearings.

The relevant temperature ranges are shown in **figure 23** using the SKF traffic light concept.

Effect of thermal expansion

Due to the relatively thin layer of the liner, the coefficient of thermal expansion of the liner may be regarded as being identical to that of the bearing ring.

When selecting a bearing, the materials of the housing and shaft must also be considered as differing coefficients of thermal expansion can modify both assembled fit and bearing torque.

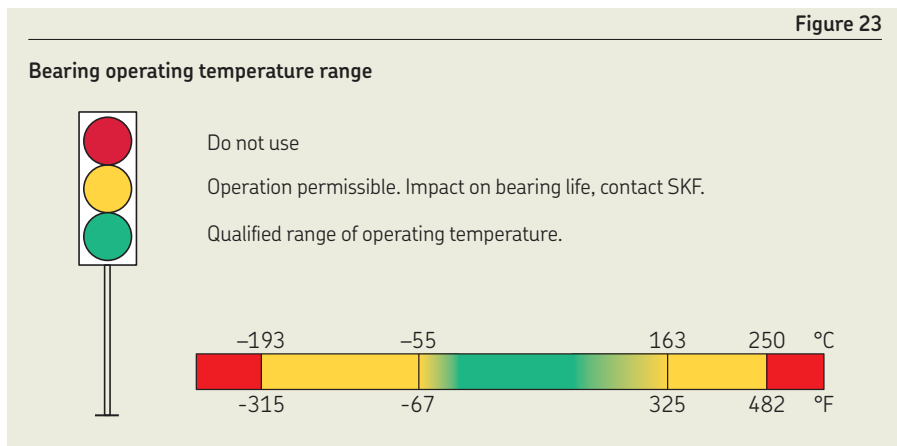
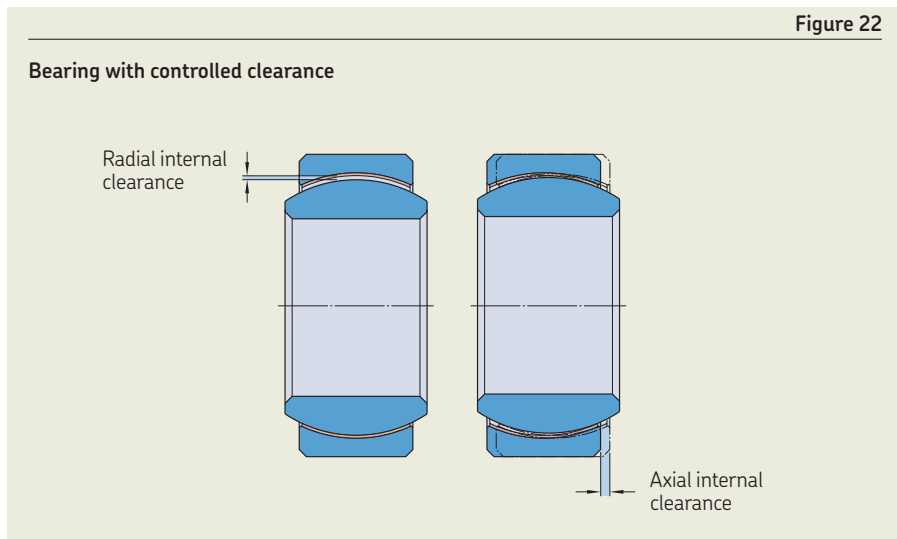

Bearing data

Material

SKF standard self-lubricating spherical plain bearings are primarily available in corrosion-resistant steel. Such materials have good mechanical and corrosion resistance properties.

The typical grades offered by SKF are:

Inner ring

Corrosion-resistant steel

- 440C per AMS 5630
- PH13.8 per AMS 5629 H1000

Outer ring

- Corrosion-resistant steel 17-4PH per AMS 5643 H1150

Table 15 gives the different designations, reference standards and key characteristics for these materials.

For specific materials, refer to *Customized products* page 150.

Liner

SKF standard high-performance liner type X1-40 consists of woven PTFE yarns reinforced with structural fibres (**figure 24**).

This liner has been qualified to AS 81820, AS 81934 and EN 2755 and meets all of their technical requirements.

Refer to *Customized products* page 150 for other specific liner options

Surface coating

To enable improvement of endurance performance, SKF offers a range of surface coating technologies that can be applied to the inner ring spherical surface. Refer to the related product tables.

- XL
- XLHP
- XLNT

These coatings are tailored to extend life where the operating conditions are particularly demanding. Depending on operating conditions, bearing life can be improved by a factor in the order of 5 to 8 times.

These coatings enable bearing performance that meet and exceed the most demanding application requirements, such as those specified in AS 81819, AS 82819, AS 81820 Type A and ABS0576.

Contact SKF for further information and to select the most appropriate surface coating under specific application requirements.

Table 15

Standard bearing materials

Material type	Hardness HRC	Corrosion resistance	Material designation	EN	AMS	Equivalent designation
Corrosion-resistant steel	55 to 62	Good	440C	EN 2030	AMS 5630	X100CrMo17 (Z100CD17)
	28 to 37	Very good	17-4PH H1150	EN 2539 or EN 3161	AMS 5643	Z6CNU17.04 H1150
	≥ 43	Very good	PH13.8 H1000	-	AMS 5629	-

Figure 24

Liner material

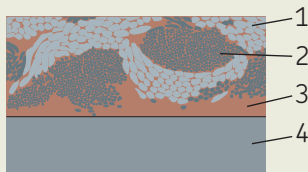

- 1 PTFE fibres
- 2 Structural fibres
- 3 Resin
- 4 Steel component



Surface treatments

Spherical plain bearings can be exposed to various environmental conditions including humidity, heat and contamination. These can increase the risk of corrosion and wear.

Therefore, SKF supplies spherical plain bearings with standard surface treatments including:

- Zinc-nickel or cadmium plating, on the outer ring external surfaces, typically to enhance corrosion resistance and/or fretting resistance
- Chromium plating¹⁾ or SKF's chromium replacement coating (XCR), in the spherical contact, typically used to enhance corrosion resistance and/or dynamic performance. SKF's XCR surface treatment is free from chromium 6 compounds and has equivalent performance in comparison to chromium plating

Corrosion-resistant steel inner rings can be passivated, as required by the relevant standards.

Surface treatments for SKF self-lubricating spherical plain bearings are applied according to the following standards:

- Passivation according to AMS 2700 or ISO 8075
- Cadmium plating¹⁾ according to AMS-QQ-P-416 or AMS03-19²⁾
- Zinc-nickel plating according to AMS 2417
- Hard chromium plating¹⁾ according to AMS 2460³⁾

The bearing interface dimensions and tolerances are not modified when surface treatments are used.

For specific surface treatments, please refer to *Customized products* **page 150**.

Dimensions and tolerances

Relevant interface dimensions and tolerances are listed in the product tables.

Where:

Δd_{mp} = Single plane mean bore diameter deviation

ΔD_{mp} = Single plane mean outside diameter deviation

Figure 25, top figure, shows a typical measurement method for a single plane mean diameter deviation.

And

Δd_s = Deviation of a single bore diameter

ΔD_s = Deviation of a single outside diameter

Figure 25, bottom figure, shows a typical measurement method for the deviation of a single diameter.

For more information about the measurement principle of interface dimensions and tolerances, refer to ISO 1132.

Sealing and shielding

Most spherical plain bearings can be supplied with seals or shields. Refer to the relevant product tables.

Seals and shields protect the spherical contact area against solid contaminants such as dust or sand. Seals should be considered in environments with high contamination. They can also protect against liquid contaminants such as hydraulic fluids or de-icing liquids.

The shields are fixed on the outer ring and are in close contact with the inner ring spherical surface. For sealed versions, seals are pressed between shields and the inner ring spherical surface (**figure 26**).

The geometrical, physical and mechanical characteristics of the sealed and shielded spherical plain bearings are identical to those of the unprotected bearings, except:

- The life under dynamic load in contaminated environments can be increased significantly
- The torque, especially for sealed bearings, can be increased
- The swivelling angle is reduced by 2 to 4° depending on the bearing type

Figure 25

Dimensional tolerances measurement principle

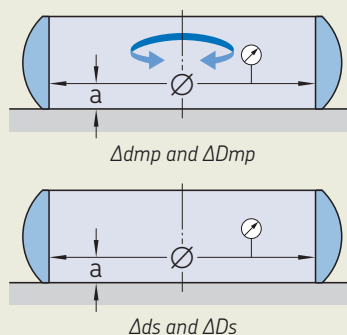
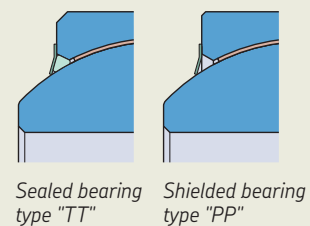

Figure 26

Bearing sealing and shielding solutions



¹⁾ Treatment includes chromium 6 compounds and may be subject to environmental legislation

²⁾ Formerly DEF STAN 03-19

³⁾ Formerly AMS QQ-C-320

Lined bore

Self-lubricating spherical plain bearings can be supplied with a self-lubricating liner in the bore (**figure 27**). This is suitable for applications requiring axial movements along the shaft or when a secondary rotational motion in the bore is needed.

The standard liner is the same as the one used on the spherical surface. For more information, refer to *Liner material* page 148.

The lined bore dimension, d_A and tolerance are listed in the relevant product tables.

Customized lined bore solutions can be supplied by SKF. Refer to *Customized products*.

Customized products

SKF designs and manufactures customized self-lubricating spherical plain bearings to meet specific application requirements.

Examples can include, but are not limited to:

- **Specific dimensions, clearances and geometries**
- **Materials**
 - Alternative steel and corrosion-resistant steel alloys
 - Coated titanium alloys and aluminium alloys for lightweight solutions
- **Surface treatments**
 - Including:
 - Silver plating
 - PVD

Certain treatments include chromium 6 compounds and may be subject to environmental legislation

- **Liners:**
 - Fiberslip
 - Textilub

Function	Typical SKF customized solutions
Axial stops	 <p>Screwed flange Nut and washer</p>
Geometries and designs	 <p>Special split longitudinal Counterbore, pockets, notches Ballpin</p>
Rotation and swivelling stops	 <p>Bump stops Pin</p>



Screwed flange

Nut and washer



Special split longitudinal

Counterbore, pockets, notches

Ballpin



Bump stops

Pin

Figure 27

Lined bore bearing

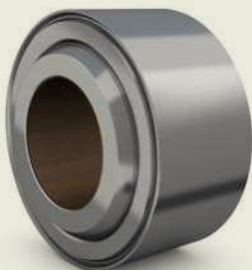
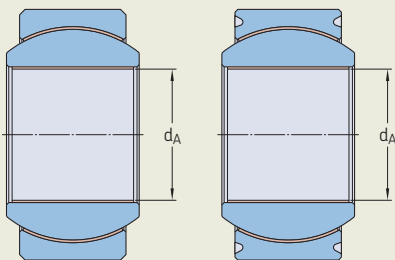

Legacy products

The following legacy series can still be supplied:

- 11AN..
- 11AW..
- ..SN
- ..SW

The legacy series listed in **table 16** are delivered and marked according to the listed cross-reference designation system (see also the relevant product tables):

Legacy standards

SKF can supply bearings compliant to the following legacy standards:

- AS 21230 to AS 21233

Customer standards

SKF can supply bearings compliant to the following customer standards:

- ASNA2121 to ASNA2124
- NSA 8134 to NSA 8137

Table 16

Cross-reference to legacy products

Variant	Cross-reference designation system	SKF Aerospace France designation system Lons-le-Saunier (formerly known as SARMA)	SKF Aerospace U.K. Limited designation system Clevedon (formerly known as AMPEP)
Light metric	LEN..	XRA..	11C..N.. (not plated) 11F..N.. (chromium plated sphere)
Narrow metric	NEN..	XRE..	11C..W.. (not plated) or 11F..W.. (chromium plated sphere) for bore code 5 and 22 11C..N.. (not plated) or 11F..N.. (chromium plated sphere) for bore code 6 and 10 11C..E.. (not plated) or 11F..E.. (chromium plated sphere) for bore code 8 and ≥ 12 (except 22)
Wide metric	WEN..	XRL..	11C..E.. (not plated) or 11F..E.. (chromium plated sphere) for bore code 5 11C..W.. (not plated) or 11F..W.. (chromium plated sphere) for bore code ≥ 6 11E..H (blended design inner ring)
High misalignment metric	HMEN..	RL..SP.. (stepped design inner ring)	
Narrow inch	NAS..	XRE..	11HN.. (inner ring sphere surface coated) 11BN..
Narrow inch lined bore	NAS..A..	XRE..A..	11LHN.. (inner ring sphere surface coated) 11LBN..
Wide inch	WAS..	XRL..	11HW.. (inner ring sphere surface coated) 11BW..
Wide inch lined bore	WAS..A..	XRL..A..	11LHW.. (inner ring sphere surface coated) 11LBW..

Bearing interfaces

Fits and tolerances

Spherical plain bearings are mounted with different fits on the shaft and in the housing:

- Shaft: Loose fit, typically 0 to +0,020 mm (0 to +0.0008 in)
- Housing: Depending on application requirements, **table 17**

The fit selection can affect the selection of the clearance or torque variant (**table 17**).

For example, when mounting with interference fit:

- For metal-to-metal spherical plain bearings, to avoid the removal of all the bearing clearance and risk of blocking the bearing, sufficient initial internal clearance is needed. Using a reduced clearance variant is therefore not recommended
- For self-lubricating spherical plain bearings, to avoid high torque increase and risk of blocking the bearing, reduced torque or controlled clearance variants should be used

Refer to *Friction and torque* **page 146** and *Internal clearance* **page 147** for more information.

The required bearing fits and resulting operating clearance and torque are influenced by the coefficients of thermal expansion of the housing and shaft materials if different than the bearing material. This effect must be considered when selecting fits and bearing initial internal clearance and torque.

2

Table 17

Housing fits for spherical plain bearings

Application conditions	Recommended fit	Recommended bearing variant		Effect on internal clearance or torque
		Metal-to-metal bearings	Self-lubricating bearings	
Risk for push-out, heavy load, matched assembly required	Interference fit −0,002 to −0,012 mm −0.0001 to −0.0005 in	Standard clearance	Reduced torque or controlled clearance	Moderate internal clearance reduction or torque increase
Accurate torque or clearance needed, low push-out risk, easy axial positioning needed	Loose fit with small clearance +0,025 to +0,010 mm +0.0010 to +0.0004 in	Standard or reduced clearance	Standard or reduced torque	Not affecting internal clearance nor torque
Accurate torque or clearance needed, low push-out risk, adhesive must be applied in the housing bore	Loose fit with large clearance +0,100 to +0,050 mm +0.0040 to +0.0020 in	Standard or reduced clearance	Standard or reduced torque	Not affecting internal clearance nor torque
Enable re-use of housing, matched assembly required for larger bearing outer diameters	Transition fit +0,020 to −0,005 mm +0.0008 to −0.0002 in	Standard or reduced clearance	Standard or reduced torque	Small internal clearance reduction or torque increase

Mounting

Mount spherical plain bearings in a clean environment and with care to achieve maximum performance and service life. Leave the bearings in their original packages until immediately before mounting so they are not exposed to any contaminants. Also, make sure mating components are clean before mounting the bearings.

Bearings should be mounted onto their shaft seats with a loose fit, refer to *Fits and tolerances* page 152. High interference fit could damage the inner ring and subsequently affect bearing performance.

When mounting a bearing in a housing, use an assembly tool which pushes on the outer ring whilst supporting both the outer and inner ring (figure 28).

When mounting a bearing on a shaft, use an assembly tool pushing on the inner ring while supporting the outer ring.

This is to ensure that the mounting force never acts on the sliding contact surfaces which could damage the bearing (figures 29 and 30).

It is possible to use a mechanical press to mount a bearing (figure 31). To avoid damage to the bearing, under no circumstances should a method involving shock load or impact be used (figure 32).

Bearings mounted with an interference fit should be assembled using a temperature difference between the bearing and housing (e.g. cooling the bearing with liquid nitrogen or refrigeration unit, or heating the housing) to ease assembly. The temperature used must stay between the permissible bearing temperature limits (For more information, refer to *Operating temperature* pages 138 and 147).

Depending on bearing mounting conditions, a retaining or a jointing compound can be used at the interface between the housing and the bearing outer ring:

- A retaining compound between the outer ring and housing can be used to maintain the bearing position. This is typically required for bearings fitted with a clearance fit in the housing. The effectiveness of the compound used should be tested to confirm its suitability for the application requirements
- To counteract fretting or galvanic corrosion between the metallic surfaces of the housing and the bearing outer ring, a jointing compound can be applied

Do not allow the retaining or jointing compound to enter the bearing or to obstruct the lubrication groove and holes in the outer ring of metal-to-metal spherical plain bearings.

Figure 28

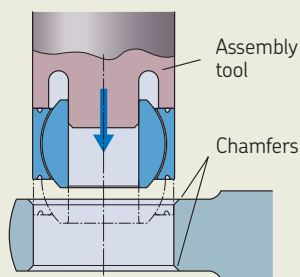

Figure 29

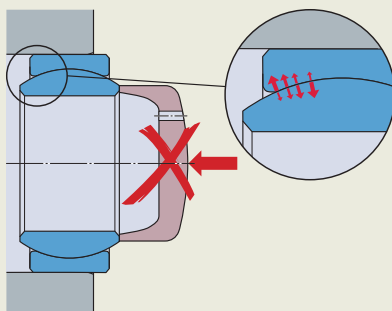

Figure 30

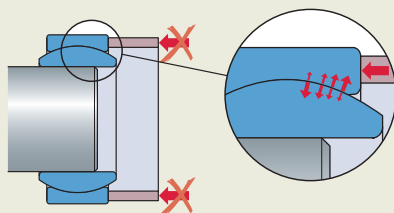

Figure 31

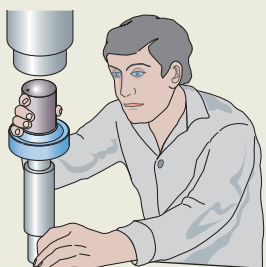
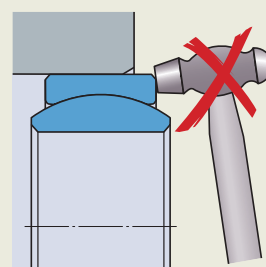

Figure 32



Bearing retention

Spherical plain bearings must be retained in the housing. Common solutions are described below.

The retention process can impact the bearing torque and/or internal clearance.

2

Anvil staking Process

- 1 Install bearing as detailed in *Mounting page 153*. Ensure the bearing is correctly axially centred in housing.
- 2 Determine the staking load required for bearing size and the housing material. Refer to *Staking and pushout load page 154*.
- 3 To confirm suitability of the staking loads, defined in step (2), slightly reduce the staking load and stake the first bearing from the batch using the following steps.
- 4 Position the bearing assembly on the location pin of the staking tool, as shown in **figure 33**. Apply the staking load and stake the first face.
- 5 Replace the lower anvil with a second staking head as shown in **figure 34**. Turn the bearing and housing over, locate the staked groove on the staking head and, applying the staking load, stake the second face.

- 6 Remove the bearing assembly, remove any surplus of retaining or jointing compound, and check rotational torque and axial retention.
- 7 If the staking acceptance criteria given in **page 154** are met, continue with the remaining components in the batch at the staking load established in step (3). If requirements are not met, adjust the staking load and repeat from step (4).

As an alternative to the above staking method, the staking of the two sides can be carried out in one step (omitting the staking anvil step in (4) above). This alternative should not be applied if a clearance fit is used.

Staking acceptance

After staking, the staked lip should be inspected for any damage, cracking or incomplete staking areas.

Two main criteria can be used to validate the staking:

- Check the retaining strength of the staked lip. The installed bearing can be axially proof loaded (For more information, refer to *Staking and pushout load* below). Loads must be applied through the outer ring of the bearing and not through the inner ring
- Check the gap between the lip and housing chamfer. This should be checked with a feeler gauge and should not exceed 0.127 mm (0.005 in) over 40% of the staking lip circumference. See **figure 35**.

Staking and pushout load

For additional information about staking of standard bearings, refer to the relevant standards, including TR 4541, MIL-HDBK-1599, NAS 0331, NFL 31-081 and NFL 31-083.

Figure 33

Tooling arrangement first stage stake

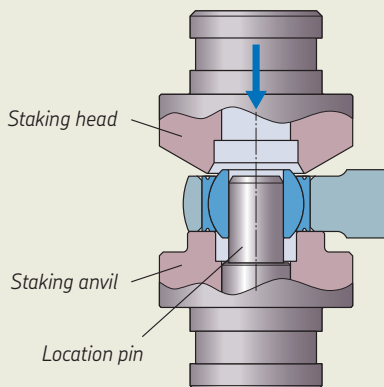

Figure 34

Tooling arrangement final stage stake

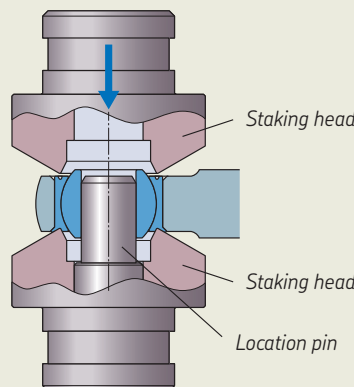
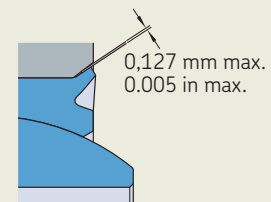

Figure 35

Staking gauge control



Roller staking

Roller staking is another lip deforming method. This is carried out using a rotating head with rotating discs or rollers running in the staking groove, which deform the outer ring lip.

Threaded or bolted retention plate

Spherical plain bearings with chamfered outer rings can be retained in the housing by using either a threaded or bolted plate (**figure 36**). This method improves axial load carrying capabilities and eases assembly and bearing replacement but increases weight and requires more space.

For mounting of customized designs, such as screwed flanges, refer to *Customized products* **page 141** and **150**.

Dismounting

Spherical plain bearings can be removed by pushing the bearing out of its housing.

The removal of bearings retained by staking can be facilitated if one retaining lip is machined away before pressing the bearing out. Care must be taken not to damage the housing.

A typical dismounting method is shown in **figure 37**.

A dismounted bearing should not be reused.

SKF supplies bearings with oversized outer diameters in a range of increments to allow bearing replacement in housings.

The housing should be thoroughly cleaned of any hardened retaining or jointing compound. The housing bore can also be re-machined and should be verified dimensionally before the new bearing is installed, especially if fretting damage is evident.

Storage

The conditions under which bearings, seals and lubricants are stored can have an adverse effect on their performance. Inventory control can also play an important role in performance, particularly for bearings having seals and lubricants. Therefore, SKF recommends a “first in, first out” inventory policy.

Storage conditions

To maintain the integrity of the product during storage, SKF recommends the following basic housekeeping practices (**table 18**):

- Store bearings in a stable, clean, vibration-free, and dry area with a cool, and steady temperature
- Control and limit relative humidity in the storage area
- Keep bearings in their original unopened packages until immediately prior to mounting to prevent risk of bearing deterioration such as the ingress of contaminants

After 5 years of storage, the grease in metal-to-metal bearings ages and must be changed by SKF.

For storage outside these conditions, the stated storage life is not guaranteed. Contact SKF for more information.

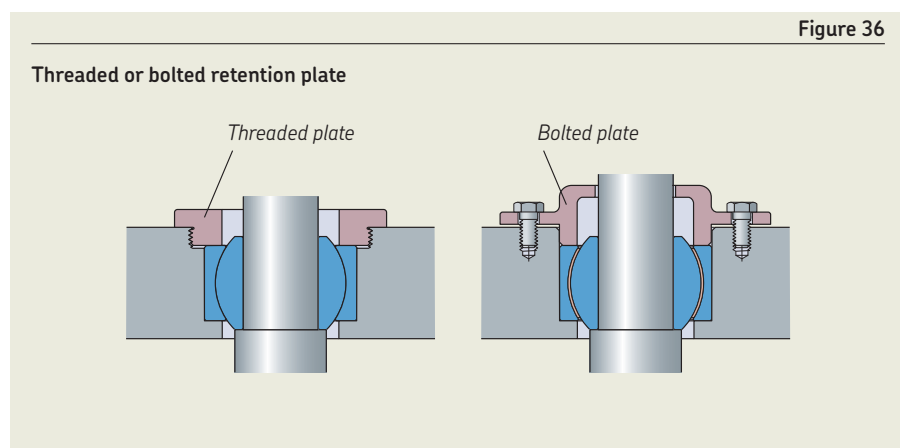
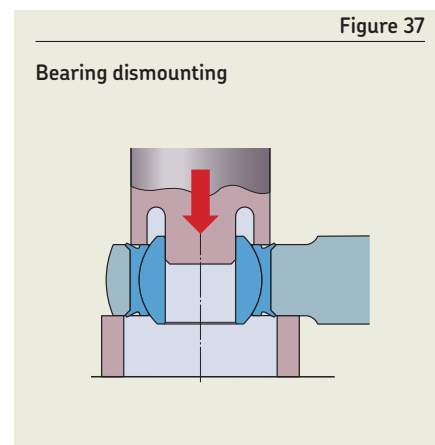

Table 18

Bearing storage conditions

Standard	Metal-to-metal bearings	Self-lubricating bearings
Storage life	5 years	15 years ¹⁾
Storage temperature	15 to 35 °C (55 to 95 °F)	15 to 25 °C (55 to 77 °F)
Relative humidity	50 to 70%	50 to 70%

¹⁾ Can be limited by specific combinations of surface treatment and marking technology. Always refer to the dates indicated on SKF's packaging. Contact SKF for more information.



2.1 Metal-to-metal loader slot (metric dimensions)

GE.. bore code 4 to 20

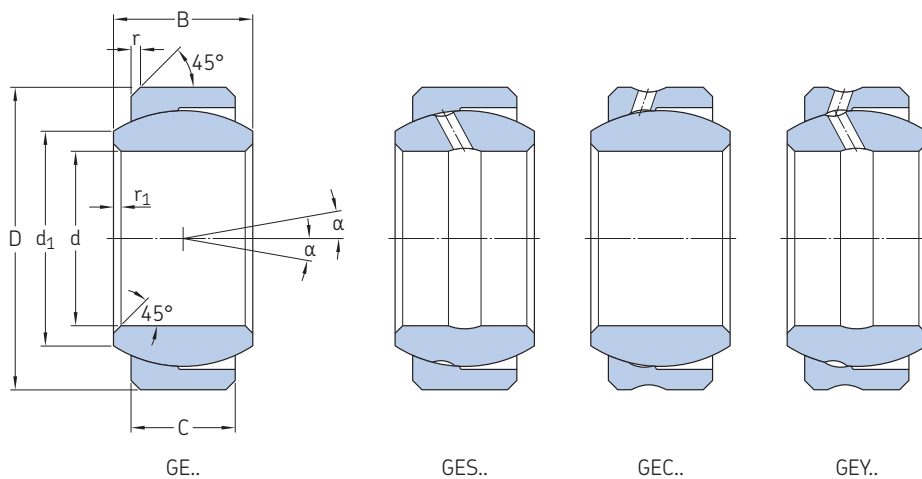

Technical specification	EN 2337
Product standards	EN 2336 (Bearing steel) EN 2588 (Corrosion-resistant steel)
Surface treatment	For products with inner and outer rings in bearing steel or corrosion-resistant steel, one of the spherical surfaces is treated with molybdenum disulfide

Dimensions

Nominal bore code	Dimensions		Δds	D	ΔDmp	ΔDs	C 0/-0,25	B 0/-0,06
	d	Δdmp						
–	mm	μm		mm	μm		mm	
4 ¹⁾	4	0/-8	+2/-10	12	0/-8	+5/-13	3	5
5	5	0/-8	+2/-10	14	0/-8	+5/-13	4	6
6	6	0/-8	+2/-10	14	0/-8	+5/-13	4	6
8	8	0/-8	+2/-10	16	0/-8	+5/-13	5	8
10	10	0/-8	+2/-10	19	0/-9	+6/-15	6	9
12	12	0/-8	+3/-11	22	0/-9	+6/-15	7	10
15	15	0/-8	+3/-11	26	0/-9	+6/-15	9	12
17	17	0/-8	+3/-11	30	0/-11	+8/-19	10	14
20	20	0/-10	+3/-13	35	0/-11	+8/-19	12	16

Dimensions cont., loads and clearance

Nominal bore code	Dimensions		r_1	α^3	Mass ≈	Static limit loads ²⁾		Axial clearance		Radial clearance max	
	d_1 ≈	r				Radial C_s	Axial C_a	Standard	Reduced	Standard	Reduced
–	mm			°	g	kN		μm			
4 ¹⁾	6,2	0,4/0,7	0,3/0,6	16	3	7,7	0,45	30/60	1/30	15	8
5	8	0,4/0,7	0,3/0,6	13	4	14	0,8	30/60	1/30	15	8
6	8	0,4/0,7	0,3/0,6	13	4	17,5	1	30/60	1/30	15	8
8	10,2	0,5/0,8	0,5/0,8	15	8	27	1,8	30/60	1/30	15	8
10	13,2	0,5/0,8	0,5/0,8	12	12	44	2,5	30/60	1/30	15	8
12	16	0,6/1	0,5/0,8	11	17	57	3,5	30/60	1/30	15	8
15	18,5	0,6/1	0,5/0,8	9	32	87	5,3	30/60	1/30	15	8
17	20,7	0,9/1,3	0,7/1,1	10	54	112	6,7	30/60	1/30	15	8
20	24,1	0,9/1,3	0,7/1,1	9	65	162	9,8	30/60	1/30	15	8

¹⁾ SKF option

²⁾ Loads are given in the opposite direction to the slots and are valid for the steel/steel spherical plain bearings without lubrication groove. For other bearings, refer to page 134

³⁾ Values are given for non protected bearings. For sealed bearings, refer to page 140



Designation system

Examples:	ZWGES20D-C2A-2CP6R10	Z	W	GE	S	20	D-C2A	E	-2	CP6	R10
	QGEC30EE										
Surface treatment of outer ring											
No code	Not plated										
Z¹⁾	Cadmium plated external dimensions										
SZ¹⁾	Zinc-nickel plated external dimensions										
Material											
No code	Bearing steel inner ring and outer ring										
W	Corrosion-resistant steel inner ring and outer ring										
Q¹⁾	Bronze beryllium inner ring and bearing steel outer ring										
Basic designation											
Lubrication grooves											
No code	Without lubrication groove										
S	Lubrication by inner ring										
C³⁾	Lubrication by outer ring										
Y¹⁾	Lubrication by inner and outer ring										
Bore code											
Clearance code	Axial clearance										
D-C2A	Standard										
No code¹⁾	Reduced										
D¹⁾	Standard										
D-C1A¹⁾	No requirement										
-C3A	Reduced										
	Radial clearance										
	Standard										
	No requirement										
	No requirement										
	Reduced										
	Reduced										
Seal											
No code	No seal										
E⁴⁾	Sealed on the slot side										
EE⁴⁾	Sealed on both sides										
Lubricant											
No code	Grease G354										
-2	Grease G395										
Surface treatment of inner ring sphere											
No code	Not plated										
CP6⁵⁾	Chromium plated sphere										
CP109⁵⁾	XCR plating on sphere (chromium 6 free replacement to chromium plating)										
CP55²⁾	Passivated corrosion-resistant steel inner ring										
Oversize											
No code	Standard outer diameter size										
R10¹⁾	0,1 mm oversized outer diameter										
R20¹⁾	0,2 mm oversized outer diameter										

1) SKF option

2) Available only for inner ring in corrosion-resistant steel

3) In the outer ring sphere, central lubrication groove only for $d \leq 6$

4) Only available for $d \geq 6$

5) SKF option, available only for inner ring in corrosion-resistant steel

2.1 Metal-to-metal loader slot (metric dimensions)

GE.. bore code 25 to 80

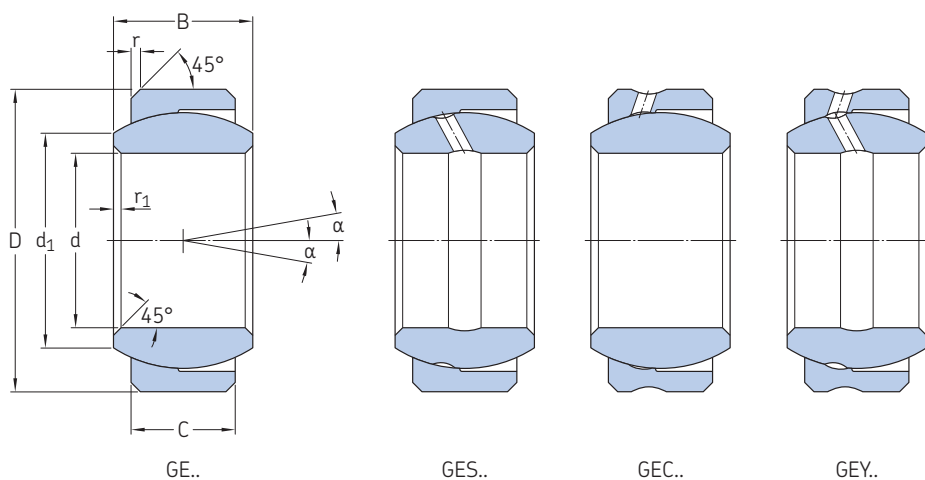

Technical specification	EN 2337
Product standards	EN 2336 (Bearing steel) EN 2588 (Corrosion-resistant steel)
Surface treatment	For products with inner and outer rings in bearing steel or corrosion-resistant steel, one of the spherical surfaces is treated with molybdenum disulfide

Dimensions

Nominal bore code	Dimensions		Δd_{mp}	Δd_s	D	ΔD_{mp}	ΔD_s	C 0/-0,25	B 0/-0,06
	d								
–	mm	μm			mm	μm		mm	
25	25	0/-10	+3/-13	42	0/-11	+8/-19	16	20	
30	30	0/-10	+3/-13	47	0/-11	+8/-19	18	22	
35	35	0/-12	+3/-15	55	0/-13	+10/-23	20	25	
40	40	0/-12	+3/-15	62	0/-13	+10/-23	22	28	
45	45	0/-12	+3/-15	68	0/-13	+10/-23	25	32	
50	50	0/-12	+3/-15	75	0/-13	+10/-23	28	35	
60	60	0/-15	+4/-19	90	0/-15	+13/-28	36	44	
70	70	0/-15	+4/-19	105	0/-15	+13/-28	40	49	
80	80	0/-15	+4/-19	120	0/-15	+13/-28	45	55	

Dimensions cont., loads and clearance

Nominal bore code	Dimensions		r_1	α^2	Mass \approx	Static limit loads ¹⁾		Axial clearance		Radial clearance max	
	$d_1 \approx$	r				Radial C_s	Axial C_a	Standard	Reduced	Standard	Reduced
–	mm			°	g	kN		μm			
25	29,3	0,9/1,3	0,7/1,1	7	115	270	18	30/60	1/30	15	8
30	34,2	0,9/1,3	0,7/1,1	6	160	393	25	30/60	1/30	15	8
35	39,8	0,9/1,3	0,7/1,1	7	229	508	31	40/80	1/40	20	10
40	45	1,4/1,8	1,2/1,7	7	315	637	38	40/80	1/40	20	10
45	50,8	1,4/1,8	1,2/1,7	7	460	825	50	40/80	1/40	20	10
50	55,9	1,4/1,8	1,2/1,7	7	560	1 017	64	40/80	1/40	20	10
60	66,8	1,4/1,8	1,2/1,7	6	1 100	1 584	104	50/100	1/50	25	15
70	77,8	1,4/1,8	1,2/1,7	6	1 540	2 013	128	50/100	1/50	25	15
80	89,4	1,4/1,8	1,2/1,7	6	2 290	2 640	163	50/100	1/50	25	15

¹⁾ Loads are given in the opposite direction to the slots and are valid for the steel/steel spherical plain bearings without lubrication groove. For other bearings, refer to page 134

²⁾ Values are given for non protected bearings. For sealed bearings, refer to page 140



Designation system

Examples:	ZWGES20D-C2A-2CP6R10	Z	W	GE	S	20	D-C2A	E	-2	CP6	R10
	QGEC30EE										
Surface treatment of outer ring											
No code	Not plated										
Z¹⁾	Cadmium plated external dimensions										
SZ¹⁾	Zinc-nickel plated external dimensions										
Material											
No code	Bearing steel inner ring and outer ring										
W	Corrosion-resistant steel inner ring and outer ring										
Q¹⁾	Bronze beryllium inner ring and bearing steel outer ring										
Basic designation											
Lubrication grooves											
No code	Without lubrication groove										
S	Lubrication by inner ring										
C³⁾	Lubrication by outer ring										
Y¹⁾	Lubrication by inner and outer ring										
Bore code											
Clearance code	Axial clearance										
D-C2A	Standard	Radial clearance	Standard								
No code¹⁾	Reduced		No requirement								
D¹⁾	Standard		No requirement								
D-C1A¹⁾	No requirement		Reduced								
-C3A	Reduced		Reduced								
Seal											
No code	No seal										
E⁴⁾	Sealed on the slot side										
EE⁴⁾	Sealed on both sides										
Lubricant											
No code	Grease G354										
-2	Grease G395										
Surface treatment of inner ring sphere											
No code	Not plated										
CP6⁵⁾	Chromium plated sphere										
CP109⁵⁾	XCR plating on sphere (chromium 6 free replacement to chromium plating)										
CP55²⁾	Passivated corrosion-resistant steel inner ring										
Oversize											
No code	Standard outer diameter size										
R10¹⁾	0,1 mm oversized outer diameter										
R20¹⁾	0,2 mm oversized outer diameter										

1) SKF option

2) Available only for inner ring in corrosion-resistant steel

3) In the outer ring sphere, central lubrication groove only for $d \leq 6$

4) Only available for $d \geq 6$

5) SKF option, available only for inner ring in corrosion-resistant steel

2.2 Metal-to-metal loader slot normal (metric dimensions)

GL..., GLD..., GLS... and GLS..TAG bore code 4 to 17/30

Technical specification –
Product standards –

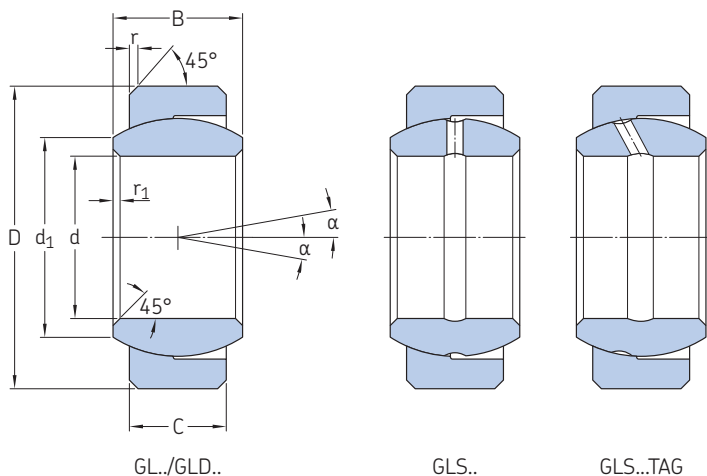

Dimensions

Nominal bore code	Dimensions		GLS..TAG only	D	ΔD_{mp} GL..., GLD.. and GLS..	GLS..TAG only	C h11	B h11
	d	Δd_{mp} GL..., GLD.. and GLS..						
–	mm	μm		mm	μm		mm	
4	4	0/-8	–	12	0/-8	–	3	5
5	5	0/-8	–	14	0/-8	–	4	6
6	6	0/-8	–	14	0/-8	–	4	6
8/16	8	0/-8	–	16	0/-8	–	5	8
8	8	0/-8	–	17	0/-8	–	5	8
10/19	10	0/-8	–	19	0/-9	–	6	9
10	10	0/-8	–	20	0/-9	–	6	9
12	12	0/-8	+11/0	22	0/-9	0/-9	7	10
14	14	0/-8	+11/0	25	0/-9	0/-9	8	11
15/26	15	0/-8	+11/0	26	0/-9	0/-9	9	12
15	15	0/-8	+11/0	28	0/-9	0/-9	9	12
16	16	0/-8	+11/0	28	0/-9	0/-9	9	12
17	17	0/-8	+11/0	32	0/-11	0/-11	10	14
17/30	17	0/-8	+11/0	30	0/-11	0/-11	10	14

Dimensions cont., loads and clearance

Nominal bore code	Dimensions			$\alpha^2)$	Mass ≈	Static limit loads ¹⁾		Axial clearance				
	d ₁ ≈	r GL..., GLD.. and GLS..	r ₁ GLS..TAG only +0,3/0			Radial C _s	Axial C _a	GL..	GLD.. and GLS..	GLS..TAG		
–	mm			°	g	kN		μm				
4	6,2	0,4/0,8	0,4/0,7	–	–	16	3	7,7	0,45	0/30	30/60	–
5	8	0,4/0,8	0,4/0,7	–	–	13	4	14	0,8	0/30	30/60	–
6	8	0,4/0,8	0,4/0,7	–	–	13	4	17,5	1	0/30	30/60	–
8/16	10,2	0,4/0,8	0,4/0,7	–	–	15	8	27	1,8	0/30	30/60	–
8	10,2	0,4/0,8	0,4/0,7	–	–	15	10	27	1,8	0/30	30/60	–
10/19	13,2	0,4/0,8	0,5/0,8	–	–	12	12	44	2,5	0/30	30/60	–
10	13,2	0,4/0,8	0,5/0,8	–	–	12	13	44	2,5	0/30	30/60	–
12	14,9	0,7/1,2	0,5/0,8	0,7	0,5	11	17	57	3,5	0/30	30/60	5/15
14	16,7	0,7/1,2	0,5/0,8	0,7	0,5	10	22	60	4	0/30	30/60	5/15
15/26	18,5	0,7/1,2	0,5/0,8	0,7	0,5	9	32	87	5,3	0/30	30/60	5/15
15	18,5	0,7/1,2	0,5/0,8	0,7	0,5	9	34	87	5,3	0/30	30/60	5/15
16	18,5	0,7/1,2	0,5/0,8	0,7	0,5	9	33	87	5,3	0/30	30/60	5/15
17	20,7	0,9/1,3	0,7/1,1	1	0,5	10	52	112	6,7	0/30	30/60	5/15
17/30	20,7	0,9/1,3	0,7/1,1	1	0,5	10	54	112	6,7	0/30	30/60	5/15

¹⁾ Loads are given in the opposite direction to the slots and are valid for the steel/steel spherical plain bearings without lubrication groove. For other bearings, refer to page 134

²⁾ Values are given for non protected bearings. For sealed bearings, refer to page 140



Designation system

Examples: ZWGLS20TAGE-2CP6R10
QGLD15/26EE

Surface treatment of outer ring

No code Not plated
Z Cadmium plated external dimensions
SZ Zinc-nickel plated external dimensions

Material

No code Bearing steel inner ring and outer ring
W Corrosion-resistant steel inner ring and outer ring
Q Bronze beryllium inner ring and bearing steel outer ring

Basic designation

Lubrication grooves and axial clearance

No code Without lubrication groove and reduced axial clearance
D Without lubrication groove and standard axial clearance
S Lubrication by inner ring (vertical groove) and standard axial clearance
S..TAG¹⁾ Lubrication by inner ring (inclined groove) and reduced axial clearance

Bore code

Seal

No code No seal
E³⁾ Sealed on the slot side
EE³⁾ Sealed on both sides

Lubricant

No code Grease G354
-2 Grease G395

Surface treatment of inner ring

No code Not plated
CP6²⁾ Chromium plated sphere
CP109²⁾ XCR plating on sphere (chromium 6 free replacement to chromium plating)
CP55²⁾ Passivated corrosion-resistant steel inner ring

Oversize

No code Standard outer diameter size
R10 0,1 mm oversized outer diameter
R20 0,2 mm oversized outer diameter

¹⁾ Only available for bore code ≥ 12 and ≤ 50

²⁾ Available only for inner ring in corrosion-resistant steel material

³⁾ Only available for $d \geq 6$

2.2 Metal-to-metal loader slot normal (metric dimensions)

GL..., GLD..., GLS... and GLS..TAG bore code **20 to 80**

Technical specification	-
Product standards	-

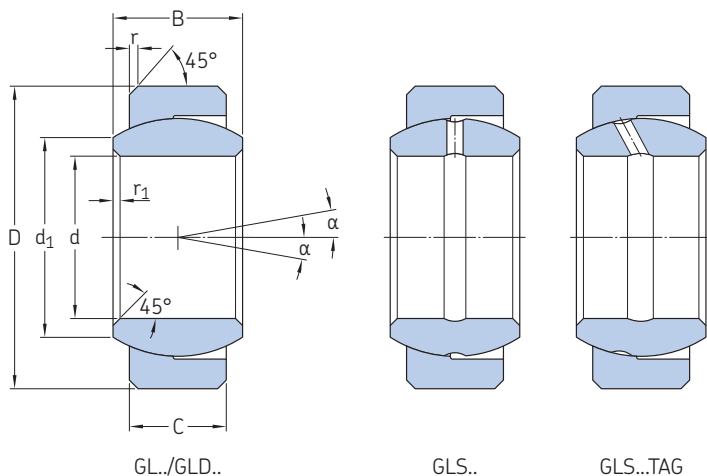

Dimensions

Nominal bore code	Dimensions			D	ΔD_{mp} GL..., GLD... and GLS..	GLS..TAG only	C h11	B h11
	d	Δd_{mp} GL..., GLD... and GLS..	GLS..TAG only					
-	mm	μm		mm	μm		mm	
20	20	0/-10	+13/0	35	0/-11	0/-11	12	16
25	25	0/-10	+13/0	42	0/-11	0/-11	16	20
30/47	30	0/-10	+13/0	47	0/-11	0/-11	18	22
35	35	0/-12	+16/0	55	0/-13	0/-13	20	25
40	40	0/-12	+16/0	62	0/-13	0/-13	22	28
45/68	45	0/-12	+16/0	68	0/-13	0/-13	25	32
50	50	0/-12	+16/0	75	0/-13	0/-13	28	35
55	55	0/-15	-	85	0/-15	-	32	40
60	60	0/-15	-	90	0/-15	-	36	44
70	70	0/-15	-	105	0/-15	-	40	49
80	80	0/-15	-	120	0/-15	-	45	55

Dimensions cont., loads and clearance

Nominal bore code	Dimensions			r	r1	$\alpha^{2)}$	Mass ≈	Static limit loads ¹⁾		Axial clearance		
	d1 ≈	r GL..., GLD... and GLS..	r1 GLS..TAG only +0,3/0					Radial Cs	Axial Ca	GL..	GLD.. and GLS..	GLS..TAG
-	mm					°	g	kN		μm		
20	24,1	0,9/1,3	0,7/1,1	1	0,5	9	65	162	9,8	0/30	30/60	10/20
25	29,3	0,9/1,3	0,7/1,1	1	0,5	7	115	270	18	0/30	30/60	10/20
30/47	34,2	0,9/1,3	0,7/1,1	1	0,5	6	160	393	25	0/30	30/60	10/20
35	39,8	0,9/1,3	0,7/1,1	1	0,5	7	229	508	31	0/40	40/80	10/20
40	45	1,2/1,7	1,2/1,7	1,5	0,5	7	315	637	38	0/40	40/80	10/20
45/68	50,8	1,2/1,7	1,2/1,7	1,5	0,5	7	460	825	50	0/40	40/80	10/20
50	55,9	1,2/1,7	1,2/1,7	1,5	0,5	7	560	1 017	64	0/40	40/80	10/20
55	62,2	1,2/1,7	1,2/1,7	-	-	7	805	1 297	82	0/50	50/100	-
60	66,8	1,2/1,7	1,2/1,7	-	-	6	1 100	1 584	104	0/50	50/100	-
70	77,8	1,2/1,7	1,2/1,7	-	-	6	1 540	2 013	128	0/50	50/100	-
80	89,4	1,2/1,7	1,2/1,7	-	-	6	2 200	2 640	163	0/50	50/100	-

¹⁾ Loads are given in the opposite direction to the slots and are valid for the steel/steel spherical plain bearings without lubrication groove. For other bearings, refer to page 134

²⁾ Values are given for non protected bearings. For sealed bearings, refer to page 140



Designation system

Examples: ZWGLS20TAGE-2CP6R10
QGLD15/26EE

Z W GL S 20 TAG E -2 CP6 R10

Surface treatment of outer ring

No code Not plated
Z Cadmium plated external dimensions
SZ Zinc-nickel plated external dimensions

Material

No code Bearing steel inner ring and outer ring
W Corrosion-resistant steel inner ring and outer ring
Q Bronze beryllium inner ring and bearing steel outer ring

Basic designation

Lubrication grooves and axial clearance

No code Without lubrication groove and reduced axial clearance
D Without lubrication groove and standard axial clearance
S Lubrication by inner ring (vertical groove) and standard axial clearance
S..TAG¹⁾ Lubrication by inner ring (inclined groove) and reduced axial clearance

Bore code

Seal

No code No seal
E³⁾ Sealed on the slot side
EE³⁾ Sealed on both sides

Lubricant

No code Grease G354
-2 Grease G395

Surface treatment of inner ring

No code Not plated
CP6²⁾ Chromium plated sphere
CP109²⁾ XCR plating on sphere (chromium 6 free replacement to chromium plating)
CP55²⁾ Passivated corrosion-resistant steel inner ring

Oversize

No code Standard outer diameter size
R10 0,1 mm oversized outer diameter
R20 0,2 mm oversized outer diameter

¹⁾ Only available for bore code ≥ 12 and ≤ 50

²⁾ Available only for inner ring in corrosion-resistant steel material

³⁾ Only available for $d \geq 6$

2.3 Metal-to-metal loader slot normal reinforced (metric dimensions)

GLS..RTG

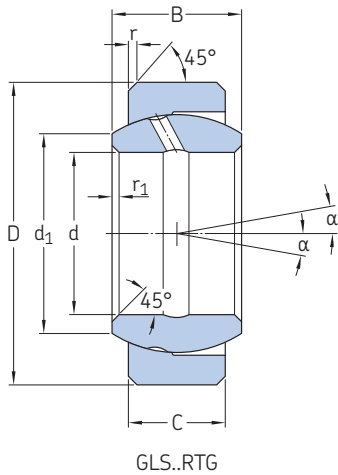

Technical specification -

Product standards -

Dimensions

Nominal bore code	Dimensions		D	ΔD_{mp} h5	C h11	B 0/-0,05
	d	Δd_{mp} H6				
-	mm	μm	mm	μm	mm	
12	12	+11/0	25	0/-9	9	12
14	14	+11/0	28	0/-9	9	13
15	15	+11/0	32	0/-11	10	14
16	16	+11/0	32	0/-11	10	14
17	17	+11/0	35	0/-11	13	17
20	20	+13/0	42	0/-11	16	20
25	25	+13/0	47	0/-11	18	22
30	30	+13/0	55	0/-13	20	25
35	35	+16/0	62	0/-13	22	28
40	40	+16/0	68	0/-13	25	32
45	45	+16/0	75	0/-13	28	35
50	50	+16/0	85	0/-15	32	40

Dimensions cont., loads and clearance

Nominal bore code	Dimensions			$\alpha^{2)}$	Mass ≈	Static limit loads ¹⁾		Axial clearance
	d ₁ ≈	r +0,3/0	r ₁ +0,3/0			Radial C _s	Axial C _a	
-	mm			°	g	kN		μm
12	17,2	0,7	0,5	10	30	65	4,1	30/60
14	20,2	0,7	0,5	11	39	77	4,2	30/60
15	21,9	0,7	0,5	10	56	96	5,1	30/60
16	21,9	0,7	0,5	10	53	96	5,1	30/60
17	24,7	1	0,5	9	83	144	9	30/60
20	29,3	1	0,5	8	144	216	14,2	30/60
25	34,2	1	0,5	7	187	322	20,5	30/60
30	39,8	1	0,5	7	279	462	28	30/60
35	45,0	1	0,5	7°30	380	637	38	40/80
40	50,8	1,5	0,5	8	503	825	49,5	40/80
45	56,0	1,5	0,5	8	660	1 017	63,5	40/80
50	62,3	1,5	0,5	7	986	1 297	82	40/80

¹⁾ Loads are given in the opposite direction to the slots and are valid for the steel/steel spherical plain bearings. For other bearings, refer to page 134

²⁾ Values are given for non protected bearings. For sealed bearings, refer to page 140



Designation system

Examples:	ZWGLS20MRTGE-2CP6R10	Z	W	GLS	20	M	RTG	E	-2	CP6	R10
	QGLS12RTGEE										
Surface treatment of outer ring											
No code	Not plated										
Z	Cadmium plated external dimensions										
SZ	Zinc-nickel plated external dimensions										
Material											
No code	Bearing steel inner ring and outer ring										
W	Corrosion-resistant steel inner ring and outer ring										
Q	Bronze beryllium inner ring and bearing steel outer ring										
Basic designation											
Bore code											
Dry-lubricant											
No code	No treatment										
M	With molybdenum disulfide										
Seal											
No code	No seal										
E	Sealed on the slot side										
EE	Sealed on both sides										
Lubricant											
No code	Grease G354										
-2	Grease G395										
Surface treatment of inner ring sphere											
No code	Not plated										
CP6 ¹⁾	Chromium plated sphere										
CP109 ¹⁾	XCR plating on sphere (chromium 6 free replacement to chromium plating)										
CP55 ¹⁾	Passivated corrosion-resistant steel inner ring										
Oversize											
No code	Standard outer diameter size										
R10	0,1 mm oversized outer diameter										
R20	0,2 mm oversized outer diameter										

¹⁾ Available only for inner ring in corrosion-resistant steel material

2.4 Metal-to-metal loader slot wide (metric dimensions)

GT

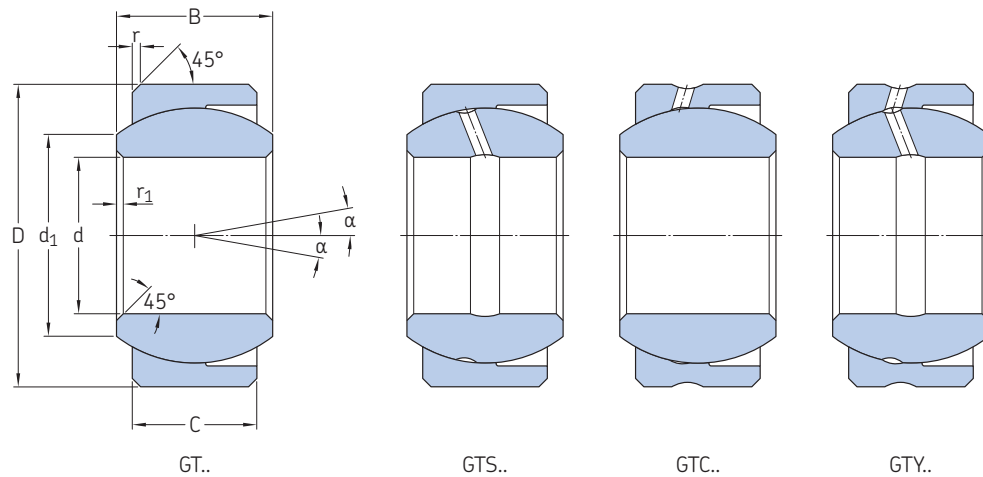

Technical specification -
Product standards -

Dimensions

Nominal bore code	Dimensions		D	ΔD_{mp}	C ± 1	B 0/-0,06
	d	Δd_{mp}				
-	mm	μm	mm	μm	mm	
12	12	0/-8	25	0/-8	10	13
15	15	0/-8	29	0/-8	12	15
17	17	0/-8	31	0/-9	13,5	16
20	20	0/-9	40	0/-9	18	22
25	25	0/-9	45	0/-9	20	25
30	30	0/-9	51	0/-11	24	28
35	35	0/-11	57	0/-11	26	31
40	40	0/-11	64	0/-11	29	34
45	45	0/-11	72	0/-11	32	37
50	50	0/-11	80	0/-13	34	41

Dimensions cont., loads and clearance

Nominal bore code	Dimensions		r_1 +0,3/0	$\alpha^{2)}$	Mass =	Static limit loads ¹⁾		Axial clearance	
	$d_1 \approx$	r +0,3/0				Radial C_s	Axial C_a	GT	GTS GTC GTY
-	mm			°	g	kN		μm	
12	16,2	0,5	0,1	10	31	91,8	6,2	5/25	15/40
15	19,2	0,5	0,1	8	49	133,8	9,4	5/25	15/40
17	20,7	0,5	0,1	7	57	162,6	15,7	5/25	15/40
20	25,4	0,7	0,1	8	135	274,8	22,6	10/30	20/45
25	29,7	0,7	0,1	8	180	361,8	28,5	10/30	20/45
30	34,7	0,7	0,1	6	290	555	45,8	10/30	20/45
35	39,2	0,9	0,1	7	325	684,4	54	15/40	25/50
40	45,2	0,9	0,1	6	440	887	67,6	15/40	25/50
45	51,5	0,9	0,1	5	605	1 105	83,1	15/40	25/50
50	57	0,9	0,1	7	840	1 304	93,6	15/50	25/50

¹⁾ Loads are given in the opposite direction to the slots and are valid for the steel/steel spherical plain bearings without lubrication groove. For other bearings, refer to page 134

²⁾ Values are given for non protected bearings. For sealed bearings, refer to page 140



Designation system

Examples:	ZWGT S 20 E -2 CP6 R10	Z	W	GT	S	20	E	-2	CP6	R10
Surface treatment of outer ring										
No code	Not plated									
Z	Cadmium plated external dimensions									
SZ	Zinc-nickel plated external dimensions									
Material										
No code	Bearing steel inner ring and outer ring									
W	Corrosion-resistant steel inner ring and outer ring									
Q	Bronze beryllium inner ring and bearing steel outer ring									
Basic designation										
Lubrication grooves and axial clearance										
No code	Without lubrication groove and reduced axial clearance									
Code S	Lubrication by inner ring and standard axial clearance									
Code C	Lubrication by outer ring and standard axial clearance									
Code Y	Lubrication by inner and outer ring and standard axial clearance									
Bore code										
Seal										
No code	No seal									
E	Sealed on the slot side									
EE	Sealed on both sides									
Lubricant										
No code	Grease G354									
-2	Grease G395									
Surface treatment of inner ring										
No code	Not plated									
CP6 ¹⁾	Chromium plated sphere									
CP109 ¹⁾	XCR plating on sphere (chromium 6 free replacement to chromium plating)									
CP55 ¹⁾	Passivated corrosion-resistant steel inner ring									
Oversize										
No code	Standard outer diameter size									
R10	0,1 mm oversized outer diameter									
R20	0,2 mm oversized outer diameter									

¹⁾ Available only for inner ring in corrosion-resistant steel material

2.5 Metal-to-metal swaged light (metric dimensions)

MA bore code 4 to 20

Technical specification EN 2337
Product standards EN 2335
Surface treatment For products with inner and outer rings in corrosion-resistant steel, one of the spherical surfaces is treated with molybdenum disulfide

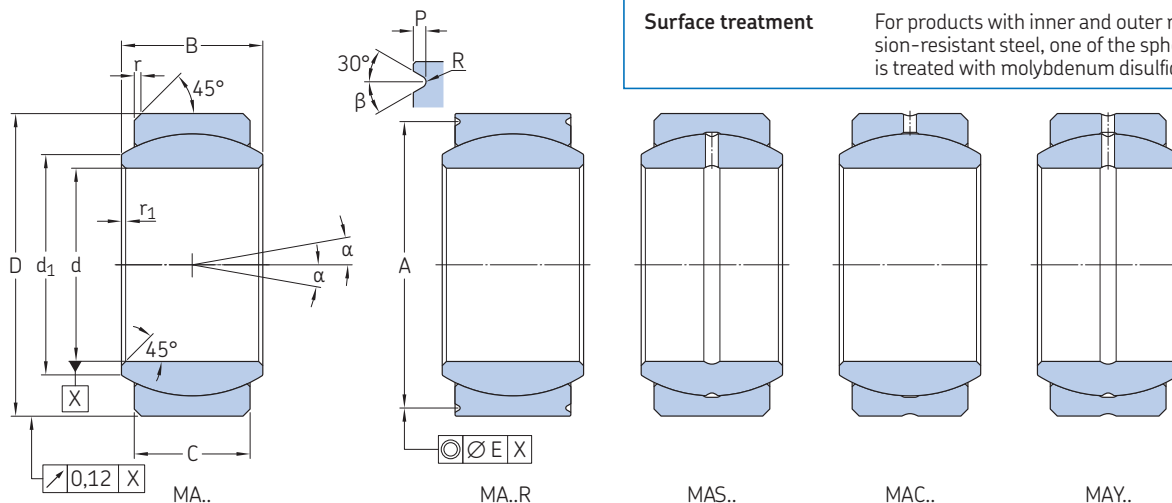

β	E
°	mm
30	0,12

Dimensions

Nominal bore code	Dimensions		D	ΔDmp	ΔDs	C ±0.1	B 0/-0,06	d ₁ ≈	A +0,1/0 Code R	Code PR	
	d	Δdmp									Δds
–	mm	μm	mm	μm	mm	mm	mm	mm	mm	mm	
4	4	0/-8	+3/-10	12	0/-8	+5/-13	3	5	6,2	–	–
5	5	0/-8	+3/-10	14	0/-8	+5/-13	4	6	8	–	–
6	6	0/-8	+3/-10	14	0/-8	+5/-13	4	6	8	–	–
8	8	0/-8	+3/-10	16	0/-8	+5/-13	5	8	10,2	14,2	–
10	10	0/-8	+3/-10	19	0/-9	+6/-15	6	9	13,2	17,2	–
12	12	0/-8	+3/-11	22	0/-9	+6/-15	7	10	15	20,2	–
15	15	0/-8	+3/-11	26	0/-9	+6/-15	9	12	18,7	24,2	24
17	17	0/-8	+3/-11	30	0/-11	+8/-19	10	14	21,2	28,2	28
20	20	0/-10	+3/-13	35	0/-11	+8/-19	12	16	24,9	33,2	33

Dimensions cont., loads and clearance

Nominal bore code	Dimensions		R +0,1/0	r	r ₁	α ⁽⁴⁾	Mass ≈	Static limit loads ⁽³⁾		Axial clearance		Radial clearance Max	
	P 0/-0,2 Code R	Code PR						Radial C _s	Axial C _a ⁽²⁾	Reduced	Standard	Reduced	Standard
–	mm	mm	mm	mm	mm	°	g	kN	mm	μm	μm	μm	μm
4	–	–	–	0,4/0,7	0,3/0,6	16	3	7,2	0,45	5/35	35/75	10	20
5	–	–	–	0,4/0,7	0,3/0,6	13	4	12,6	0,8	5/35	35/75	10	20
6	–	–	–	0,4/0,7	0,3/0,6	13	4	16	1	5/35	35/75	10	20
8	0,7	–	0,2	0,5/0,8	0,3/0,6	15	8	21	1,8	5/35	35/75	10	20
10	0,7	–	0,2	0,5/0,8	0,5/0,8	15	12	31	2,5	5/35	35/75	10	20
12	0,7	–	0,2	0,6/1	0,5/0,8	11	17	40,5	3,5	5/35	35/75	10	20
15	0,7	0,9	0,2	0,6/1	0,5/0,8	9	32	70	5,3	5/35	35/75	10	20
17	0,7	0,9	0,2	0,9/1,3	0,5/0,8	10	49	91,4	6,7	5/40	40/80	12	25
20	0,7	0,9	0,2	0,9/1,3	0,5/0,8	9	65	130	9,8	5/40	40/80	12	25

²⁾ These values can be limited by the unstaking load (contact SKF for more information)

³⁾ Loads are valid for the steel/steel spherical plain bearings without lubrication groove. For other bearings, refer to page 134

⁴⁾ Values are given for non protected bearings. For sealed and shielded bearings, refer to page 140



Designation system

Examples: ZWQMAS20RXTT-2CP6R10
QMAC15PPCP109

Surface treatment of outer ring

No code Not plated
Z¹⁾ Cadmium plated external dimensions
SZ¹⁾ Zinc-nickel plated external dimensions

Material code	Inner ring material	Outer ring material
W	Corrosion-resistant steel	Corrosion-resistant steel
Q¹⁾	Bronze beryllium	Corrosion-resistant steel
WQ¹⁾	Corrosion-resistant steel	Bronze aluminium

Basic designation

Lubrication grooves

No code Without lubrication groove
S³⁾ Lubrication by inner ring
C³⁾ 6) Lubrication by outer ring
Y³⁾ Lubrication by inner and outer ring

Bore code

Chamfer and groove

No code Chamfered outer ring
R or PR²⁾ Grooved outer ring

Clearances

No code Standard clearances
X Reduced clearances

Shield and seal

No code No shield and seal
TT^{1) 7)} Sealed
PP^{1) 7)} Shielded

Lubricant

No code Grease G354
-2 Grease G395

Surface treatment of inner ring

No code Not plated
CP6⁵⁾ Chromium plated sphere
CP109⁵⁾ XCR plating on sphere (chromium 6 free replacement to chromium plating)
CP55⁴⁾ Passivated corrosion-resistant steel inner ring

Oversize

No code Standard outer diameter size
R10¹⁾ 0,1 mm oversized outer diameter
R20¹⁾ 0,2 mm oversized outer diameter

¹⁾ SKF option

²⁾ SKF option for bore code ≥ 8 and ≤ 10

³⁾ SKF option for bore code ≤ 12

⁴⁾ Available only for inner ring in corrosion-resistant steel material

⁵⁾ SKF option, available only for inner ring in corrosion-resistant steel material

⁶⁾ In the outer ring sphere, central lubrication groove only for $d \leq 6$

⁷⁾ Only available for $d \geq 6$

2.5 Metal-to-metal swaged light (metric dimensions)

MA bore code 25 to 70

Technical specification EN 2337
Product standards EN 2335
Surface treatment For products with inner and outer rings in corrosion-resistant steel, one of the spherical surfaces is treated with molybdenum disulfide

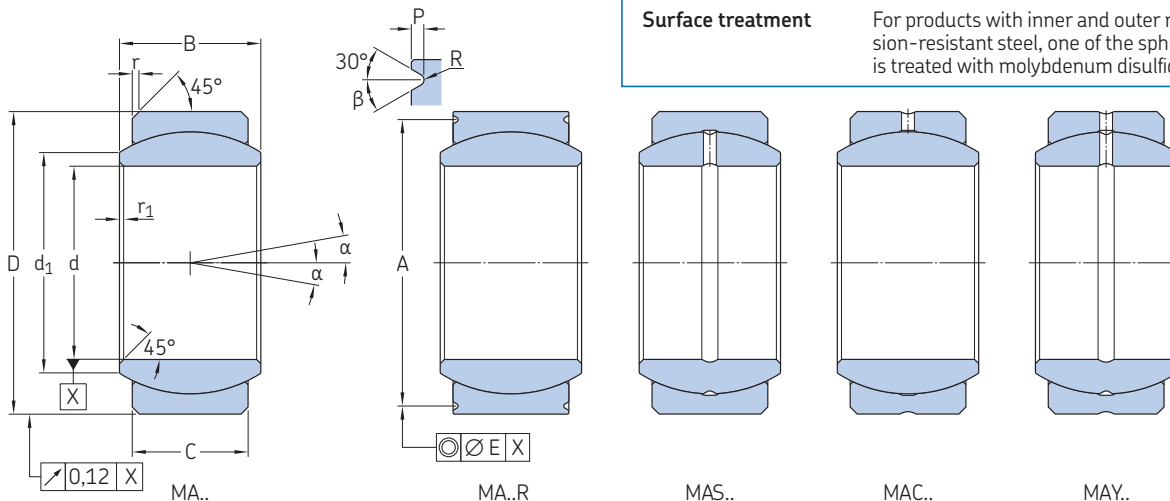

β	E
°	mm
30	0,12

Dimensions

Nominal bore code	Dimensions										
	d	Δd_{mp}	Δd_s	D	ΔD_{mp}	ΔD_s	C $\pm 0,1$	B 0/-0,06	$d_1 \approx$	A +0,1/0 Code R	Code PR
–	mm	μm		mm	μm		mm				
25	25	0/-10	+3/-13	42	0/-11	+8/-19	16	20	30	39,4	38,8
30	30	0/-10	+3/-13	47	0/-11	+8/-19	18	22	34,3	44,4	43,8
35	35	0/-12	+3/-15	55	0/-13	+10/-23	20	25	40,5	51,8	–
40	40	0/-12	+3/-15	62	0/-13	+10/-23	22	28	45	58,8	–
45	45	0/-12	+3/-15	68	0/-13	+10/-23	25	32	51,3	64,8	–
50	50	0/-12	+3/-15	75	0/-13	+10/-23	28	35	58,2	71,8	–
60	60	0/-15	+4/-19	90	0/-15	+13/-28	36	44	66,8	86,8	–
70 ¹⁾	70	0/-15	+4/-19	105	0/-15	+13/-28	40	49	77,8	101,8	–

Dimensions cont., loads and clearance

Nominal bore code	Dimensions							Mass =	Static limit loads ³⁾		Axial clearance		Radial clearance Max	
	P 0/-0,2 Code R	R +0,1/0 Code PR	r	r_1	$\alpha^4)$	Radial C_s	Axial $C_a^2)$		Reduced	Standard	Reduced	Standard		
–	mm							g	kN	μm				
25	0,9	1,4	0,3	0,9/1,3	0,5/0,8	7	115	216,7	18	5/50	50/100	15	30	
30	0,9	1,4	0,3	0,9/1,3	0,5/0,8	6	160	277,5	25	5/50	50/100	15	30	
35	1,4	–	0,3	0,9/1,3	0,6/1	7	229	359,9	31	5/50	50/100	15	30	
40	1,4	–	0,3	1,4/1,8	0,6/1	7	315	428,8	38	5/50	50/100	15	30	
45	1,4	–	0,3	1,4/1,8	0,6/1	7	460	558,4	50	5/60	60/120	20	35	
50	1,4	–	0,3	1,4/1,8	1,2/1,7	7	560	760,1	64	5/60	60/120	20	35	
60	1,4	–	0,3	1,4/1,8	1,2/1,7	6	1 100	1 056	104	5/60	60/120	20	35	
70 ¹⁾	1,4	–	0,3	1,4/1,8	1,2/1,7	6	1 540	1 361,6	197,3	5/60	60/120	20	35	

1) SKF option

2) These values can be limited by the unstaking load (contact SKF for more information)

3) Loads are valid for the steel/steel spherical plain bearings without lubrication groove. For other bearings, refer to page 134

4) Values are given for non protected bearings. For sealed and shielded bearings, refer to page 140



Designation system

Examples: ZWQMAS20RXTT-2CP6R10
QMAC15PPCP109

Surface treatment of outer ring

No code Not plated
Z¹⁾ Cadmium plated external dimensions
SZ¹⁾ Zinc-nickel plated external dimensions

Material code	Inner ring material	Outer ring material
W	Corrosion-resistant steel	Corrosion-resistant steel
Q¹⁾	Bronze beryllium	Corrosion-resistant steel
WQ¹⁾	Corrosion-resistant steel	Bronze aluminium

Basic designation

Lubrication grooves

No code Without lubrication groove
S³⁾ Lubrication by inner ring
C³⁾ 6) Lubrication by outer ring
Y³⁾ Lubrication by inner and outer ring

Bore code

Chamfer and groove

No code Chamfered outer ring
R or PR²⁾ Grooved outer ring

Clearances

No code Standard clearances
X Reduced clearances

Shield and seal

No code No shield and seal
TT^{1) 7)} Sealed
PP^{1) 7)} Shielded

Lubricant

No code Grease G354
-2 Grease G395

Surface treatment of inner ring

No code Not plated
CP6⁵⁾ Chromium plated sphere
CP109⁵⁾ XCR plating on sphere (chromium 6 free replacement to chromium plating)
CP55⁴⁾ Passivated corrosion-resistant steel inner ring

Oversize

No code Standard outer diameter size
R10¹⁾ 0,1 mm oversized outer diameter
R20¹⁾ 0,2 mm oversized outer diameter

- 1) SKF option
 2) SKF option for bore code ≥ 8 and ≤ 10
 3) SKF option for bore code ≤ 12
 4) Available only for inner ring in corrosion-resistant steel material
 5) SKF option, available only for inner ring in corrosion-resistant steel material
 6) In the outer ring sphere, central lubrication groove only for $d \leq 6$
 7) Only available for $d \geq 6$

2.6 Metal-to-metal swaged narrow (metric dimensions)

ME bore code 5 to 20

Technical specification –

Product standards –

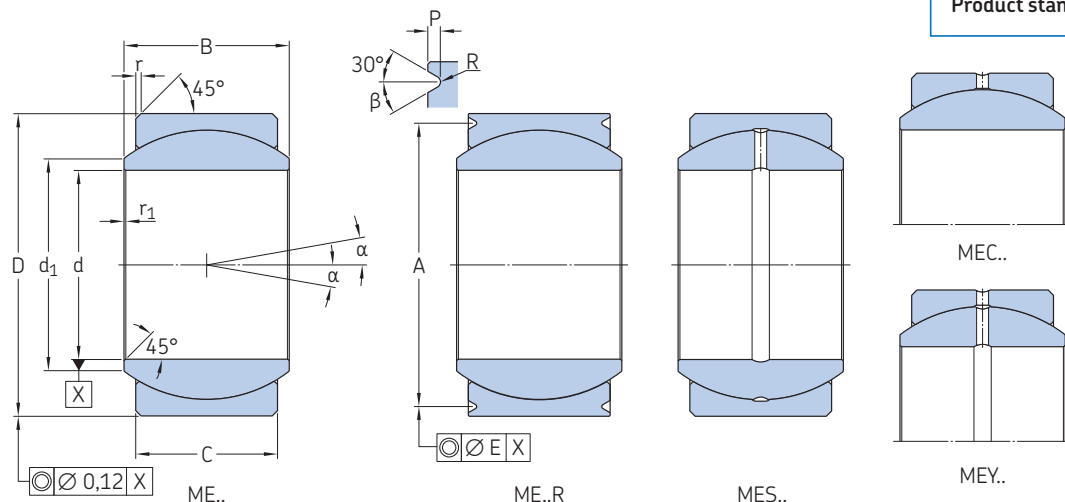

d	β	E
mm	°	mm
≤ 8	20	0,08
≥ 10	30	0,12

Dimensions

Nominal bore code	Dimensions					
	d	Δdmp	D	ΔDmp	C ±0,1	B 0/-0,06
–	mm	μm	mm	μm	mm	
5	5	0/-8	14	0/-8	5,5	7
6	6	0/-8	16	0/-8	6,5	9
8	8	0/-8	18	0/-8	7	10
10	10	0/-8	21	0/-9	8	10,5
12	12	0/-8	25	0/-9	10	13
15	15	0/-8	29	0/-9	12	15
17	17	0/-8	31	0/-9	13,5	16
20	20	0/-10	40	0/-11	18	22

Dimensions cont., loads and clearance

Nominal bore code	Dimensions							Mass ≈	Static limit loads ²⁾		Axial clearance	
	d ₁ ≈	A +0,1/0	P 0/-0,2	R +0,1/0	r	r ₁ +0,3/0	α ³⁾		Radial C _s	Axial C _a ¹⁾	Reduced	Standard
–	mm						°	g	kN		μm	
5	8,6	12,2	0,7	0,2	0,5/0,8	0,1	9	7	20,5	1,9	5/35	35/75
6	9	14,2	0,7	0,2	0,5/0,8	0,1	14	9	29,2	3,5	5/35	35/75
8	10,2	16,2	0,7	0,2	0,5/0,8	0,1	15	12	37	3,9	5/35	35/75
10	11,9	18,4	0,9	0,3	0,5/0,8	0,1	11	20	47,2	6,5	5/35	35/75
12	15	22,4	0,9	0,3	0,5/0,8	0,1	10	32	78,1	11,7	5/35	35/75
15	20,5	26,4	0,9	0,3	0,5/0,8	0,1	8	50	121,9	18	5/35	35/75
17	21,7	28,4	0,9	0,3	0,5/0,8	0,1	7	59	148,3	24,3	5/40	40/80
20	27,1	36,8	1,4	0,3	0,6/1	0,1	8	135	268,6	45,5	5/40	40/80

¹⁾ These values can be limited by the unstaking load (contact SKF for more information)

²⁾ Loads are valid for the steel/steel spherical plain bearings without lubrication groove. For other bearings, refer to page 134

³⁾ Values are given for non protected bearings. For sealed and shielded bearings, refer to page 140



Designation system

Examples: ZWQMES22RXTT-2CP6R10
QMEC30PPCP109

Surface treatment of outer ring

No code Not plated
Z Cadmium plated external dimensions
SZ Zinc-nickel plated external dimensions

Material code

Material code	Inner ring material	Outer ring material
W	Corrosion-resistant steel	Corrosion-resistant steel
Q	Bronze beryllium	Corrosion-resistant steel
WQ	Corrosion-resistant steel	Bronze aluminium

Basic designation

Lubrication grooves

No code Without lubrication groove
S Lubrication by inner ring
C³⁾ Lubrication by outer ring
Y Lubrication by inner and outer ring

Bore code

Chamfer and groove

No code Chamfered outer ring
R Grooved outer ring

Axial clearance

No code Standard axial clearance
X Reduced axial clearance

Shield and seal

No code No shield and seal
TT⁴⁾ Sealed
PP⁴⁾ Shielded

Lubricant

No code Grease G354
-2 Grease G395

Surface treatment of inner ring

No code Not plated
CP6²⁾ Chromium plated sphere
CP109²⁾ XCR plating on sphere (chromium 6 free replacement to chromium plating)
CP55²⁾ Passivated corrosion-resistant steel inner ring

Oversize

No code Standard outer diameter size
R10 0,1 mm oversized outer diameter
R20 0,2 mm oversized outer diameter

²⁾ Available only for inner ring in corrosion-resistant steel material

³⁾ In the outer ring sphere, central lubrication groove only for $d \leq 6$

⁴⁾ Only available for $d \geq 6$

2.6 Metal-to-metal swaged narrow (metric dimensions)

ME bore code 22 to 50

Technical specification –
Product standards –

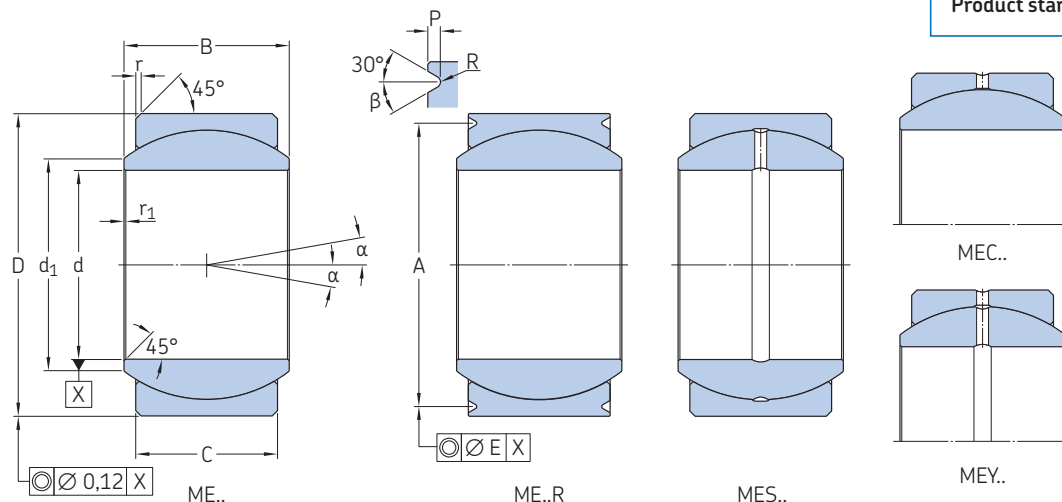

d	β	E
mm	°	mm
≤ 8	20	0,08
≥ 10	30	0,12

Dimensions

Nominal bore code	Dimensions					
	d	Δd_{mp}	D	ΔD_{mp}	C ±0,1	B 0/-0,06
–	mm	μm	mm	μm	mm	–
22	22	0/-10	40	0/-11	18	22
25	25	0/-10	45	0/-11	20	25
30	30	0/-10	51	0/-13	24	28
35	35	0/-12	57	0/-13	26	31
40	40	0/-12	64	0/-13	29	34
45	45	0/-12	72	0/-13	32	37
50	50	0/-12	80	0/-15	34	41

Dimensions cont., loads and clearance

Nominal bore code	Dimensions							Mass ≈	Static limit loads ²⁾		Axial clearance	
	d ₁ ≈	A +0,1/0	P 0/-0,2	R +0,1/0	r	r ₁ +0,3/0	α ³⁾		Radial C _s	Axial C _a ¹⁾	Reduced	Standard
–	mm	–	–	–	–	–	°	g	kN	–	μm	–
22	27,1	36,8	1,4	0,3	0,6/1	0,1	8	126	268,6	45,5	5/40	40/80
25	29,6	41,8	1,4	0,3	0,6/1	0,1	8	185	324,7	55,9	5/50	50/100
30	35,5	47,8	1,4	0,3	0,6/1	0,1	6	300	433,4	77,8	5/50	50/100
35	41,7	53,8	1,4	0,3	0,8/1,2	0,1	7	340	543,4	92,2	5/50	50/100
40	47	60,8	1,4	0,3	0,8/1,2	0,1	6	460	680,9	113,4	5/50	50/100
45	52,2	68,8	1,4	0,3	0,8/1,2	0,1	5	630	833,9	135,9	5/60	60/120
50	59,2	76,8	1,4	0,3	0,8/1,2	0,1	7	870	981,4	154,2	5/60	60/120

¹⁾ These values can be limited by the unstaking load (contact SKF for more information)

²⁾ Loads are valid for the steel/steel spherical plain bearings without lubrication groove. For other bearings, refer to page 134

³⁾ Values are given for non protected bearings. For sealed and shielded bearings, refer to page 140



Designation system

Examples: ZWQMES22RXTT-2CP6R10
QMEC30PPCP109

Surface treatment of outer ring

No code Not plated
Z Cadmium plated external dimensions
SZ Zinc-nickel plated external dimensions

Material code

Material code	Inner ring material	Outer ring material
W	Corrosion-resistant steel	Corrosion-resistant steel
Q	Bronze beryllium	Corrosion-resistant steel
WQ	Corrosion-resistant steel	Bronze aluminium

Basic designation

Lubrication grooves

No code Without lubrication groove
S Lubrication by inner ring
C³⁾ Lubrication by outer ring
Y Lubrication by inner and outer ring

Bore code

Chamfer and groove

No code Chamfered outer ring
R Grooved outer ring

Axial clearance

No code Standard axial clearance
X Reduced axial clearance

Shield and seal

No code No shield and seal
TT⁴⁾ Sealed
PP⁴⁾ Shielded

Lubricant

No code Grease G354
-2 Grease G395

Surface treatment of inner ring

No code Not plated
CP6²⁾ Chromium plated sphere
CP109²⁾ XCR plating on sphere (chromium 6 free replacement to chromium plating)
CP55²⁾ Passivated corrosion-resistant steel inner ring

Oversize

No code Standard outer diameter size
R10 0,1 mm oversized outer diameter
R20 0,2 mm oversized outer diameter

²⁾ Available only for inner ring in corrosion-resistant steel material

³⁾ In the outer ring sphere, central lubrication groove only for $d \leq 6$

⁴⁾ Only available for $d \geq 6$

2.7 Metal-to-metal swaged wide (metric dimensions)

ML bore code 5 to 20

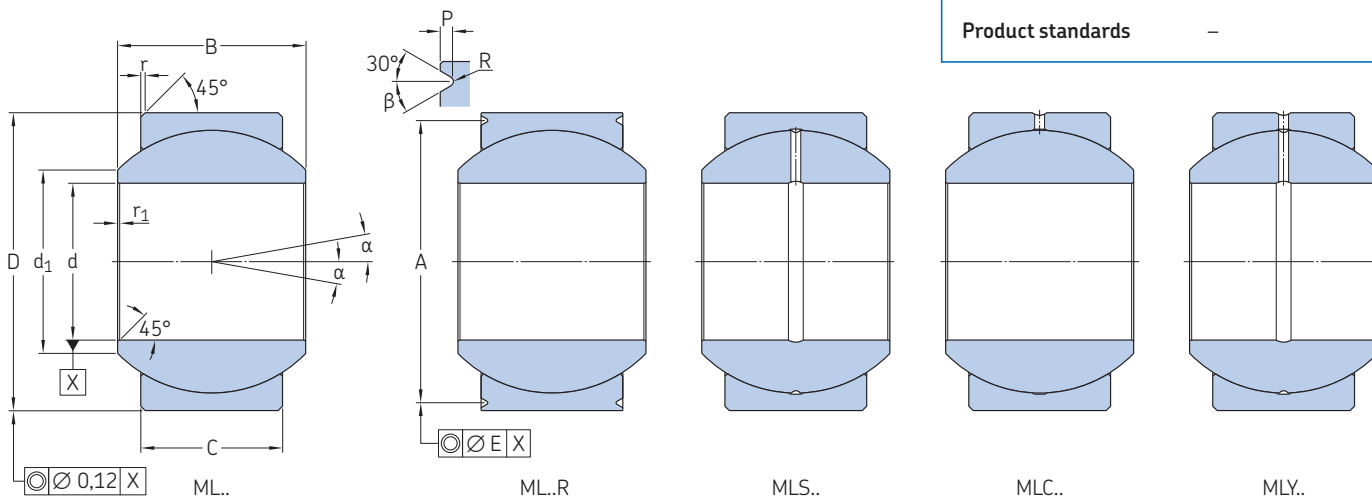

d	β	E
mm	°	mm
≤ 6	20	0,08
= 8	30	0,08
≥ 10	30	0,12

Dimensions

Nominal bore code	Dimensions					
	d	Δd_{mp}	D	ΔD_{mp}	C $\pm 0,1$	B 0/-0,06
-	mm	μm	mm	μm	mm	
5	5	0/-8	16	0/-8	8,5	11
6	6	0/-8	16	0/-8	8,5	11
8	8	0/-8	18	0/-8	8	11
10	10	0/-8	21	0/-9	10	12,5
12	12	0/-8	26	0/-9	13	16
15	15	0/-8	29	0/-9	13,5	17
17	17	0/-8	30	0/-9	14,5	18
20	20	0/-10	35	0/-11	16	20

Dimensions cont., loads and clearance

Nominal bore code	Dimensions							Mass ≈	Static limit loads ²⁾		Axial clearance	
	d ₁ ≈	A +0,1/0	P 0/-0,2	R +0,1/0	r	r ₁ +0,3/0	$\alpha^{3)}$		Radial C _s	Axial C _a ¹⁾	Reduced	Standard
-	mm						°	g	kN		μm	
5	7,7	14,2	0,7	0,2	0,5/0,8	0,1	15	16	42,6	7,2	5/35	35/75
6	7,7	14,2	0,7	0,2	0,5/0,8	0,1	15	16	42,6	7,2	5/35	35/75
8	10,3	16,2	0,7	0,2	0,5/0,8	0,1	14	17	45,7	6,4	5/35	35/75
10	12,2	18,4	0,9	0,3	0,5/0,8	0,1	10	27	68,7	11,7	5/35	35/75
12	15,5	23,4	0,9	0,3	0,5/0,8	0,1	10	49	116,4	21,5	5/35	35/75
15	18,9	26,4	0,9	0,3	0,5/0,8	0,1	9	62	139	24,1	5/35	35/75
17	20,1	27,4	0,9	0,3	0,5/0,8	0,1	9	69	159,1	29	5/40	40/80
20	23,5	31,8	1,4	0,3	0,5/0,8	0,1	8	104	207,5	36	5/40	40/80

¹⁾ These values can be limited by the unstaking load (contact SKF for more information)

²⁾ Loads are valid for the steel/steel spherical plain bearings without lubrication groove. For other bearings, refer to page 134

³⁾ Values are given for non protected bearings. For sealed and shielded bearings, refer to page 140



Designation system

Examples: ZWQMLS20RXTT-2CP6R10 Z WQ ML S 20 R X TT -2 CP6 R10
 QMLC30PPCP109

Surface treatment of outer ring

No code Not plated
Z Cadmium plated external dimensions
SZ Zinc-nickel plated external dimensions

Material code

	Inner ring material	Outer ring material
W	Corrosion-resistant steel	Corrosion-resistant steel
Q	Bronze beryllium	Corrosion-resistant steel
WQ	Corrosion-resistant steel	Bronze aluminium

Basic designation

Lubrication grooves

No code Without lubrication groove
S Lubrication by inner ring
C³⁾ Lubrication by outer ring
Y Lubrication by inner and outer ring

Bore code

Chamfer and groove

No code Chamfered outer ring
R Grooved outer ring

Axial clearance

No code Standard axial clearance
X Reduced axial clearance

Shield and seal

No code No shield and seal
TT⁴⁾ Sealed
PP⁴⁾ Shielded

Lubricant

No code Grease G354
-2 Grease G395

Surface treatment of inner ring

No code Not plated
CP6²⁾ Chromium plated sphere
CP109²⁾ XCR plating on sphere (chromium 6 free replacement to chromium plating)
CP55²⁾ Passivated corrosion-resistant steel inner ring

Oversize

No code Standard outer diameter size
R10 0,1 mm oversized outer diameter
R20 0,2 mm oversized outer diameter

²⁾ Available only for inner ring in corrosion-resistant steel material

³⁾ In the outer ring sphere, central lubrication groove only for $d \leq 6$

⁴⁾ Only available for $d \geq 6$

2.7 Metal-to-metal swaged wide (metric dimensions)

ML bore code 25 to 60

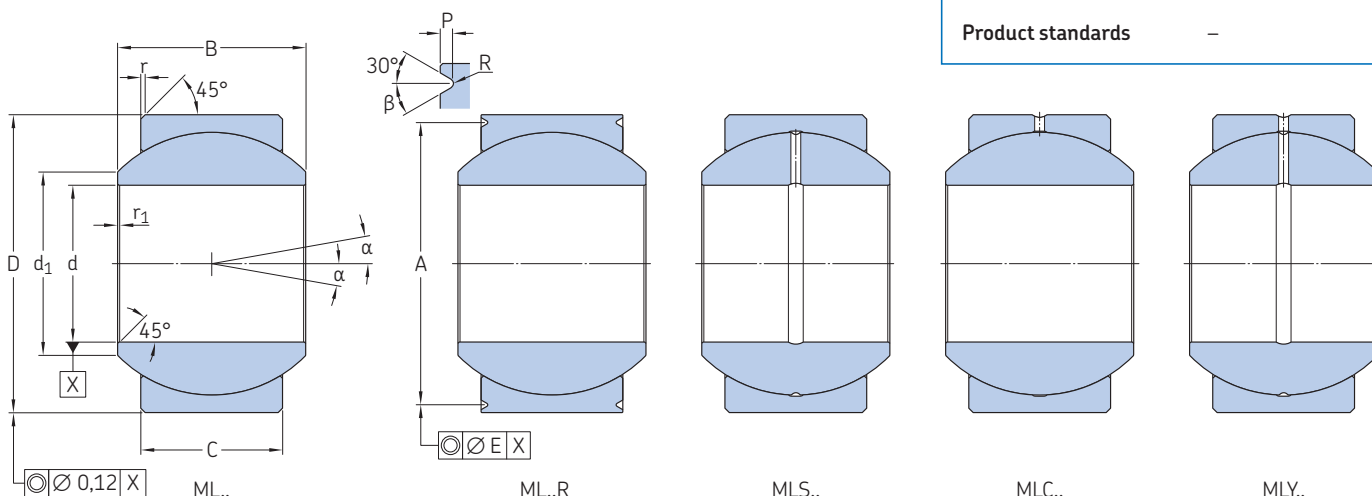

d	β	E
mm	°	mm
≤ 6	20	0,08
= 8	30	0,08
≥ 10	30	0,12

Dimensions

Nominal bore code	Dimensions					
	d	Δdmp	D	ΔDmp	C ±0,1	B 0/-0,06
–	mm	μm	mm	μm	mm	
25	25	0/-10	54	0/-13	26	32
30	30	0/-10	60	0/-13	28	34
35	35	0/-12	65	0/-13	29	36
40	40	0/-12	68	0/-13	31	38
45	45	0/-12	76	0/-13	33	41
50	50	0/-12	82	0/-15	35	44
55	55	0/-12	96	0/-15	40	52
60	60	0/-12	105	0/-15	48	60

Dimensions cont., loads and clearance

Nominal bore code	Dimensions							Mass ≈	Static limit loads ²⁾		Axial clearance	
	d ₁ ≈	A +0,1/0	P 0/-0,2	R +0,1/0	r	r ₁ +0,3/0	α ³⁾		Radial C _s	Axial C _a ¹⁾	Reduced	Standard
–	mm						°	g	kN		μm	
25	35,3	50,8	1,4	0,3	0,6/1	0,1	9	445	496,6	93,2	5/50	50/100
30	40,9	56,8	1,4	0,3	0,8/1,2	0,1	8	480	587,5	109,6	5/50	50/100
35	45,5	61,8	1,4	0,3	0,8/1,2	0,1	8	565	666,0	117,6	5/50	50/100
40	47	64,8	1,4	0,3	0,8/1,2	0,1	8	600	745,6	136,6	5/50	50/100
45	54,1	72,8	1,4	0,3	0,8/1,2	0,1	8	800	895,9	155,6	5/60	60/120
50	60,3	78,8	1,4	0,3	0,8/1,2	0,1	8	970	1 024,7	176,2	5/60	60/120
55	63,4	92,8	1,5	0,3	0,8/1,2	0,1	10	1 580	1 298,7	221,2	5/60	60/120
60	69,7	101,8	1,5	0,3	0,8/1,2	0,1	9	2 250	1 681,8	243,7	5/60	60/120

¹⁾ These values can be limited by the unstaking load (contact SKF for more information)

²⁾ Loads are valid for the steel/steel spherical plain bearings without lubrication groove. For other bearings, refer to page 134

³⁾ Values are given for non protected bearings. For sealed and shielded bearings, refer to page 140



Designation system

Examples: ZWQMLS20RXTT-2CP6R10 Z WQ ML S 20 R X TT -2 CP6 R10
 QMLC30PPCP109

Surface treatment of outer ring

No code Not plated
Z Cadmium plated external dimensions
SZ Zinc-nickel plated external dimensions

Material code **Inner ring material** **Outer ring material**
W Corrosion-resistant steel Corrosion-resistant steel
Q Bronze beryllium Corrosion-resistant steel
WQ Corrosion-resistant steel Bronze aluminium

Basic designation

Lubrication grooves

No code Without lubrication groove
S Lubrication by inner ring
C³⁾ Lubrication by outer ring
Y Lubrication by inner and outer ring

Bore code

Chamfer and groove

No code Chamfered outer ring
R Grooved outer ring

Axial clearance

No code Standard axial clearance
X Reduced axial clearance

Shield and seal

No code No shield and seal
TT⁴⁾ Sealed
PP⁴⁾ Shielded

Lubricant

No code Grease G354
-2 Grease G395

Surface treatment of inner ring

No code Not plated
CP6²⁾ Chromium plated sphere
CP109²⁾ XCR plating on sphere (chromium 6 free replacement to chromium plating)
CP55²⁾ Passivated corrosion-resistant steel inner ring

Oversize

No code Standard outer diameter size
R10 0,1 mm oversized outer diameter
R20 0,2 mm oversized outer diameter

²⁾ Available only for inner ring in corrosion-resistant steel material

³⁾ In the outer ring sphere, central lubrication groove only for $d \leq 6$

⁴⁾ Only available for $d \geq 6$

2.8 Metal-to-metal swaged high misalignment (metric dimensions)

MT

Technical specification –
Product standards –

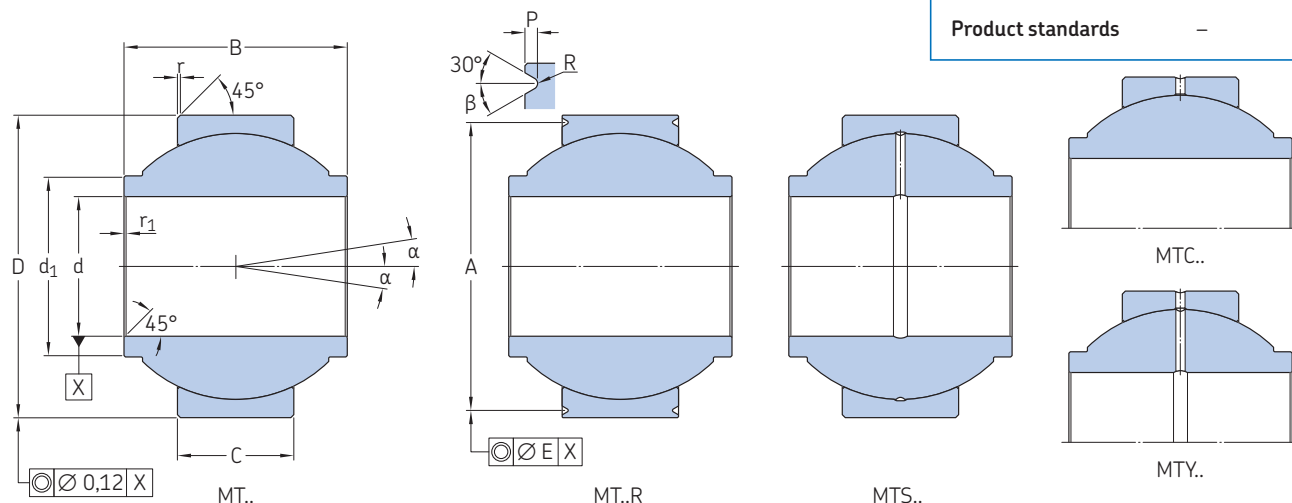

d	β	E
mm	°	mm
≤ 6	20	0,08
≥ 8	30	0,12

Dimensions

Nominal bore code	Dimensions			D	ΔDmp	C ±0,1	B 0/-0,06
	d	Δdmp					
–	mm	μm	mm	μm	mm		
5	5	0/-8	14	0/-8	5	12,5	
6	6	0/-8	19	0/-8	6	15	
8	8	0/-8	25	0/-9	9	21	
10	10	0/-8	25	0/-9	9	21	
12	12	0/-8	30	0/-9	10	24	
17	17	0/-8	36	0/-11	14	30	
20	20	0/-10	40	0/-11	16	33	
22	22	0/-10	45	0/-11	16	36	
25	25	0/-10	54	0/-13	21	48	
30	30	0/-10	65	0/-13	25	48	

Dimensions cont., loads and clearance

Nominal bore code	Dimensions							Mass ≈	Static limit loads ²⁾		Axial clearance	
	d ₁ ≈	A +0,15/0	P 0/-0,2	R +0,1/0	r +0,3/0	r ₁ +0,3/0	α ³⁾		Radial C _s	Axial C _a ¹⁾	Reduced	Standard
–	mm						°	g	kN		μm	
5	7,8	12,2	0,7	0,2	0,5	0,1	15	8	16,5	0,7	5/35	35/75
6	9,6	17,2	0,7	0,2	0,5	0,1	24	17	30,5	1,3	5/35	35/75
8	13,3	22,4	0,9	0,3	0,5	0,1	20	39	70,4	8,4	5/35	35/75
10	13,3	22,4	0,9	0,3	0,5	0,1	20	34	70,4	8,4	5/35	35/75
12	17,7	27,4	0,9	0,3	0,5	0,1	20	65	95,8	10,3	5/35	35/75
17	21,8	33,4	0,9	0,3	0,5	0,1	20	110	174,6	25,8	5/40	40/80
20	24	36,8	1,4	0,3	0,5	0,1	19	142	234,4	33,3	5/40	40/80
22	28,3	41,8	1,4	0,3	0,5	0,1	19	194	266,3	33,3	5/40	40/80
25	32,2	50,8	1,4	0,3	0,5	0,1	21	401	391,8	55,9	5/50	50/100
30	38,8	61,8	1,4	0,3	0,5	0,1	21	600	583,7	75,9	5/50	50/100

¹⁾ These values can be limited by the unstaking load (contact SKF for more information)

²⁾ Loads are valid for the steel/steel spherical plain bearings without lubrication groove. For other bearings, refer to page 134

³⁾ Values are given for non protected bearings. For sealed and shielded bearings, refer to page 140



Designation system

Examples: ZWQMTS20RXTT-2CP6R10
QMT30PPCP109

Surface treatment of outer ring

No code Not plated
Z Cadmium plated external dimensions
SZ Zinc-nickel plated external dimensions

Material code

Material code	Inner ring material	Outer ring material
W	Corrosion-resistant steel	Corrosion-resistant steel
Q	Bronze beryllium	Corrosion-resistant steel
WQ	Corrosion-resistant steel	Bronze aluminium

Basic designation

Lubrication grooves

No code Without lubrication groove
S Lubrication by inner ring
C³⁾ Lubrication by outer ring
Y Lubrication by inner and outer ring

Bore code

Chamfer and groove

No code Chamfered outer ring
R Grooved outer ring

Axial clearance

No code Standard axial clearance
X Reduced axial clearance

Shield and seal

No code No shield and seal
TT⁴⁾ Sealed
PP⁴⁾ Shielded

Lubricant

No code Grease G354
-2 Grease G395

Surface treatment of inner ring

No code Not plated
CP6²⁾ Chromium plated sphere
CP109²⁾ XCR plating on sphere (chromium 6 free replacement to chromium plating)
CP55²⁾ Passivated corrosion-resistant steel inner ring

Oversize

No code Standard outer diameter size
R10 0,1 mm oversized outer diameter
R20 0,2 mm oversized outer diameter

²⁾ Available only for inner ring in corrosion-resistant steel material

³⁾ In the outer ring sphere, central lubrication groove only for $d \leq 6$

⁴⁾ Only available for $d \geq 6$

2.9 Metal-to-metal split (metric dimensions)

2PL..

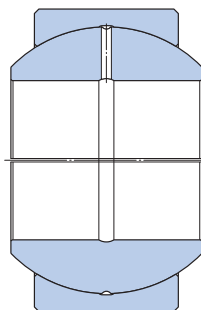
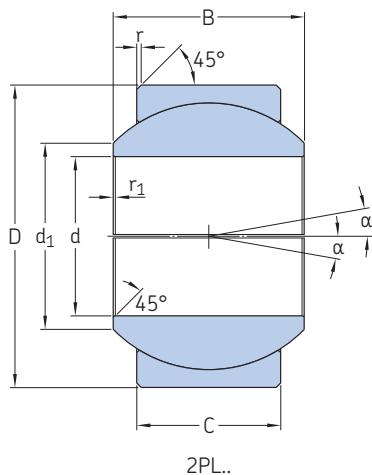

2PLS..

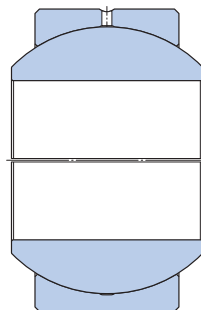

2PLC..

Technical specification -

Product standards -

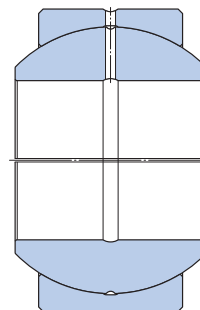

2PLY..

Dimensions

Nominal bore code	Dimensions d	Δd_{mp}	D	ΔD_{mp}	C ± 1	B 0/-0,06
-	mm	μm	mm	μm	mm	
10	10	0/-7	21	0/-8	10	12,5
12	12	0/-8	26	0/-8	13	16
15	15	0/-8	29	0/-8	13,5	17
17	17	0/-8	30	0/-8	14,5	18
20	20	0/-9	35	0/-9	16	20
25	25	0/-9	54	0/-11	26	32
30	30	0/-9	60	0/-11	28	34
35	35	0/-11	65	0/-11	29	36
40	40	0/-11	68	0/-11	31	38
45	45	0/-11	76	0/-11	33	41
50	50	0/-11	82	0/-13	35	44
55	55	0/-12	96	0/-13	40	52
60	60	0/-12	105	0/-13	48	60

Dimensions cont., loads and clearance

Nominal bore code	Dimensions				Mass \approx	Static limit loads ¹⁾		Radial clearance
	$d_1 \approx$	r +0,3/0	r_1 +0,3/0	$\alpha^{2)}$		Radial C_s	Axial C_a	
-	mm			°	g	kN		μm
10	12,2	0,5	0,1	10	27	94,3	21	10/20
12	15,5	0,5	0,1	10	49	160	37,3	10/20
15	18,9	0,5	0,1	9	62	190,5	40,5	10/30
17	20,1	0,5	0,1	9	69	218,5	47,2	10/30
20	23,5	0,5	0,1	8	104	278,1	58,3	10/30
25	35,3	0,7	0,1	9	445	702,9	156,8	10/30
30	40,9	0,9	0,1	8	480	861,2	188,9	10/30
35	45,5	0,9	0,1	8	565	974,6	203,2	10/40
40	47	0,9	0,1	8	600	1 080,3	230,2	10/40
45	54,1	0,9	0,1	8	800	1 286,8	258,8	10/40
50	60,3	0,9	0,1	8	970	1 504,2	292,6	10/40
55	63,4	0,9	0,1	10	1 580	1 991,8	386,2	10/40
60	69,7	0,9	0,1	9	2 250	2 572,3	562,8	10/40

¹⁾ Loads are valid for the steel/steel spherical plain bearings without lubrication groove. For other bearings, refer to page 134

²⁾ Values are given for non protected bearings. For sealed and shielded bearings, refer to page 140



Designation system

Examples:	ZW2PLS20TT-2CP6R10	Z	W	2PL	S	20	TT	-2	CP6	R10
	Q2PLC30PPCP109									
Surface treatment of outer ring										
No code	Not plated									
Z	Cadmium plated external dimensions									
SZ	Zinc-nickel plated external dimensions									
Material code	Inner ring material									
W	Corrosion-resistant steel									
Q	Bronze beryllium									
WQ	Corrosion-resistant steel									
	Outer ring material									
	Corrosion-resistant steel									
	Corrosion-resistant steel									
	Bronze aluminium									
Basic designation										
Lubrication grooves										
No code	Without lubrication groove									
S	Lubrication by inner ring									
C	Lubrication by outer ring									
Y	Lubrication by inner and outer ring									
Bore code										
Shield and seal										
No code	No shield and seal									
TT	Sealed									
PP	Shielded									
Lubricant										
No code	Grease G354									
-2	Grease G395									
Surface treatment of inner ring										
No code	Not plated									
CP6¹⁾	Chromium plated									
CP109¹⁾	XCR plating on sphere (chromium 6 free replacement to chromium plating)									
CP55¹⁾	Passivated corrosion-resistant steel inner ring									
Oversize										
No code	Standard outer diameter size									
R10	0,1 mm oversized outer diameter									
R20	0,2 mm oversized outer diameter									

¹⁾ Available only for inner ring in corrosion-resistant steel material

2.10 Metal-to-metal loader slot wide (inch dimensions)

GT..

Technical specification –

Product standards –

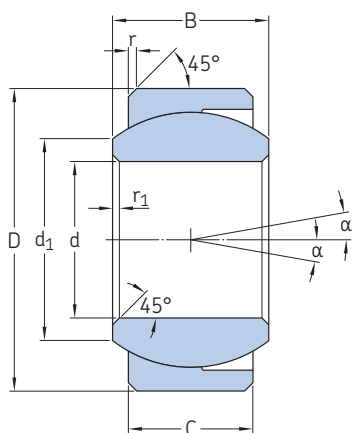

GT..

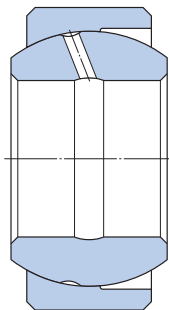

GTS..

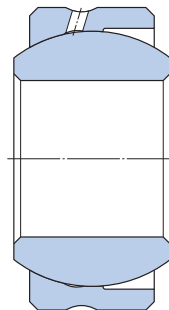

GTC..

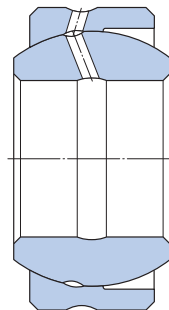

GTY..

2.10



Dimensions

Nominal bore code	Dash number multiples of 1/16 inch	Dimensions							
		d	D	C	B	d ₁	r ₁	r	α ¹⁾
		0/-0.0005	0/-0.0005	±0.005	0/-0.002	d ₁ ≈	±0.005	+0.010/0	
		0/-0,0127	0/-0,0127	±0,127	0/-0,051		±0,127	+0.254/0	
		in/mm							
		°							
12,7	08	0.5000 12,700	1.0000 25,400	0.390 9,906	0.500 12,700	0.600 15,240	0.010 0,254	0.020 0,508	8
14,29	09	0.5625 14,288	1.0937 27,780	0.437 11,100	0.562 14,275	0.670 17,018	0.010 0,254	0.020 0,508	9
15,87	10	0.6250 15,875	1.1875 30,163	0.500 12,700	0.625 15,875	0.739 18,771	0.010 0,254	0.020 0,508	8
19,05	12	0.7500 19,050	1.4375 36,513	0.593 15,062	0.750 19,050	0.920 23,368	0.010 0,254	0.030 0,762	8
22,22	14	0.8750 22,225	1.5625 39,688	0.703 17,856	0.875 22,225	0.980 24,892	0.010 0,254	0.030 0,762	8
25,4	16	1.0000 25,400	1.7500 44,450	0.797 20,244	1.000 25,400	1.118 28,397	0.010 0,254	0.030 0,762	9
31,75	20	1.2500 31,750	2.0000 50,800	0.937 23,800	1.093 27,762	1.445 36,700	0.010 0,254	0.030 0,762	6
38,10	24	1.5000 38,100	2.4375 61,913	1.135 28,830	1.312 33,325	1.870 47,500	0.010 0,254	0.030 0,762	6
44,45	28	1.7500 44,450	2.8750 73,025	1.000 25,400	1.125 28,575	2.252 57,200	0.010 0,254	0.030 0,762	4

¹⁾ Values are given for non protected bearings. For sealed bearings, refer to page 140



Designation system

Examples:	ZWGT512,7E-2CP6RP01	Z	W	GT	S	12,7	E	-2	CP6	RP01
	QGTC24,4EECP109									
Surface treatment of outer ring										
No code	Not plated									
Z	Cadmium plated external dimensions									
SZ	Zinc-nickel plated external dimensions									
Material										
No code	Bearing steel inner ring and outer ring									
W	Corrosion-resistant steel inner ring and outer ring									
Q	Bronze beryllium inner ring and bearing steel outer ring									
Basic designation										
Lubrication grooves and axial clearance										
No code	Without lubrication groove and reduced axial clearance									
S	Lubrication by inner ring and standard axial clearance									
C	Lubrication by outer ring and standard axial clearance									
Y	Lubrication by inner and outer ring and standard axial clearance									
Bore code										
Seal										
No code	No seal									
E	Sealed on the slot side									
EE	Sealed on both sides									
Lubricant										
No code	Grease G354									
-2	Grease G395									
Surface treatment of inner ring										
No code	Not plated									
CP6 ¹⁾	Chromium plated sphere									
CP109 ¹⁾	XCR plating on sphere (chromium 6 free replacement to chromium plating)									
CP55 ¹⁾	Passivated corrosion-resistant steel inner ring									
Oversize										
No code	Standard outer diameter size									
RP01	0.010 in/0,254 mm oversized outer diameter									
RP02	0.020 in/0,508 mm oversized outer diameter									

¹⁾ Available only for inner ring in corrosion-resistant steel material

Loads and clearance

Nominal bore code	Dash number multiples of 1/16 inch	Mass =	Static limit loads ²⁾		Axial clearance	
			Radial C _s	Axial C _a	Standard GT	Reduced GTS GTC GTY
		lb/g	lbf/kN	in/μm		
12,7	08	0.07	20 520	1 395	0.0002/0.0010	0.0006/0.0015
		30	91,7	6,2	5/25	15/38
14,29	09	0.09	26 460	1 800	0.0002/0.0010	0.0006/0.0015
		39	117,7	8,0	5/25	15/38
15,87	10	0.11	32 940	2 452	0.0002/0.0010	0.0006/0.0015
		52	146,5	10,9	5/25	15/38
19,05	12	0.20	47 655	3 465	0.0004/0.0012	0.0007/0.0018
		92	212,0	15,4	10/32	19/45
22,22	14	0.26	62 640	4 972	0.0004/0.0012	0.0007/0.0018
		0,117	278,6	22,1	10/32	19/45
25,4	16	0.37	89 550	7 178	0.0004/0.0012	0.0007/0.0018
		170	398,4	31,9	10/32	19/45
31,75	20	0.51	126 517	10 102	0.0006/0.0015	0.0010/0.0020
		230	562,8	44,9	10/32	25/51
38,10	24	0.86	188 437	16 132	0.0006/0.0015	0.0010/0.0020
		0,390	838,2	71,8	10/32	25/51
44,45	28	1.17	202 500	12 532	0.0006/0.0015	0.0010/0.0020
		530	900,8	55,7	10/32	25/51

²⁾ Loads are given in the opposite direction to the slots and are valid for the steel/steel spherical plain bearings without lubrication groove. For other bearings, refer to page 134

2.11 Metal-to-metal swaged narrow (inch dimensions)

ME.. bore code 4,83 to 14,29

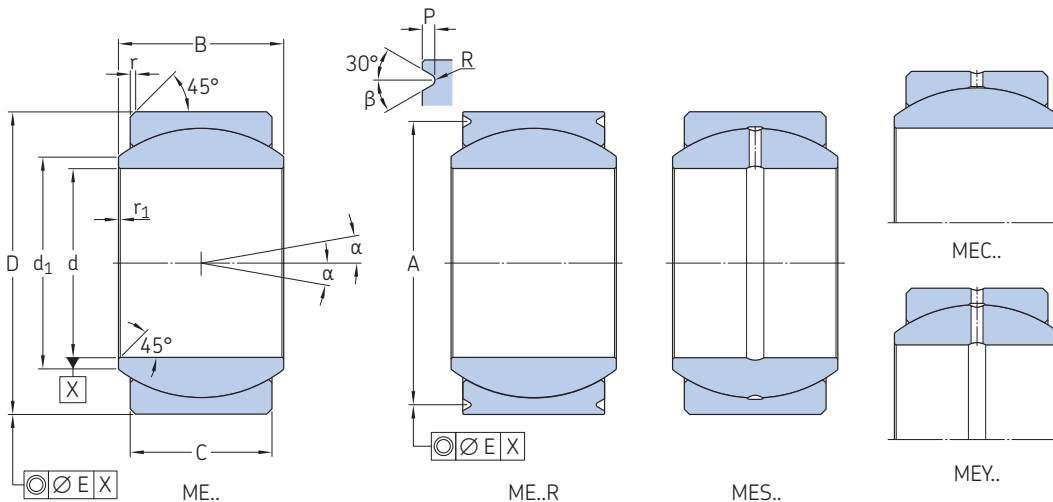

Technical specification	AS 8976
Product standards	AS 21154 (grooved) AS 21155 (chamfered)

d	β	E
in/mm	°	in/mm
0.1900/0.3125 4,826/7,938	20	0.003 0,076
0.3750/1.7500 9,525/44,450	30	0.005 0,127

Dimensions

Nominal bore code	Dash number multiples of 1/16 inch	Dimensions		D	C	B	d ₁	r ₁	r	A	P
		d	D								
		0/-0.0005 0/-0,0127	0/-0.0005 0/-0,0127		±0.005 ±0,127	0/-0.002 0/-0,051	≈	±0.005 ±0,127	+0.010/0 +0,254/0	0/-0.008 0/-0,203	0/-0.010 0/-0,254
– in/mm											
4,83	03	0.1900 4,826	0.5625 14,288	0.218 5,537	0.281 7,137	0.293 7,442		0.010 0,254	0.010 0,254	0.502 12,751	0.030 0,762
6,35	04	0.2500 6,350	0.6562 16,667	0.250 6,350	0.343 8,712	0.364 9,246		0.010 0,254	0.010 0,254	0.596 15,140	0.030 0,762
7,94	05	0.3125 7,938	0.7500 19,050	0.281 7,137	0.375 9,525	0.419 10,643		0.010 0,254	0.010 0,254	0.662 16,815	0.040 1,016
9,52	06	0.3750 9,525	0.8125 20,638	0.312 7,925	0.406 10,312	0.475 12,065		0.010 0,254	0.020 0,508	0.714 18,136	0.040 1,016
11,11	07	0.4375 11,113	0.9062 23,017	0.343 8,712	0.437 11,100	0.530 13,462		0.010 0,254	0.020 0,508	0.808 20,523	0.040 1,016
12,7	08	0.5000 12,700	1.0000 25,400	0.390 9,906	0.500 12,700	0.600 15,240		0.010 0,254	0.020 0,508	0.878 22,301	0.060 1,524
14,29	09	0.5625 14,288	1.0937 27,780	0.437 11,100	0.562 14,275	0.670 17,018		0.010 0,254	0.020 0,508	0.972 24,689	0.060 1,524

Dimensions cont., d and clearance

Nominal bore code	Dash number multiples of 1/16 inch	Dimensions		Mass =	Static limit loads ³⁾		Radial clearance	Axial clearance	Max	Standard	Reduced
		R	α ⁴⁾		Radial C _s	Axial C _a ¹⁾					
		in/mm	°	lb/g	lbf/kN		in/μm				
4,83	03	0.005/0.010 0,127/0,254	10	0.02 9	6 300 28	2 475 11	0.0005/0.0020 12,7/50	0.010 254	0.0020/0.0040 50/100	0.0002/0.0020 5/50	
6,35	04	0.005/0.010 0,127/0,254	13	0.02 9	9 450 42	3 600 16	0.0005/0.0020 12,7/50	0.010 254	0.0020/0.0040 50/100	0.0002/0.0020 5/50	
7,94	05	0.005/0.010 0,127/0,254	10	0.03 14	12 825 57	5 175 23	0.0005/0.0020 12,7/50	0.010 254	0.0020/0.0040 50/100	0.0002/0.0020 5/50	
9,52	06	0.010/0.020 0,254/0,508	9	0.04 18	15 750 70	5 625 25	0.0005/0.0020 12,7/50	0.010 254	0.0020/0.0040 50/100	0.0002/0.0020 5/50	
11,11	07	0.010/0.020 0,254/0,508	8	0.05 22	19 125 85	7 650 34	0.0005/0.0020 12,7/50	0.010 254	0.0020/0.0040 50/100	0.0002/0.0020 5/50	
12,7	08	0.010/0.020 0,254/0,508	8	0.07 31	24 750 110	8 775 39	0.0005/0.0020 12,7/50	0.010 254	0.0020/0.0040 50/100	0.0002/0.0020 5/50	
14,29	09	0.010/0.020 0,254/0,508	9	0.09 40	32 400 144	10 575 47	0.0005/0.0020 12,7/50	0.010 254	0.0020/0.0040 50/100	0.0002/0.0020 5/50	

¹⁾ These values can be limited by the unstaking load (contact SKF for more information)

³⁾ Loads are valid for the steel/steel spherical plain bearings. For other bearings, refer to page 134

⁴⁾ Values are given for non protected bearings. For sealed and shielded bearings, refer to page 140



Designation system

Examples: ZWQMES12,7RXTT-2CP6RP01
QME25,4PPCP109

Surface treatment of outer ring

No code¹⁾ Not plated
Z Cadmium plated external dimensions
SZ Zinc-nickel plated external dimensions

Material code **Inner ring material** **External ring material**
W Corrosion-resistant steel Corrosion-resistant steel
Q¹⁾ Bronze beryllium Corrosion-resistant steel
WQ Corrosion-resistant steel Bronze aluminium

Basic designation

Lubrication grooves

No code¹⁾ Without lubrication groove
S¹⁾ Lubrication by inner ring
C¹⁾ 3) Lubrication by outer ring
Y Lubrication by inner and outer ring

Bore code

Chamfer and groove

No code Chamfered outer ring
R Grooved outer ring

Axial clearance

No code Standard axial clearance
X¹⁾ Reduced axial clearance

Shield and seal

No code No shield and seal
TT^{1) 4)} Sealed
PP^{1) 4)} Shielded

Lubricant

No code¹⁾ Grease G354
-2¹⁾ Grease G395
-4 Grease G353

Surface treatment of inner ring

No code¹⁾ Not plated
CP6⁵⁾ Chromium plated sphere
CP109²⁾ XCR plating on sphere (chromium 6 free replacement to chromium plating)
CP55²⁾ Passivated corrosion-resistant steel inner ring

Oversize

No code Standard outer diameter size
RP01¹⁾ 0.010 in/0,254 mm oversized outer diameter
RP02¹⁾ 0.020 in/0,508 mm oversized outer diameter

1) SKF option

2) SKF option, available only for inner ring in corrosion-resistant steel material

3) In the outer ring sphere, central lubrication groove only for $d \leq 7,94$

4) Only available for $d \geq 7,94$

5) Available only for inner ring in corrosion-resistant steel material

2.11 Metal-to-metal swaged narrow (inch dimensions)

ME.. bore code 15,87 to 44,4

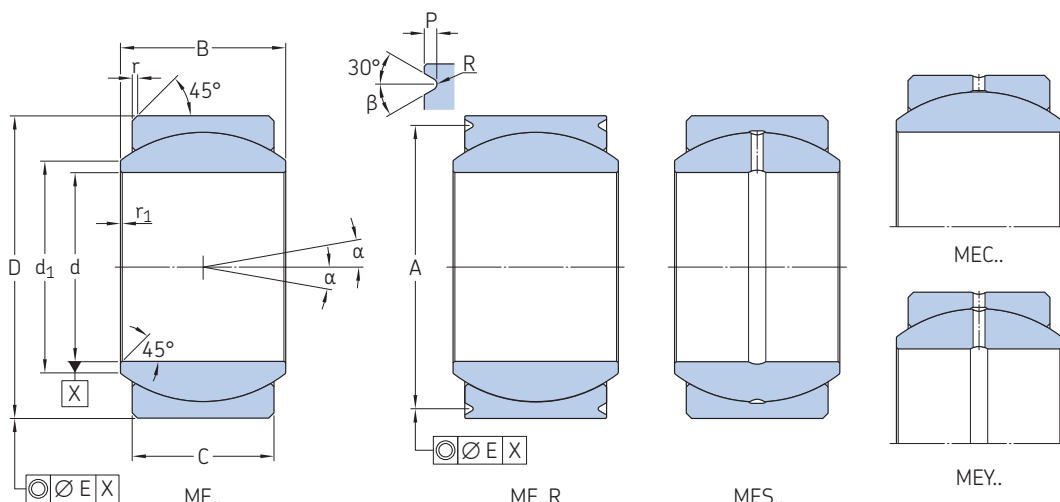

Technical specification	AS 8976
Product standards	AS 21154 (grooved) AS 21155 (chamfered)

d	β	E
in/mm	°	in/mm
0.1900/0.3125 4,826/7,938	20	0.003 0,076
0.3750/1.7500 9,525/44,450	30	0.005 0,127

2.11



Dimensions

Nominal bore code	Dash number multiples of 1/16 inch	Dimensions									
		d	D	C	B	d ₁	r ₁	r	A	P	
		0/-0.0005 0/-0,0127	0/-0.0005 0/-0,0127	±0.005 ±0,127	0/-0.002 0/-0,051	≈	±0.005 ±0,127	0/-0.010 0/-0,254	0/-0.008 0/-0,203	0/-0.010 0/-0,254	
		in/mm									
15,87	10	0.6250	1.1875	0.500	0.625	0.739	0.010	0.020	1.065	0.060	
		15,875	30,163	12,700	15,875	18,771	0,254	0,508	27,051	1,524	
19,05	12	0.7500	1.4375	0.593	0.750	0.920	0.010	0.030	1.315	0.060	
		19,050	36,513	15,062	19,050	23,368	0,254	0,762	33,401	1,524	
22,22	14	0.8750	1.5625	0.703	0.875	0.980	0.010	0.030	1.440	0.060	
		22,225	39,688	17,856	22,225	24,892	0,254	0,762	36,576	1,524	
25,4	16	1.0000	1.7500	0.797	1.000	1.118	0.010	0.030	1.628	0.060	
		25,400	44,450	20,244	25,400	28,397	0,254	0,762	41,351	1,524	
31,75 ²⁾	20	1.2500	2.0000	0.937	1.093	1.445	0.010	0.030	1.878	0.060	
		31,750	50,800	23,800	27,762	36,700	0,254	0,762	47,701	1,524	
38,10 ²⁾	24	1.5000	2.4375	1.135	1.312	1.870	0.010	0.030	2.317	0.060	
		38,100	61,913	28,830	33,325	47,500	0,254	0,762	58,850	1,524	
44,4 ²⁾	28	1.7500	2.8750	1.000	1.125	2.252	0.010	0.030	2.753	0.060	
		44,450	73,025	25,400	28,575	57,200	0,254	0,762	69,930	1,524	

Dimensions cont., loads and clearance

Nominal bore code	Dash number multiples of 1/16 inch	Dimensions		Mass ≈	Static limit load ³⁾		Radial clearance For products per AS standard	Axial clearance		
		R	α ⁴⁾		Radial C _s	Axial C _{a1} ¹⁾		Max	Standard For other products	Reduced
		in/mm	°	lb/g	lbf/kN	in/μm				
15,87	10	0.010/0.020	8	0.12	41 175	14 175	0.0005/0.0020	0.010	0.0020/0.0040	0.0002/0.0020
		0.254/0.508		54	183	63	12,7/50	254	50/100	5/50
19,05	12	0.010/0.020	8	0.21	59 850	19 125	0.0005/0.0020	0.010	0.0020/0.0040	0.0002/0.0020
		0.254/0.508		95	266	85	12,7/50	254	50/100	5/50
22,22	14	0.010/0.020	8	0.27	78 750	27 900	0.0005/0.0020	0.010	0.0024/0.0047	0.0002/0.0024
		0.254/0.508		122	350	124	12,7/50	254	60/120	5/60
25,4	16	0.010/0.020	9	0.39	101 700	35 550	0.0005/0.0020	0.010	0.0024/0.0047	0.0002/0.0024
		0.254/0.508		176	452	158	12,7/50	254	60/120	5/60
31,75 ²⁾	20	0.010/0.020	6	0.53	142 875	52 875	0.0005/0.0020	0.010	0.0024/0.0047	0.0002/0.0024
		0.254/0.508		240	636	235	12,7/50	254	60/120	5/60
38,10 ²⁾	24	0.010/0.020	6	0.89	216 675	81 675	0.0005/0.0020	0.010	0.0024/0.0047	0.0002/0.0024
		0.254/0.508		405	964	363	12,7/50	254	60/120	5/60
44,45 ²⁾	28	0.010/0.020	4	1.20	216 675	50 829	0.0005/0.0020	0.010	0.0024/0.0047	0.0002/0.0024
		0.254/0.508		545	964	226	12,7/50	254	60/120	5/60

¹⁾ These values can be limited by the unstaking load (contact SKF for more information)

²⁾ SKF option

³⁾ Loads are valid for the steel/steel spherical plain bearings. For other bearings, refer to page 134

⁴⁾ Values are given for non protected bearings. For sealed and shielded bearings, refer to page 140



Designation system

Examples: ZWQMES12,7RXTT-2CP6RP01
QME25,4PPCP109

Surface treatment of outer ring

No code¹⁾ Not plated
Z Cadmium plated external dimensions
SZ Zinc-nickel plated external dimensions

Material code **Inner ring material** **External ring material**
W Corrosion-resistant steel Corrosion-resistant steel
Q¹⁾ Bronze beryllium Corrosion-resistant steel
WQ Corrosion-resistant steel Bronze aluminium

Basic designation

Lubrication grooves

No code¹⁾ Without lubrication groove
S¹⁾ Lubrication by inner ring
C¹⁾ 3) Lubrication by outer ring
Y Lubrication by inner and outer ring

Bore code

Chamfer and groove

No code Chamfered outer ring
R Grooved outer ring

Axial clearance

No code Standard axial clearance
X¹⁾ Reduced axial clearance

Shield and seal

No code No shield and seal
TT^{1) 4)} Sealed
PP^{1) 4)} Shielded

Lubricant

No code¹⁾ Grease G354
-2¹⁾ Grease G395
-4 Grease G353

Surface treatment of inner ring

No code¹⁾ Not plated
CP6⁵⁾ Chromium plated sphere
CP109²⁾ XCR plating on sphere (chromium 6 free replacement to chromium plating)
CP55²⁾ Passivated corrosion-resistant steel inner ring

Oversize

No code Standard outer diameter size
RP01¹⁾ 0.010 in/0,254 mm oversized outer diameter
RP02¹⁾ 0.020 in/0,508 mm oversized outer diameter

1) SKF option

2) SKF option, available only for inner ring in corrosion-resistant steel material

3) In the outer ring sphere, central lubrication groove only for $d \leq 7,94$

4) Only available for $d \geq 7,94$

5) Available only for inner ring in corrosion-resistant steel material

2.12 Metal-to-metal swaged narrow (inch dimensions)

ENE.. bore code **4,83** to **15,87**

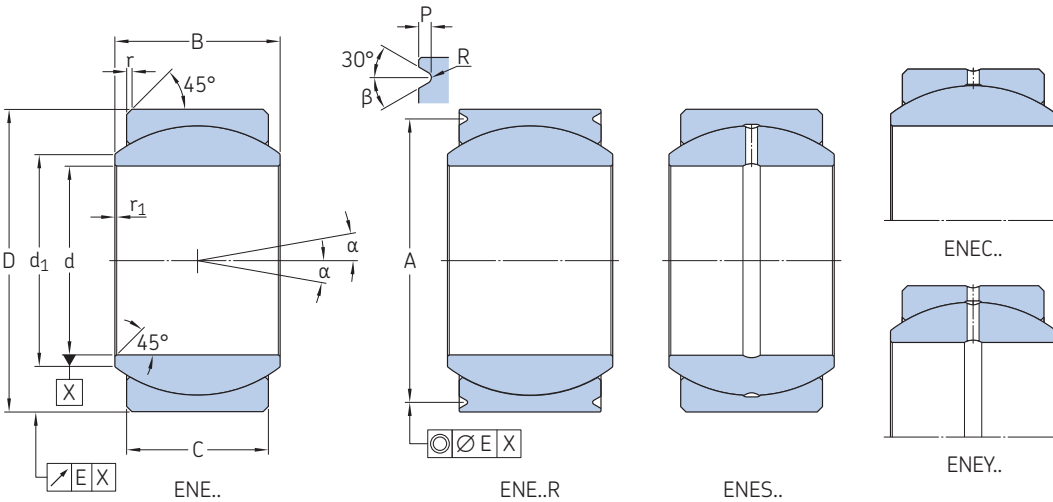

Technical specification	EN 2337
Product standards	EN 6046
Materials	Corrosion-resistant steel inner ring and outer ring

d	β	E
in/mm	°	in/mm
0.1900/0.3125 4,826/7,938	20	0.003 0,076
0.3750/1.7500 9,525/44,450	30	0.005 0,127

Dimensions

Nominal bore code	Dash number multiples of 1/16 inch	Dimensions d	Δdmp	Δds	D	ΔDmp	ΔDs	C +0.005/0 +0,127/0	B 0/-0.002 0/-0,051
in/mm									
4,83	03	0.1900 4,826	0/-0.0005 0/-0,0127	0/-0.0005 0/-0,0127	0.5625 14,288	0/-0.0003 0/-0,008	0/-0.0005 0/-0,0127	0.218 5,537	0.281 7,137
6,35	04	0.2500 6,350	0/-0.0005 0/-0,0127	0/-0.0005 0/-0,0127	0.6562 16,667	0/-0.0003 0/-0,008	0/-0.0005 0/-0,0127	0.250 6,350	0.343 8,712
7,94	05	0.3125 7,938	0/-0.0005 0/-0,0127	0/-0.0005 0/-0,0127	0.7500 19,050	0/-0.0003 0/-0,008	0/-0.0005 0/-0,0127	0.281 7,137	0.375 9,525
9,52	06	0.3750 9,525	0/-0.0005 0/-0,0127	0/-0.0005 0/-0,0127	0.8125 20,638	0/-0.0004 0/-0,009	0/-0.0005 0/-0,0127	0.312 7,925	0.406 10,312
11,11	07	0.4375 11,113	0/-0.0005 0/-0,0127	0/-0.0005 0/-0,0127	0.9062 23,017	0/-0.0004 0/-0,009	0/-0.0005 0/-0,0127	0.343 8,712	0.437 11,100
12,7	08	0.5000 12,700	0/-0.0005 0/-0,0127	0/-0.0005 0/-0,0127	1.0000 25,400	0/-0.0004 0/-0,009	0/-0.0005 0/-0,0127	0.390 9,906	0.500 12,700
14,29	09	0.5625 14,288	0/-0.0005 0/-0,0127	0/-0.0005 0/-0,0127	1.0937 27,780	0/-0.0004 0/-0,009	0/-0.0005 0/-0,0127	0.437 11,100	0.562 14,275
15,87	10	0.6250 15,875	0/-0.0005 0/-0,0127	0/-0.0005 0/-0,0127	1.1875 30,163	0/-0.0004 0/-0,009	0/-0.0005 0/-0,0127	0.500 12,700	0.625 15,875

Dimensions cont.

Nominal bore code	Dash number multiples of 1/16 inch	Dimensions d1 ≈	r1 ±0.005 ±0,127	r 0/-0.010 0/-0,254	A 0/-0.008 0/-0,203	P 0/-0.010 0/-0,254	R	α ⁽⁶⁾	Mass ≈
in/mm									lb/g
4,83	03	0.293 7,442	0.010 0,254	0.025 0,635	0.500 12,700	0.025 0,640	0.005/0.010 0,127/0,254	10	0.02 7
6,35	04	0.364 9,246	0.010 0,254	0.025 0,635	0.594 15,088	0.025 0,640	0.005/0.010 0,127/0,254	13	0.02 11
7,94	05	0.419 10,643	0.010 0,254	0.025 0,635	0.660 16,764	0.035 0,890	0.005/0.010 0,127/0,254	11	0.03 14
9,52	06	0.475 12,065	0.010 0,254	0.030 0,762	0.712 18,085	0.035 0,890	0.010/0.017 0,254/0,432	9	0.04 18
11,11	07	0.530 13,462	0.010 0,254	0.030 0,762	0.808 20,523	0.035 0,890	0.010/0.017 0,254/0,432	9	0.05 23
12,7	08	0.600 15,24	0.010 0,254	0.030 0,762	0.876 22,250	0.055 1,400	0.010/0.017 0,254/0,432	9	0.07 32
14,29	09	0.670 17,018	0.010 0,254	0.030 0,762	0.970 24,638	0.055 1,400	0.010/0.017 0,254/0,432	10	0.09 41
15,87	10	0.739 18,771	0.010 0,254	0.030 0,762	1.063 27,000	0.055 1,400	0.010/0.017 0,254/0,432	9	0.12 54



Designation system

Examples:	ZENES12,7RXTT-2CP6RP01	Z	ENE	S	12,7	R	X	TT	-2	CP6	RP01
	ENEC25,4PPCP109										
Surface treatment of outer ring											
No code	Not plated										
Z	Cadmium plated external dimensions										
SZ ¹⁾	Zinc-nickel plated external dimensions										
Basic designation											
Lubrication grooves											
No code	Without lubrication groove										
S	Lubrication by inner ring										
C ²⁾	Lubrication by outer ring										
Y ¹⁾	Lubrication by inner and outer ring										
Bore code											
Chamfer and groove											
No code	Chamfered outer ring										
R	Grooved outer ring										
Clearances											
No code	Standard clearances										
X	Reduced clearances										
Shield and seal											
No code	No shield and seal										
TT ^{1) 3)}	Sealed										
PP ^{1) 3)}	shielded										
Lubricant											
No code	Grease G354										
-2	Grease G395										
Surface treatment of inner ring											
No code	Passivated inner ring										
CP6 ¹⁾	Chromium plated sphere										
CP109 ¹⁾	XCR plating on sphere (chromium 6 free replacement to chromium plating)										
Over-size											
No code	Standard outer diameter size										
RP01 ¹⁾	0.010 in/0,254 mm oversized outer diameter										
RP02 ¹⁾	0.020 in/0,508 mm oversized outer diameter										

1) SKF option

2) In the outer ring sphere, central lubrication groove only for $d \leq 7,94$

3) Only available for $d \geq 7,94$

Loads and clearance

Nominal bore code	Dash number multiples of 1/16 inch	Static limit loads ⁵⁾		Standard clearances		Reduced clearances	
		Radial C_s	Axial C_a ⁴⁾	Radial	Axial max	Radial	Axial max
		lbf/kN		in/ μ m			
4,83	03	6 300	2 475	0.0004/0.0012	0.0050	0.0001/0.0004	0.0014
		28	11	10/30	127	2/10	35
6,35	04	9 450	3 600	0.0004/0.0012	0.0050	0.0001/0.0004	0.0014
		42	16	10/30	127	2/10	35
7,94	05	12 825	5 175	0.0004/0.0012	0.0050	0.0001/0.0004	0.0014
		57	23	10/30	127	2/10	35
9,52	06	15 750	5 625	0.0004/0.0012	0.0050	0.0001/0.0004	0.0014
		70	25	10/30	127	2/10	35
11,11	07	19 125	7 650	0.0004/0.0012	0.0050	0.0001/0.0004	0.0014
		85	34	10/30	127	2/10	35
12,7	08	24 750	8 775	0.0004/0.0020	0.0090	0.0001/0.0004	0.0014
		110	39	10/50	229	2/10	35
14,29	09	32 400	10 575	0.0004/0.0020	0.0090	0.0001/0.0005	0.0016
		144	47	10/50	229	3/12	40
15,87	10	41 175	14 175	0.0004/0.0020	0.0090	0.0001/0.0005	0.0016
		183	63	10/50	229	3/12	40

4) These values can be limited by unstaking load (contact SKF for more information)

5) Loads are valid for the spherical plain bearings without lubrication groove. For other bearings, refer to page 134

6) Values are given for non protected bearings. For sealed and shielded bearings, refer to page 140

2.12 Metal-to-metal swaged narrow (inch dimensions)

ENE.. bore code 19,05 to 50,8

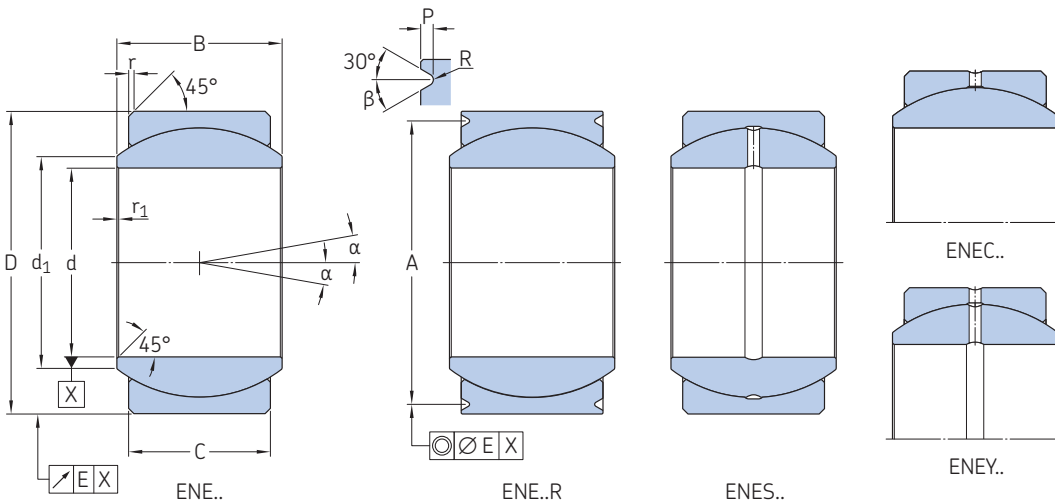

Technical specification	EN 2337
Product standards	EN 6046
Materials	Corrosion-resistant steel inner ring and outer ring

d	β	E
in/mm	°	in/mm
0.1900/0.3125 4,826/7,938	20	0.003 0,076
0.3750/1.7500 9,525/44,450	30	0.005 0,127

2.12

Dimensions

Nominal bore code	Dash number multiples of 1/16 inch	Dimensions			D	ΔDmp	ΔDs	C +0,005/0 +0,127/0	B 0/-0,002 0/-0,051
		d	Δdmp	Δds					
in/mm									
19,05	12	0.7500	0/-0,0005	0/-0,0005	1.4375	0/-0,0004	0/-0,0005	0.593	0.750
		19,050	0/-0,0127	0/-0,0127	36,513	0/-0,011	0/-0,0127	15,062	19,050
22,22	14	0.8750	0/-0,0005	0/-0,0005	1.5625	0/-0,0004	0/-0,0005	0.703	0.875
		22,225	0/-0,0127	0/-0,0127	39,688	0/-0,011	0/-0,0127	17,856	22,225
25,4	16	1.0000	0/-0,0005	+0,0001/-0,0006	1.7500	0/-0,0005	+0,0001/-0,0006	0.797	1.000
		25,400	0/-0,0127	+0,0025/-0,0152	44,450	0/-0,013	+0,0025/-0,0152	20,244	25,400
31,75	20	1.2500	0/-0,0005	+0,0001/-0,0006	2.0000	0/-0,0005	+0,0001/-0,0006	0.942	1.093
		31,750	0/-0,0127	+0,0025/-0,0152	50,800	0/-0,013	+0,0025/-0,0152	23,927	27,762
38,10	24	1.5000	0/-0,0005	+0,0001/-0,0006	2.4375	0/-0,0005	+0,0001/-0,0006	1.130	1.312
		38,100	0/-0,0127	+0,0025/-0,0152	61,913	0/-0,013	+0,0025/-0,0152	28,702	33,325
44,45	28	1.7500	0/-0,0005	+0,0001/-0,0006	2.8125	0/-0,0005	+0,0001/-0,0006	1.317	1.531
		44,450	0/-0,0127	+0,0025/-0,0152	71,438	0/-0,013	+0,0025/-0,0152	33,452	38,887
50,8	32	2.0000	0/-0,0005	+0,0001/-0,0006	3.1875	0/-0,0005	+0,0001/-0,0006	1.505	1.750
		50,800	0/-0,0127	+0,0025/-0,0152	80,963	0/-0,013	+0,0025/-0,0152	38,227	44,450

Dimensions cont.

Nominal bore code	Dash number multiples of 1/16 inch	Dimensions			A	P	R	α ⁽⁶⁾	Mass ≈
		d ₁	r ₁	r					
in/mm									
19,05	12	0.920	0.010	0.040	1.313	0.055	0.010/0.017	9	0.21
		23,368	0,254	1,016	33,350	1,400	0,254/0,432		
22,22	14	0.980	0.010	0.040	1.438	0.055	0.010/0.017	9	0.27
		24,892	0,254	1,016	36,525	1,400	0,254/0,432		
25,4	16	1.118	0.010	0.040	1.626	0.055	0.010/0.017	9	0.38
		28,397	0,254	1,016	41,300	1,400	0,254/0,432		
31,75	20	1.445	0.010	0.040	1.876	0.055	0.010/0.017	6	0.53
		36,700	0,254	1,016	47,650	1,400	0,254/0,432		
38,10	24	1.870	0.010	0.040	2.313	0.055	0.010/0.017	6	0.97
		47,500	0,254	1,016	58,750	1,400	0,254/0,432		
44,45	28	1.996	0.010	0.040	2.688	0.055	0.010/0.017	6	1.47
		50,698	0,254	1,016	68,275	1,400	0,254/0,432		
50,8	32	2.440	0.010	0.040	3.064	0.055	0.010/0.017	5	2.16
		61,976	0,254	1,016	77,826	1,400	0,254/0,432		



Designation system

Examples:	ZENES12,7RXTT-2CP6RP01	Z	ENE	S	12,7	R	X	TT	-2	CP6	RP01
	ENEC25,4PPCP109										
Surface treatment of outer ring											
No code	Not plated										
Z	Cadmium plated external dimensions										
SZ ¹⁾	Zinc-nickel plated external dimensions										
Basic designation											
Lubrication grooves											
No code	Without lubrication groove										
S	Lubrication by inner ring										
C ²⁾	Lubrication by outer ring										
Y ¹⁾	Lubrication by inner and outer ring										
Bore code											
Chamfer and groove											
No code	Chamfered outer ring										
R	Grooved outer ring										
Clearances											
No code	Standard clearances										
X	Reduced clearances										
Shield and seal											
No code	No shield and seal										
TT ^{1) 3)}	Sealed										
PP ^{1) 3)}	shielded										
Lubricant											
No code	Grease G354										
-2	Grease G395										
Surface treatment of inner ring											
No code	Passivated inner ring										
CP6 ¹⁾	Chromium plated sphere										
CP109 ¹⁾	XCR plating on sphere (chromium 6 free replacement to chromium plating)										
Oversize											
No code	Standard outer diameter size										
RP01 ¹⁾	0.010 in/0,254 mm oversized outer diameter										
RP02 ¹⁾	0.020 in/0,508 mm oversized outer diameter										

¹⁾ SKF option

²⁾ In the outer ring sphere, central lubrication groove only for $d \leq 7,94$

³⁾ Only available for $d \geq 7,94$

Loads and clearance

Nominal bore code	Dash number multiples of 1/16 inch	Static limit loads ⁵⁾		Standard clearances		Reduced clearances	
		Radial C_s	Axial C_a ⁴⁾	Radial	Axial max	Radial	Axial max
–		lbf/kN		in/ μ m			
19,05	12	59 850	19 125	0.0004/0.0020	0.0090	0.00015/0.0006	0.0020
		266	85	10/50	229	4/15	50
22,22	14	78 750	27 900	0.0004/0.0020	0.0090	0.00015/0.0006	0.0020
		350	124	10/50	229	4/15	50
25,4	16	101 700	35 550	0.0004/0.0020	0.0090	0.00015/0.0006	0.0020
		452	158	10/50	229	4/15	50
31,75	20	142 875	52 875	0.0004/0.0020	0.0090	0.00015/0.0006	0.0020
		636	235	10/50	229	4/15	50
38,10	24	216 675	81 675	0.0004/0.0020	0.0090	0.0001/0.0004	0.0020
		964	363	10/50	229	4/15	50
44,45	28	282 375	108 000	0.0004/0.0020	0.0090	0.00015/0.0006	0.0020
		1 256	480	10/50	229	4/15	50
50,8	32	387 000	148 725	0.0004/0.0020	0.0090	0.0002/0.0008	0.0024
		1 721	662	10/50	229	5/20	60

⁴⁾ These values can be limited by unstaking load (contact SKF for more information)

⁵⁾ Loads are valid for the spherical plain bearings without lubrication groove. For other bearings, refer to page 134

⁶⁾ Values are given for non protected bearings. For sealed and shielded bearings, refer to page 140

2.13 Metal-to-metal swaged wide (inch dimensions)

ML.. bore code **4,83** to **15,87**

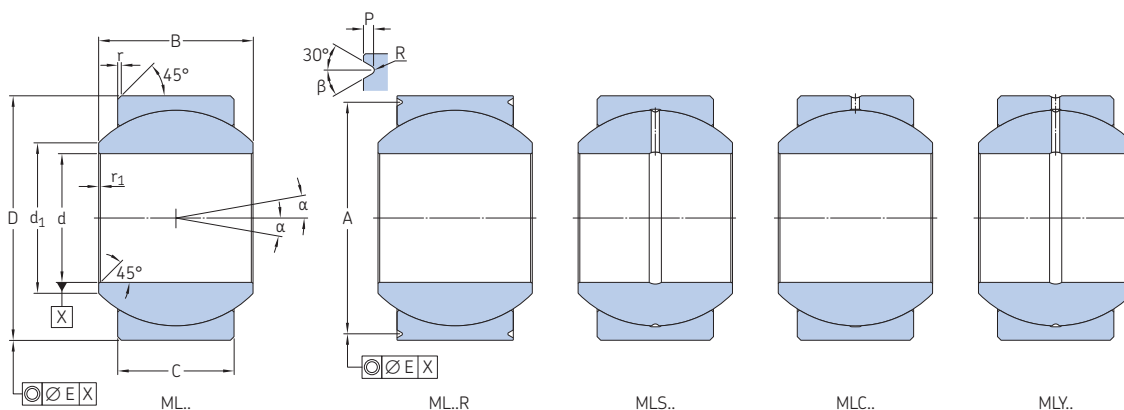

Technical specification –
Product standards –

d	β	E
in/mm	°	in/mm
0.1900/ 0.2500 4,826/ 6,35	20	0.003 0,076
0.3125 7,938	30	0.003 0,076
0.3750/ 2.0000 9,525/ 50,8	30	0.005 0,127

Dimensions

Nominal bore code	Dash number multiples of 1/16 inch	Dimensions								
		d	D	C	B	d ₁	r ₁	r	A	P
		0/–0.0005 0/–0,0127	0/–0.0005 0/–0,0127	±0.005 ±0,127	0/–0.002 0/–0,051	≈	±0.005 ±0,127	0.010/–0 0,254/–0	0/–0.008 0/–0,203	0/–0.010 0/–0,254
		in/mm								
4,83	03	0.1900	0.6250	0.327	0.437	0.300	0.010	0.015	0.563	0.025
		4,826	15,875	8,306	11,100	7,620	0,254	0,381	14,300	0,635
6,35	04	0.2500	0.6250	0.327	0.437	0.300	0.010	0.015	0.563	0.025
		6,350	15,875	8,306	11,100	7,620	0,254	0,381	14,300	0,635
7,94	05	0.3125	0.6875	0.317	0.437	0.360	0.010	0.015	0.625	0.025
		7,938	17,462	8,052	11,100	9,140	0,254	0,381	15,875	0,635
9,52	06	0.3750	0.8125	0.406	0.500	0.466	0.010	0.020	0.712	0.035
		9,525	20,638	10,312	12,700	11,840	0,254	0,508	18,085	0,889
11,11	07	0.4375	0.9375	0.442	0.562	0.537	0.010	0.020	0.837	0.035
		11,113	23,812	11,227	14,275	13,64	0,254	0,508	21,260	0,889
12,7	08	0.5000	1.0000	0.505	0.625	0.607	0.010	0.020	0.900	0.035
		12,700	25,400	12,827	15,875	15,420	0,254	0,508	22,860	0,889
14,29	09	0.5625	1.1250	0.536	0.687	0.721	0.010	0.020	1.025	0.035
		14,288	28,575	13,614	17,450	18,310	0,254	0,508	26,035	0,889
15,87	10	0.6250	1.1875	0.567	0.750	0.747	0.010	0.020	1.087	0.035
		15,875	30,163	14,400	19,050	18,970	0,254	0,508	27,610	0,889

Dimensions cont., loads and clearance

Nominal bore code	Dash number multiples of 1/16 inch	Dimensions		Mass =	Static limit loads ²⁾		Axial clearance	
		R	α ³⁾		Radial	Axial	Standard	Reduced
		in/mm	°	lb/g	lbf/kN	in/μm		
4,83	03	0.005/0.012	15	0.03	12 150	5 175	0.0020/0.0040	0.0002/0.0020
		0,127/0,305		14	54	23	50/100	5/50
6,35	04	0.005/0.012	15	0.03	13 725	5 850	0.0020/0.0040	0.0002/0.0020
		0,127/0,305		14	61	26	50/100	5/50
7,94	05	0.005/0.012	14	0.035	14 175	5 400	0.0020/0.0040	0.0002/0.0020
		0,127/0,305		16	63	24	50/100	5/50
9,52	06	0.010/0.017	8	0.06	21 375	8 325	0.0020/0.0040	0.0002/0.0020
		0,254/0,432		27	95	37	50/100	5/50
11,11	07	0.010/0.017	10	0.08	27 000	10 575	0.0020/0.0040	0.0002/0.0020
		0,254/0,432		38	120	47	50/100	5/50
12,7	08	0.010/0.017	9	0.10	35 550	13 950	0.0020/0.0040	0.0002/0.0020
		0,254/0,432		45	158	62	50/100	5/50
14,29	09	0.010/0.017	10	0.14	43 875	16 200	0.0020/0.0040	0.0002/0.0020
		0,254/0,432		61	195	72	50/100	5/50
15,87	10	0.010/0.017	12	0.16	49 500	17 775	0.0020/0.0040	0.0002/0.0020
		0,254/0,432		73	220	79	50/100	5/50

¹⁾ These values can be limited by the unstaking load (contact SKF for more information)

²⁾ Loads are valid for the steel/steel spherical plain bearings without lubrication groove. For other bearings, refer to page 134

³⁾ Values are given for non protected bearings. For sealed and shielded bearings, refer to page 140



Designation system

Examples: ZWQMLS12,7RXTT-2CP6RP01
QML25,4PPCP109

Surface treatment of outer ring

No code Not plated
Z Cadmium plated external dimensions
SZ Zinc-nickel plated external dimensions

Material code **Inner ring material** **External ring material**
W Corrosion-resistant steel Corrosion-resistant steel
Q Bronze beryllium Corrosion-resistant steel
WQ Corrosion-resistant steel Bronze aluminium

Basic designation

Lubrication grooves

No code Without lubrication groove
S Lubrication by inner ring
C³⁾ Lubrication by outer ring
Y Lubrication by inner and outer ring

Bore code

Chamfer and groove

No code Chamfered outer ring
R Grooved outer ring

Axial clearance

No code Standard axial clearance
X Reduced axial clearance

Shield and seal

No code No shield and seal
TT⁴⁾ Sealed
PP⁴⁾ Shielded

Lubricant

No code Grease G354
-2 Grease G395

Surface treatment of inner ring

No code Not plated
CP6²⁾ Chromium plated
CP109²⁾ XCR plating on sphere (chromium 6 free replacement to chromium plating)
CP55²⁾ Passivated corrosion-resistant steel inner ring

Oversize

No code Standard outer diameter size
RP01 0.010 in/0,254 mm oversized outer diameter
RP02 0.020 in/0,508 mm oversized outer diameter

²⁾ Available only for inner ring in corrosion-resistant steel material

³⁾ In the outer ring sphere, central lubrication groove only for $d \leq 7,94$

⁴⁾ Only available for $d \geq 7,94$

2.13 Metal-to-metal swaged wide (inch dimensions)

ML.. bore code 19,05 to 50,8

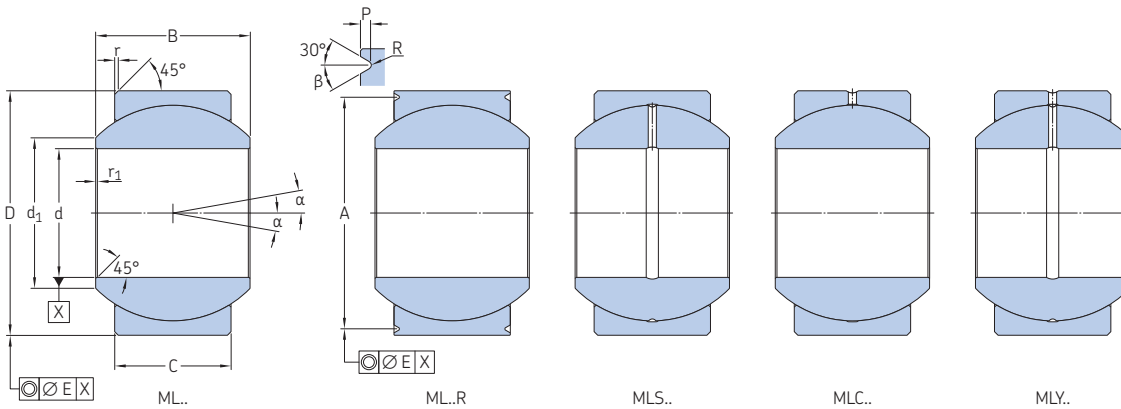

Technical specification –
Product standards –

d	β	E
in/mm	°	in/mm
0.1900/ 0.2500 4,826/ 6,35	20	0.003 0,076
0.3125/ 7,938	30	0.003 0,076
0.3750/ 2.0000 9,525/ 50,8	30	0.005 0,127

Dimensions

Nominal bore code	Dash number multiples of 1/16 inch	Dimensions		D	C	B	d ₁	r ₁	r	A	P
		d	E								
		0/–0.0005 0/–0,0127	0/–0.0005 0/–0,0127		±0.005 ±0,127	0/–0.002 0/–0,051	≈	±0.005 ±0,127	+0.010/0 +0,254/0	0/–0.008 0/–0,203	0/–0.010 0/–0,254
		in/mm									
19,05	12	0.7500 19,050	1.3750 34,925	0.630 16,002	0.875 22,225	0.845 21,460		0.010 0,254	0.030 0,762	1.251 31,775	0.055 1,397
22,22	14	0.8750 22,225	1.6250 41,275	0.755 19,177	0.875 22,225	0.995 25,270		0.010 0,254	0.030 0,762	1.501 38,125	0.055 1,397
25,4	16	1.0000 25,400	2.1250 53,975	1.005 25,527	1.375 34,925	1.269 32,230		0.010 0,254	0.030 0,762	2.001 50,825	0.055 1,397
31,75	20	1.2500 31,750	2.3750 60,325	1.130 28,702	1.500 38,100	1.462 37,150		0.010 0,254	0.030 0,762	2.253 57,230	0.060 1,524
38,10	24	1.5000 38,100	2.6875 68,260	1.223 31,064	1.687 42,850	1.697 43,100		0.010 0,254	0.030 0,762	2.565 65,160	0.060 1,524
44,45	28	1.7500 44,450	3.0000 76,200	1.317 33,452	1.812 46,020	1.965 49,900		0.010 0,254	0.030 0,762	2.878 73,100	0.060 1,524
50,8	32	2.0000 50,800	3.2500 82,550	1.380 35,050	1.937 49,190	2.209 56,100		0.010 0,254	0.030 0,762	3.128 79,451	0.060 1,524

Dimensions cont., loads and clearance

Nominal bore code	Dash number multiples of 1/16 inch	Dimensions		Mass ≈	Static limit loads ²⁾		Axial clearance	
		R	α ³⁾		Radial C _s	Axial C _a ¹⁾	Standard	Reduced
		in/mm		lb/g	lbf/kN		in/μm	
19,05	12	0.010/0.017 0.254/0.432	13	0.24 109	64 125 285	20 925 93	0.0020/0.0040 50/100	0.0002/0.0020 5/50
22,22	14	0.010/0.017 0.254/0.432	6	0.35 159	83 250 370	31 725 141	0.0024/0.0047 60/120	0.0002/0.0024 5/60
25,4	16	0.010/0.017 0.254/0.432	12	0.97 440	158 625 706	59 625 265	0.0024/0.0047 60/120	0.0002/0.0024 5/60
31,75	20	0.010/0.020 0.254/0.508	12	1.10 500	200 250 891	76 500 340	0.0024/0.0047 60/120	0.0002/0.0024 5/60
38,10	24	0.010/0.020 0.254/0.508	13	1.54 700	247 500 1 101	92 250 410	0.0024/0.0047 60/120	0.0002/0.0024 5/60
44,45	28	0.010/0.020 0.254/0.508	12	1.99 900	299 250 1 331	108 000 480	0.0024/0.0047 60/120	0.0002/0.0024 5/60
50,8	32	0.010/0.020 0.254/0.508	12	2.31 1 050	344 250 1 531	117 000 520	0.0024/0.0047 60/120	0.0002/0.0024 5/60

¹⁾ These values can be limited by the unstaking load (contact SKF for more information)

²⁾ Loads are valid for the steel/steel spherical plain bearings without lubrication groove. For other bearings, refer to page 134

³⁾ Values are given for non protected bearings. For sealed and shielded bearings, refer to page 140



Designation system

Examples: ZWQMLS12,7RXTT-2CP6RP01
QML25,4PPCP109

Surface treatment of outer ring

No code Not plated
Z Cadmium plated external dimensions
SZ Zinc-nickel plated external dimensions

Material code **Inner ring material** **External ring material**
W Corrosion-resistant steel Corrosion-resistant steel
Q Bronze beryllium Corrosion-resistant steel
WQ Corrosion-resistant steel Bronze aluminium

Basic designation

Lubrication grooves

No code Without lubrication groove
S Lubrication by inner ring
C³⁾ Lubrication by outer ring
Y Lubrication by inner and outer ring

Bore code

Chamfer and groove

No code Chamfered outer ring
R Grooved outer ring

Axial clearance

No code Standard axial clearance
X Reduced axial clearance

Shield and seal

No code No shield and seal
TT⁴⁾ Sealed
PP⁴⁾ Shielded

Lubricant

No code Grease G354
-2 Grease G395

Surface treatment of inner ring

No code Not plated
CP6²⁾ Chromium plated
CP109²⁾ XCR plating on sphere (chromium 6 free replacement to chromium plating)
CP55²⁾ Passivated corrosion-resistant steel inner ring

Oversize

No code Standard outer diameter size
RP01 0.010 in/0,254 mm oversized outer diameter
RP02 0.020 in/0,508 mm oversized outer diameter

²⁾ Available only for inner ring in corrosion-resistant steel material

³⁾ In the outer ring sphere, central lubrication groove only for $d \leq 7,94$

⁴⁾ Only available for $d \geq 7,94$

2.14 Metal-to-metal swaged wide (inch dimensions)

ENL.. bore code 4,83 to 14,29

Technical specification	EN 2337
Product standards	EN 4265 (Not plated) EN 4266 (Cadmium plated external dimensions)
Standard materials	Corrosion-resistant steel inner ring and outer ring

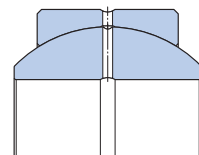
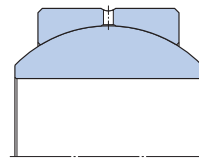
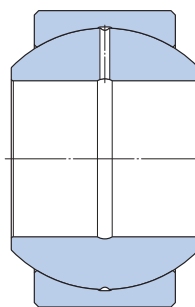
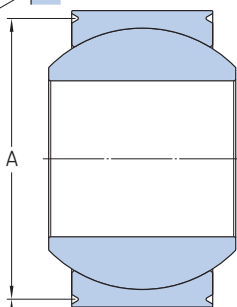
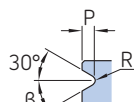
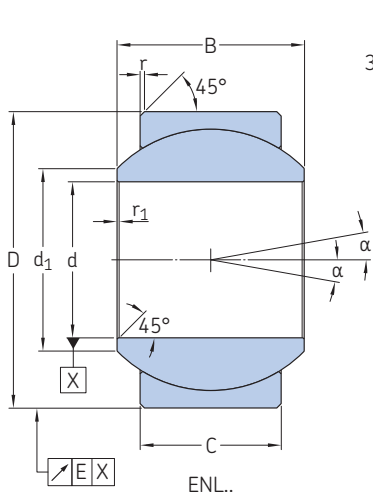

d	β	E
in/mm	°	in/mm
0.1900/ 0.2500	20	0.003
4,826/ 6,35		0,076
0.3125/ 7,938	30	0.003
0.3750/ 2.0000	30	0.005
9,525/ 50,8		0,127

2.14



Dimensions

Nominal bore code	Dash number multiples of 1/16 inch	Dimensions d	Δdmp	Δds	D	ΔDmp	ΔDs	C	B
–	–	in/mm	–	–	–	–	–	+0.005/0 +0.127/0	0/–0.002 0/–0.051
4,83	03	0.1900 4,826	0/–0.0005 0/–0.0127	0/–0.0005 0/–0.0127	0.6250 15,875	0/–0.0003 0/–0.008	0/–0.0005 0/–0.0127	0.327 8,306	0.437 11,100
6,35	04	0.2500 6,350	0/–0.0005 0/–0.0127	0/–0.0005 0/–0.0127	0.6250 15,875	0/–0.0003 0/–0.008	0/–0.0005 0/–0.0127	0.327 8,306	0.437 11,100
7,94	05	0.3125 7,938	0/–0.0005 0/–0.0127	0/–0.0005 0/–0.0127	0.6875 17,462	0/–0.0003 0/–0.008	0/–0.0005 0/–0.0127	0.317 8,052	0.437 11,100
9,52	06	0.3750 9,525	0/–0.0005 0/–0.0127	0/–0.0005 0/–0.0127	0.8125 20,638	0/–0.0004 0/–0.009	0/–0.0005 0/–0.0127	0.405 10,287	0.500 12,700
11,11	07	0.4375 11,113	0/–0.0005 0/–0.0127	0/–0.0005 0/–0.0127	0.9375 23,812	0/–0.0004 0/–0.009	0/–0.0005 0/–0.0127	0.442 11,227	0.562 14,275
11,11..DS	07A	0.4375 11,113	0/–0.0005 0/–0.0127	0/–0.0005 0/–0.0127	0.9062 23,017	0/–0.0004 0/–0.009	0/–0.0005 0/–0.0127	0.442 11,227	0.562 14,275
12,7	08	0.5000 12,700	0/–0.0005 0/–0.0127	0/–0.0005 0/–0.0127	1.0000 25,400	0/–0.0004 0/–0.009	0/–0.0005 0/–0.0127	0.505 12,827	0.625 15,875
14,29	09	0.5625 14,288	0/–0.0005 0/–0.0127	0/–0.0005 0/–0.0127	1.1250 28,575	0/–0.0004 0/–0.009	0/–0.0005 0/–0.0127	0.536 13,614	0.687 17,450

Dimensions cont.

Nominal bore code	Dash number multiples of 1/16 inch	Dimensions d1	r1	r	A	P	R	α ⁷⁾	Mass ≈
–	–	in/mm	±0.005 ±0.127	+0.010/0 +0.254/0	0/–0.008 0/–0.203	0/–0.010 0/–0.250	–	°	lb/g
4,83	03	0.300 7,62	0.010 0,254	0.015 0,381	0.563 14,300	0.025 0,640	0.005/0.010 0,127/0,254	16	0.03 13
6,35	04	0.300 7,62	0.010 0,254	0.015 0,381	0.563 14,300	0.025 0,640	0.005/0.010 0,127/0,254	16	0.03 12
7,94	05	0.360 9,14	0.010 0,254	0.015 0,381	0.625 15,875	0.025 0,640	0.005/0.010 0,127/0,254	16	0.03 13
9,52	06	0.466 11,84	0.010 0,254	0.015 0,381	0.712 18,085	0.035 0,890	0.010/0.017 0,254/0,432	10	0.05 23
11,11	07	0.537 13,64	0.010 0,254	0.020 0,508	0.837 21,260	0.035 0,890	0.010/0.017 0,254/0,432	11	0.07 33
11,11..DS	07A	0.537 13,64	0.010 0,254	–	0.808 20,520	0.035 0,890	0.010/0.017 0,254/0,432	11	0.07 30
12,7	08	0.607 15,42	0.010 0,254	0.020 0,508	0.900 22,860	0.035 0,890	0.010/0.017 0,254/0,432	10	0.09 40
14,29	09	0.721 18,31	0.010 0,254	0.020 0,508	1.025 26,035	0.035 0,890	0.010/0.017 0,254/0,432	11	0.12 56



Designation system

Examples:	ZENLS12,7RXTT-2CP6RP01	Z	ENL	S	12,7	R	X	TT	-2	CP6	RP01
	ENLC11,11RDSPPCP109										
Surface treatment of outer ring											
No code	Not plated										
Z	Cadmium plated external dimensions										
SZ ¹⁾	Zinc-nickel plated external dimensions										
Basic designation											
Lubrication grooves											
No code	Without lubrication groove										
S	Lubrication by inner ring										
C ³⁾	Lubrication by outer ring										
Y ¹⁾	Lubrication by inner and outer ring										
Bore code											
Chamfer and groove											
No code ²⁾	Chamfered outer ring										
R	Grooved outer ring										
Clearances											
No code	Standard clearances										
X	Reduced clearances										
Shield and seal											
No code	No shield and seal										
TT ^{1) 4)}	Sealed										
PP ^{1) 4)}	shielded										
Lubricant											
No code	Grease G354										
-2	Grease G395										
Surface treatment of inner ring											
No code	Passivated inner ring										
CP6 ¹⁾	Chromium plated sphere										
CP109 ¹⁾	XCR plating on sphere (chromium 6 free replacement to chromium plating)										
Oversize											
No code	Standard outer diameter size										
RP01 ¹⁾	0.010 in/0,254 mm oversized outer diameter										
RP02 ¹⁾	0.020 in/0,508 mm oversized outer diameter										

¹⁾ SKF option

²⁾ SKF option for bore code 11,11DS

³⁾ In the outer ring sphere, central lubrication groove only for $d \leq 7,94$

⁴⁾ Only available for $d \geq 7,94$

Loads and clearance

Nominal bore code	Dash number multiples of 1/16 inch	Static limit loads ⁶⁾		Standard clearances		Reduced clearances	
		Radial C_s	Axial C_a ⁵⁾	Radial	Axial max	Radial	Axial max
		lbf/kN		in/ μ m			
4,83	03	12 150	5 175	0.0004/0.0012	0.0047	0.0001/0.0004	0.0014
		54	23	10/30	120	2/10	35
6,35	04	13 725	5 850	0.0004/0.0012	0.0047	0.0001/0.0004	0.0014
		61	26	10/30	120	2/10	35
7,94	05	14 175	5 400	0.0004/0.0012	0.0047	0.0001/0.0004	0.0014
		63	24	10/30	120	2/10	35
9,52	06	21 375	8 325	0.0004/0.0012	0.0047	0.0001/0.0004	0.0014
		95	37	10/30	120	2/10	35
11,11	07	27 000	10 575	0.0004/0.0012	0.0047	0.0001/0.0004	0.0014
		120	47	10/30	120	2/10	35
11,11..DS	07A	27 000	10 575	0.0004/0.0012	0.0047	0.0001/0.0004	0.0014
		120	47	10/30	120	2/10	35
12,7	08	35 550	13 950	0.0004/0.0020	0.0090	0.0001/0.0004	0.0014
		158	62	10/50	229	2/10	35
14,29	09	43 875	16 200	0.0004/0.0020	0.0090	0.0001/0.0005	0.0016
		195	72	10/50	229	3/12	40

⁵⁾ These values can be limited by the unstaking load (contact SKF for more information)

⁶⁾ Loads are valid for the spherical plain bearings without lubrication groove. For other bearings, refer to page 134

⁷⁾ Values are given for non protected bearings. For sealed and shielded bearings, refer to page 140

2.14 Metal-to-metal swaged wide (inch dimensions)

ENL.. bore code 15,87 to 50,8

Technical specification	EN 2337
Product standards	EN 4265 (Not plated) EN 4266 (Cadmium plated external dimensions)
Standard materials	Corrosion-resistant steel inner ring and outer ring

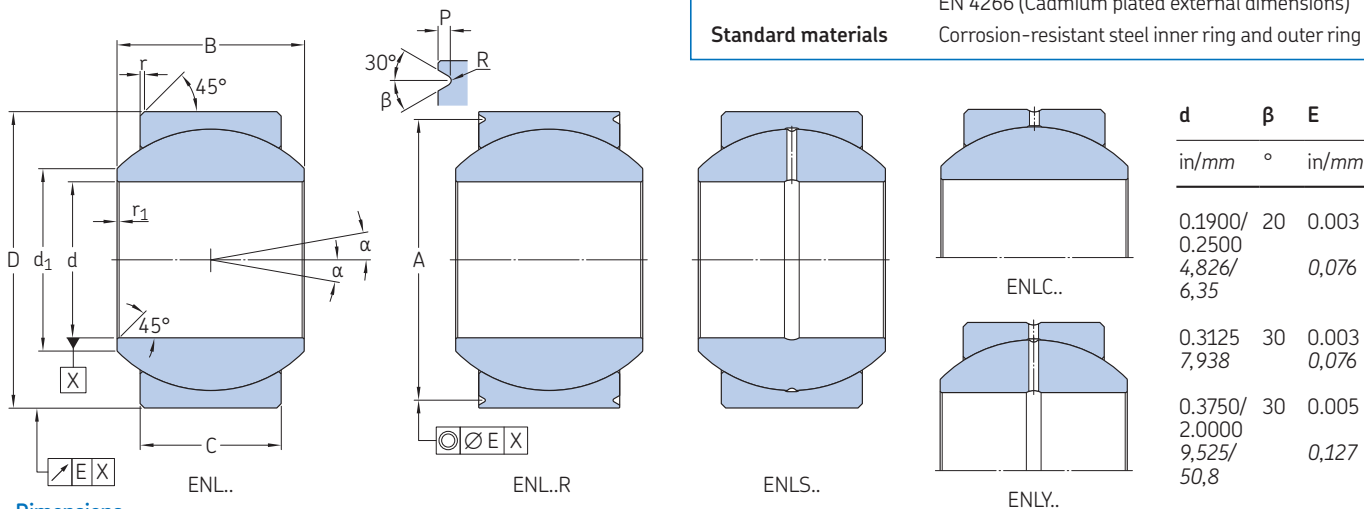

2.14

Dimensions

Nominal bore code	Dash number multiples of 1/16 inch	Dimensions d	Δdmp	Δds	D	ΔDmp	ΔDs	C	B
								+0.005/0 +0,127/0	0/-0.002 0/-0,051
		in/mm							
15,87	10	0.6250 15,875	0/-0.0005 0/-0,0127	0/-0.0005 0/-0,0127	1.1875 30,163	0/-0.0004 0/-0,009	0/-0.0005 0/-0,0127	0.567 14,400	0.750 19,050
19,05	12	0.7500 19,050	0/-0.0005 0/-0,0127	0/-0.0005 0/-0,0127	1.3750 34,925	0/-0.0004 0/-0,011	0/-0.0005 0/-0,0127	0.630 16,002	0.875 22,225
22,22	14	0.8750 22,225	0/-0.0005 0/-0,0127	0/-0.0005 0/-0,0127	1.6250 41,275	0/-0.0004 0/-0,011	0/-0.0005 0/-0,0127	0.755 19,177	0.875 22,225
25,4	16	1.0000 25,400	0/-0.0005 0/-0,0127	+0.0001/-0.0006 +0,0025/-0,0152	2.1250 53,975	0/-0.0005 0/-0,013	+0.0001/-0.0006 +0,0025/-0,0152	1.005 25,527	1.375 34,925
31,75	20	1.2500 31,750	0/-0.0005 0/-0,0127	+0.0001/-0.0006 +0,0025/-0,0152	2.3750 60,325	0/-0.0005 0/-0,013	+0.0001/-0.0006 +0,0025/-0,0152	1.130 28,702	1.500 38,100
38,10	24	1.5000 38,100	0/-0.0005 0/-0,0127	+0.0001/-0.0006 +0,0025/-0,0152	2.6875 68,260	0/-0.0005 0/-0,013	+0.0001/-0.0006 +0,0025/-0,0152	1.223 31,064	1.687 42,850
44,45	28	1.7500 44,450	0/-0.0005 0/-0,0127	+0.0001/-0.0006 +0,0025/-0,0152	3.0000 76,200	0/-0.0005 0/-0,013	+0.0001/-0.0006 +0,0025/-0,0152	1.317 33,452	1.812 46,020
50,8	32	2.0000 50,800	0/-0.0005 0/-0,0127	+0.0001/-0.0006 +0,0025/-0,0152	3.2500 82,550	0/-0.0005 0/-0,013	+0.0001/-0.0006 +0,0025/-0,0152	1.380 35,050	1.937 49,190

Dimensions cont.

Nominal bore code	Dash number multiples of 1/16 inch	Dimensions d1	r1	r	A	P	R	α ⁷⁾	Mass ≈	
			±0.005 ±0,127	+0.010/0 +0,254/0	0/-0.008 0/-0,203	0/-0.010 0/-0,250				
		in/mm							°	lb/g
15,87	10	0.747 18,97	0.010 0,254	0.020 0,508	1.087 27,610	0.035 0,890	0.010/0.017 0.254/0.432	12	0.14 63	
19,05	12	0.845 21,46	0.010 0,254	0.030 0,762	1.251 31,775	0.055 1,400	0.010/0.017 0.254/0.432	14	0.20 92	
22,22	14	0.995 25,27	0.010 0,254	0.030 0,762	1.501 38,125	0.055 1,400	0.010/0.017 0.254/0.432	6	0.32 146	
25,4	16	1.269 32,23	0.010 0,254	0.030 0,762	2.001 50,825	0.055 1,400	0.010/0.017 0.254/0.432	15	0.86 392	
31,75	20	1.462 37,15	0.010 0,254	0.030 0,762	2.251 57,180	0.055 1,400	0.010/0.017 0.254/0.432	13	1.10 499	
38,10	24	1.697 43,10	0.010 0,254	0.030 0,762	2.563 65,100	0.055 1,400	0.010/0.017 0.254/0.432	14	1.47 668	
44,45	28	1.965 49,90	0.010 0,254	0.030 0,762	2.876 73,050	0.055 1,400	0.010/0.017 0.254/0.432	13	1.89 859	
50,8	32	2.209 56,10	0.010 0,254	0.030 0,762	3.124 79,350	0.055 1,400	0.010/0.017 0.254/0.432	13	2.22 1 005	



Designation system

Examples:	ZENLS12,7RXTT-2CP6RP01	Z	ENL	S	12,7	R	X	TT	-2	CP6	RP01
	ENLC11,11RDSPPCP109										
Surface treatment of outer ring											
No code	Not plated										
Z	Cadmium plated external dimensions										
SZ ¹⁾	Zinc-nickel plated external dimensions										
Basic designation											
Lubrication grooves											
No code	Without lubrication groove										
S	Lubrication by inner ring										
C ³⁾	Lubrication by outer ring										
Y ¹⁾	Lubrication by inner and outer ring										
Bore code											
Chamfer and groove											
No code ²⁾	Chamfered outer ring										
R	Grooved outer ring										
Clearances											
No code	Standard clearances										
X	Reduced clearances										
Shield and seal											
No code	No shield and seal										
TT ^{1) 4)}	Sealed										
PP ^{1) 4)}	shielded										
Lubricant											
No code	Grease G354										
-2	Grease G395										
Surface treatment of inner ring											
No code	Passivated inner ring										
CP6 ¹⁾	Chromium plated sphere										
CP109 ¹⁾	XCR plating on sphere (chromium 6 free replacement to chromium plating)										
Over-size											
No code	Standard outer diameter size										
RP01 ¹⁾	0.010 in/0,254 mm oversized outer diameter										
RP02 ¹⁾	0.020 in/0,508 mm oversized outer diameter										

1) SKF option

2) SKF option for bore code 11,11DS

3) In the outer ring sphere, central lubrication groove only for $d \leq 7,94$

4) Only available for $d \geq 7,94$

Loads and clearance

Nominal bore code	Dash number multiples of 1/16 inch	Static limit loads ⁶⁾		Standard clearances		Reduced clearances	
		Radial C_s	Axial C_a ⁵⁾	Radial	Axial max	Radial	Axial max
		lbf/kN		in/ μ m			
15,87	10	49 500	17 775	0.0004/0.0020	0.0090	0.0001/0.0005	0.0016
		220	79	10/50	229	3/12	40
19,05	12	64 125	20 925	0.0004/0.0020	0.0090	0.0015/0.0006	0.0020
		285	93	10/50	229	4/15	50
22,22	14	83 250	31 725	0.0004/0.0020	0.0090	0.0015/0.0006	0.0020
		370	141	10/50	229	4/15	50
25,4	16	158 625	59 625	0.0004/0.0020	0.0090	0.0015/0.0006	0.0020
		706	265	10/50	229	4/15	50
31,75	20	200 250	76 500	0.0004/0.0020	0.0090	0.0015/0.0006	0.0020
		891	340	10/50	229	4/15	50
38,10	24	247 500	92 250	0.0004/0.0020	0.0090	0.0015/0.0006	0.0020
		1 101	410	10/50	229	4/15	50
44,45	28	299 250	108 000	0.0004/0.0020	0.0090	0.0015/0.0006	0.0020
		1 331	480	10/50	229	4/15	50
50,8	32	344 250	117 000	0.0004/0.0020	0.0090	0.0002/0.0008	0.0024
		1 531	520	10/50	229	5/20	60

5) These values can be limited by the unstaking load (contact SKF for more information)

6) Loads are valid for the spherical plain bearings without lubrication groove. For other bearings, refer to page 134

7) Values are given for non protected bearings. For sealed and shielded bearings, refer to page 140

2.15 Metal-to-metal swaged high misalignment (inch dimensions)

MT.. bore code 4,83 to 12,7

Technical specification –
Product standards –

d	β	E
in/mm	°	in/mm
0.1900/0.4375 4,826/11,113	20	0.005 0,127
0.5000/1.2500 12,7/31,75	30	0.005 0,127

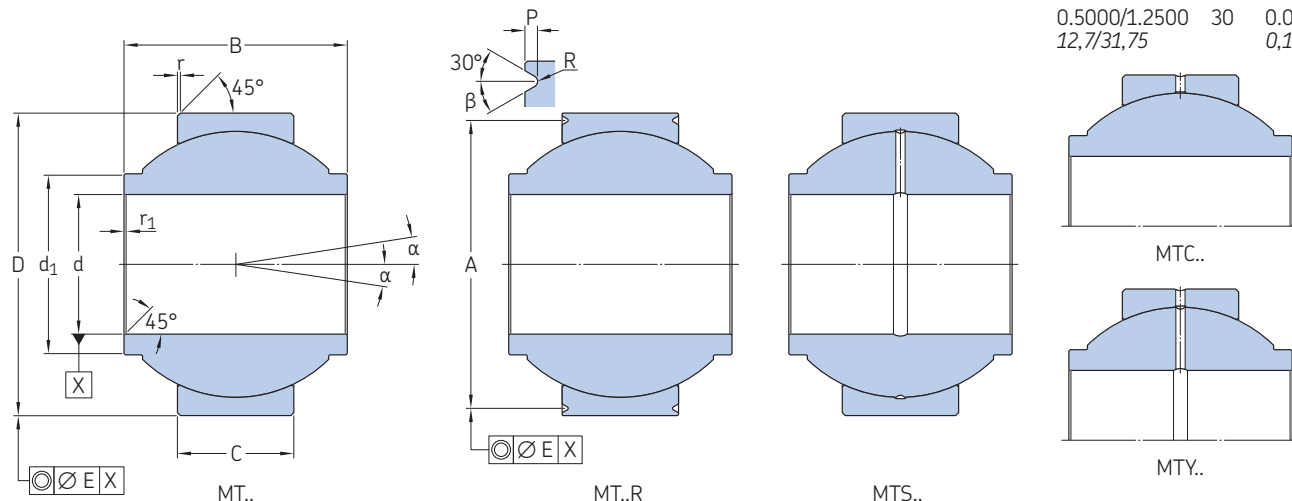

Dimensions

Nominal bore code	Dash number multiples of 1/16 inch	Dimensions		C	B	d ₁ ≈	r ₁ +0.012/-0 +0,230/-0	r +0.015/0 +0,381/-0	A +0.010/0 +0,254/0	P 0/-0.254 0/-0,010	
		d	D								
		in/mm									
4,83	03	0.1900	0.5625	0.205	0.500	0.315	0.004	0.020	0.502	0.030	
		4,826	14,288	5,207	12,700	8,000	0,100	0,508	12,751	0,762	
6,35	04	0.2500	0.7400	0.250	0.593	0.386	0.004	0.020	0.669	0.030	
		6,350	18,796	6,350	15,062	9,800	0,100	0,508	17,000	0,762	
7,94	05	0.3125	0.9060	0.340	0.813	0.512	0.004	0.020	0.831	0.030	
		7,938	23,012	8,636	20,650	13,000	0,100	0,508	21,100	0,762	
9,52	06	0.3750	0.9060	0.340	0.813	0.532	0.004	0.020	0.831	0.030	
		9,525	23,012	8,636	20,650	13,500	0,100	0,508	21,100	0,762	
11,11	07	0.4375	1.0000	0.340	0.875	0.620	0.004	0.020	0.925	0.030	
		11,113	25,400	8,636	22,225	15,750	0,100	0,508	23,500	0,762	
12,7	08	0.5000	1.1250	0.396	0.937	0.728	0.004	0.020	1.047	0.030	
		12,700	28,575	10,058	23,799	18,480	0,100	0,508	26,600	0,762	

Dimensions cont., loads and clearance

Nominal bore code	Dash number multiples of 1/16 inch	Dimensions		Mass ≈	Static limit loads ²⁾		Axial clearance	
		R	α ³⁾		Radial C _s	Axial C _a ¹⁾	Reduced	Standard
		in/mm		lb/g	lbf/kN		in/μm	
4,83	03	0.005/0.010	15	0.02	3 642	899	0.0002/0.0020	0.0020/0.0040
		0.127/0.254		9	16,2	4,0	5/50	50/100
6,35	04	0.005/0.010	24	0.04	6 924	517	0.0002/0.0020	0.0020/0.0040
		0.127/0.254		18	30,8	2,3	5/50	50/100
7,94	05	0.005/0.010	23	0.07	12 544	1 304	0.0002/0.0020	0.0020/0.0040
		0.127/0.254		32	55,8	5,8	5/50	50/100
9,52	06	0.005/0.010	22	0.07	12 544	1 304	0.0002/0.0020	0.0020/0.0040
		0.127/0.254		32	55,8	5,8	5/50	50/100
11,11	07	0.005/0.010	22	0.10	13 286	1 394	0.0002/0.0020	0.0020/0.0040
		0.127/0.254		45	59,1	6,2	5/50	50/100
12,7	08	0.005/0.010	20	0.16	18 906	2 360	0.0002/0.0020	0.0020/0.0040
		0.127/0.254		73	84,1	10,5	5/50	50/100

¹⁾ These values can be limited by the unstaking load (contact SKF for more information)

²⁾ Loads are valid for the steel/steel spherical plain bearings without lubrication groove. For other bearings, refer to page 134

³⁾ Values are given for non protected bearings. For sealed and shielded bearings, refer to page 140



Designation system

Examples: ZWQMTS12,7RXTT-2CP6RP01
QMT25,4PPCP109

Surface treatment of outer ring

No code Not plated
Z Cadmium plated external dimensions
SZ Zinc-nickel plated external dimensions

Material code **Inner ring material** **External ring material**
W Corrosion-resistant steel Corrosion-resistant steel
Q Bronze beryllium Corrosion-resistant steel
WQ Corrosion-resistant steel Bronze aluminium

Basic designation

Lubrication grooves

No code Without lubrication groove
S Lubrication by inner ring
C³⁾ Lubrication by outer ring
Y Lubrication by inner and outer ring

Bore code

Chamfer and groove

No code Chamfered outer ring
R Grooved outer ring

Axial clearance

No code Standard axial clearance
X Reduced axial clearance

Shield and seal

No code No shield and seal
TT⁴⁾ Sealed
PP⁴⁾ Shielded

Lubricant

No code Grease G354
-2 Grease G395

Surface treatment of inner ring

No code Not plated
CP6²⁾ Chromium plated sphere
CP109²⁾ XCR plating on sphere (chromium 6 free replacement to chromium plating)
CP55²⁾ Passivated corrosion-resistant steel inner ring

Oversize

No code Standard outer diameter size
RP01 0.010 in/0,254 mm oversized outer diameter
RP02 0.020 in/0,508 mm oversized outer diameter

²⁾ Available only for inner ring in corrosion-resistant steel material

³⁾ In the outer ring sphere, central lubrication groove only for $d \leq 7,94$

⁴⁾ Only available for $d \geq 7,94$

2.15 Metal-to-metal swaged high misalignment (inch dimensions)

MT.. bore code 15,87 to 31,75

Technical specification –
Product standards –

d	β	E
in/mm	°	in/mm
0.1900/0.4375 4,826/11,113	20	0.005 0,127
0.5000/1.2500 12,7/31,75	30	0.005 0,127

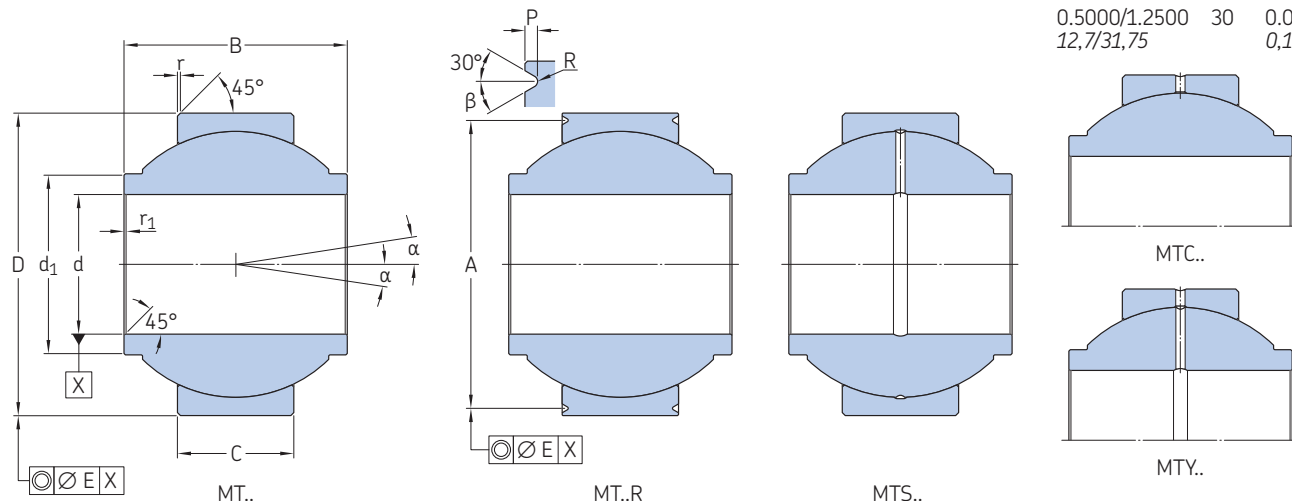

Dimensions

Nominal bore code	Dash number multiples of 1/16 inch	Dimensions								
		d	D	C	B	d ₁	r ₁	r	A	P
		0/-0.0005 0/-0,0127	0/-0.0005 0/-0,0127	±0.010 ±0,254	0/-0.005 0/-0,127	≈	+0.012/-0 +0,230/-0	+0.015/0 +0,381/-0	+0.010/0 +0,254/0	0/-0.254 0/-0,010
– in/mm										
15,87	10	0.6250 15,875	1.3750 34,925	0.562 14,275	1.200 30,480	0.857 21,770	0.004 0,100	0.020 0,508	1.268 32,200	0.040 1,016
19,05	12	0.7500 19,050	1.5625 39,688	0.615 15,621	1.280 32,512	0.963 24,450	0.004 0,100	0.020 0,508	1.437 36,500	0.060 1,524
22,22	14	0.8750 22,225	1.7500 44,450	0.620 15,748	1.400 35,560	1.122 28,490	0.004 0,100	0.020 0,508	1.624 41,250	0.060 1,524
25,4	16	1.0000 25,400	2.1250 53,975	0.830 21,082	1.875 47,625	1.272 32,320	0.004 0,100	0.020 0,508	2.003 50,876	0.060 1,524
31,75	20	1.2500 31,750	2.5000 63,500	1.000 25,400	1.875 47,625	1.523 38,700	0.004 0,100	0.020 0,508	2.370 60,200	0.060 1,524

Dimensions cont., loads and clearance

Nominal bore code	Dash number multiples of 1/16 inch	Dimensions		Mass ≈	Static limit loads ²⁾		Axial clearance	
		R	$\alpha^3)$		Radial C _s	Axial C _a ¹⁾	Reduced	Standard
–		in/mm	°	lb/g	lbf/kN	in/ μ m		
15,87	10	0.010/0.020 0,254/0,508	20	0.25 114	34 080 151,6	5 553 24,7	0.0002/0.0020 5/50	0.0020/0.0040 50/100
19,05	12	0.010/0.020 0,254/0,508	19	0.32 145	51 457 228,9	6 362 28,3	0.0002/0.0020 5/50	0.0020/0.0040 50/100
22,22	14	0.010/0.020 0,254/0,508	19	0.43 195	61 708 274,5	6 452 28,7	0.0002/0.0024 5/60	0.0024/0.0047 60/120
25,4	16	0.010/0.020 0,254/0,508	21	0.81 367	84 053 373,9	12 206 54,3	0.0002/0.0024 5/60	0.0024/0.0047 60/120
31,75	20	0.010/0.020 0,254/0,508	21	1.11 504	119 301 530,7	19 355 86,1	0.0002/0.0024 5/60	0.0024/0.0047 60/120

1) These values can be limited by the unstaking load (contact SKF for more information)

2) Loads are valid for the steel/steel spherical plain bearings without lubrication groove. For other bearings, refer to page 134

3) Values are given for non protected bearings. For sealed and shielded bearings, refer to page 140



Designation system

Examples: ZWQMTS12,7RXTT-2CP6RP01
QMT25,4PPCP109

Surface treatment of outer ring

No code Not plated
Z Cadmium plated external dimensions
SZ Zinc-nickel plated external dimensions

Material code **Inner ring material** **External ring material**
W Corrosion-resistant steel Corrosion-resistant steel
Q Bronze beryllium Corrosion-resistant steel
WQ Corrosion-resistant steel Bronze aluminium

Basic designation

Lubrication grooves

No code Without lubrication groove
S Lubrication by inner ring
C³⁾ Lubrication by outer ring
Y Lubrication by inner and outer ring

Bore code

Chamfer and groove

No code Chamfered outer ring
R Grooved outer ring

Axial clearance

No code Standard axial clearance
X Reduced axial clearance

Shield and seal

No code No shield and seal
TT⁴⁾ Sealed
PP⁴⁾ Shielded

Lubricant

No code Grease G354
-2 Grease G395

Surface treatment of inner ring

No code Not plated
CP6²⁾ Chromium plated sphere
CP109²⁾ XCR plating on sphere (chromium 6 free replacement to chromium plating)
CP55²⁾ Passivated corrosion-resistant steel inner ring

Oversize

No code Standard outer diameter size
RP01 0.010 in/0,254 mm oversized outer diameter
RP02 0.020 in/0,508 mm oversized outer diameter

²⁾ Available only for inner ring in corrosion-resistant steel material

³⁾ In the outer ring sphere, central lubrication groove only for $d \leq 7,94$

⁴⁾ Only available for $d \geq 7,94$

2.16 Metal-to-metal swaged (inch dimensions)

QXMB.. bore code 6,35 to 19,05

Technical specification AS 81936

Product standards

AS 81936/1 (Grooved outer ring)
AS 81936/2 (Chamfered outer ring)

Materials

Inner ring: Bronze beryllium
External ring: Corrosion-resistant steel

Lubricant

Grease G395

d	β	E
in/mm	°	in/mm
0.2500 6,35	20	0.005 0,127
≥ 0.3125 ≥ 7,938	30	0.005 0,127

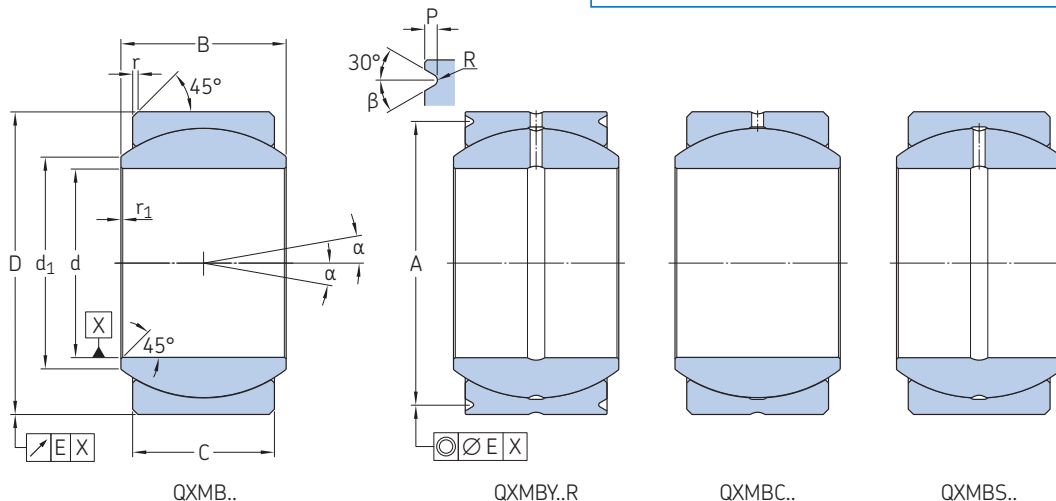

Dimensions

Nominal bore code	Dash number multiples of 1/16 inch	Dimensions								
		d	D	C	B	d ₁ ≈	r ₁	r	A	P
		0/-0,0005 0/-0,0127	0/-0,0005 0/-0,0127	0/-0,005 0/-0,127	0/-0,005 0/-0,127		+0,010/-0 +0,254/-0	+0,030/-0 +0,762/-0	+0/-0,010 +0/-0,254	0/-0,015 0/-0,380
in/mm										
6,35	04	0.2500 6,350	0.6562 16,667	0.250 6,350	0.343 8,712	0.357 9,068	0.005 0,127	0.010 0,254	0.596 15,138	0.030 0,762
7,94	05	0.3125 7,938	0.7500 19,050	0.281 7,137	0.375 9,525	0.413 10,490	0.005 0,127	0.010 0,254	0.652 16,561	0.040 1,016
9,52	06	0.3750 9,525	0.8125 20,638	0.312 7,925	0.406 10,312	0.509 12,923	0.005 0,127	0.010 0,254	0.714 18,136	0.040 1,016
11,11	07	0.4375 11,113	0.9062 23,017	0.343 8,712	0.437 11,100	0.563 14,300	0.005 0,127	0.010 0,254	0.808 20,523	0.040 1,016
12,7	08	0.5000 12,700	1.0000 25,400	0.390 9,906	0.500 12,700	0.634 16,104	0.005 0,127	0.010 0,254	0.878 22,301	0.060 1,524
14,29	09	0.5625 14,288	1.0937 27,780	0.437 11,100	0.562 14,275	0.664 16,866	0.005 0,127	0.010 0,254	0.972 24,689	0.060 1,524
15,87	10	0.6250 15,875	1.1875 30,163	0.500 12,700	0.625 15,875	0.732 18,593	0.005 0,127	0.010 0,254	1.065 27,051	0.060 1,524
19,05	12	0.7500 19,050	1.4375 36,513	0.593 15,062	0.750 19,050	0.913 23,190	0.005 0,127	0.010 0,254	1.315 33,401	0.060 1,524



Designation system

Examples: ZQXMB12,7RTTRP01
QXMB25,4PP

Z QXMB C 12,7 R TT RP01

Surface treatment of outer ring

No code Not plated
Z¹⁾ Cadmium plated external dimensions
SZ¹⁾ Zinc-nickel plated external dimensions

Basic designation

Lubrication grooves

No code¹⁾ Without lubrication groove
S¹⁾ Lubrication by inner ring
C²⁾ Lubrication by outer ring
Y Lubrication by inner and outer ring

Bore code

Chamfer and groove

No code Chamfered outer ring
R Grooved outer ring

Shield and seal

No code No shield and seal
TT^{1), 3)} Sealed
PP^{1), 3)} Shielded

Oversize

No code Standard outer diameter size
RP01 0.010 in/0,254 mm oversized outer diameter
RP02 0.020 in/0,508 mm oversized outer diameter

¹⁾ SKF option

²⁾ In the outer ring sphere, central lubrication groove only for $d \leq 7,94$

³⁾ Only available for $d \geq 7,94$

Dimensions cont., loads and clearance

Nominal bore code	Dash number multiples of 1/16 inch	Dimensions		$\alpha^{(4)}$	Mass =	Static limit loads		Dynamic loads		Clearances max	
		R				Radial C_s	Axial ⁽¹⁾ C_a	Mode I ⁽²⁾	Mode II ⁽³⁾	Radial	Axial
		in/mm		°	lb/g	lbf/kN			in/ μ m		
6,35	04	0.005/0.010		12	0.03	6 330	1 930	2 570	5 000	0.001	0.005
		0,127/0,254			14	28,16	8,59	11,43	22,24	25	127
7,94	05	0.010/0.020		11	0.04	8 460	2 450	3 520	6 300	0.001	0.005
		0,127/0,254			18	37,63	10,90	15,66	28,02	25	127
9,52	06	0.010/0.020		9	0.05	11 400	3 090	4 570	8 200	0.001	0.005
		0,254/0,508			22	50,71	13,75	20,33	36,48	25	127
11,11	07	0.010/0.020		8	0.06	14 800	3 740	5 750	9 900	0.001	0.005
		0,254/0,508			27	65,83	16,64	25,58	44,04	25	127
12,7	08	0.010/0.020		8	0.08	20 400	4 860	7 500	12 650	0.001	0.005
		0,254/0,508			36	90,74	21,62	33,36	56,27	25	127
14,29	09	0.010/0.020		8	0.11	26 700	6 100	9 500	15 300	0.001	0.005
		0,254/0,508			50	118,77	27,13	42,26	68,06	25	127
15,87	10	0.010/0.020		8	0.14	33 100	8 080	11 750	19 300	0.001	0.005
		0,254/0,508			64	147,24	35,94	52,27	85,85	25	127
19,05	12	0.010/0.020		8	0.24	50 000	11 440	16 900	28 200	0.001	0.005
		0,254/0,508			109	222,41	50,89	75,17	125,44	25	127

¹⁾ These values can be limited by the unstaking load (contact SKF for more information)

²⁾ Load fixed with respect to the outer ring

³⁾ Load fixed with respect to the inner ring

⁴⁾ Values are given for non protected bearings. For sealed and shielded bearings, refer to page 140

2.16 Metal-to-metal swaged (inch dimensions)

QXMB.. bore code 20,64 to 38,10

Technical specification AS 81936

Product standards

AS 81936/1 (Grooved outer ring)
AS 81936/2 (Chamfered outer ring)

Materials

Inner ring: Bronze beryllium
External ring: Corrosion-resistant steel

Lubricant

Grease G395

d	β	E
in/mm	°	in/mm
0.2500 6,35	20	0.005 0,127
≥ 0.3125 ≥ 7,938	30	0.005 0,127

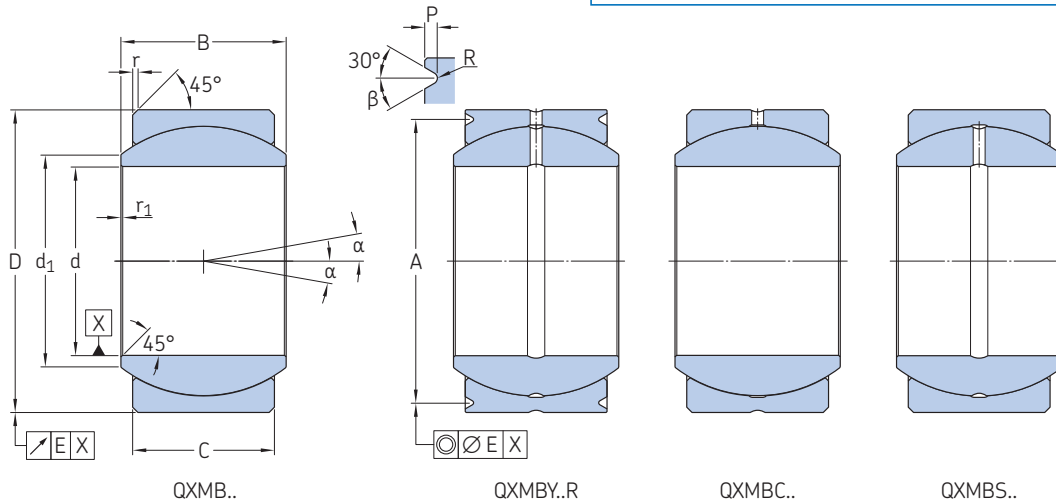

Dimensions

Nominal bore code	Dash number multiples of 1/16 inch	Dimensions								
		d	D	C	B	d ₁	r ₁	r	A	P
		0/-0,0005 0/-0,0127	0/-0,0005 0/-0,0127	0/-0,005 0/-0,127	0/-0,005 0/-0,127	≈	+0,010/-0 +0,254/-0	+0,030/-0 +0,762/-0	+0/-0,010 +0/-0,254	0/-0,015 0/-0,380
-		in/mm								
20,64	13	0.8125	1.5625	0.650	0.812	0.984	0.005	0.010	1.440	0.060
		20,638	39,688	16,510	20,625	24,994	0,127	0,254	36,576	1,524
22,22	14	0.8750	1.6562	0.703	0.875	1.054	0.005	0.010	1.534	0.060
		22,225	42,067	17,856	22,225	26,772	0,127	0,254	38,964	1,524
25,4	16	1.0000	1.8750	0.797	1.000	1.193	0.005	0.010	1.753	0.060
		25,400	47,625	20,244	25,400	30,302	0,127	0,254	44,653	1,524
28,57	18	1.1250	2.1250	0.900	1.125	1.334	0.005	0.010	2.003	0.060
		28,575	53,975	22,860	28,575	33,884	0,127	0,254	50,876	1,524
31,75	20	1.2500	2.3125	1.000	1.250	1.473	0.005	0.010	2.190	0.060
		31,750	58,737	25,400	31,750	37,414	0,127	0,254	55,626	1,524
34,92	22	1.3750	2.5625	1.100	1.375	1.654	0.005	0.010	2.440	0.060
		34,925	65,088	27,940	34,925	42,012	0,127	0,254	61,976	1,524
38,10	24	1.5000	2.8125	1.200	1.500	1.794	0.005	0.010	2.690	0.060
		38,100	71,437	30,480	38,100	45,568	0,127	0,254	68,326	1,524



Designation system

Examples: ZQXMB12,7RTTRP01
QXMB25,4PP

Z QXMB C 12,7 R TT RP01

Surface treatment of outer ring

No code Not plated
Z¹⁾ Cadmium plated external dimensions
SZ¹⁾ Zinc-nickel plated external dimensions

Basic designation

Lubrication grooves

No code¹⁾ Without lubrication groove
S¹⁾ Lubrication by inner ring
C²⁾ Lubrication by outer ring
Y Lubrication by inner and outer ring

Bore code

Chamfer and groove

No code Chamfered outer ring
R Grooved outer ring

Shield and seal

No code No shield and seal
TT^{1), 3)} Sealed
PP^{1), 3)} Shielded

Oversize

No code Standard outer diameter size
RP01 0.010 in/0,254 mm oversized outer diameter
RP02 0.020 in/0,508 mm oversized outer diameter

¹⁾ SKF option

²⁾ In the outer ring sphere, central lubrication groove only for $d \leq 7,94$

³⁾ Only available for $d \geq 7,94$

Dimensions cont., loads and clearance

Nominal bore code	Dash number multiples of 1/16 inch	Dimensions		Mass =	Static limit loads		Dynamic loads		Clearances max	
		R	α^4		Radial C_s	Axial ¹⁾ C_a	Mode I ²⁾	Mode II ³⁾	Radial	Axial
–		in/mm	°	lb/g	lbf/kN				in/ μ m	
20,64	13	0.010/0.020	8	0.28	59 000	13 800	19 800	33 400	0.001	0.005
		0,254/0,508		127	262,45	61,39	88,07	148,57	25	127
22,22	14	0.010/0.020	8	0.37	70 300	16 160	23 000	38 700	0.001	0.005
		0,254/0,508		168	312,71	71,88	102,31	172,15	25	127
25,4	16	0.010/0.020	8	0.53	77 700	20 850	30 000	49 800	0.001	0.005
		0,254/0,508		240	345,63	92,75	133,45	221,52	25	127
28,57	18	0.010/0.020	8	0.71	121 500	26 740	38 000	63 000	0.001	0.005
		0,254/0,508		321	540,46	118,95	169,03	280,24	25	127
31,75	20	0.010/0.020	8	1.00	152 000	33 065	46 900	77 500	0.001	0.005
		0,254/0,508		454	676,13	147,08	208,62	344,74	25	127
34,92	22	0.010/0.020	8	1.26	186 000	40 120	56 900	95 000	0.001	0.005
		0,254/0,508		570	827,37	178,46	253,10	422,58	25	127
38,10	24	0.010/0.020	8	1.79	224 000	47 820	67 500	112 500	0.001	0.005
		0,254/0,508		812	996,40	212,71	300,25	500,42	25	127

¹⁾ These values can be limited by the unstaking load (contact SKF for more information)

²⁾ Load fixed with respect to the outer ring

³⁾ Load fixed with respect to the inner ring

⁴⁾ Values are given for non protected bearings. For sealed and shielded bearings, refer to page 140

2.17 Metal-to-metal split (inch dimensions)

2PL.. bore code **4,83** to **15,87**

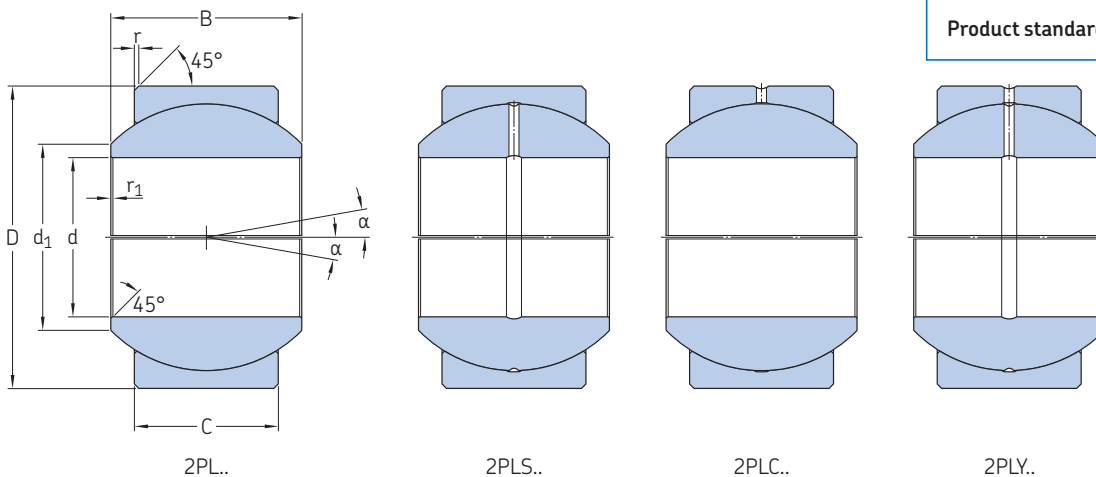

Technical specification -
Product standards -

2.17



Dimensions

Nominal bore code	Dash number multiples of 1/16 inch	Dimensions		D	C	B	d ₁ ≈	r ₁ ±0,005 ±0,127	r +0,010/0 +0,254/0	α ²⁾
		d 0/-0,0005 0/-0,0127	D 0/-0,0005 0/-0,0127							
		in/mm								
4,83	03	0.1900	0.6250	0.327	0.437	0.300	0.010	0.015	15	
		4,826	15,875	8,306	11,100	7,620	0,254	0,381		
6,35	04	0.2500	0.6250	0.327	0.437	0.300	0.010	0.015	15	
		6,350	15,875	8,306	11,100	7,620	0,254	0,381		
7,94	05	0.3125	0.6875	0.317	0.437	0.360	0.010	0.015	14	
		7,938	17,462	8,052	11,100	9,140	0,254	0,381		
9,52	06	0.3750	0.8125	0.406	0.500	0.466	0.010	0.020	8	
		9,525	20,638	10,312	12,700	11,840	0,254	0,508		
11,11	07	0.4375	0.9375	0.442	0.562	0.537	0.010	0.020	10	
		11,113	23,812	11,227	14,275	13,640	0,254	0,508		
12,7	08	0.5000	1.0000	0.505	0.625	0.607	0.010	0.020	9	
		12,700	25,400	12,827	15,875	15,420	0,254	0,508		
14,29	09	0.5625	1.1250	0.536	0.687	0.721	0.010	0.020	10	
		14,288	28,575	13,614	17,450	18,310	0,254	0,508		
15,87	10	0.6250	1.1875	0.567	0.750	0.747	0.010	0.020	12	
		15,875	30,163	14,400	19,050	18,970	0,254	0,508		

Loads and clearance

Nominal bore code	Dash number multiples of 1/16 inch	Mass ≈	Static limit loads ¹⁾		Clearance Radial
			Radial C _s	Axial C _a	
		lb/g	lbf/kN	in/μm	
4,83	03	0.03	12 150	5 175	0.0004/0.0008
		14	54	23	10/20
6,35	04	0.03	13 725	5 850	0.0004/0.0008
		14	61	26	10/20
7,94	05	0.035	14 175	5 400	0.0004/0.0008
		16	63	24	10/20
9,52	06	0.06	21 375	8 325	0.0004/0.0008
		27	95	37	10/20
11,11	07	0.08	27 000	10 575	0.0004/0.0008
		38	120	47	10/20
12,7	08	0.10	35 550	13 950	0.0004/0.0008
		45	158	62	10/20
14,29	09	0.14	43 875	16 200	0.0004/0.0012
		61	195	72	10/30
15,87	10	0.16	49 500	17 775	0.0004/0.0012
		73	220	79	10/30

¹⁾ Loads are valid for the steel/steel spherical plain bearings without lubrication groove. For other bearings, refer to page 134

²⁾ Values are given for non protected bearings. For sealed and shielded bearings, refer to page 140



Designation system

Examples: ZW2PLS12,7TT-2CP6RP01
Q2PLC25,4PPCP109

Surface treatment of outer ring

No code Not plated
Z Cadmium plated external dimensions
SZ Zinc-nickel plated external dimensions

Material code **Inner ring material** **External ring material**
W Corrosion-resistant steel Corrosion-resistant steel
Q Bronze beryllium Corrosion-resistant steel
WQ Corrosion-resistant steel Bronze aluminium

Basic designation

Lubrication grooves

No code Without lubrication groove
S Lubrication by inner ring
C²⁾ Lubrication by outer ring
Y Lubrication by inner and outer ring

Bore code

Shield and seal

No code No shield and seal
TT³⁾ Sealed
PP³⁾ Shielded

Lubricant

No code Grease G354
-2 Grease G395

Surface treatment of inner ring

No code Not plated
CP6¹⁾ Chromium plated sphere
CP109¹⁾ XCR plating on sphere (chromium 6 free replacement to chromium plating)
CP55¹⁾ Passivated corrosion-resistant steel inner ring

Oversize

No code Standard outer diameter size
RP01 0.010 in/0,254 mm oversized outer diameter
RP02 0.020 in/0,508 mm oversized outer diameter

1) Available only for inner ring in corrosion-resistant steel material
2) In the outer ring sphere, central lubrication groove only for $d \leq 7,94$
3) Only available for $d \geq 7,94$

2.17 Metal-to-metal split (inch dimensions)

2PL.. bore code 19,05 to 50,80

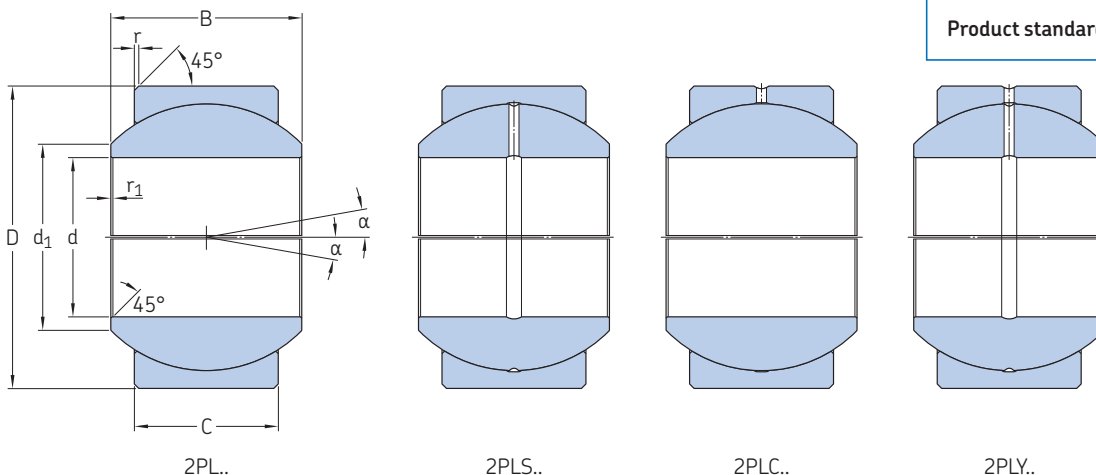

Technical specification	-
Product standards	-

2.17



Dimensions

Nominal bore code	Dash number multiples of 1/16 inch	Dimensions		D	C	B	d ₁ ≈	r ₁ ±0.005 ±0,127	r +0.010/0 +0,254/0	α ²⁾
		d	D							
		in/mm								°
19,05	12	0.7500 19,050	1.3750 34,925	0.630 16,002	0.875 22,225	0.845 21,460	0.010 0,254	0.030 0,762	13	
22,22	14	0.8750 22,225	1.6250 41,275	0.755 19,177	0.875 22,225	0.995 25,270	0.010 0,254	0.030 0,762	6	
25,4	16	1.0000 25,400	2.1250 53,975	1.005 25,527	1.375 34,925	1.269 32,230	0.010 0,254	0.030 0,762	12	
31,75	20	1.2500 31,750	2.3750 60,325	1.130 28,702	1.500 38,100	1.462 37,150	0.010 0,254	0.030 0,762	12	
38,10	24	1.5000 38,100	2.6875 68,260	1.223 31,064	1.687 42,850	1.697 43,100	0.010 0,254	0.030 0,762	13	
44,45	28	1.7500 44,450	3.0000 76,200	1.317 33,452	1.812 46,020	1.965 49,900	0.010 0,254	0.030 0,762	12	
50,80	32	2.0000 50,800	3.2500 82,550	1.380 35,050	1.937 49,190	2.209 56,100	0.010 0,254	0.030 0,762	12	

Loads and clearance

Nominal bore code	Dash number multiples of 1/16 inch	Mass ≈	Static limit loads ¹⁾		Clearance Radial
			Radial C _s	Axial C _a	
		lb/g	lbf/kN		in/μm
19,05	12	0.24 109	64 125 285	20 925 93	0.0004/0.0012 10/30
22,22	14	0.35 159	83 250 370	31 725 141	0.0004/0.0012 10/30
25,4	16	0.97 440	158 625 706	59 625 265	0.0004/0.0016 10/40
31,75	20	1.10 500	200 250 891	76 500 340	0.0004/0.0016 10/40
38,10	24	1.54 700	247 500 1 101	92 250 410	0.0004/0.0016 10/40
44,45	28	1.99 900	299 250 1 331	108 000 480	0.0004/0.0016 10/40
50,80	32	2.31 1 050	344 250 1 531	117 000 520	0.0004/0.0016 10/40

¹⁾ Loads are valid for the steel/steel spherical plain bearings without lubrication groove. For other bearings, refer to page 134

²⁾ Values are given for non protected bearings. For sealed and shielded bearings, refer to page 140



Designation system

Examples: ZW2PLS12,7TT-2CP6RP01
Q2PLC25,4PPCP109

Surface treatment of outer ring

No code Not plated
Z Cadmium plated external dimensions
SZ Zinc-nickel plated external dimensions

Material code **Inner ring material** **External ring material**
W Corrosion-resistant steel Corrosion-resistant steel
Q Bronze beryllium Corrosion-resistant steel
WQ Corrosion-resistant steel Bronze aluminium

Basic designation

Lubrication grooves

No code Without lubrication groove
S Lubrication by inner ring
C²⁾ Lubrication by outer ring
Y Lubrication by inner and outer ring

Bore code

Shield and seal

No code No shield and seal
TT³⁾ Sealed
PP³⁾ Shielded

Lubricant

No code Grease G354
-2 Grease G395

Surface treatment of inner ring

No code Not plated
CP6¹⁾ Chromium plated sphere
CP109¹⁾ XCR plating on sphere (chromium 6 free replacement to chromium plating)
CP55¹⁾ Passivated corrosion-resistant steel inner ring

Oversize

No code Standard outer diameter size
RP01 0.010 in/0,254 mm oversized outer diameter
RP02 0.020 in/0,508 mm oversized outer diameter

- 1) Available only for inner ring in corrosion-resistant steel material
2) In the outer ring sphere, central lubrication groove only for $d \leq 7,94$
3) Only available for $d \geq 7,94$

2.18 Self-lubricating light (metric dimensions)

LEN.. (XRA.. or 11..N..)²

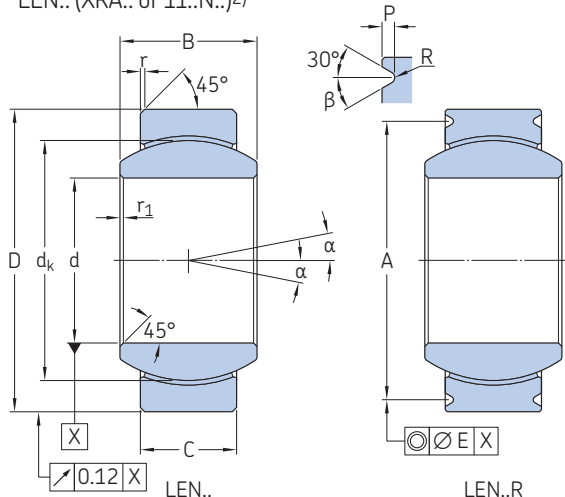

Technical specification	EN 2755
Product standards	EN 3048 (standard starting torque) EN 4037 (reduced starting torque)
Materials	
Liner	X1
Inner ring	Corrosion-resistant steel 440C
Outer ring	Corrosion-resistant steel 17-4PH

β	E
°	mm
30	0,12

Dimensions

Nominal bore code	Dimensions d Bore without liner	Δd_{mp}	Δd_s	d_a = d with lined bore H7	D	ΔD_{mp}	ΔD_s	C $\pm 0,1$	B 0/-0,06	d_k ≈
–	mm	μm		mm		μm		mm		
12	12	0/-8	+3/-11	12	22	0/-9	+6/-15	7	10	17,4
15/26	15	0/-8	+3/-11	15	26	0/-9	+6/-15	9	12	22,2
15 ¹⁾	15	0/-8	+3/-11	15	28	0/-9	+6/-15	9	12	22,2
17/30	17	0/-8	+3/-11	17	30	0/-9	+6/-15	10	14	25,4
17 ¹⁾	17	0/-8	+3/-11	17	32	0/-9	+6/-15	10	14	25,4
20	20	0/-10	+3/-13	20	35	0/-11	+8/-19	12	16	29,6
25	25	0/-10	+3/-13	25	42	0/-11	+8/-19	16	20	36,1
30	30	0/-10	+3/-13	30	47	0/-11	+8/-19	18	22	40,7
35	35	0/-12	+3/-15	35	55	0/-13	+10/-23	20	25	47,6
40	40	0/-12	+3/-15	40	62	0/-13	+10/-23	22	28	53,0
45	45	0/-12	+3/-15	45	68	0/-13	+10/-23	25	32	60,5
50	50	0/-12	+3/-15	50	75	0/-13	+10/-23	28	35	67,9
60 ¹⁾	60	0/-12	+3/-15	60	90	0/-13	+10/-23	36	44	80,0
70 ¹⁾	70	0/-12	+3/-15	70	105	0/-13	+10/-23	40	49	91,9

Dimensions cont., loads and torque

Nominal bore code	Dimensions r_1 +0,3/0	r	A +0,1/0 Code R	P 0/-0,2 Code PR	R +0,1/0	α^4	Mass =	Static limit loads Radial C_s	Axial C_a^3	Radial dynamic load C25	Starting torque ⁴⁾ Standard	Reduced
–	mm					°	g	kN			Nm	
12	0,1	0,5/0,8	20,2	–	0,7	0,2	11	17	46,4	3,7	0,12/0,8	0,008/0,1
15/26	0,1	0,5/0,8	24,2	24	0,7	0,2	9	30	79,5	8	0,12/0,8	0,01/0,12
15 ¹⁾	0,1	0,5/0,8	26,2	–	0,7	0,2	9	32	79,5	8	0,12/0,8	0,01/0,12
17/30	0,1	0,5/0,8	28,2	28	0,7	0,2	10	40	102,6	10,6	0,12/0,8	0,01/0,12
17 ¹⁾	0,1	0,5/0,8	30,2	–	0,7	0,2	10	49	102,6	10,6	0,12/0,8	0,01/0,12
20	0,1	0,6/1	33,2	33	0,7	0,2	9	65	147,4	17	0,12/0,8	0,01/0,12
25	0,1	0,6/1	39,4	38,8	0,9	0,3	7	115	221,7	28,7	0,25/1	0,015/0,25
30	0,1	0,6/1	44,4	43,8	0,9	0,3	6	160	285,6	38,2	0,4/2	0,02/0,4
35	0,1	0,8/1,2	51,8	–	1,4	0,3	7	229	374,5	48,7	0,4/2	0,02/0,4
40	0,1	0,8/1,2	58,8	–	1,4	0,3	7	315	462,7	60,7	0,6/2,7	0,025/0,5
45	0,1	0,8/1,2	64,8	–	1,4	0,3	7	460	605,8	81,6	0,6/2,7	0,03/0,6
50	0,1	0,8/1,2	71,8	–	1,4	0,3	7	560	770	105,6	0,6/2,7	0,03/0,6
60 ¹⁾	0,1	0,8/1,2	86,8	–	1,4	0,3	6	1 100	1 056	156,7	0,6/2,7	0,03/0,6
70 ¹⁾	0,1	0,8/1,2	101,8	–	1,4	0,3	6	1 540	1 361,6	197,3	0,6/2,7	0,03/0,6

1) SKF option 2) Parts are delivered and marked with XRA.., 11C..N.. (not plated) or 11F..N.. (chromium plated sphere) standard references

3) These values can be limited by the unstaking load (contact SKF for more information)

4) Values are given for non protected bearings. For sealed and shielded bearings, refer to page 149



Cross-reference designation system to XRA.. or 11..N..

Examples:	ZLEN17ARXTTFR10	Z	LEN	17	A	R	X	TT	F	R10
	LEN15/26PPD									
Surface treatment of outer ring	_____									
No code	Not plated									
Z¹⁾	Cadmium plated external dimensions									
SZ¹⁾	Zinc-nickel plated external dimensions									
Basic designation	_____									
Bore code	_____									
Lined bore	_____									
No code	Bore without liner									
A¹⁾	Lined bore									
Chamfer and groove	_____									
No code	Chamfered outer ring									
R and PR²⁾	Grooved outer ring									
Starting torque	_____									
No code	Standard									
X	Reduced									
Shield and seal	_____									
No code	No shield and seal									
TT¹⁾	Sealed									
PP¹⁾	Shielded									
Surface treatment of inner ring	_____									
No code	Not plated									
F	Chromium plated sphere									
D¹⁾	XCR plating on sphere (chromium 6 free replacement to chromium plating)									
V	Passivated inner ring									
K^{1) 3)}	XLHP coated sphere									
N^{1) 3)}	XLNT coated sphere									
H^{1) 3)}	XL coated sphere									
Oversize	_____									
No code	Standard outer diameter size									
R10¹⁾	0,1 mm oversized outer diameter									
R20¹⁾	0,2 mm oversized outer diameter									

¹⁾ SKF option

²⁾ Available only for bore codes 15/26, 17/30, 20, 25 and 30

³⁾ For sealed (code TT) or shielded (code PP) bearings with XLHP, XLNT or XL coated sphere, contact SKF to check for availability and technical suitability

2.19 Self-lubricating narrow (metric dimensions)

NEN.. (XRE..., 11..W., 11..N.. or 11..E..) bore code **05** to **25**

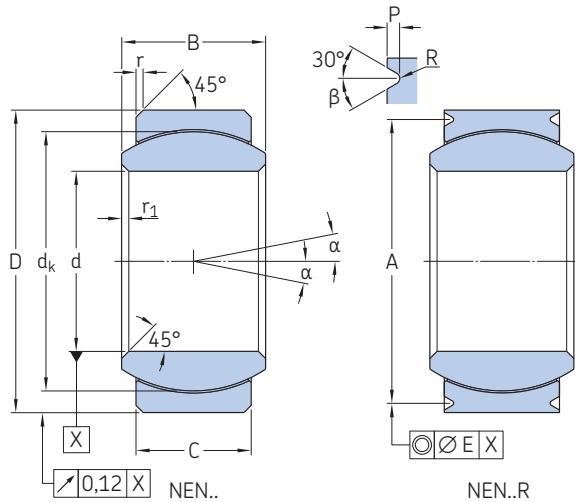

Technical specification	EN 2755
Product standards	EN 2584 (standard starting torque) EN 4038 (reduced starting torque)
Materials	X1
Liner	Corrosion-resistant steel 440C
Inner ring	Corrosion-resistant steel 17-4PH
Outer ring	

d	β	E
mm	°	mm
≤ 8	20	0,08
≥ 10	30	0,12

Dimensions

Nominal bore code	Dimensions d Bore without liner	Δdmp	Δds	da = d with lined bore H7	D	ΔDmp	ΔDs	C ±0,1	B 0/-0,06	dk ≈
–	mm	μm		mm		μm		mm		
05	5	0/-8	+2/-10	5	14	0/-8	+5/-13	5,5	7	11,1
06	6	0/-8	+2/-10	6	16	0/-8	+5/-13	6,5	9	12,7
08	8	0/-8	+2/-10	8	18	0/-8	+5/-13	7	10	14,3
10	10	0/-8	+2/-10	10	21	0/-9	+6/-15	8	10,5	15,9
12	12	0/-8	+3/-11	12	25	0/-9	+6/-15	10	13	19,8
15	15	0/-8	+3/-11	15	29	0/-9	+6/-15	12	15	25,4
17	17	0/-8	+3/-11	17	31	0/-9	+6/-15	13,5	16	27,0
22	22	0/-10	+3/-13	22	40	0/-11	+8/-19	18	22	34,9
25	25	0/-10	+3/-13	25	45	0/-11	+8/-19	20	25	38,7

Dimensions cont., loads and torque

Nominal bore code	Dimensions		A +0,1/0	P 0/-0,2	R +0,1/0	α ³⁾	Mass ≈	Static limit loads		Radial dynamic load C25	Starting torque ³⁾	
	r ₁ +0,3/0	r						Radial C _s	Axial C _a ²⁾		Standard	Reduced
–	mm					°	g	kN			Nm	
05	0,1	0,5/0,8	12,2	0,7	0,2	9	7	20,5	1,9	12,3	0,08/0,5	0,005/0,06
06	0,1	0,5/0,8	14,2	0,7	0,2	14	9	29,2	3,5	17,5	0,08/0,5	0,005/0,06
08	0,1	0,5/0,8	16,2	0,7	0,2	15	12	37,0	3,9	22,2	0,08/0,5	0,005/0,06
10	0,1	0,5/0,8	18,4	0,9	0,3	11	20	47,2	6,5	28,3	0,12/0,8	0,008/0,10
12	0,1	0,5/0,8	22,4	0,9	0,3	10	32	78,1	11,7	43,0	0,12/0,8	0,008/0,10
15	0,1	0,5/0,8	26,4	0,9	0,3	8	50	121,9	18,0	67,0	0,12/0,8	0,008/0,10
17	0,1	0,5/0,8	28,4	0,9	0,3	7	59	148,3	24,3	81,0	0,12/0,8	0,008/0,10
22	0,1	0,6/1	36,8	1,4	0,3	8	126	268,6	45,5	147,7	0,25/1,0	0,015/0,25
25	0,1	0,6/1	41,8	1,4	0,3	8	185	324,7	55,9	162,4	0,25/1,0	0,015/0,25

¹⁾ Parts are delivered and marked with the following standard references: XRE..., 11C..W.. (Not plated) or 11F..W.. (Chromium plated sphere) for bore codes 5 and 22, 11C..N.. (Not plated) or 11F..N.. (Chromium plated sphere) for bore code 6 and 10, 11C..E.. (Not plated) or 11F..E.. (Chromium plated sphere) for bore code 8 and ≥ 12 (except 22)

²⁾ These values can be limited by the unstaking load (contact SKF for more information)

³⁾ Values are given for non protected bearings. For sealed and shielded bearings, refer to page 149



Cross-reference designation system to XRE., 11..W., 11..N.. or 11..E..

Examples:	Z	NEN	17	A	R	X	TT	F	R10
ZNEN17ARXTTFR10 NEN06PPD									
Surface treatment of outer ring	_____								
No code	Not plated								
Z¹⁾	Cadmium plated external dimensions								
SZ¹⁾	Zinc-nickel plated external dimensions								
Basic designation	_____								
Bore code	_____								
Lined bore	_____								
No code	Bore without liner								
A^{1) 2)}	Lined bore								
Chamfer and groove	_____								
No code	Chamfered outer ring								
R	Grooved outer ring								
Starting torque	_____								
No code	Standard								
X	Reduced								
Shield and seal	_____								
No code	No shield and seal								
TT^{1) 2)}	Sealed								
PP^{1) 2)}	Shielded								
Surface treatment of inner ring	_____								
No code	Not plated								
F	Chromium plated sphere								
D¹⁾	XCR plating on sphere (chromium 6 free replacement to chromium plating)								
V	Passivated inner ring								
K^{1) 3)}	XLHP coated sphere								
N^{1) 3)}	XLNT coated sphere								
H^{1) 3)}	XL coated sphere								
Oversize	_____								
No code	Standard outer diameter size								
R10¹⁾	0,1 mm oversized outer diameter								
R20¹⁾	0,2 mm oversized outer diameter								

1) SKF option

2) Only available for $d \geq 6$

3) For sealed (code TT) or shielded (code PP) bearings with XLHP, XLNT or XL coated sphere, contact SKF to check for availability and technical suitability

2.19 Self-lubricating narrow (metric dimensions)

NEN.. (XRE..., 11..W..., 11..N.. or 11..E...¹) bore code **30** to **55**

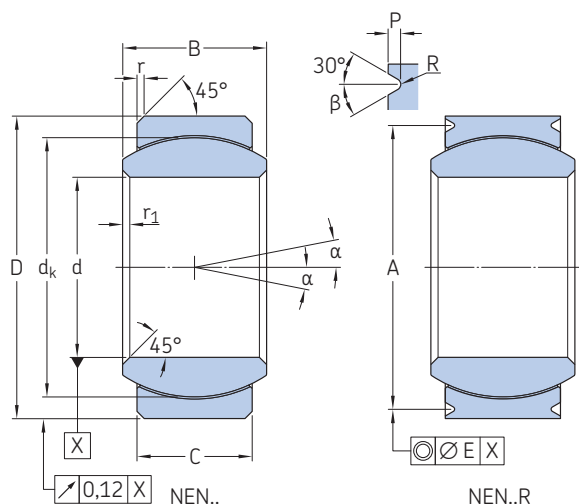

Technical specification	EN 2755
Product standards	EN 2584 (standard starting torque) EN 4038 (reduced starting torque)
Materials	X1
Liner	Corrosion-resistant steel 440C
Inner ring	Corrosion-resistant steel 17-4PH
Outer ring	

d	β	E
mm	°	mm
≤ 8	20	0,08
≥ 10	30	0,12

Dimensions

Nominal bore code	Dimensions d Bore without liner	Δdmp	Δds	d _a = d with lined bore H7	D	ΔDmp	ΔDs	C ±0,1	B 0/-0,06	d _k ≈
–	mm	μm		mm		μm		mm		
30	30	0/-10	+3/-13	30	51	0/-13	+10/-23	24	28	45,2
35	35	0/-12	+3/-15	35	57	0/-13	+10/-23	26	31	52,0
40	40	0/-12	+3/-15	40	64	0/-13	+10/-23	29	34	58,0
45	45	0/-12	+3/-15	45	72	0/-13	+10/-23	32	37	64,0
50	50	0/-12	+3/-15	50	80	0/-15	+13/-28	34	41	72,0

Dimensions cont., loads and torque

Nominal bore code	Dimensions		A +0,1/0	P 0/-0,2	R +0,1/0	α ³⁾	Mass ≈ g	Static limit loads		Radial dynamic load C ₂₅	Starting torque ³⁾	
	r ₁ +0,3/0	r						Radial C _s	Axial C _a ²⁾		Standard	Reduced
–	mm					°		kN			Nm	
30	0,1	0,6/1	47,8	1,4	0,3	6	300	433,4	77,8	216,7	0,4/2,0	0,02/0,4
35	0,1	0,8/1,2	53,8	1,4	0,3	7	340	543,4	92,2	271,7	0,4/2,0	0,02/0,4
40	0,1	0,8/1,2	60,8	1,4	0,3	6	460	680,9	113,4	340,3	0,6/2,7	0,03/0,6
45	0,1	0,8/1,2	68,8	1,4	0,3	5	630	833,9	135,4	416,9	0,6/2,7	0,03/0,6
50	0,1	0,8/1,2	76,8	1,4	0,3	7	870	981,4	154,2	490,7	0,6/2,7	0,03/0,6
55¹⁾	0,1	0,8/1,2	92,8	1,5	0,3	10	1 580	1 350,5	235,8	–	0,6/3,5	0,03/0,6

¹⁾ Parts are delivered and marked with the following standard references: XRE..., 11C..W.. (Not plated) or 11F..W.. (Chromium plated sphere) for bore codes 5 and 22, 11C..N.. (Not plated) or 11F..N.. (Chromium plated sphere) for bore code 6 and 10, 11C..E.. (Not plated) or 11F..E.. (Chromium plated sphere) for bore code 8 and ≥ 12 (except 22)

²⁾ These values can be limited by the unstaking load (contact SKF for more information)

³⁾ Values are given for non protected bearings. For sealed and shielded bearings, refer to page 149



Cross-reference designation system to XRE., 11..W., 11..N.. or 11..E..

Examples:	Z	NEN	17	A	R	X	TT	F	R10
ZNEN17ARXTTFR10 NEN06PPD									
Surface treatment of outer ring	_____								
No code	Not plated								
Z¹⁾	Cadmium plated external dimensions								
SZ¹⁾	Zinc-nickel plated external dimensions								
Basic designation	_____								
Bore code	_____								
Lined bore	_____								
No code	Bore without liner								
A^{1) 2)}	Lined bore								
Chamfer and groove	_____								
No code	Chamfered outer ring								
R	Grooved outer ring								
Starting torque	_____								
No code	Standard								
X	Reduced								
Shield and seal	_____								
No code	No shield and seal								
TT^{1) 2)}	Sealed								
PP^{1) 2)}	Shielded								
Surface treatment of inner ring	_____								
No code	Not plated								
F	Chromium plated sphere								
D¹⁾	XCR plating on sphere (chromium 6 free replacement to chromium plating)								
V	Passivated inner ring								
K^{1) 3)}	XLHP coated sphere								
N^{1) 3)}	XLNT coated sphere								
H^{1) 3)}	XL coated sphere								
Oversize	_____								
No code	Standard outer diameter size								
R10¹⁾	0,1 mm oversized outer diameter								
R20¹⁾	0,2 mm oversized outer diameter								

¹⁾ SKF option

²⁾ Only available for $d \geq 6$

³⁾ For sealed (code TT) or shielded (code PP) bearings with XLHP, XLNT or XL coated sphere, contact SKF to check for availability and technical suitability

2.20 Self-lubricating wide (metric dimensions)

WEN.. (XRL..., 11..E.. or 11..W..)² bore code **05** to **17**

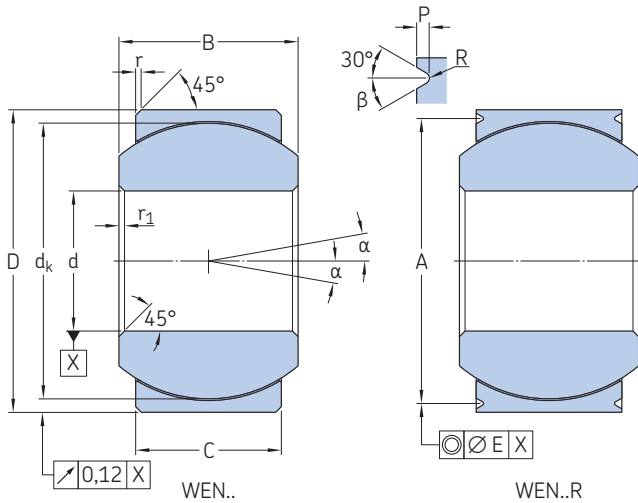

Technical specification	EN 2755
Product standards	EN 2585 (standard starting torque) EN 4039 (reduced starting torque)
Materials	X1
Liner	Corrosion-resistant steel 440C
Inner ring	Corrosion-resistant steel 17-4PH
Outer ring	

d	β	E
mm	°	mm
≤ 8	20	0,08
≥ 10	30	0,12

Dimensions

Nominal bore code	Dimensions d Bore without liner	Δdmp	Δds	da = d with lined bore H7	D	ΔDmp	ΔDs	C ±0,1	B 0/-0,06	dk ≈
–	mm	μm		mm		μm		mm		
05 ⁵⁾	5	0/-8	+2/-10	5	16	0/-8	+5/-13	8,5	11	13,4
06	6	0/-8	+2/-10	6	16	0/-8	+5/-13	8,5	11	13,4
08	8	0/-8	+2/-10	8	18	0/-8	+5/-13	8	11	15,1
10	10	0/-8	+2/-10	10	21	0/-9	+6/-15	10	12,5	17,5
12	12	0/-8	+3/-11	12	26	0/-9	+6/-15	13	16	22,3
15	15	0/-8	+3/-11	15	29	0/-9	+6/-15	13,5	17	25,4
17	17	0/-8	+3/-11	17	30	0/-9	+6/-15	14,5	18	27,0

Dimensions cont., loads and torque

Nominal bore code	Dimensions r1 +0,3/0	r	A +0,1/0	P 0/-0,2	R +0,1/0	α ⁴⁾	Mass ≈	Static limit loads Radial Cs	Axial Ca ³⁾	Radial dynamic load C25	Starting torque ⁴⁾ Standard	Reduced
–	mm					°	g	kN			Nm	
05 ⁵⁾	0,1	0,5/0,8	14,2	0,7	0,2	15	16	42,6	7,2	25,6	0,08/0,5	0,005/0,06
06	0,1	0,5/0,8	14,2	0,7	0,2	15	16	42,6	7,2	25,6	0,08/0,5	0,005/0,06
08	0,1	0,5/0,8	16,2	0,7	0,2	14	17	45,7	6,4	27,4	0,12/0,8	0,006/0,08
10	0,1	0,5/0,8	18,4	0,9	0,3	10	27	68,7	11,7	41,2	0,12/0,8	0,008/0,1
12	0,1	0,5/0,8	23,4	0,9	0,3	10	49	116,4	21,5	64	0,12/0,8	0,008/0,1
15	0,1	0,5/0,8	26,4	0,9	0,3	9	62	139,0	24,1	76,5	0,12/0,8	0,01/0,12
17	0,1	0,5/0,8	27,4	0,9	0,3	9	69	159,1	29,0	87,5	0,12/0,8	0,01/0,12

1) SKF option

2) Parts are delivered and marked with the following standard references: XRL..., 11C..E.. (Not plated) or 11F..E.. (Chromium plated sphere) for bore code 5, 11C..W.. (Not plated) or 11F..W.. (Chromium plated sphere) for bore codes ≥ 6

3) These values can be limited by the unstaking load (contact SKF for more information)

4) Values are given for non protected bearings. For sealed and shielded bearings, refer to page 149

5) SKF option for reduced starting torque bearings



Cross-reference designation system to XRL..., 11..E.. or 11..W..

Examples:	Z	WEN	17	A	R	X	TT	F	R10
ZWEN17ARXTTFR10 WEN05PPD									
Surface treatment of outer ring	_____								
No code	Not plated								
Z¹⁾	Cadmium plated external dimensions								
SZ¹⁾	Zinc-nickel plated external dimensions								
Basic designation	_____								
Bore code	_____								
Lined bore	_____								
No code	Bore without liner								
A^{1) 2)}	Lined bore								
Chamfer and groove	_____								
No code	Chamfered outer ring								
R	Grooved outer ring								
Starting torque	_____								
No code	Standard								
X³⁾	Reduced								
Shield and seal	_____								
No code	No shield and seal								
TT^{1) 2)}	Sealed								
PP^{1) 2)}	Shielded								
Surface treatment of inner ring	_____								
No code	Not plated								
F	Chromium plated sphere								
D¹⁾	XCR plating on sphere (chromium 6 free replacement to chromium plating)								
V	Passivated inner ring								
K^{1) 4)}	XLHP coated sphere								
N^{1) 4)}	XLNT coated sphere								
H^{1) 4)}	XL coated sphere								
Oversize	_____								
No code	Standard outer diameter size								
R10¹⁾	0,1 mm oversized outer diameter								
R20¹⁾	0,2 mm oversized outer diameter								

1) SKF option

2) Only available for $d \geq 6$

3) SKF option for $d = 5$ and $d = 55$

4) For sealed (code TT) or shielded (code PP) bearings with XLHP, XLNT or XL coated sphere, contact SKF to check for availability and technical suitability

2.20 Self-lubricating wide (metric dimensions)

WEN.. (XRL..., 11..E.. or 11..W..)² bore code 20 to 60

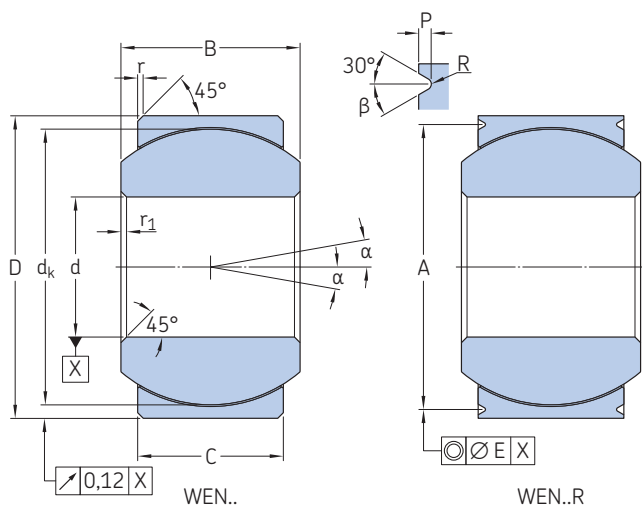

Technical specification	EN 2755
Product standards	EN 2585 (standard starting torque) EN 4039 (reduced starting torque)
Materials	X1
Liner	Corrosion-resistant steel 440C
Inner ring	Corrosion-resistant steel 17-4PH
Outer ring	

d	β	E
mm	°	mm
≤ 8	20	0,08
≥ 10	30	0,12

Dimensions

Nominal bore code	Dimensions d Bore without liner	Δdmp	Δds	d _a = d with lined bore H7	D	ΔDmp	ΔDs	C ±0,1	B 0/-0,06	d _k ≈
–	mm	μm		mm		μm		mm		
20	20	0/-10	+3/-13	20	35	0/-11	+8/-19	16	20	30,9
25	25	0/-10	+3/-13	25	54	0/-13	+10/-23	26	32	47,6
30	30	0/-10	+3/-13	30	60	0/-13	+10/-23	28	34	53,2
35	35	0/-12	+3/-15	35	65	0/-13	+10/-23	29	36	58,0
40	40	0/-12	+3/-15	40	68	0/-13	+10/-23	31	38	60,4
45	45	0/-12	+3/-15	45	76	0/-13	+10/-23	33	41	67,9
50	50	0/-12	+3/-15	50	82	0/-15	+13/-28	35	44	74,6
55 ⁵⁾	55	0/-12	+3/-15	55	96	0/-15	+13/-28	40	52	82,0
60 ¹⁾	60	0/-12	+3/-15	60	105	0/-15	+13/-28	48	60	92,0

Dimensions cont., loads and torque

Nominal bore code	Dimensions r ₁ +0,3/0	r	A +0,1/0	P 0/-0,2	R +0,1/0	α ⁴⁾	Mass ≈	Static limit loads Radial C _s	Axial C _a ³⁾	Radial dynamic load C ₂₅	Starting torque ⁴⁾ Standard	Reduced
–	mm					°	g	kN			Nm	
20	0,1	0,5/0,8	31,8	1,4	0,3	8	104	207,5	36,0	113,9	0,12/0,8	0,01/0,12
25	0,1	0,6/1	50,8	1,4	0,3	9	445	496,6	93,2	248,3	0,25/1	0,015/0,25
30	0,1	0,8/1,2	56,8	1,4	0,3	8	480	587,5	109,6	293,7	0,4/2	0,02/0,4
35	0,1	0,8/1,2	61,8	1,4	0,3	8	565	666,0	117,6	333	0,4/2	0,02/0,4
40	0,1	0,8/1,2	64,8	1,4	0,3	8	600	745,6	136,6	372,8	0,6/2,7	0,025/0,5
45	0,1	0,8/1,2	72,8	1,4	0,3	8	800	895,9	155,6	447,9	0,6/2,7	0,03/0,6
50	0,1	0,8/1,2	78,8	1,4	0,3	8	970	1 024,7	176,2	512,3	0,6/2,7	0,03/0,6
55 ⁵⁾	0,1	0,8/1,2	92,8	1,4	0,3	10	1 580	1 298,7	221,2	649,3	0,6/2,7	0,03/0,6
60 ¹⁾	0,1	0,8/1,2	101,8	1,5	0,3	9	2 250	1 681,8	243,7	864	0,6/2,7	0,03/0,6

1) SKF option

2) Parts are delivered and marked with the following standard references: XRL..., 11C..E.. (Not plated) or 11F..E.. (Chromium plated sphere) for bore code 5, 11C..W.. (Not plated) or 11F..W.. (Chromium plated sphere) for bore codes ≥ 6

3) These values can be limited by the unstaking load (contact SKF for more information)

4) Values are given for non protected bearings. For sealed and shielded bearings, refer to page 149

5) SKF option for reduced starting torque bearings



Cross-reference designation system to XRL..., 11..E.. or 11..W..

Examples:	ZWEN17ARXTTFR10 WEN05PPD	Z	WEN	17	A	R	X	TT	F	R10
Surface treatment of outer ring										
No code	Not plated									
Z¹⁾	Cadmium plated external dimensions									
SZ¹⁾	Zinc-nickel plated external dimensions									
Basic designation										
Bore code										
Lined bore										
No code	Bore without liner									
A^{1) 2)}	Lined bore									
Chamfer and groove										
No code	Chamfered outer ring									
R	Grooved outer ring									
Starting torque										
No code	Standard									
X³⁾	Reduced									
Shield and seal										
No code	No shield and seal									
TT^{1) 2)}	Sealed									
PP^{1) 2)}	Shielded									
Surface treatment of inner ring										
No code	Not plated									
F	Chromium plated sphere									
D¹⁾	XCR plating on sphere (chromium 6 free replacement to chromium plating)									
V	Passivated inner ring									
K^{1) 4)}	XLHP coated sphere									
N^{1) 4)}	XLNT coated sphere									
H^{1) 4)}	XL coated sphere									
Oversize										
No code	Standard outer diameter size									
R10¹⁾	0,1 mm oversized outer diameter									
R20¹⁾	0,2 mm oversized outer diameter									

1) SKF option

2) Only available for $d \geq 6$

3) SKF option for $d = 5$ and $d = 55$

4) For sealed (code TT) or shielded (code PP) bearings with XLHP, XLNT or XL coated sphere, contact SKF to check for availability and technical suitability

2.21 Self-lubricating high-misalignment (metric dimensions)

HMEN... (RL..SP.. or 11E..H..)²

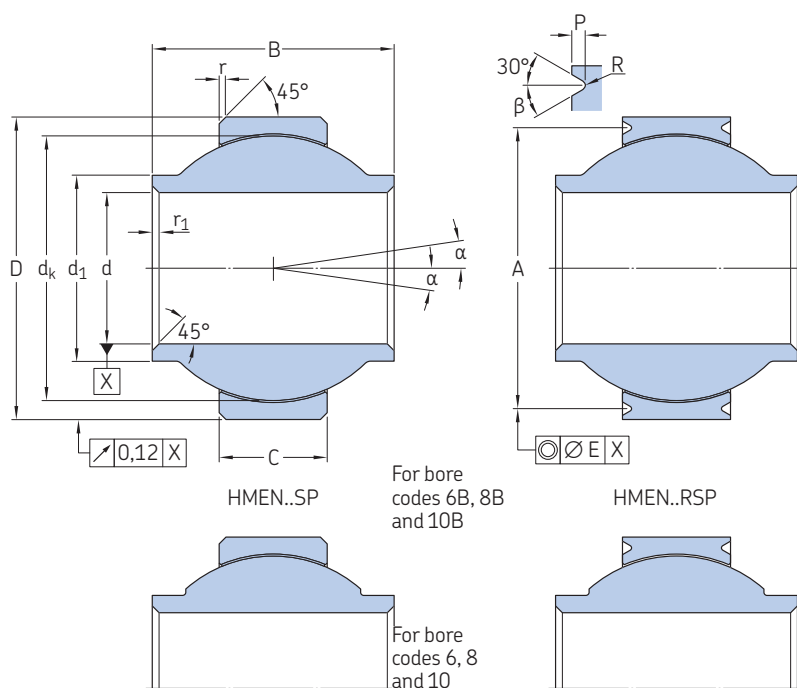

Technical specification	EN 2755
Product standards	EN 4040
Materials	X1
Liner	Corrosion-resistant steel 440C
Inner ring	Corrosion-resistant steel 17-4PH
Outer ring	

d	β	E
mm	°	mm
6	20	0,08
8	30	0,08
10	30	0,12

2.21

Dimensions

Nominal bore code	Dimensions d Bore without liner	Δdmp	Δds	da = d with lined bore H7	D	ΔDmp	ΔDs	C ±0,1	B 0/-0,06	dk ≈	d1 ≈
–	mm	μm		mm		μm		mm			
06 ¹⁾	6	0/-8	+5/-13	6	18	0/-8	+2/-10	8	14	15,0	9
06B	6	0/-8	+5/-13	6	18	0/-8	+2/-10	8	14	15,0	9
08 ¹⁾	8	0/-9	+6/-15	8	21	0/-8	+2/-10	10	15	17,5	11
08B	8	0/-9	+6/-15	8	21	0/-8	+2/-10	10	15	17,5	11
10 ¹⁾	10	0/-9	+6/-15	10	26	0/-8	+2/-10	13	20	22,2	13,5
10B	10	0/-9	+6/-15	10	26	0/-8	+2/-10	13	20	22,2	13,5

Dimensions cont., loads and torque

Nominal bore code	Dimensions r1 +0,5/0	r +0,3/0	A +0,1/0	P 0/-0,2	R +0,1/0	α ⁴⁾	Mass ≈	Static limit loads Radial Cs	Axial Ca ³⁾	Radial dynamic load C25	Starting torque ⁴⁾ Standard	Reduced
–	mm					°	g	kN			Nm	
06 ¹⁾	0,3	0,5	16,2	0,7	0,2	9	15	41,5	5,1	16,6	0,12/0,8	0,01/0,2
06B	0,3	0,5	16,2	0,7	0,2	20	15	41,5	5,1	16,6	0,12/0,8	0,01/0,2
08 ¹⁾	0,3	0,5	18,4	0,9	0,3	8	22	63	9,5	25,2	0,12/0,8	0,02/0,4
08B	0,3	0,5	18,4	0,9	0,3	15	22	63	9,5	25,2	0,12/0,8	0,02/0,4
10 ¹⁾	0,3	0,5	23,4	0,9	0,3	10	48	105,1	18,6	42,2	0,12/0,8	0,02/0,4
10B	0,3	0,5	23,4	0,9	0,3	16	48	105,1	18,6	42,2	0,12/0,8	0,02/0,4

1) SKF option

2) Parts are delivered and marked with RL..SP.. or 11E..H.. standard references

3) These values can be limited by the unstaking load (contact SKF for more information)

4) Values are given for non protected bearings. For sealed and shielded bearings, refer to page 149



Cross-reference designation system to RL..SP.. or 11E..H..

Examples:	ZHMEN06ARXTTFR10	Z	HMEN	06	A	R	X	TT	F	R10
Surface treatment of outer ring										
No code	Not plated									
Z¹⁾	Cadmium plated external dimensions									
SZ¹⁾	Zinc-nickel plated external dimensions									
Basic designation										
Bore code										
Lined bore										
No code	Bore without liner									
A^{1) 2)}	Lined bore									
Chamfer and groove										
No code	Chamfered outer ring									
R	Grooved outer ring									
Starting torque										
No code	Standard									
X	Reduced									
Shield and seal										
No code	No shield and seal									
TT^{1) 2)}	Sealed									
PP^{1) 2)}	Shielded									
Surface treatment of inner ring										
No code	Not plated									
F¹⁾	Chromium plated sphere									
D¹⁾	XCR plating on sphere (chromium 6 free replacement to chromium plating)									
V	Passivated inner ring									
K^{1) 3)}	XLHP coated sphere									
N^{1) 3)}	XLNT coated sphere									
H^{1) 3)}	XL coated sphere									
Oversize										
No code	Standard outer diameter size									
R10¹⁾	0,1 mm oversized outer diameter									
R20¹⁾	0,2 mm oversized outer diameter									

1) SKF option

2) Only available for $d \geq 6$

3) For sealed (code TT) or shielded (code PP) bearings with XLHP, XLNT or XL coated sphere, contact SKF to check for availability and technical suitability

2.22 Self-lubricating high misalignment (metric dimensions)

XRT...

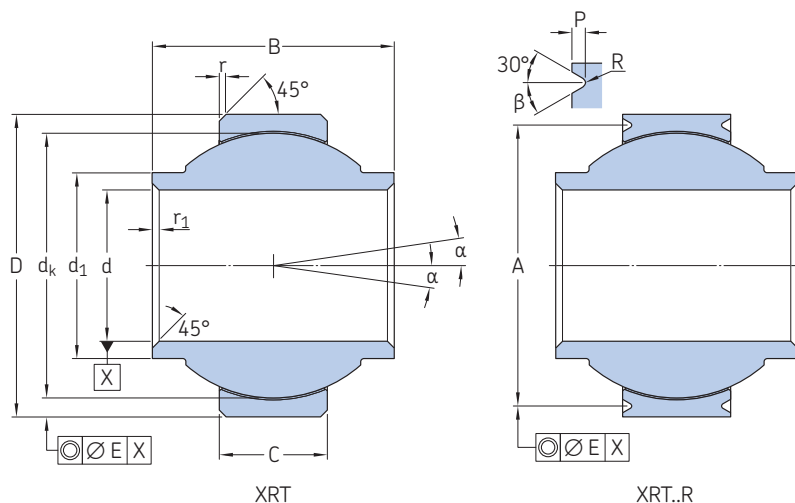

Technical specification	–
Product standards	–
Materials	
Liner	X1
Inner ring	Corrosion-resistant steel 440C
Outer ring	Corrosion-resistant steel 17-4PH

d	β	E
mm	°	mm
≤ 6	20	0,08
≥ 8	30	0,12

Dimensions

Nominal bore code	Dimensions d Bore without liner	Δdmp	da = d with lined bore H7	D	ΔDmp	C ±0,1	B 0/–0,06	dk ≈	d1 =
–	mm	μm	mm		μm	mm			
5	5	0/–8	5	14	0/–8	5	12,5	11,1	7,8
6	6	0/–8	6	19	0/–8	6	15	15,1	9,6
8	8	0/–8	8	25	0/–9	9	21	19,8	13,3
10	10	0/–8	10	25	0/–9	9	21	19,8	13,3
12	12	0/–8	12	30	0/–9	10	24	25,0	17,7
17	17	0/–8	17	36	0/–11	14	30	31,5	21,8
20	20	0/–10	20	40	0/–11	16	33	34,0	24,0
22	22	0/–10	22	45	0/–11	16	36	38,9	28,3
25	25	0/–10	25	54	0/–13	21	48	47,6	32,2
30	30	0/–10	30	65	0/–13	25	48	57,1	38,8

Dimensions cont., loads and torque

Nominal bore code	Dimensions r1	r	A	P	R	α ²⁾	Mass ≈	Static limit loads Radial Cs	Axial Ca ¹⁾	Radial dynamic load C25	Starting torque ²⁾ Standard	Reduced
–	mm					°	g	kN			Nm	
5	0,1	0,5	12,2	0,7	0,2	15	8	16,5	0,7	6,6	0,06/0,3	0,005/0,06
6	0,1	0,5	17,2	0,7	0,2	24	17	30,5	1,3	12,2	0,06/0,3	0,005/0,06
8	0,1	0,5	22,4	0,9	0,3	20	39	70,4	8,4	28,2	0,08/0,4	0,005/0,06
10	0,1	0,5	22,4	0,9	0,3	20	34	70,4	8,4	28,2	0,1/0,5	0,008/0,1
12	0,1	0,5	27,4	0,9	0,3	20	65	95,8	10,3	38,3	0,1/0,5	0,008/0,1
17	0,1	0,5	33,4	0,9	0,3	20	110	174,6	25,8	69,8	0,12/0,7	0,008/0,1
20	0,1	0,5	36,8	1,4	0,3	19	142	234,4	33,3	93,8	0,12/0,7	0,008/0,1
22	0,1	0,5	41,8	1,4	0,3	19	194	266,3	33,3	106,5	0,25/1	0,015/0,25
25	0,1	0,5	50,8	1,4	0,3	21	401	391,8	55,9	156,7	0,25/1	0,015/0,25
30	0,1	0,5	61,8	1,4	0,3	21	600	583,7	75,9	233,5	0,4/1,8	0,02/0,4

¹⁾ These values can be limited by the unstaking load (contact SKF for more information)

²⁾ Values are given for non protected bearings. For sealed and shielded bearings, refer to page 149



Designation system

Examples:	ZXRT17ARXTTCP6R10	Z	XRT	17	A	R	X	TT	CP6	R10
	XRT 5PPCP109									
Surface treatment of outer ring										
No code	Not plated									
Z	Cadmium plated external dimensions									
SZ	Zinc-nickel plated external dimensions									
Basic designation										
Bore code										
Lined bore										
No code	Bore without liner									
A¹⁾	Lined bore									
Chamfer and groove										
No code	Chamfered outer ring									
R	Grooved outer ring									
Starting torque										
No code	Standard									
X	Reduced									
Shield and seal										
No code	No shield and seal									
TT¹⁾	Sealed									
PP¹⁾	Shielded									
Surface treatment of inner ring										
No code	Not plated									
CP6	Chromium plated sphere									
CP109	XCR plating on sphere (chromium 6 free replacement to chromium plating)									
CP55	Passivated inner ring									
Oversize										
No code	Standard outer diameter size									
R10	0,1 mm oversized outer diameter									
R20	0,2 mm oversized outer diameter									

¹⁾ Only available for $d \geq 6$

2.23 Self-lubricating pre-staked (metric dimensions)

XRL..FR

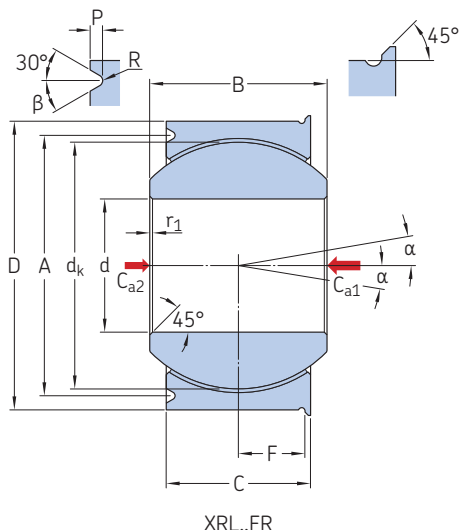

Technical specification	–
Product standards	–
Materials	X1
Liner	Corrosion-resistant steel 440C
Inner ring	Corrosion-resistant steel 17-4PH
Outer ring	Corrosion-resistant steel 17-4PH

d	β
mm	°
≤ 6	20
≥ 8	30

Dimensions

Nominal bore code	Dimensions d Bore without liner	Δdmp	d _a = d with lined bore H7	D	ΔDmp	C ±0,1	B 0/–0,06	d _k ≈
–	mm	μm	mm		μm	mm		
5	5	0/–8	5	16	0/–8	8,5	11	13,4
6	6	0/–8	6	16	0/–8	8,5	11	13,4
8	8	0/–8	8	18	0/–8	8	11	15,1
10	10	0/–8	10	21	0/–9	10	12,5	17,5
12	12	0/–8	12	26	0/–9	13	16	22,3
15	15	0/–8	15	29	0/–9	13,5	17	25,4
17	17	0/–8	17	30	0/–9	14,5	18	27,0
20	20	0/–10	20	35	0/–11	16	20	30,9
25	25	0/–10	25	54	0/–13	26	32	47,6
30	30	0/–10	30	60	0/–13	28	34	53,2
35	35	0/–12	35	65	0/–13	29	36	58,0
40	40	0/–12	40	68	0/–13	31	38	60,4
45	45	0/–12	45	76	0/–13	33	41	67,9
50	50	0/–12	50	82	0/–13	35	44	74,6

Dimensions cont., loads and torque

Nominal bore code	Dimensions						Mass ≈	Static limit loads			Radial dynamic load C ₂₅	Starting torque ¹⁾	
	r ₁ +0,3/0	F +0,1/0	A +0,1/0	P 0/–0,2	R +0,1/0	α ¹⁾		Axial C _{a1}	Axial C _{a2}	Radial C _s		Standard	Reduced
–	mm						g	kN			Nm		
5	0,1	3,7	14,2	0,7	0,2	15	16	7,2	5	42,6	25,6	0,08/0,5	0,005/0,06
6	0,1	3,7	14,2	0,7	0,2	15	16	7,2	5	42,6	25,6	0,08/0,5	0,005/0,06
8	0,1	3,45	16,2	0,7	0,2	14	17	6,4	5	45,7	27,4	0,12/0,8	0,006/0,08
10	0,1	4,25	18,4	0,9	0,3	10	27	11,7	9	68,7	41,2	0,12/0,8	0,008/0,1
12	0,1	5,75	23,4	0,9	0,3	10	49	21,5	14	116,4	64	0,12/0,8	0,008/0,1
15	0,1	6	26,4	0,9	0,3	9	62	24,1	16	139,0	76,5	0,12/0,8	0,01/0,12
17	0,1	6,5	27,4	0,9	0,3	9	69	29	18	59,1	87,5	0,12/0,8	0,01/0,12
20	0,1	6,75	31,8	1,4	0,3	8	104	36	23	207,5	113,9	0,12/0,8	0,01/0,12
25	0,1	11,75	50,8	1,4	0,3	9	445	93,2	40	496,6	248,3	0,25/1	0,015/0,25
30	0,1	12,75	56,8	1,4	0,3	8	480	109,6	45	745,6	293,7	0,4/2	0,02/0,4
35	0,1	13,25	61,8	1,4	0,3	8	565	117,6	50	895,9	333	0,4/2	0,02/0,4
40	0,1	14,25	64,8	1,4	0,3	8	600	136,6	53	1 024,7	372,8	0,6/2,7	0,025/0,5
45	0,1	15,25	72,8	1,4	0,3	8	800	155,6	60	1 298,7	447,9	0,6/2,7	0,03/0,6
50	0,1	16,25	78,8	1,4	0,3	8	970	176,2	65	1 681,8	512,3	0,6/2,7	0,03/0,6

¹⁾ Values are given for non protected bearings. For sealed and shielded bearings, refer to page 149



Designation system

Examples: ZXRL17FRARXTTCP6R10
XRL 5FRPPCP109

Surface treatment of outer ring

No code Not plated
Z Cadmium plated external dimensions
SZ Zinc-nickel plated external dimensions

Basic designation

Bore code

Lined bore

No code Bore without liner
A¹⁾ Lined bore

Chamfer and groove

No code Chamfered outer ring
R Grooved outer ring

Starting torque

No code Standard
X Reduced

Shield and seal

No code No shield and seal
TT¹⁾ Sealed
PP¹⁾ Shielded

Surface treatment of inner ring

No code Not plated
CP6 Chromium plated sphere
CP109 XCR plating on sphere (chromium 6 free replacement to chromium plating)
CP55 Passivated inner ring

Oversize

No code Standard outer diameter size
R10 0,1 mm oversized outer diameter
R20 0,2 mm oversized outer diameter

¹⁾ Only available for $d \geq 6$

2.24 Self-lubricating narrow controlled clearance (inch dimensions)

SN..ZT...

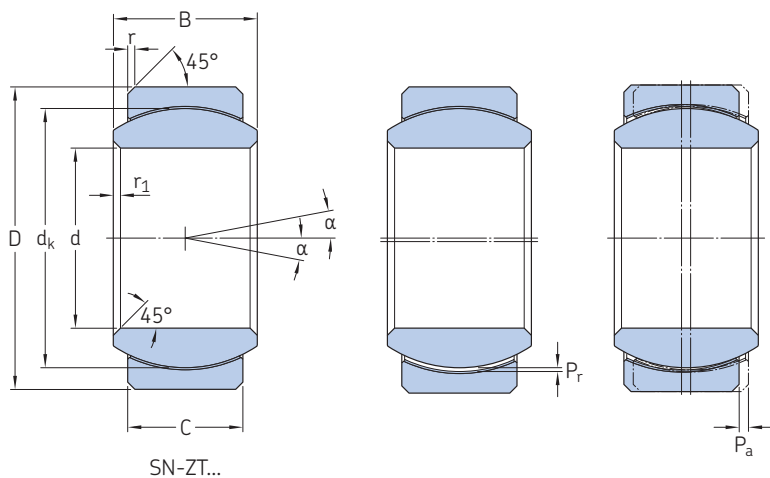

Technical specification	–
Product standards	–
Materials	X1
Liner	Corrosion-resistant steel 440C
Inner ring	Corrosion-resistant steel 17-4PH
Outer ring	

2.24

Dimensions

Nominal bore code	Size	Dimensions								
		d	D	C	B	d _k	r	r ₁	α	
		0/-0.0005 0/-0,0127	0/-0.0005 0/-0,0127	0/-0.010 0/-0,254	0/-0.002 0/-0,051	≈	0/-0.010 0/-0,254	+0.010/0 +0,254/0		
–		in/mm								°
03	3/16	0.1900 4,8260	0.5625 14,2875	0.223 5,664	0.281 7,137	0.437 11,100	0.020 0,508	0.005 0,127	10	
04	1/4	0.2500 6,3500	0.6562 16,6675	0.255 6,477	0.343 8,712	0.500 12,700	0.020 0,508	0.005 0,127	12	
05	5/16	0.3125 7,9375	0.7500 19,0500	0.286 7,264	0.375 9,525	0.593 15,062	0.025 0,635	0.005 0,127	11	
06	3/8	0.3750 9,5250	0.8125 20,6375	0.317 8,052	0.406 10,312	0.625 15,875	0.025 0,635	0.005 0,127	10	
08	1/2	0.5000 12,7000	1.0000 25,4000	0.395 10,033	0.500 12,700	0.781 19,837	0.030 0,762	0.005 0,127	9°30'	
10	5/8	0.6250 15,8750	1.1875 30,1625	0.505 12,827	0.625 15,875	1.000 25,400	0.030 0,762	0.005 0,127	8°30'	
12	3/4	0.7500 19,0500	1.4375 36,5125	0.598 15,189	0.750 19,050	1.250 31,750	0.030 0,762	0.005 0,127	8°30'	
14	7/8	0.8750 22,2250	1.5625 39,6875	0.708 17,983	0.875 22,225	1.375 34,925	0.040 1,016	0.005 0,127	9	
16	1	1.0000 25,4000	1.7500 44,4500	0.802 20,371	1.000 25,400	1.562 39,675	0.040 1,016	0.005 0,127	9°30'	



Designation system

Examples: SN04ZTCY2
SN12ZT

SN 04 ZT C Y2

Basic designation

Bore code (multiples of 1/16 inch)

Surface treatment of outer ring

No code Not plated
C Cadmium plated external dimensions
J Zinc-nickel plated external dimensions

Oversize

No code Standard outer diameter size
Y1 0.005 in/0,127 mm oversized outer diameter
Y2 0.010 in/0,254 mm oversized outer diameter
Y3 0.015 in/0,381 mm oversized outer diameter
Y4 0.020 in/0,508 mm oversized outer diameter

Loads, torque and clearance

Nominal bore code	Size	Mass ≈	Static limit loads		No load dynamic torque max	Clearances	
			Radial C _s	Axial C _a ¹⁾		Radial max	Axial max
		lb/g	lbf/kN		lbf-in/Nm	in/mm	
03	3/16	0.02	4 270	500	0.06	0.0010	0.0035
		9,1	18,99	2,22	0,007	0,0254	0,0889
04	1/4	0.02	5 910	750	0.06	0.0010	0.0035
		9,1	26,29	3,34	0,007	0,0254	0,0889
05	5/16	0.03	8 110	1 000	0.06	0.0010	0.0035
		13,6	36,08	4,45	0,007	0,0254	0,0889
06	3/8	0.04	9 714	1 400	0.08	0.0012	0.0040
		18,1	43,21	6,23	0,009	0,0305	0,1016
08	1/2	0.07	16 360	2 700	0.08	0.0012	0.0040
		31,8	72,77	12,01	0,009	0,0305	0,1016
10	5/8	0.12	27 540	4 750	0.12	0.0015	0.0045
		54,4	122,50	21,13	0,014	0,0381	0,1143
12	3/4	0.21	41 400	6 900	0.12	0.0015	0.0045
		95,3	184,16	30,69	0,014	0,0381	0,1143
14	7/8	0.27	50 990	7 900	0.18	0.0018	0.0055
		122,5	226,81	35,14	0,020	0,0457	0,1397
16	1	0.39	66 730	10 700	0.25	0.0020	0.0060
		176,9	296,83	47,60	0,028	0,0508	0,1524

¹⁾ These values can be limited by the unstaking load (contact SKF for more information)

2.25 Self-lubricating narrow (inch dimensions)

SN... bore code **03** to **10**

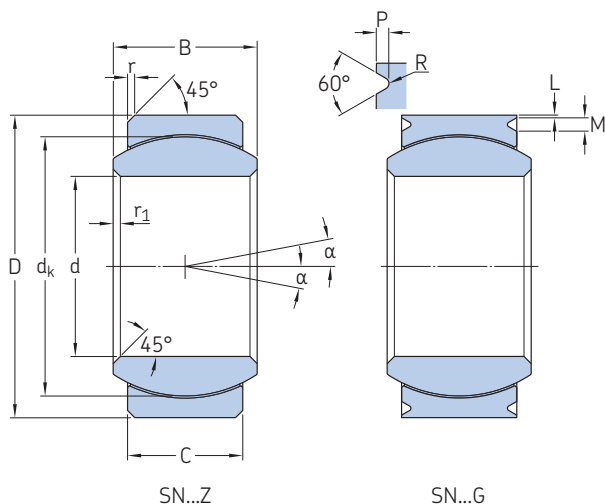

Technical specification	AS 8942
Product standards	NSA 8134 (chamfered outer ring) NSA 8136 (grooved outer ring)
Materials	
Liner	X1
Inner ring	Corrosion-resistant steel 440C
Outer ring	Corrosion-resistant steel 17-4PH

Nominal bore code	L	M
	+0.010/0	+0.010/0
	+0,254/0	+0,254/0
-	in/mm	
≤ 04	0.010/0,254	0.035/0,889
05 to 07	0.020/0,508	0.045/1,143
≥ 08	0.020/0,508	0.070/1,778

Dimensions

Nominal bore code	Size	Dimensions										
		d	D	C	B	dk	r	r ₁	P	R	α	
		0/-0,0005 0/-0,0127	0/-0,0005 0/-0,0127	0/-0,010 0/-0,254	0/-0,002 0/-0,051	≈	0/-0,010 0/-0,254	+0,010/0 +0,254/0	+0,015/0 +0,381/0	+0,010/0 +0,254/0		
-		in/mm										°
03	3/16	0.1900 4,8260	0.5625 14,2875	0.223 5,664	0.281 7,137	0.437 11,100	0.020 0,508	0.005 0,127	0.015 0,381	0.005 0,127	10	
04	1/4	0.2500 6,3500	0.6562 16,6675	0.255 6,477	0.343 8,712	0.500 12,703	0.020 0,508	0.005 0,127	0.015 0,381	0.005 0,127	12	
05	5/16	0.3125 7,9375	0.7500 19,0500	0.286 7,264	0.375 9,525	0.593 15,062	0.025 0,635	0.005 0,127	0.025 0,635	0.005 0,127	11	
06	3/8	0.3750 9,5250	0.8125 20,6375	0.317 8,052	0.406 10,312	0.625 15,875	0.030 0,762	0.005 0,127	0.025 0,635	0.010 0,254	10	
07	7/16	0.4375 11,1125	0.9062 23,0175	0.348 8,839	0.437 11,100	0.687 17,450	0.030 0,762	0.005 0,127	0.025 0,635	0.010 0,254	9	
08	1/2	0.5000 12,7000	1.0000 25,4000	0.395 10,033	0.500 12,700	0.781 19,837	0.030 0,762	0.005 0,127	0.045 1,143	0.010 0,254	9°30'	
09	9/16	0.5625 14,2875	1.0937 27,7800	0.442 11,227	0.562 14,275	0.875 22,225	0.030 0,762	0.005 0,127	0.045 1,143	0.010 0,254	10	
10	5/8	0.6250 15,8750	1.1875 30,1625	0.505 12,827	0.625 15,875	1.000 25,400	0.030 0,762	0.005 0,127	0.045 1,143	0.010 0,254	8°30'	



Designation system

Examples: SN04GXC Y2
SN10Z

SN 04 G X C Y2

Basic designation

Bore code (multiples of 1/16 inch)

Chamfer and groove

Z Chamfered outer ring
G Grooved outer ring

Starting torque

No code Standard
X²⁾ Reduced

Surface treatment of outer ring

No code Not plated
C¹⁾ Cadmium plated external dimensions
J¹⁾ Zinc-nickel plated external dimensions

Oversize

No code Standard outer diameter size
Y1¹⁾ 0.005 in/0,127 mm oversized outer diameter
Y2¹⁾ 0.010 in/0,254 mm oversized outer diameter
Y3¹⁾ 0.015 in/0,381 mm oversized outer diameter
Y4¹⁾ 0.020 in/0,508 mm oversized outer diameter

¹⁾ SKF option

²⁾ Available only for bore code ≤ 16

Loads and torques

Nominal bore code	Size	Mass ≈	Static limit loads		Radial dynamic load C ₂₅	Starting torque	
			Radial C _s	Axial C _a ⁴⁾		Standard	Reduced starting torque ³⁾ Max
		lb/g	lbf/kN		lbf-in/Nm		
03	3/16	0.02	3 975	500	1 500	0.5/3	0.5
		9,1	17,68	2,22	6,67	0,06/0,34	0,06
04	1/4	0.02	6 040	750	2 320	1.0/5.0	1.0
		9,1	26,87	3,34	10,32	0,11/0,56	0,11
05	5/16	0.03	8 750	1 000	3 430	1.0/5.0	1.0
		13,6	38,92	4,45	15,25	0,11/0,56	0,11
06	3/8	0.04	10 540	1 400	4 200	1.0/5.0	1.0
		18,1	46,88	6,23	18,68	0,11/0,56	0,11
07	7/16	0.05	13 200	1 800	5 700	1.0/5.0	1.0
		22,7	58,72	8,01	25,35	0,11/0,56	0,11
08	1/2	0.07	17 900	2 700	7 900	1.0/5.0	1.0
		31,8	79,62	12,01	35,14	0,11/0,56	0,11
09	9/16	0.09	23 200	3 680	10 300	1.0/5.0	1.0
		40,8	103,20	16,37	45,81	0,11/0,56	0,11
10	5/8	0.12	30 500	4 750	13 400	1.0/5.0	1.0
		54,4	135,67	21,13	59,6	0,11/0,56	0,11

³⁾ The minimum starting torque is limited by zero radial and axial internal clearance

⁴⁾ These values can be limited by the unstaking load (contact SKF for more information)

2.25 Self-lubricating narrow (inch dimensions)

SN... bore code 12 to 32

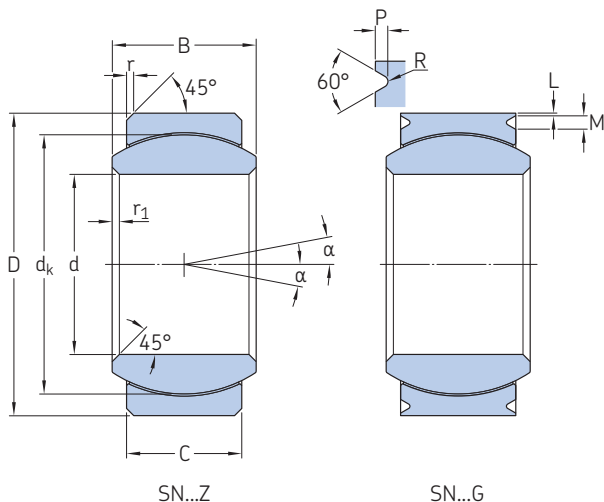

Technical specification	AS 8942
Product standards	NSA 8134 (chamfered outer ring) NSA 8136 (grooved outer ring)
Materials	
Liner	X1
Inner ring	Corrosion-resistant steel 440C
Outer ring	Corrosion-resistant steel 17-4PH

Nominal bore code	L	M
	+0.010/0	+0.010/0
	+0,254/0	+0,254/0
-	in/mm	
≤ 04	0.010/0,254	0.035/0,889
05 to 07	0.020/0,508	0.045/1,143
≥ 08	0.020/0,508	0.070/1,778

Dimensions

Nominal bore code	Size	Dimensions									
		d	D	C	B	dk	r	r1	P	R	α
		0/-0,0005	0/-0,0005	0/-0,010	0/-0,002	≈	0/-0,010	+0,010/0	+0,015/0	0/0,010	α
		0/-0,0127	0/-0,0127	0/-0,254	0/-0,051		0/-0,254	+0,254/0	+0,381/0	0/0,254	°
-		in/mm									
12	3/4	0.7500	1.4375	0.598	0.750	1.250	0.030	0.005	0.045	0.010	8°30'
		19,0500	36,5125	15,189	19,050	31,750	0,762	0,127	1,143	0,254	
14	7/8	0.8750	1.5625	0.708	0.875	1.375	0.040	0.005	0.045	0.010	9
		22,2250	39,6875	17,983	22,225	34,925	1,016	0,127	1,143	0,254	
16	1	1.0000	1.7500	0.802	1.000	1.562	0.040	0.005	0.045	0.010	9°30'
		25,4000	44,4500	20,371	25,400	39,675	1,016	0,127	1,143	0,254	
20	1 1/4	1.2500	2.0000	0.947	1.093	1.812	0.040	0.005	0.045	0.010	6
		31,7500	50,8000	24,054	27,762	46,020	1,016	0,127	1,143	0,254	
24¹⁾	1 1/2	1.5000	2.4375	1.135	1.312	2.250	0.040	0.005	0.045	0.010	6
		38,1000	61,9125	28,829	33,325	57,150	1,016	0,127	1,143	0,254	
28¹⁾	1 3/4	1.7500	2.8125	1.322	1.531	2.625	0.040	0.005	0.045	0.010	6
		44,4500	71,4375	33,579	38,887	66,675	1,016	0,127	1,143	0,254	
28PR	1 3/4	1.7500	2.8750	1.000	1.125	2.592	0.040	0.005	0.045	0.010	4
		44,4500	73,0250	25,400	28,575	65,834	1,016	0,127	1,143	0,254	
32¹⁾	2	2.0000	3.1875	1.510	1.750	3.000	0.040	0.005	0.045	0.010	6
		50,8000	80,9625	38,354	44,450	76,200	1,016	0,127	1,143	0,254	

¹⁾ SKF option



Designation system

Examples: SN04GXC¹Y2
SN10Z

SN 04 G X C Y2

Basic designation

Bore code (multiples of 1/16 inch)

Chamfer and groove

Z Chamfered outer ring
G Grooved outer ring

Starting torque

No code Standard
X²⁾ Reduced

Surface treatment of outer ring

No code Not plated
C¹⁾ Cadmium plated external dimensions
J¹⁾ Zinc-nickel plated external dimensions

Oversize

No code Standard outer diameter size
Y1¹⁾ 0.005 in/0,127 mm oversized outer diameter
Y2¹⁾ 0.010 in/0,254 mm oversized outer diameter
Y3¹⁾ 0.015 in/0,381 mm oversized outer diameter
Y4¹⁾ 0.020 in/0,508 mm oversized outer diameter

¹⁾ SKF option

²⁾ Available only for bore code ≤ 16

Loads and torques

Nominal bore code	Size	Mass ≈	Static limit loads		Radial dynamic load C ₂₅	Starting torque Standard	Reduced starting torque ³⁾ Max
			Radial C _s	Axial C _a ⁴⁾			
		lb/g	lbf/kN		lbf-in/Nm		
12	3/4	0.21	46 400	6 749	19 700	1.0/5.0	1.0
		95,3	206,40	30,02	87,63	0,11/0,56	0,11
14	7/8	0.27	62 200	9 350	26 100	2.0/8.0	2.0
		122,5	276,68	41,59	116,09	0,23/0,90	0,23
16	1	0.39	82 200	12 160	34 100	2.0/8.0	2.0
		176,9	365,64	54,09	151,68	0,23/0,90	0,23
20	1 1/4	0.53	93 180	17 535	45 022	3.5/13.3	–
		240,4	414,49	78,00	200,27	0,4/1,5	–
24 ¹⁾	1 1/2	0.96	141 060	24 000	71.607	3.5/13.3	–
		435,4	627,47	106,76	318,52	0,4/1,5	–
28 ¹⁾	1 3/4	1.48	194 040	33 750	72.406	3.5/13.3	–
		671,3	863,13	150,13	318,08	0,4/1,5	–
28PR	1 3/4	1.20	286 478	19 906	65 120	3.5/13.3	–
		545,0	1 274,32	88,55	289,67	0,4/1,5	–
32 ¹⁾	2	2.10	255 600	44 500	129.751	3.5/13.3	–
		952,5	1 136,97	197,95	577,16	0,4/1,5	–

³⁾ The minimum starting torque is limited by zero radial and axial internal clearance

⁴⁾ These values can be limited by the unstaking load (contact SKF for more information)

2.26 Self-lubricating narrow (inch dimensions)

NAS.. (XRE..., 11HN.. or 11BN..) bore code **3 to 10**

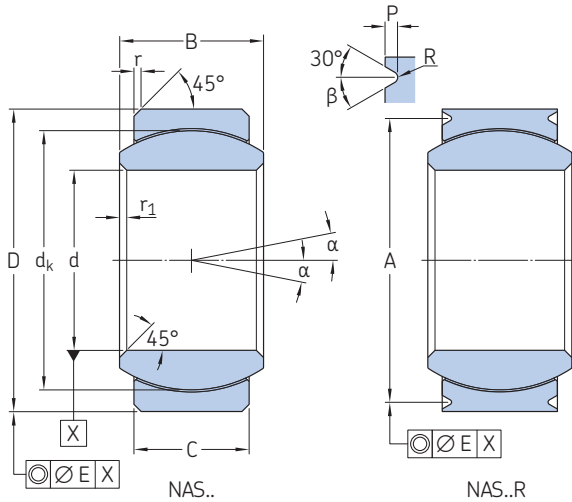

Technical specification	AS 81820
Product standards	AS 14101 (grooved outer ring) AS 14104 (chamfered outer ring)
Materials	
Liner	X1
Inner ring	Corrosion-resistant steel 440C or PH13.8
Outer ring	Corrosion-resistant steel 17-4PH

Nominal bore code	β	E
-	$^{\circ}$	in/mm
≤ 4	20	0.005/0,127
≥ 5	30	0.005/0,127

Dimensions

Nominal bore code	Size	Dimensions											
		d	D	C	B	d_k	r_1	r	A	P	R	α^4	
		0/-0.0005 0/-0,0127	0/-0.0005 0/-0,0127	± 0.005 $\pm 0,127$	0/-0.002 0/-0,051	\approx	± 0.005 $\pm 0,127$	+0.010/0 +0,254/0	0/-0.008 0/-0,203	0/-0.010 0/-0,254			
-		in/mm											$^{\circ}$
3	3/16	0.1900 4,826	0.5625 14,288	0.218 5,537	0.281 7,137	0.406 10,312	0.010 0,254	0.010 0,254	0.500 12,700	0.025 0,635	0.005/0.010 0,127/0,254	10	
4	1/4	0.2500 6,350	0.6562 16,667	0.250 6,350	0.343 8,712	0.500 12,704	0.010 0,254	0.010 0,254	0.594 15,088	0.025 0,635	0.005/0.010 0,127/0,254	10	
5	5/16	0.3125 7,938	0.7500 19,050	0.281 7,137	0.375 9,525	0.562 14,283	0.010 0,254	0.010 0,254	0.660 16,764	0.035 0,889	0.005/0.010 0,127/0,254	10	
6	3/8	0.3750 9,525	0.8125 20,638	0.312 7,925	0.406 10,312	0.625 15,872	0.010 0,254	0.020 0,508	0.712 18,085	0.035 0,889	0.010/0.017 0,254/0,432	9	
7	7/16	0.4375 11,113	0.9062 23,017	0.343 8,712	0.437 11,100	0.687 17,448	0.010 0,254	0.020 0,508	0.806 20,472	0.035 0,889	0.010/0.017 0,254/0,432	8	
8	1/2	0.5000 12,700	1.0000 25,400	0.390 9,906	0.500 12,700	0.781 19,838	0.010 0,254	0.020 0,508	0.876 22,250	0.055 1,397	0.010/0.017 0,254/0,432	8	
9	9/16	0.5625 14,288	1.0937 27,780	0.437 11,100	0.562 14,275	0.874 22,212	0.010 0,254	0.020 0,508	0.970 24,638	0.055 1,397	0.010/0.017 0,254/0,432	8	
10	5/8	0.6250 15,875	1.1875 30,163	0.500 12,700	0.625 15,875	0.968 24,584	0.010 0,254	0.020 0,508	1.063 27,000	0.055 1,397	0.010/0.017 0,254/0,432	8	

Loads and torque

Nominal bore code	Size	Mass \approx	Static limit loads		Radial dynamic loads C ₂₅	Starting torque ⁴⁾		
			Radial C _s	Axial C _a ²⁾		Standard	Standard, SKF precision	Reduced ³⁾ max
-		lb/g	lbf/kN			lbf-in/Nm		
3	3/16	0.02 9	3 975 17,69	150 0,67	1 500 6,67	0.25/5 0,03/0,56	0.5/3 0,06/0,34	0.5 0,06
4	1/4	0.02 9	6 040 26,88	430 1,91	3 320 14,77	0.25/5 0,03/0,56	1/5 0,11/0,56	0.5 0,06
5	5/16	0.03 14	8 750 38,94	700 3,11	5 460 24,30	0.25/8 0,03/0,90	1/5 0,11/0,56	1 0,11
6	3/8	0.04 18	10 540 46,90	1 100 4,89	6 600 29,37	0.25/8 0,03/0,90	1/5 0,11/0,56	1 0,11
7	7/16	0.05 22	13 200 58,74	1 400 6,23	8 050 35,82	0.25/8 0,03/0,90	1/5 0,11/0,56	1 0,11
8	1/2	0.07 31	17 900 79,65	2 100 9,34	10 400 46,28	0.25/8 0,03/0,90	1/5 0,11/0,56	1 0,11
9	9/16	0.09 40	23 200 103,24	3 680 16,38	13 000 57,85	0.25/8 0,03/0,90	1/5 0,11/0,56	1 0,11
10	5/8	0.12 54	30 500 135,72	4 720 21,00	16 450 73,20	0.25/8 0,03/0,90	1/5 0,11/0,56	1 0,11

1) Parts are delivered and marked with SKF standard XRE..., 11HN.. (inner ring spherical surface coated) or 11BN.. references.

2) These values can be limited by the unstaking load (contact SKF for more information)

4) Values are given for non protected bearings. For sealed and shielded bearings, refer to page 149



Cross-reference designation system to XRE.., 11HN.. or 11BN..

Examples:	Z	E	NAS	12	R	X	TT	F	Y2
ZNAS12RXTTFY2									
NAS 3PPD									
Surface treatment of outer ring									
No code									
SZ									
Z									
Inner ring material									
No code									
E									
Basic designation									
Bore code (multiples of 1/16 inch)									
Chamfer and groove									
No code									
R									
Starting torque									
No code									
XS¹⁾									
X									
Shield and seal									
No code									
TT²⁾									
PP²⁾									
Material and surface treatment of inner ring code									
No code									
F¹⁾									
D¹⁾									
K^{1) 3)}									
N^{1) 3)}									
H^{1) 3)}									
Oversize									
No code									
Y2									
Y4									

1) SKF option

2) SKF option, only available for $d \geq 5$

3) For sealed (code TT) or shielded (code PP) bearings with XLHP, XLNT or XL coated sphere, contact SKF to check for availability and technical suitability

3) If starting torque is ≤ 0.1 lbf-in (0,01 Nm), maximum internal clearance must be:

Nominal bore code	Maximum radial clearance	Maximum axial clearance
-	in/mm	
≤ 12	0.0007/0,0178	0.0028/0,0711
≥ 14	0.0010/0,0254	0.0040/0,1016

2.26 Self-lubricating narrow (inch dimensions)

NAS.. (XRE..., 11HN.. or 11BN..)² bore code **12** to **32**

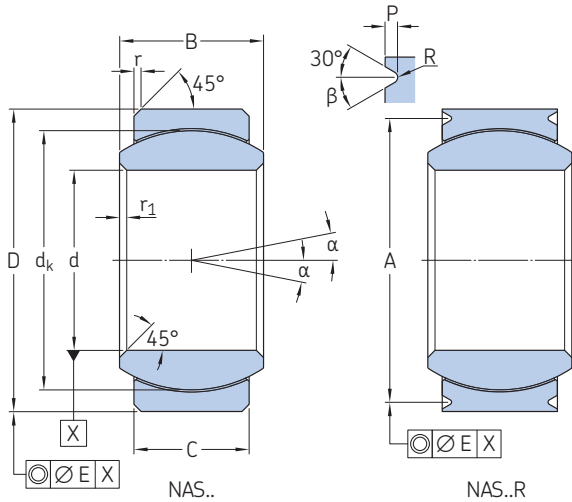

Technical specification	AS 81820
Product standards	AS 14101 (grooved outer ring) AS 14104 (chamfered outer ring)
Materials	
Liner	X1
Inner ring	Corrosion-resistant steel 440C or PH13.8
Outer ring	Corrosion-resistant steel 17-4PH

Nominal bore code	β	E
-	$^{\circ}$	in/mm
≤ 4	20	0.005/0,127
≥ 5	30	0.005/0,127

Dimensions

Nominal bore code	Size	Dimensions										α^4
		d	D	C	B	d_k	r_1	r	A	P	R	
		0/-0.0005 0/-0,0127	0/-0.0005 0/-0,0127	± 0.005 $\pm 0,127$	0/-0.002 0/-0,051	\approx	± 0.005 $\pm 0,127$	+0.010/0 +0,254/0	0/-0.008 0/-0,203	0/-0.010 0/-0,254		
-		in/mm										$^{\circ}$
12	3/4	0.7500 19,050	1.4375 36,513	0.593 15,062	0.750 19,050	1.187 30,149	0.010 0,254	0.030 0,762	1.313 33,350	0.055 1,397	0.010/0.017 0,254/0,432	8
14	7/8	0.8750 22,225	1.5625 39,688	0.703 17,856	0.875 22,225	1.314 33,370	0.010 0,254	0.030 0,762	1.438 36,525	0.055 1,397	0.010/0.017 0,254/0,432	8
16	1	1.0000 25,400	1.7500 44,450	0.797 20,244	1.000 25,400	1.500 38,099	0.010 0,254	0.030 0,762	1.626 41,300	0.055 1,397	0.010/0.017 0,254/0,432	9
20¹⁾	1 1/4	1.2500 31,750	2.0000 50,800	0.937 23,800	1.093 27,762	1.812 46,020	0.010 0,254	0.030 0,762	1.878 47,701	0.060 1,524	0.010/0.020 0,254/0,508	6
24¹⁾	1 1/2	1.5000 38,100	2.4375 61,913	1.135 28,830	1.312 33,325	2.284 58,022	0.010 0,254	0.030 0,762	2.317 58,850	0.060 1,524	0.010/0.020 0,254/0,508	6
28¹⁾	1 3/4	1.7500 44,450	2.8750 73,025	1.000 25,400	1.125 28,575	2.517 63,941	0.010 0,254	0.030 0,762	2.753 69,930	0.060 1,524	0.010/0.020 0,254/0,508	4
32¹⁾	2	2.0000 50,800	3.1875 80,963	1.510 38,354	1.750 44,450	3.000 76,200	0.010 0,254	0.040 1,016	3.064 77,826	0.060 1,524	0.010/0.020 0,254/0,508	6

Loads and torque

Nominal bore code	Size	Mass \approx	Static limit loads		Radial dynamic load C ₂₅	Starting torque ⁴⁾		
			Radial C _s	Axial C _a ³⁾		Standard	Standard, SKF precision	Reduced ⁴⁾ max
-		lb/g	lbf/kN			lbf-in/Nm		
12	3/4	0.21 95	46 400 206,48	6 750 30,03	23 600 105,02	0.25/8 0,03/0,90	1/5 0,11/0,56	1 0,11
14	7/8	0.27 122	62 200 276,79	9 350 41,60	30 250 134,61	0.25/12 0,03/1,36	2/8 0,23/0,9	2 0,23
16	1	0.39 176	82 200 365,79	12 160 54,11	38 000 169,10	0.25/12 0,03/1,36	2/8 0,23/0,9	2 0,23
20¹⁾	1 1/4	0.53 240	91 011 405,00	17 528 78,00	45 025 200,27	2/20 0,23/2,26	2.5/13 0,28/1,47	2.2 0,25
24¹⁾	1 1/2	0.89 405	139 363 619,39	26 339 117,06	72 410 322,08	2/20 0,23/2,26	2.5/15.5 0,28/1,75	2.5 0,28
28¹⁾	1 3/4	1.20 545	127 432 567,07	19 924 88,55	65 124 289,67	10/35 1,3/3,9	4.5/19 0,5/2,15	4.5 0,5
32¹⁾	2	2.10 953	298 200 1 326,46	51 905 230,88	144 579 643,12	10/35 1,3/3,9	10.0/35.0 1,3/3,9	4.5 0,5

¹⁾ SKF option ²⁾ Parts are delivered and marked with SKF standard XRE..., 11HN.. (inner ring spherical surface coated) or 11BN.. references.

³⁾ These values can be limited by the unstaking load (contact SKF for more information)

⁴⁾ Values are given for non protected bearings. For sealed and shielded bearings, refer to page 149



Cross-reference designation system to XRE.., 11HN.. or 11BN..

Examples:	Z	E	NAS	12	R	X	TT	F	Y2
ZNAS12RXTTFY2 NAS 3PPD									
Surface treatment of outer ring									
No code									
SZ									
Z									
Inner ring material									
No code									
E									
Basic designation									
Bore code (multiples of 1/16 inch)									
Chamfer and groove									
No code									
R									
Starting torque									
No code									
XS¹⁾									
X									
Shield and seal									
No code									
TT²⁾									
PP²⁾									
Material and surface treatment of inner ring code									
No code									
F¹⁾									
D¹⁾									
K^{1) 3)}									
N^{1) 3)}									
H^{1) 3)}									
Oversize									
No code									
Y2									
Y4									

1) SKF option

2) SKF option, only available for $d \geq 5$

3) For sealed (code TT) or shielded (code PP) bearings with XLHP, XLNT or XL coated sphere, contact SKF to check for availability and technical suitability

4) If starting torque is ≤ 0.1 lbf-in (0,01 Nm), maximum internal clearance must be:

Nominal bore code	Maximum radial clearance	Maximum axial clearance
-	in/mm	
≤ 12	0.0007/0,0178	0.0028/0,0711
≥ 14	0.0010/0,0254	0.0040/0,1016

2.27 Self-lubricating narrow (inch dimensions)

NAS..A (XRE..A., 11LHN.. or 11LBN..)² bore code 3 to 9

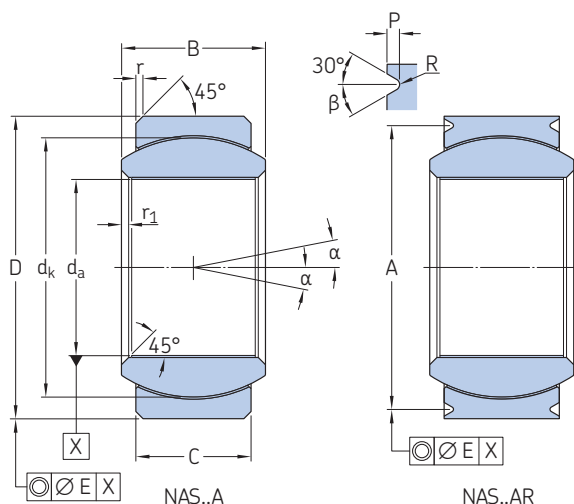

Technical specification	AS 81820
Product standards	AS 81820/1 (lined bore and grooved outer ring) AS 81820/4 (lined bore and chamfered outer ring)
Materials	
Liner	X1
Inner ring	Passivated corrosion-resistant steel 440C or PH13.8
Outer ring	Corrosion-resistant steel 17-4PH

Nominal bore code	β	E
-	$^{\circ}$	in/mm
≤ 5	20°	0.006/0,152
≥ 6	30°	0.006/0,152

Dimensions

Nominal bore code	Size	Dimensions										
		d_3	D	C	B	d_k	r_1	r	A	P	R	α^4
-	-	0/-0,0010 0/-0,0254	0/-0,0005 0/-0,0127	$\pm 0,005$ $\pm 0,127$	0/-0,002 0/-0,051	\approx	max	+0,010/0 +0,254/0	0/-0,008 0/-0,203	0/-0,010 0/-0,254		$^{\circ}$
-	-	in/mm										$^{\circ}$
3 ¹⁾	3/16	0.1910 4,851	0.5625 14,288	0.218 5,537	0.281 7,137	0.406 10,312	0.005 0,127	0.010 0,254	0.500 12,700	0.025 0,635	0.005/0.010 0,127/0,254	10
4	1/4	0.2510 6,375	0.6562 16,667	0.250 6,350	0.343 8,712	0.500 12,704	0.005 0,127	0.010 0,254	0.594 15,088	0.025 0,635	0.005/0.010 0,127/0,254	10
5	5/16	0.3135 7,963	0.7500 19,050	0.281 7,137	0.375 9,525	0.562 14,283	0.005 0,127	0.010 0,254	0.660 16,764	0.035 0,889	0.005/0.010 0,127/0,254	10
6	3/8	0.3760 9,550	0.8125 20,638	0.312 7,925	0.406 10,312	0.625 15,872	0.005 0,127	0.020 0,508	0.712 18,085	0.035 0,889	0.010/0.017 0,254/0,432	9
7	7/16	0.4385 11,138	0.9062 23,017	0.343 8,712	0.437 11,100	0.687 17,448	0.005 0,127	0.020 0,508	0.806 20,472	0.035 0,889	0.010/0.017 0,254/0,432	8
8	1/2	0.5010 12,725	1.0000 25,400	0.390 9,906	0.500 12,700	0.781 19,838	0.005 0,127	0.020 0,508	0.876 22,250	0.055 1,397	0.010/0.017 0,254/0,432	8
9	9/16	0.5635 14,313	1.0937 27,780	0.437 11,100	0.562 14,275	0.874 22,212	0.005 0,127	0.020 0,508	0.970 24,638	0.055 1,397	0.010/0.017 0,254/0,432	8

Loads and torque

Nominal bore code	Size	Mass \approx	Static limit loads		Radial dynamic load C ₂₅	Starting torque ⁴⁾		
			Radial C _s	Axial C _a ³⁾		Standard	Standard, SKF precision	Reduced ⁴⁾ Max
-	-	lb/g	lbf/kN			lbf-in/Nm		
3 ¹⁾	3/16	0.02 9	3 975 17,69	150 0,67	1 500 6,67	1/5 0,11/0,56	1/3 0,11/0,34	0.5 0,06
4	1/4	0.02 9	6 040 26,88	430 1,91	3 320 14,77	1/15 0,11/1,69	1/5 0,11/0,56	0.5 0,06
5	5/16	0.03 14	8 750 38,94	700 3,11	5 460 24,30	1/15 0,11/1,69	1/5 0,11/0,56	1 0,11
6	3/8	0.04 18	10 540 46,90	1 100 4,89	6 600 29,37	1/15 0,11/1,69	1/5 0,11/0,56	1 0,11
7	7/16	0.05 22	13 200 58,74	1 400 6,23	8 050 35,82	1/15 0,11/1,69	1/5 0,11/0,56	1 0,11
8	1/2	0.07 31	17 900 79,65	2 100 9,34	10 400 46,28	1/15 0,11/1,69	1/5 0,11/0,56	1 0,11
9	9/16	0.09 40	23 200 103,24	3 680 16,38	13 000 57,85	1/15 0,11/1,69	1/5 0,11/0,56	1 0,11

1) SKF option 2) Parts are delivered and marked with SKF standard XRE..A., 11LHN (inner ring spherical surface coated) or 11LBN.. references.

3) These values can be limited by the unstaking load (contact SKF for more information)

4) Values are given for non protected bearings. For sealed and shielded bearings, refer to page 149

Cross-reference designation system to XRE..A, 11LHN.. or 11LBN..

Examples:	Z	E	NAS	12	A	R	X	TT	F	Y2
ZNAS12ARXTTFY2										
NAS 3APPD										
Surface treatment of outer ring	_____									
No code	Not plated									
Z	Cadmium plated external dimensions									
SZ	Zinc-nickel plated external dimensions									
Inner ring material	_____									
No code	440C									
E	PH13.8									
Basic designation	_____									
Bore code (multiples of 1/16 inch)	_____									
Chamfer and groove	_____									
No code	Chamfered outer ring									
R	Grooved outer ring									
Starting torque	_____									
No code	Standard									
XS¹⁾	Standard, SKF precision									
X	Reduced									
Shield and seal	_____									
No code	No shield and seal									
TT²⁾	Sealed									
PP²⁾	Shielded									
Material and surface treatment of inner ring code	_____									
No code	Passivated inner ring									
F¹⁾	Chromium plated sphere									
D¹⁾	XCR plating on sphere (chromium 6 free replacement to chromium plating)									
K^{1) 3)}	XLHP coated sphere									
N^{1) 3)}	XLNT coated sphere									
H^{1) 3)}	XL coated sphere									
Oversize	_____									
No code	Standard outer diameter size									
Y2	0.010 in/0,254 mm oversized outer diameter									
Y4	0.020 in/0,508 mm oversized outer diameter									

1) SKF option

2) SKF option, only available for $d \geq 5$

3) For sealed (code TT) or shielded (code PP) bearings with XLHP, XLNT or XL coated sphere, contact SKF to check for availability and technical suitability

4) If starting torque is ≤ 0.1 lbf-in (0,01 Nm), maximum internal clearance must be:

Nominal bore code	Maximum radial clearance	Maximum axial clearance
-	in/mm	
≤ 12	0,0007/0,0178	0,0028/0,0711
≥ 14	0,0010/0,0254	0,0040/0,1016

2.27 Self-lubricating narrow (inch dimensions)

NAS..A (XRE..A., 11LHN.. or 11LBN..)² bore code **10** to **32**

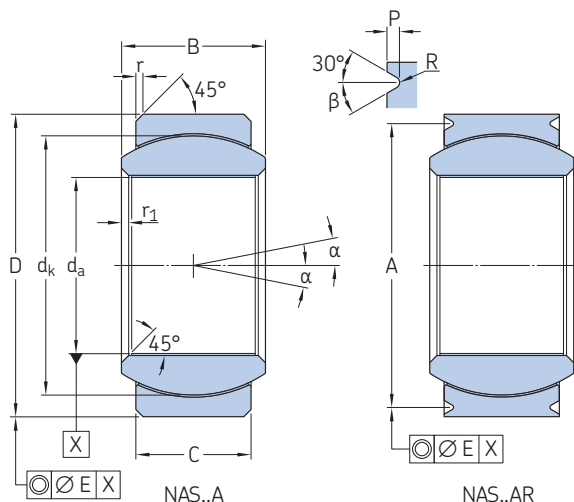

Technical specification AS 81820

Product standards AS 81820/1 (lined bore and grooved outer ring)
AS 81820/4 (lined bore and chamfered outer ring)

Materials
Liner X1
Inner ring Passivated corrosion-resistant steel 440C or PH13.8
Outer ring Corrosion-resistant steel 17-4PH

Nominal bore code	β	E
-	$^{\circ}$	in/mm
≤ 5	20°	0.006/0,152
≥ 6	30°	0.006/0,152

Dimensions

Nominal bore code	Size	Dimensions										
		d_a	D	C	B	d_k	r_1 max	r	A	P	R	α^4
-		0/-0,0010 0/-0,0254	0/-0,0005 0/-0,0127	$\pm 0,005$ $\pm 0,127$	0/-0,002 0/-0,051	\approx		+0,010/0 +0,254/0	0/-0,008 0/-0,203	0/-0,010 0/-0,254		$^{\circ}$
-		in/mm										
10	5/8	0,6260 15,900	1,1875 30,163	0,500 12,700	0,625 15,875	0,968 24,584	0,005 0,127	0,020 0,508	1,063 27,000	0,055 1,397	0,010/0,017 0,254/0,432	8
12	3/4	0,7510 19,075	1,4375 36,513	0,593 15,062	0,750 19,050	1,187 30,149	0,005 0,127	0,030 0,762	1,313 33,350	0,055 1,397	0,010/0,017 0,254/0,432	8
14	7/8	0,8760 22,250	1,5625 39,688	0,703 17,856	0,875 22,225	1,314 33,370	0,005 0,127	0,030 0,762	1,438 36,525	0,055 1,397	0,010/0,017 0,254/0,432	8
16	1	1,0010 25,425	1,7500 44,450	0,797 20,244	1,000 25,400	1,500 38,099	0,005 0,127	0,030 0,762	1,626 41,300	0,055 1,397	0,010/0,017 0,254/0,432	9
20¹⁾	1 1/4	1,2510 31,775	2,0000 50,800	0,937 23,800	1,093 27,762	1,812 46,020	0,005 0,127	0,030 0,762	1,878 47,701	0,060 1,524	0,010/0,020 0,254/0,508	6
24¹⁾	1 1/2	1,5010 38,125	2,4375 61,913	1,135 28,830	1,312 33,325	2,284 58,022	0,005 0,127	0,030 0,762	2,317 58,850	0,060 1,524	0,010/0,020 0,254/0,508	6
28¹⁾	1 3/4	1,7510 44,475	2,8750 73,025	1,000 25,400	1,125 28,575	2,517 63,941	0,005 0,127	0,030 0,762	2,753 69,930	0,060 1,524	0,010/0,020 0,254/0,508	4
32¹⁾	2	2,0010 50,825	3,1875 80,963	1,510 38,354	1,750 44,450	3,000 76,200	0,005 0,127	0,040 1,016	3,064 77,826	0,060 1,524	0,010/0,020 0,254/0,508	6

Loads and torque

Nominal bore code	Size	Mass \approx	Static limit loads		Radial dynamic load C ₂₅	Starting torque ⁴⁾		
			Radial C _s	Axial C _a ³⁾		Standard	Standard, SKF precision	Reduced ⁴⁾ Max
-		lb/g	lbf/kN			lbf-in/Nm		
10	5/8	0,12 54	30 500 135,72	4 720 21,00	16 450 73,20	1/15 0,11/1,69	1/5 0,11/0,56	1 0,11
12	3/4	0,21 95	46 400 206,48	6 750 30,03	23 600 105,02	1/15 0,11/1,69	1/5 0,11/0,56	1 0,11
14	7/8	0,27 122	62 200 276,79	9 350 41,60	30 250 134,61	1/25 0,11/2,82	2/8 0,23/0,9	2 0,23
16	1	0,39 176	82 200 365,79	12 160 54,11	38 000 169,10	1/25 0,11/2,82	2/8 0,23/0,9	2 0,23
20¹⁾	1 1/4	0,53 240	91 011 405,00	17 528 78,00	45 025 200,27	2/20 0,23/2,26	2,5/13 0,28/1,47	2,2 0,25
24¹⁾	1 1/2	0,89 405	139 363 619,39	26 339 117,06	72 410 322,08	2/20 0,23/2,26	2,5/15,5 0,28/1,75	2,5 0,28
28¹⁾	1 3/4	1,20 545	127 432 567,07	19 924 88,55	65 124 289,67	10/35 1,3/3,9	4,5/19 0,5/2,15	4,5 0,5
32¹⁾	2	2,10 953	298 200 1 326,46	51 905 230,88	144 579 643,12	10/35 1,3/3,9	10,0/35,0 1,3/3,9	4,5 0,5

¹⁾ SKF option ²⁾ Parts are delivered and marked with SKF standard XRE..A., 11LHN (inner ring spherical surface coated) or 11LBN.. references.

³⁾ These values can be limited by the unstaking load (contact SKF for more information)

⁴⁾ Values are given for non protected bearings. For sealed and shielded bearings, refer to page 149



Cross-reference designation system to XRE..A, 11LHN.. or 11LBN..

Examples:	Z	E	NAS	12	A	R	X	TT	F	Y2
ZNAS12ARXTTFY2										
NAS 3APPD										
Surface treatment of outer ring	_____									
No code	Not plated									
Z	Cadmium plated external dimensions									
SZ	Zinc-nickel plated external dimensions									
Inner ring material	_____									
No code	440C									
E	PH13.8									
Basic designation	_____									
Bore code (multiples of 1/16 inch)	_____									
Chamfer and groove	_____									
No code	Chamfered outer ring									
R	Grooved outer ring									
Starting torque	_____									
No code	Standard									
XS¹⁾	Standard, SKF precision									
X	Reduced									
Shield and seal	_____									
No code	No shield and seal									
TT²⁾	Sealed									
PP²⁾	Shielded									
Material and surface treatment of inner ring code	_____									
No code	Passivated inner ring									
F¹⁾	Chromium plated sphere									
D¹⁾	XCR plating on sphere (chromium 6 free replacement to chromium plating)									
K^{1) 3)}	XLHP coated sphere									
N^{1) 3)}	XLNT coated sphere									
H^{1) 3)}	XL coated sphere									
Oversize	_____									
No code	Standard outer diameter size									
Y2	0.010 in/0,254 mm oversized outer diameter									
Y4	0.020 in/0,508 mm oversized outer diameter									

1) SKF option

2) SKF option, only available for $d \geq 5$

3) For sealed (code TT) or shielded (code PP) bearings with XLHP, XLNT or XL coated sphere, contact SKF to check for availability and technical suitability

4) If starting torque is ≤ 0.1 lbf-in (0,01 Nm), maximum internal clearance must be:

Nominal bore code	Maximum radial clearance	Maximum axial clearance
-	in/mm	
≤ 12	0,0007/0,0178	0,0028/0,0711
≥ 14	0,0010/0,0254	0,0040/0,1016

2.28 Self-lubricating wide (inch dimensions)

SW... bore code **03** to **10**

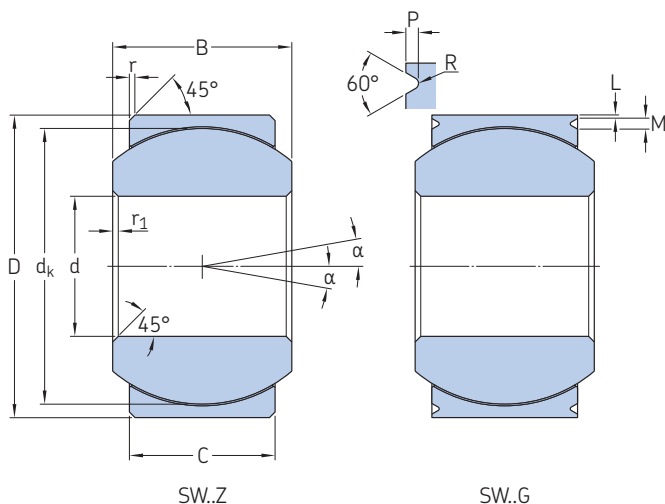

Technical specification	AS 8942
Product standards	NSA 8135 (chamfered outer ring) NSA 8137 (grooved outer ring)
Materials	
Liner	X1
Inner ring	Corrosion-resistant steel 440C
Outer ring	Corrosion-resistant steel 17-4PH

Nominal bore code	L	M
	+0.010/0	+0.010/0
	+0,254/0	+0,254/0

in/mm		
≤ 05	0.010/0,254	0.035/0,889
06 to 10	0.020/0,508	0.045/1,143
≥ 12	0.020/0,508	0.070/1,778

2.28

Dimensions

Nominal bore code	Size	Dimensions									
		d	D	C	B	dk	r	r ₁	P	R	α
		0/-0.0005	0/-0.0005	0/-0.010	0/-0.002	≈	+0.010/0	+0.010/0	+0.015/0	+0.010/0	
		0/-0,0127	0/-0,0127	0/-0,254	0/-0,051		+0,254/0	+0,254/0	+0,381/0	+0,254/0	
–		in/mm									°
03	3/16	0.1900 4,8260	0.6250 15,8750	0.332 8,433	0.437 11,100	0.531 13,487	0.015 0,381	0.005 0,127	0.015 0,381	0.005 0,127	17
04	1/4	0.2500 6,3500	0.6250 15,8750	0.332 8,433	0.437 11,100	0.531 13,487	0.015 0,381	0.005 0,127	0.015 0,381	0.005 0,127	17
05	5/16	0.3125 7,9375	0.6875 17,4625	0.322 8,179	0.437 11,100	0.593 15,062	0.015 0,381	0.005 0,127	0.015 0,381	0.005 0,127	14
06	3/8	0.3750 9,5250	0.8125 20,6375	0.411 10,439	0.500 12,700	0.687 17,450	0.015 0,381	0.005 0,127	0.025 0,635	0.010 0,254	10
07	7/16	0.4375 11,1125	0.9375 23,8125	0.447 11,354	0.562 14,275	0.781 19,837	0.015 0,381	0.005 0,127	0.025 0,635	0.010 0,254	12
08	1/2	0.5000 12,7000	1.0000 25,4000	0.510 12,954	0.625 15,875	0.875 22,225	0.020 0,508	0.005 0,127	0.025 0,635	0.010 0,254	9
09	9/16	0.5625 14,2875	1.1250 28,5750	0.541 13,741	0.687 17,450	1.000 25,400	0.020 0,508	0.005 0,127	0.025 0,635	0.010 0,254	11
10	5/8	0.6250 15,8750	1.1875 30,1625	0.572 14,529	0.750 19,050	1.062 26,975	0.020 0,508	0.005 0,127	0.025 0,635	0.010 0,254	12



Designation system

Examples: SW03GXCY2
SW10Z

SW 03 G X C Y2

Basic designation

Bore code (multiples of 1/16 inch)

Chamfer and groove

Z Chamfered outer ring
G Grooved outer ring

Starting torque

No code Standard
X Reduced

Surface treatment of outer ring

No code Not plated
C¹⁾ Cadmium plated external dimensions
J¹⁾ Zinc-nickel plated external dimensions

Oversize

No code Standard outer diameter size
Y1¹⁾ 0.005 in/0,127 mm oversized outer diameter
Y2¹⁾ 0.010 in/0,254 mm oversized outer diameter
Y3¹⁾ 0.015 in/0,381 mm oversized outer diameter
Y4¹⁾ 0.020 in/0,508 mm oversized outer diameter

¹⁾ SKF option

Loads and torque

Nominal bore code	Size	Mass ≈	Static limit loads		Radial limit load C ₂₅	Starting torque	
			Radial C _s	Axial C _a ²⁾		Standard	Reduced starting torque ³⁾ Max
		lb/g	lbf/kN		lbf-in/Nm		
03	3/16	0.03	9 000	1 770	3 770	1.0/5.0	0.5
		13,6	40,03	7,87	16,77	0,11/0,56	0,06
04	1/4	0.03	9 000	1 770	3 770	1.0/5.0	1.0
		13,6	40,03	7,87	16,77	0,11/0,56	0,11
05	5/16	0.03	9 400	1 640	4 645	1.0/5.0	1.0
		13,6	41,81	7,29	20,66	0,11/0,56	0,11
06	3/8	0.05	13 700	2 628	6 389	1.0/5.0	1.0
		22,7	60,94	11,69	28,42	0,11/0,56	0,11
07	7/16	0.08	20 700	3 650	9 388	1.0/5.0	1.0
		36,3	92,07	16,23	41,76	0,11/0,56	0,11
08	1/2	0.10	27 500	4 989	12 149	1.0/5.0	1.0
		45,4	122,32	22,19	54,04	0,11/0,56	0,11
09	9/16	0.14	34 400	5 368	14 979	1.0/5.0	1.0
		63,5	153,01	23,88	66,63	0,11/0,56	0,11
10	5/8	0.16	39 000	6 128	16 688	1.0/5.0	1.0
		72,6	173,48	27,26	74,23	0,11/0,56	0,11

²⁾ These values can be limited by the unstaking load (contact SKF for more information)

³⁾ The minimum starting torque is limited by zero radial and axial internal clearance

2.28 Self-lubricating wide (inch dimensions)

SW... bore code **12** to **32**

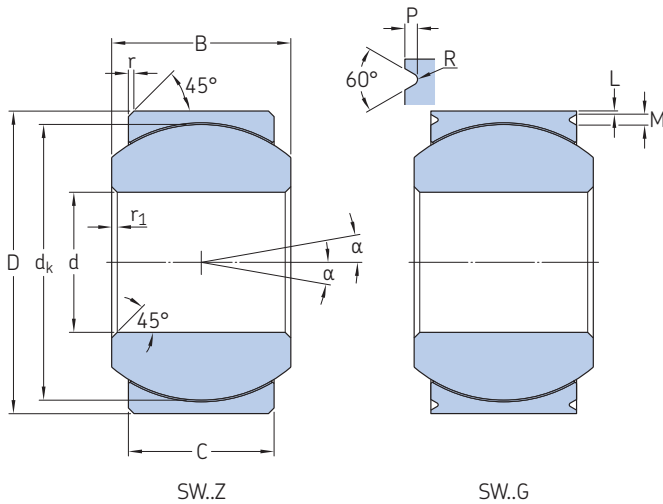

Technical specification	AS 8942
Product standards	NSA 8135 (chamfered outer ring) NSA 8137 (grooved outer ring)
Materials	
Liner	X1
Inner ring	Corrosion-resistant steel 440C
Outer ring	Corrosion-resistant steel 17-4PH

Nominal bore code	L	M
	+0,010/0 +0,254/0	+0,010/0 +0,254/0
- in/mm		
≤ 05	0,010/0,254	0,035/0,889
06 to 10	0,020/0,508	0,045/1,143
≥ 12	0,020/0,508	0,070/1,778

2.28

Dimensions

Nominal bore code	Size	Dimensions									
		d	D	C	B	dk	r	r1	P	R	α
		0/-0,0005 0/-0,0127	0/-0,0005 0/-0,0127	0/-0,010 0/-0,254	0/-0,002 0/-0,051	≈	+0,010/0 +0,254/0	+0,010/0 +0,254/0	+0,015/0 +0,381/0	+0,010/0 +0,254/0	
-		in/mm									
12	3/4	0,7500 19,0500	1,3750 34,9250	0,635 16,129	0,875 22,225	1,250 31,750	0,020 0,508	0,005 0,127	0,045 1,143	0,010 0,254	14
14	7/8	0,8750 22,2250	1,6250 41,2750	0,760 19,304	0,875 22,225	1,375 34,925	0,020 0,508	0,005 0,127	0,045 1,143	0,010 0,254	7
16	1	1,0000 25,4000	2,1250 53,9750	1,010 25,654	1,375 34,925	1,937 49,200	0,020 0,508	0,005 0,127	0,045 1,143	0,010 0,254	15
20	1 1/4	1,2500 31,7500	2,3750 60,3250	1,135 28,829	1,500 38,100	2,156 54,762	0,030 0,763	0,005 0,127	0,045 1,143	0,010 0,254	12
24	1 1/2	1,5000 38,1000	2,6875 68,2625	1,228 31,191	1,687 42,850	2,437 61,900	0,040 1,016	0,005 0,127	0,045 1,143	0,010 0,254	12
28	1 3/4	1,7500 44,4500	3,0000 76,2000	1,322 33,579	1,812 46,025	2,750 69,850	0,040 1,016	0,005 0,127	0,045 1,143	0,010 0,254	12
32	2	2,0000 50,8000	3,2500 82,5500	1,385 35,179	1,937 49,200	3,000 76,200	0,040 1,016	0,005 0,127	0,045 1,143	0,010 0,254	12



Designation system

Examples: SW03GXC Y2
SW10Z

SW 03 G X C Y2

Basic designation

Bore code (multiples of 1/16 inch)

Chamfer and groove

Z Chamfered outer ring
G Grooved outer ring

Starting torque

No code Standard
X Reduced

Surface treatment of outer ring

No code Not plated
C¹⁾ Cadmium plated external dimensions
J¹⁾ Zinc-nickel plated external dimensions

Oversize

No code Standard outer diameter size
Y1¹⁾ 0.005 in/0,127 mm oversized outer diameter
Y2¹⁾ 0.010 in/0,254 mm oversized outer diameter
Y3¹⁾ 0.015 in/0,381 mm oversized outer diameter
Y4¹⁾ 0.020 in/0,508 mm oversized outer diameter

¹⁾ SKF option

Loads and torque

Nominal bore code	Size	Mass ≈	Static limit loads		Radial limit load C ₂₅	Starting torque	
			Radial C _s	Axial C _a ²⁾		Standard	Reduced starting torque ³⁾ Max
		lb/g	lbf/kN		lbf-in/Nm		
12	3/4	0.23	52 300	7 730	22 101	1.0/5.0	1.0
		104,3	232,64	34,38	98,31	0,11/0,56	0,11
14	7/8	0.35	67 300	10 800	28 198	2.0/8.0	2.0
		158,8	299,36	48,04	125,43	0,23/0,90	0,23
16	1	0.97	137 000	19 300	53 698	2.0/8.0	2.0
		440,0	609,40	85,85	238,86	0,23/0,90	0,23
20	1 1/4	1.10	127 781	26 058	66 447	2.0/16.0	2.2
		500,0	568,40	115,91	295,57	0,23/1,81	0,25
24	1 1/2	1.54	158 715	30 963	82 532	2.0/16.0	2.2
		700,0	706,00	137,73	367,12	0,23/1,81	0,25
28	1 3/4	1.98	193 210	36 363	100 175	2.0/16.0	2.2
		900,0	859,44	161,75	445,60	0,23/1,81	0,25
32	2	2.31	223 946	40 466	116 451	2.0/16.0	2.2
		1 050,0	996,16	180,00	518,00	0,23/1,81	0,25

²⁾ These values can be limited by the unstaking load (contact SKF for more information)

³⁾ The minimum starting torque is limited by zero radial and axial internal clearance

2.29 Self-lubricating wide (inch dimensions)

WAS.. (XRL..., 11HW.. or 11BW..) bore code 3 to 9

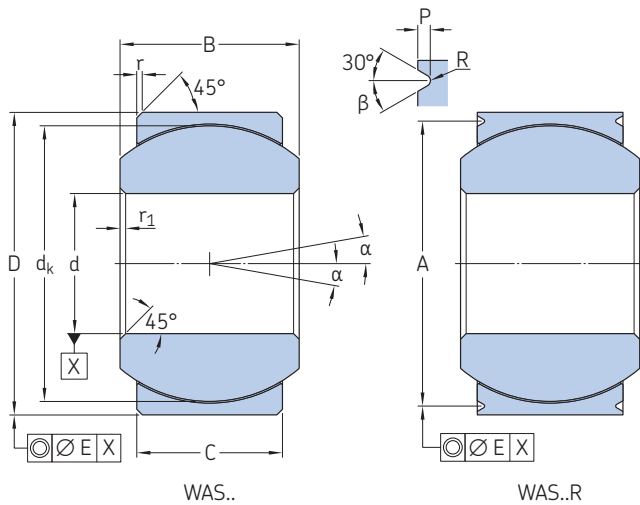

Technical specification	AS 81820
Product standards	AS 14102 (chamfered outer ring) AS 14103 (grooved outer ring)
Materials	
Liner	X1
Inner ring	Passivated corrosion-resistant steel 440C or PH13.8
Outer ring	Corrosion-resistant steel 17-4PH

Nominal bore code	β	E
-	$^{\circ}$	in/mm
≤ 5	20	0.005/0,127
≥ 6	30	0.005/0,127

Dimensions

Nominal bore code	Size	Dimensions											
		d	D	C	B	dk	r ₁	r	A	P	R	$\alpha^{(4)}$	
		0/-0,0005 0/-0,0127	0/-0,0005 0/-0,0127	$\pm 0,005$ $\pm 0,127$	0/-0,002 0/-0,051	\approx	$\pm 0,005$ $\pm 0,127$	+0,010/0 +0,254/0	0/-0,008 0/-0,203	0/-0,010 0/-0,254			
-		in/mm											$^{\circ}$
3	3/16	0.1900 4,826	0.6250 15,875	0.327 8,306	0.437 11,100	0.530 13,464	0.010 0,254	0.010 0,254	0.563 14,300	0.025 0,635	0.005/0.010 0,127/0,254	15	
4	1/4	0.2500 6,350	0.6250 15,875	0.327 8,306	0.437 11,100	0.530 13,464	0.010 0,254	0.010 0,254	0.563 14,300	0.025 0,635	0.005/0.010 0,127/0,254	15	
5	5/16	0.3125 7,938	0.6875 17,462	0.317 8,052	0.437 11,100	0.566 14,381	0.010 0,254	0.010 0,254	0.625 15,875	0.025 0,635	0.005/0.010 0,127/0,254	14	
6	3/8	0.3750 9,525	0.8125 20,638	0.406 10,312	0.500 12,700	0.683 17,361	0.010 0,254	0.020 0,508	0.712 18,085	0.035 0,889	0.010/0.017 0,254/0,432	8	
7	7/16	0.4375 11,113	0.9375 23,812	0.442 11,227	0.562 14,275	0.777 19,744	0.010 0,254	0.020 0,508	0.837 21,260	0.035 0,889	0.010/0.017 0,254/0,432	10	
7A	7/16	0.4375 11,113	0.9062 23,017	0.442 11,227	0.562 14,275	0.777 19,744	0.010 0,254	0.020 0,508	0.806 20,472	0.035 0,889	0.010/0.017 0,254/0,432	10	
8	1/2	0.5000 12,700	1.0000 25,400	0.505 12,827	0.625 15,875	0.871 22,130	0.010 0,254	0.020 0,508	0.900 22,860	0.035 0,889	0.010/0.017 0,254/0,432	9	
9	9/16	0.5625 14,288	1.1250 28,575	0.536 13,614	0.687 17,450	0.996 25,296	0.010 0,254	0.020 0,508	1.025 26,035	0.035 0,889	0.010/0.017 0,254/0,432	10	

Loads and torque

Nominal bore code	Size	Mass \approx	Static limit loads		Radial dynamic load C ₂₅	Starting torque ⁽⁴⁾		
			Radial C _s	Axial C _a ⁽²⁾		Standard	Standard, SKF precision	Reduced ⁽³⁾ max
-		lb/g	lbf/kN			lbf-in/Nm		
3	3/16	0.03 14	2 500 11,12	1 770 7,88	4 900 21,80	0.25/5 0,03/0,56	0.5/5 0,06/0,56	0.5 0,06
4	1/4	0.03 14	5 500 24,47	1 770 7,88	4 900 21,80	0.25/5 0,03/0,56	1/5 0,11/0,56	0.5 0,06
5	5/16	0.035 16	9 400 41,83	1 640 7,30	6 050 26,88	0.25/8 0,03/0,90	1/5 0,11/0,56	1 0,11
6	3/8	0.06 27	13 700 60,96	2 630 11,70	8 310 36,98	0.25/8 0,03/0,90	1/5 0,11/0,56	1 0,11
7	7/16	0.08 38	20 700 92,11	3 650 16,24	11 750 52,29	0.25/8 0,03/0,90	1/5 0,11/0,56	1 0,11
7A	7/16	0.08 38	19 700 87,63	3 650 16,24	11 750 52,29	0.25/8 0,03/0,90	1/5 0,11/0,56	1 0,11
8	1/2	0.10 45	21 400 95,23	4 970 22,12	14 950 66,53	0.25/8 0,03/0,90	1/5 0,11/0,56	1 0,11
9	9/16	0.135 61	26 600 118,37	5 370 23,90	18 100 80,54	0.25/8 0,03/0,90	1/5 0,11/0,56	1 0,11

¹) Parts are delivered and marked with SKF standard XRL..., 11HW.. (inner ring spherical surface coated) or 11BW.. references.

²) These values can be limited by the unstaking load (contact SKF for more information)

⁴) Values are given for non protected bearings. For sealed and shielded bearings, refer to page 149



Cross-reference designation system to XRL..., 11HW.. or 11BW..

Examples:	Z	E	WAS	12	R	X	TT	F	R
ZWAS12RXTTFY2									
WAS 3PPD									
Surface treatment of outer ring									
No code	Not plated								
Z	Cadmium plated external dimensions								
SZ	Zinc-nickel plated external dimensions								
Inner ring material									
No code	440C								
E	PH13.8								
Basic designation									
Bore code (multiples of 1/16 inch)									
Chamfer and groove									
No code³⁾	Chamfered outer ring								
R	Grooved outer ring								
Starting torque									
No code	Standard								
XS¹⁾	Standard, SKF precision								
X	Reduced								
Shield and seal									
No code	No shield and seal								
TT²⁾	Sealed								
PP²⁾	Shielded								
Material and surface treatment of inner ring code									
No code	Passivated inner ring								
F¹⁾	Chromium plated sphere								
D¹⁾	XCR plating on sphere (chromium 6 free replacement to chromium plating)								
K^{1) 4)}	XLHP coated sphere								
N^{1) 4)}	XLNT coated sphere								
H^{1) 4)}	XL coated sphere								
Oversize									
No code	Standard outer diameter size								
Y2	0.010 in/0,254 mm oversized outer diameter								
Y4	0.020 in/0,508 mm oversized outer diameter								

¹⁾ SKF option

²⁾ SKF option, only available for $d \geq 5$

³⁾ SKF option for code 7A

⁴⁾ For sealed (code TT) or shielded (code PP) bearings with XLHP, XLNT or XL coated sphere, contact SKF to check for availability and technical suitability

³⁾ If starting torque is ≤ 0.1 lbf-in (0,01 Nm), maximum internal clearance must be:

Nominal bore code	Maximum radial clearance	Maximum axial clearance
-	in/mm	
≤ 12	0.0007/0,0178	0.0021/0,0533
≥ 14	0.0010/0,0254	0.0040/0,1016

2.29 Self-lubricating wide (inch dimensions)

WAS.. (XRL..., 11HW.. or 11BW..) ²⁾ bore code **10** to **32**

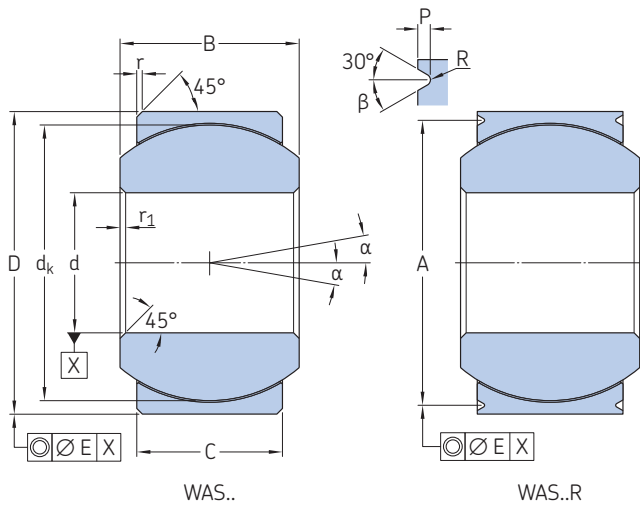

Technical specification	AS 81820
Product standards	AS 14102 (chamfered outer ring) AS 14103 (grooved outer ring)
Materials	
Liner	X1
Inner ring	Passivated corrosion-resistant steel 440C or PH13.8
Outer ring	Corrosion-resistant steel 17-4PH

Nominal bore code	β	E
-	$^{\circ}$	in/mm
≤ 5	20	0.005/0,127
≥ 6	30	0.005/0,127

Dimensions

Nominal bore code	Size	Dimensions											
		d	D	C	B	d_k	r_1	r	A	P	R	α^4	
-		in/mm											$^{\circ}$
10	5/8	0.6250 15,875	1.1875 30,163	0.567 14,400	0.750 19,050	1.059 26,887	0.010 0,254	0.020 0,508	1.087 27,610	0.035 0,889	0.010/0.017 0,254/0,432	12	
12	3/4	0.7500 19,050	1.3750 34,925	0.630 16,002	0.875 22,225	1.216 30,897	0.010 0,254	0.030 0,762	1.251 31,775	0.055 1,397	0.010/0.017 0,254/0,432	13	
14	7/8	0.8750 22,225	1.6250 41,275	0.755 19,177	0.875 22,225	1.325 33,655	0.010 0,254	0.030 0,762	1.501 38,125	0.055 1,397	0.010/0.017 0,254/0,432	6	
16	1	1.0000 25,400	2.1250 53,975	1.005 25,527	1.375 34,925	1.871 47,526	0.010 0,254	0.030 0,762	2.001 50,825	0.055 1,397	0.010/0.017 0,254/0,432	12	
20¹⁾	1 1/4	1.2500 31,750	2.3750 60,325	1.130 28,702	1.500 38,100	2.095 53,203	0.010 0,254	0.030 0,762	2.253 57,230	0.060 1,524	0.010/0.020 0,254/0,508	12	
24¹⁾	1 1/2	1.5000 38,100	2.6875 68,260	1.223 31,064	1.687 42,850	2.393 60,779	0.010 0,254	0.030 0,762	2.565 65,160	0.060 1,524	0.010/0.020 0,254/0,508	12	
28¹⁾	1 3/4	1.7500 44,450	3.0000 76,200	1.317 33,452	1.812 46,020	2.673 67,892	0.010 0,254	0.030 0,762	2.878 73,100	0.060 1,524	0.010/0.020 0,254/0,508	12	
32¹⁾	2	2.0000 50,800	3.2500 82,550	1.380 35,050	1.937 49,190	2.938 74,624	0.010 0,254	0.030 0,762	3.128 79,451	0.060 1,524	0.010/0.020 0,254/0,508	12	

Loads and torque

Nominal bore code	Size	Mass =	Static limit loads		Radial dynamic load C ₂₅	Starting torque ⁴⁾		
			Radial C _s	Axial C _a ³⁾		Standard	Standard, SKF precision	Reduced ⁴⁾ max
-		lb/g	lbf/kN			lbf-in/Nm		
10	5/8	0.16 73	29 000 129,00	6 130 27,28	20 250 90,11	0.25/8 0,03/0,90	1/5 0,11/0,56	1 0,11
12	3/4	0.24 109	37 000 164,65	7 730 34,40	26 200 116,59	0.25/8 0,03/0,90	1/5 0,11/0,56	1 0,11
14	7/8	0.35 159	65 200 290,14	10 800 48,06	33 600 149,52	0.25/12 0,03/1,36	2/8 0,23/0,9	2 0,23
16	1	0.97 440	104 000 462,80	19 300 85,88	56 250 250,31	0.25/12 0,03/1,36	2/8 0,23/0,9	2 0,23
20¹⁾	1 1/4	1.10 500	127 890 568,40	26 080 115,91	66 450 295,57	2/20 0,23/2,26	2.4/15.5 0,28/1,75	2.4 0,28
24¹⁾	1 1/2	1.54 700	158 850 706,00	30 989 137,73	82 536 367,12	2/20 0,23/2,26	2.4/15.5 0,28/1,75	2.4 0,28
28¹⁾	1 3/4	1.99 900	193 374 859,44	36 934 161,75	72 410 445,60	10/35 1,3/3,9	4.5/19 0,5/2,15	4.5 0,5
32¹⁾	2	2.31 1 050	224 136 996,16	40 449 180,00	116 457 518,00	10/35 1,3/3,9	4.5/19 0,5/2,15	4.5 0,5

¹⁾ SKF option ²⁾ Parts are delivered and marked with SKF standard XRL..., 11HW.. (inner ring spherical surface coated) or 11BW.. references.

³⁾ These values can be limited by the unstaking load (contact SKF for more information)

⁴⁾ Values are given for non protected bearings. For sealed and shielded bearings, refer to page 149



Cross-reference designation system to XRL..., 11HW.. or 11BW..

Examples:	Z	E	WAS	12	R	X	TT	F	R
ZWAS12RXTTFY2									
WAS 3PPD									
Surface treatment of outer ring	_____								
No code	Not plated								
Z	Cadmium plated external dimensions								
SZ	Zinc-nickel plated external dimensions								
Inner ring material	_____								
No code	440C								
E	PH13.8								
Basic designation	_____								
Bore code (multiples of 1/16 inch)	_____								
Chamfer and groove	_____								
No code³⁾	Chamfered outer ring								
R	Grooved outer ring								
Starting torque	_____								
No code	Standard								
XS¹⁾	Standard, SKF precision								
X	Reduced								
Shield and seal	_____								
No code	No shield and seal								
TT²⁾	Sealed								
PP²⁾	Shielded								
Material and surface treatment of inner ring code	_____								
No code	Passivated inner ring								
F¹⁾	Chromium plated sphere								
D¹⁾	XCR plating on sphere (chromium 6 free replacement to chromium plating)								
K^{1) 4)}	XLHP coated sphere								
N^{1) 4)}	XLNT coated sphere								
H^{1) 4)}	XL coated sphere								
Oversize	_____								
No code	Standard outer diameter size								
Y2	0.010 in/0,254 mm oversized outer diameter								
Y4	0.020 in/0,508 mm oversized outer diameter								

1) SKF option

2) SKF option, only available for $d \geq 5$

3) SKF option for code 7A

4) For sealed (code TT) or shielded (code PP) bearings with XLHP, XLNT or XL coated sphere, contact SKF to check for availability and technical suitability

4) If starting torque is ≤ 0.1 lbf-in (0,01 Nm), maximum internal clearance must be:

Nominal bore code	Maximum radial clearance	Maximum axial clearance
-	in/mm	
≤ 12	0.0007/0,0178	0.0021/0,0533
≥ 14	0.0010/0,0254	0.0040/0,1016

2.30 Self-lubricating wide (inch dimensions)

WAS..A (XRL..A., 11LHW.. or 11LBW..) ²⁾ bore code 3 to 9

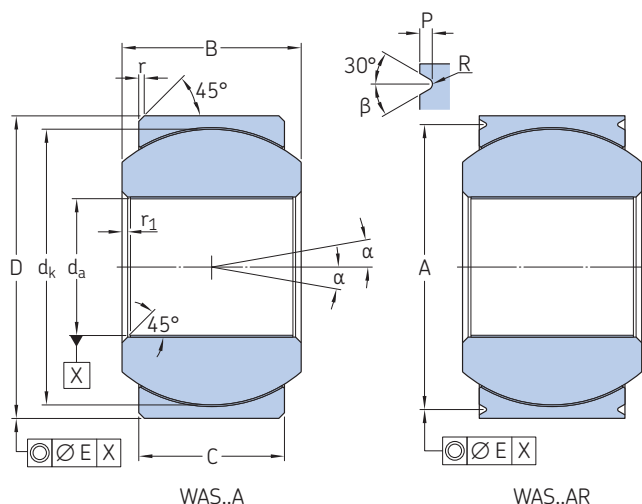

Technical specification	AS 81820
Product standards	AS 81820/2 (lined bore chamfered outer ring) AS 81820/3 (lined bore grooved outer ring)
Materials	
Liner	X1
Inner ring	Passivated corrosion-resistant steel 440C or PH13.8
Outer ring	Corrosion-resistant steel 17-4PH

β	E
°	in/mm
30	0.006/0,152

Dimensions

Nominal bore code	Size	Dimensions											
		d_a	D	C	B	d_k	r_1 max	r	A	P	R	$\alpha^{4)}$	
		0/-0,0010 0/-0,0254	0/-0,0005 0/-0,0127	$\pm 0,005$ $\pm 0,127$	0/-0,002 0/-0,051	\approx		+0,010/0 +0,254/0	0/-0,008 0/-0,203	0/-0,010 0/-0,254			
		in/mm											
3 ¹⁾	3/16	0.1910 4,851	0.6250 15,875	0.327 8,306	0.437 11,100	0.530 13,464	0.005 0,127	0.015 0,381	0.563 14,300	0.025 0,635	0.005/0.012 0,127/0,305	15	
4 ¹⁾	1/4	0.2510 6,375	0.6250 15,875	0.327 8,306	0.437 11,100	0.530 13,464	0.005 0,127	0.015 0,381	0.563 14,300	0.025 0,635	0.005/0.012 0,127/0,305	15	
5	5/16	0.3135 7,963	0.6875 17,462	0.317 8,052	0.437 11,100	0.566 14,381	0.005 0,127	0.015 0,381	0.625 15,875	0.025 0,635	0.005/0.012 0,127/0,305	14	
6	3/8	0.3760 9,550	0.8125 20,638	0.406 10,312	0.500 12,700	0.683 17,361	0.005 0,127	0.020 0,508	0.712 18,085	0.035 0,889	0.010/0.017 0,254/0,432	8	
7	7/16	0.4385 11,138	0.9375 23,812	0.442 11,227	0.562 14,275	0.777 19,744	0.005 0,127	0.020 0,508	0.837 21,260	0.035 0,889	0.010/0.017 0,254/0,432	10	
7A	7/16	0.4385 11,138	0.9062 23,017	0.442 11,227	0.562 14,275	0.777 19,744	0.005 0,127	0.020 0,508	0.806 20,472	0.035 0,889	0.010/0.017 0,254/0,432	10	
8	1/2	0.5010 12,725	1.0000 25,400	0.505 12,827	0.625 15,875	0.871 22,130	0.005 0,127	0.020 0,508	0.900 22,860	0.035 0,889	0.010/0.017 0,254/0,432	9	
9	9/16	0.5635 14,313	1.1250 28,575	0.536 13,614	0.687 17,450	0.996 25,296	0.005 0,127	0.020 0,508	1.025 26,035	0.035 0,889	0.010/0.017 0,254/0,432	10	

Loads and torque

Nominal bore code	Size	Mass =	Static limit loads		Radial dynamic load C ₂₅	Starting torque ⁴⁾		
			Radial C _s	Axial C _a ³⁾		Standard	Standard, SKF precision	Reduced ⁴⁾ max
		lb/g	lbf/kN			lbf-in/Nm		
3 ¹⁾	3/16	0.03 14	2 500 11,12	1 770 7,88	4 900 21,80	0.25/5 0,03/0,56	0.5/5 0,06/0,56	0.5 0,06
4 ¹⁾	1/4	0.03 14	5 500 24,47	1 770 7,88	4 900 21,80	0.25/5 0,03/0,56	1/5 0,11/0,56	0.5 0,06
5	5/16	0.035 16	9 400 41,83	1 640 7,30	6 050 26,88	1/15 0,11/1,69	1/5 0,11/0,56	1 0,11
6	3/8	0.06 27	13 700 60,96	2 630 11,70	8 310 36,98	1/15 0,11/1,69	1/5 0,11/0,56	1 0,11
7	7/16	0.08 38	20 700 92,11	3 650 16,24	11 750 52,29	1/15 0,11/1,69	1/5 0,11/0,56	1 0,11
7A	7/16	0.08 38	19 700 87,63	3 650 16,24	11 750 52,29	1/15 0,11/1,69	1/5 0,11/0,56	1 0,11
8	1/2	0.10 45	21 400 95,23	4 970 22,12	14 950 66,53	1/15 0,11/1,69	1/5 0,11/0,56	1 0,11
9	9/16	0.135 61	26 600 118,37	5 370 23,90	18 100 80,54	1/15 0,11/1,69	1/5 0,11/0,56	1 0,11

1) SKF option 2) Parts are delivered and marked with SKF standard XRL..A., 11LHW (inner ring spherical surface coated) or 11LBW.. references.

3) These values can be limited by the unstaking load (contact SKF for more information)

4) Values are given for non protected bearings. For sealed and shielded bearings, refer to page 149



Cross-reference designation system to XRE..A, 11LHN.. or 11LBN..

Examples:	Z	E	WAS	12	A	R	X	TT	F	Y2
ZWAS12ARXTTFY2										
WAS 3APPD										
Surface treatment of outer ring	_____									
No code	Not plated									
Z	Cadmium plated external dimensions									
SZ	Zinc-nickel plated external dimensions									
Inner ring material	_____									
No code	440C									
E	PH13.8									
Basic designation	_____									
Bore code (multiples of 1/16 inch)	_____									
Chamfer and groove	_____									
No code³⁾	Chamfered outer ring									
R	Grooved outer ring									
Starting torque	_____									
No code	Standard									
XS¹⁾	Standard, SKF precision									
X	Reduced									
Shield and seal	_____									
No code	No shield and seal									
TT²⁾	Sealed									
PP²⁾	Shielded									
Material and surface treatment of inner ring code	_____									
No code	Passivated inner ring									
F¹⁾	Chromium plated sphere									
D¹⁾	XCR plating on sphere (chromium 6 free replacement to chromium plating)									
K^{1) 4)}	XLHP coated sphere									
N^{1) 4)}	XLNT coated sphere									
H^{1) 4)}	XL coated sphere									
Oversize	_____									
No code	Standard outer diameter size									
Y2	0.010 in/0,254 mm oversized outer diameter									
Y4	0.020 in/0,508 mm oversized outer diameter									

1) SKF option

2) SKF option, only available for $d \geq 5$

3) SKF option for code 7A

4) For sealed (code TT) or shielded (code PP) bearings with XLHP, XLNT or XL coated sphere, contact SKF to check for availability and technical suitability

4) If starting torque is ≤ 0.1 lbf-in (0,01 Nm), maximum internal clearance must be:

Nominal bore code	Maximum radial clearance	Maximum axial clearance
-	in/mm	
≤ 12	0.0007/0,0178	0.0021/0,0533
≥ 14	0.0010/0,0254	0.0030/0,0762

2.30 Self-lubricating wide (inch dimensions)

WAS..A (XRL..A., 11LHW.. or 11LBW..) bore code **10** to **32**

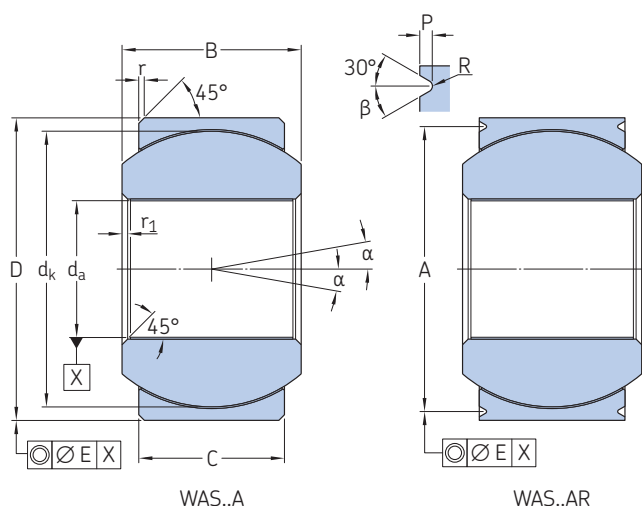

Technical specification	AS 81820
Product standards	AS 81820/2 (lined bore chamfered outer ring) AS 81820/3 (lined bore grooved outer ring)
Materials	
Liner	X1
Inner ring	Passivated corrosion-resistant steel 440C or PH13.8
Outer ring	Corrosion-resistant steel 17-4PH

β	E
°	in/mm
30	0.006/0,152

Dimensions

Nominal bore code	Size	Dimensions										$\alpha^{(4)}$	
		d_a	D	C	B	d_k	$r_{1 \max}$	r	A	P	R		
		0/-0,0010 0/-0,0254	0/-0,0005 0/-0,0127	$\pm 0,005$ $\pm 0,127$	0/-0,002 0/-0,051	\approx		+0,010/0 +0,254/0	0/-0,008 0/-0,203	0/-0,010 0/-0,254			
		in/mm										°	
10	5/8	0.6260 15,900	1.1875 30,163	0.567 14,400	0.750 19,050	1.059 26,887	0.010 0,254	0.020 0,508	1.087 27,610	0.035 0,889	0.010/0.017 0,254/0,432	12	
12	3/4	0.7510 19,075	1.3750 34,925	0.630 16,002	0.875 22,225	1.216 30,897	0.005 0,127	0.030 0,762	1.251 31,775	0.055 1,397	0.010/0.017 0,254/0,432	13	
14	7/8	0.8760 22,250	1.6250 41,275	0.755 19,177	0.875 22,225	1.325 33,655	0.005 0,127	0.030 0,762	1.501 38,125	0.055 1,397	0.010/0.017 0,254/0,432	6	
16	1	1.0010 25,425	2.1250 53,975	1.005 25,527	1.375 34,925	1.871 47,526	0.005 0,127	0.030 0,762	2.001 50,825	0.055 1,397	0.010/0.017 0,254/0,432	12	
20¹⁾	1 1/4	1.2510 31,775	2.3750 60,325	1.130 28,702	1.500 38,100	2.095 53,203	0.005 0,127	0.030 0,762	2.253 57,230	0.060 1,524	0.010/0.020 0,254/0,508	12	
24¹⁾	1 1/2	1.5010 38,125	2.6875 68,260	1.223 31,064	1.687 42,850	2.393 60,779	0.005 0,127	0.030 0,762	2.565 65,160	0.060 1,524	0.010/0.020 0,254/0,508	12	
28¹⁾	1 3/4	1.7510 44,475	3.0000 76,200	1.317 33,452	1.812 46,020	2.673 67,892	0.005 0,127	0.030 0,762	2.878 73,100	0.060 1,524	0.010/0.020 0,254/0,508	12	
32¹⁾	2	2.0010 50,825	3.2500 82,550	1.380 35,050	1.937 49,190	2.938 74,624	0.005 0,127	0.030 0,762	3.128 79,451	0.060 1,524	0.010/0.020 0,254/0,508	12	

Loads and torque

Nominal bore code	Size	Mass ≈ lb/g	Static limit loads		Radial dynamic load C ₂₅	Starting torque ⁽⁴⁾		
			Radial C _s	Axial C _a ⁽³⁾		Standard	Standard, SKF precision	Reduced ⁽⁴⁾ max
			lbf/kN			lbf-in/Nm		
10	5/8	0.16 73	29 000 129,00	6 130 27,28	20 250 90,11	1/15 0,11/1,69	1/5 0,11/0,56	1 0,11
12	3/4	0.24 109	37 000 164,65	7 730 34,40	26 200 116,59	1/15 0,11/1,69	1/5 0,11/0,56	1 0,11
14	7/8	0.35 159	65 200 290,14	10 800 48,06	33 600 149,52	1/25 0,11/2,82	2/8 0,23/0,9	2 0,23
16	1	0.97 440	104 000 462,80	19 300 85,88	56 250 250,31	1/25 0,11/2,82	2/8 0,23/0,9	2 0,23
20¹⁾	1 1/4	1.10 500	127 890 568,40	26 080 115,91	66 450 295,57	2/20 0,23/2,26	2.4/15.5 0,28/1,75	2.4 0,28
24¹⁾	1 1/2	1.54 700	158 850 706,00	30 989 137,73	82 536 367,12	2/20 0,23/2,26	2.4/15.5 0,28/1,75	2.4 0,28
28¹⁾	1 3/4	1.99 900	193 374 859,44	36 934 161,75	72 410 445,60	10/35 1,3/3,9	4.5/19 0,5/2,15	4.5 0,5
32¹⁾	2	2.31 1 050	224 136 996,16	40 449 180,00	116 457 518,00	10/35 1,3/3,9	4.5/19 0,5/2,15	4.5 0,5

¹⁾ SKF option ²⁾ Parts are delivered and marked with SKF standard XRL..A., 11LHW (inner ring spherical surface coated) or 11LBW.. references.

³⁾ These values can be limited by the unstaking load (contact SKF for more information)

⁴⁾ Values are given for non protected bearings. For sealed and shielded bearings, refer to page 149



Cross-reference designation system to XRE..A, 11LHN.. or 11LBN..

Examples: ZWAS12ARXTTFY2 Z E WAS 12 A R X TT F Y2
 WAS 3APPD

Surface treatment of outer ring

No code Not plated
Z Cadmium plated external dimensions
SZ Zinc-nickel plated external dimensions

Inner ring material

No code 440C
E PH13.8

Basic designation

Bore code (multiples of 1/16 inch)

Chamfer and groove

No code³⁾ Chamfered outer ring
R Grooved outer ring

Starting torque

No code Standard
XS¹⁾ Standard, SKF precision
X Reduced

Shield and seal

No code No shield and seal
TT²⁾ Sealed
PP²⁾ Shielded

Material and surface treatment of inner ring code

No code Passivated inner ring
F¹⁾ Chromium plated sphere
D¹⁾ XCR plating on sphere (chromium 6 free replacement to chromium plating)
K^{1) 4)} XLHP coated sphere
N^{1) 4)} XLNT coated sphere
H^{1) 4)} XL coated sphere

Oversize

No code Standard outer diameter size
Y2 0.010 in/0,254 mm oversized outer diameter
Y4 0.020 in/0,508 mm oversized outer diameter

¹⁾ SKF option

²⁾ SKF option, only available for $d \geq 5$

³⁾ SKF option for code 7A

⁴⁾ For sealed (code TT) or shielded (code PP) bearings with XLHP, XLNT or XL coated sphere, contact SKF to check for availability and technical suitability

⁴⁾ If starting torque is ≤ 0.1 lbf-in (0,01 Nm), maximum internal clearance must be:

Nominal bore code	Maximum radial clearance	Maximum axial clearance
-	in/mm	
≤ 12	0.0007/0,0178	0.0021/0,0533
≥ 14	0.0010/0,0254	0.0030/0,0762

2.31 Self-lubricating high misalignment (inch dimensions)

SH..

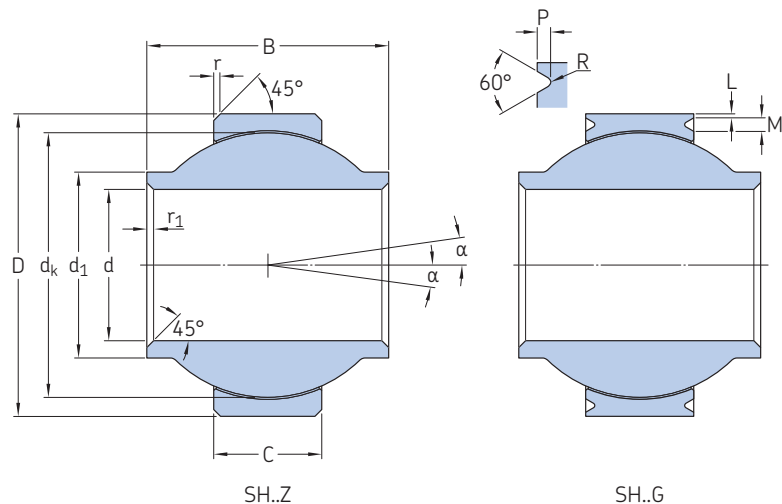

Technical specification	–
Product standards	–
Materials	X1
Liner	Corrosion-resistant steel 440C
Inner ring	Corrosion-resistant steel 17-4PH
Outer ring	

Nominal bore code	L	M
–	+0.010/0 +0,254/0	+0.010/0 +0,254/0
– in/mm		
≤ 04	0.010/0,254	0.035/0,889
05 to 08	0.020/0,508	0.045/1,143
≥ 10	0.020/0,508	0.070/1,778

Dimensions

Nominal bore code	Size	Dimensions										
		d	D	C	B	dk	d1	r	r1	P	R	α
		0/–0.0005 0/–0,0127	0/–0.0005 0/–0,0127	0/–0.010 0/–0,254	0/–0.002 0/–0,051	≈	≈	0/–0.010 0/–0,254	+0.010/0 +0,254/0	+0.015/0 +0,381/0	0/0.010 0/0,254	°
–		in/mm										
03	3/16	0.1900 4,8260	0.6250 15,8750	0.332 8,433	0.560 14,224	0.531 13,487	0.28 7,112	0.035 0,889	0.005 0,127	0.015 0,381	0.005 0,127	15
04	1/4	0.2500 6,3500	0.7400 18,7960	0.260 6,604	0.593 15,062	0.593 15,062	0.35 8,890	0.035 0,889	0.005 0,127	0.015 0,381	0.005 0,127	24
05	5/16	0.3125 7,9375	0.9060 23,0124	0.350 8,890	0.813 20,650	0.781 19,837	0.48 12,192	0.035 0,889	0.005 0,127	0.025 0,635	0.010 0,254	22
06	3/8	0.3750 9,5250	0.9060 23,0124	0.350 8,890	0.813 20,650	0.781 19,837	0.48 12,192	0.035 0,889	0.005 0,127	0.025 0,635	0.010 0,254	22
07	7/16	0.4375 11,1125	1.0000 25,4000	0.350 8,890	0.875 22,225	0.875 22,225	0.57 14,478	0.035 0,889	0.005 0,127	0.025 0,635	0.010 0,254	22
08	1/2	0.5000 12,7000	1.1250 28,5750	0.406 10,312	0.937 23,800	1.000 25,400	0.68 17,272	0.035 0,889	0.005 0,127	0.025 0,635	0.010 0,254	20
10	5/8	0.6250 15,8750	1.3750 34,9250	0.572 14,529	1.200 30,480	1.250 31,750	0.81 20,574	0.035 0,889	0.005 0,127	0.045 1,143	0.010 0,254	20
12	3/4	0.7500 19,0500	1.5625 39,6875	0.625 15,875	1.280 32,512	1.375 34,925	0.92 23,368	0.035 0,889	0.005 0,127	0.045 1,143	0.010 0,254	19
14	7/8	0.8750 22,2250	1.7500 44,4500	0.630 16,002	1.400 35,560	1.531 38,887	1.08 27,432	0.035 0,889	0.005 0,127	0.045 1,143	0.010 0,254	19
16	1	1.0000 25,4000	2.1250 53,9750	0.840 21,336	1.875 47,625	1.875 47,625	1.22 30,988	0.035 0,889	0.005 0,127	0.045 1,143	0.010 0,254	21
20	1 1/4	1.2500 31,7500	2.5000 63,5000	1.010 25,654	1.875 47,625	2.250 57,150	1.50 38,100	0.035 0,889	0.005 0,127	0.045 1,143	0.010 0,254	21



Designation system

Examples: SH03GCY2
SH10Z

SH 03 G C Y2

Basic designation

Bore code (multiples of 1/16 inch)

Chamfer and groove

Z Chamfered outer ring
G Grooved outer ring

Surface treatment of outer ring

No code Not plated
C Cadmium plated external dimensions
J Zinc-nickel plated external dimensions

Oversize

No code Standard outer diameter size
Y1 0.005 in/0,127 mm oversized outer diameter
Y2 0.010 in/0,254 mm oversized outer diameter
Y3 0.015 in/0,381 mm oversized outer diameter
Y4 0.020 in/0,508 mm oversized outer diameter

Loads and torque

Nominal bore code	Size	Mass ≈	Static limit loads		No load dynamic torque ²⁾ Max
			Radial C _s	Axial C _a ¹⁾	
–		lb/g	lbf/kN		lbf-in/Nm
03	3/16	0,03	9 000	1 550	5
		13,6	40,03	6,89	0,56
04	1/4	0,04	7 000	600	5
		18,1	31,14	2,67	0,56
05	5/16	0,07	14 000	1 600	5
		31,8	62,28	7,12	0,56
06	3/8	0,07	14 000	1 600	5
		31,8	62,28	7,12	0,56
07	7/16	0,10	15 000	1 700	8
		45,4	66,72	7,56	0,90
08	1/2	0,16	20 000	2 500	8
		72,6	88,96	11,12	0,90
10	5/8	0,25	37 000	4 000	8
		113,4	164,58	17,79	0,90
12	3/4	0,32	45 500	4 800	8
		145,1	202,39	21,35	0,90
14	7/8	0,43	50 000	5 000	8
		195,0	222,41	22,24	0,90
16	1	0,81	85 000	11 100	8
		367,4	378,10	49,38	0,90
20	1 1/4	1,11	124 000	13 500	20
		503,5	551,58	60,05	2,26

¹⁾ These values can be limited by the unstaking load (contact SKF for more information)

²⁾ The minimum starting torque is limited by zero radial and axial internal clearance

2.32 Self-lubricating high misalignment (inch dimensions)

11..H

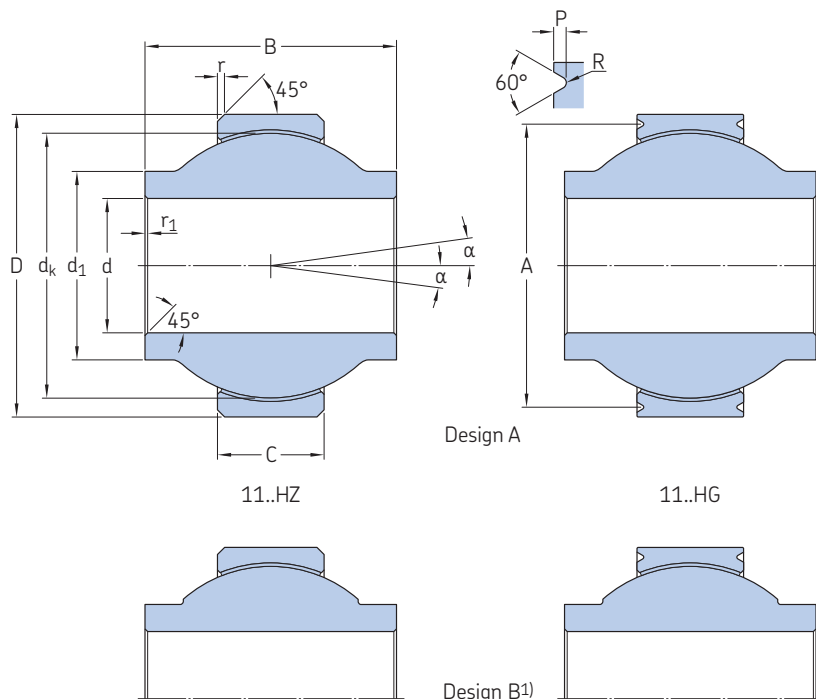

Technical specification	–
Product standards	–
Materials	
Liner	X1
Inner ring	Corrosion-resistant steel 440C or PH13.8
Outer ring	Corrosion-resistant steel 17-4PH

2.32



Dimensions

Nominal bore code	Size	Dimensions								
		d	D	C	B	dk	d1	r	r1	A
		0/-0.0005 0/-0,0127	0/-0.0005 0/-0,0127	0/-0.010 0/-0,254	0/-0.002 0/-0,051	≈	≈	+0.010/0 +0,254/0	+0.010/0 +0,254/0	0/-0.010 0/-0,254
– in/mm										
03	3/16	0.1900 4,8260	0.5625 14,2875	0.215 5,461	0.500 12,700	0.437 11,100	0.312 7,925	0.025 0,635	0.005 0,127	0.502 12,751
031	3/16	0.1900 4,8260	0.6250 15,8750	0.332 8,433	0.560 14,224	0.531 13,487	0.280 7,112	0.025 0,635	0.005 0,127	0.560 14,224
04	1/4	0.2500 6,3500	0.7400 18,7960	0.260 6,604	0.593 15,062	0.593 15,062	0.350 8,890	0.025 0,635	0.005 0,127	0.675 17,145
05	5/16	0.3125 7,9375	0.9060 23,0124	0.350 8,890	0.813 20,650	0.781 19,837	0.480 12,192	0.025 0,635	0.005 0,127	0.811 20,599
051	5/16	0.3125 7,9375	0.6875 17,4625	0.245 6,223	0.625 15,875	0.593 15,062	0.420 10,668	0.025 0,635	0.005 0,127	0.637 16,180
06	3/8	0.3750 9,5250	0.9060 23,0124	0.350 8,890	0.813 20,650	0.781 19,837	0.480 12,192	0.025 0,635	0.005 0,127	0.811 20,599
07	7/16	0.4375 11,1125	1.0000 25,4000	0.350 8,890	0.875 22,225	0.875 22,225	0.570 14,478	0.025 0,635	0.005 0,127	0.905 22,987
08	1/2	0.5000 12,7000	1.1250 28,5750	0.406 10,312	0.937 23,800	1.000 25,400	0.680 17,272	0.025 0,635	0.005 0,127	1.030 26,162
10	5/8	0.6250 15,8750	1.3750 34,9250	0.572 14,529	1.200 30,480	1.250 31,750	0.810 20,574	0.025 0,635	0.005 0,127	1.255 31,877
12	3/4	0.7500 19,0500	1.5625 39,6875	0.625 15,875	1.280 32,512	1.375 34,925	0.920 23,368	0.025 0,635	0.005 0,127	1.442 36,627
14	7/8	0.8750 22,2250	1.7500 44,4500	0.630 16,002	1.400 35,560	1.531 38,887	1.080 27,432	0.025 0,635	0.005 0,127	1.630 41,402
16	1	1.0000 25,4000	2.1250 53,9750	0.840 21,336	1.875 47,625	1.875 47,625	1.220 30,988	0.025 0,635	0.005 0,127	2.005 50,927
20	1 1/4	1.2500 31,7500	2.5000 63,5000	1.010 25,654	1.875 47,625	2.250 57,150	1.500 38,100	0.025 0,635	0.005 0,127	2.380 60,452
24	1 1/2	1.5000 38,1000	3.0000 76,2000	1.180 29,972	2.250 57,150	2.672 67,869	1.802 45,771	0.025 0,635	0.005 0,127	2.880 73,152

1) Slight reduction of misalignment angle α (contact SKF for more information)



Designation system

Examples: 11BHG03EXCY2
11HHZ10J

11 B H G 03 E X C Y2

Basic designation

Coating of inner ring

B	Passivated (Design A)
H	XL coated sphere (Design B)
K	XLHP coated sphere (Design A)
N	XLNT coated sphere (Design B)
D	XCR plating on sphere (chromium 6 free replacement to chromium plating) (Design A)

Chamfer and groove

Z	Chamfered outer ring
G	Grooved outer ring

Bore code (multiples of 1/16 inch)

Inner ring material

No code	440C
E	PH13.8

Starting torque

No code	Standard
X	Reduced

Surface treatment of outer ring

No code	Not plated
C	Cadmium plated external dimensions
J	Zinc-nickel plated external dimensions

Oversize

No code	Standard outer diameter size
Y1	0.005 in / 0.127 mm oversized outer diameter
Y2	0.010 in / 0.254 mm oversized outer diameter
Y3	0.015 in / 0.381 mm oversized outer diameter
Y4	0.020 in / 0.508 mm oversized outer diameter

Dimensions cont., loads and torque

Nominal bore code	Size	Dimensions		$\alpha^{1)}$	Mass \approx	Static limit loads		Starting torque	
		P 0/-0.015 0/-0.381	R 0/-0.010 0/-0.254			Radial C_s	Axial $C_{a^{2)}$	Standard	Reduced ³⁾
		in/mm		°	lb/g	lbf/kN	lbf-in/Nm		
03	3/16	0.030 0,762	0.015 0,381	15	0.02 9,1	4 970 22,11	315 1,40	0.25/5.0 0,03/0,56	0.5 0,06
031	3/16	0.030 0,762	0.015 0,381	15	0.03 13,6	10 500 46,71	1 785 7,94	0.25/5.0 0,03/0,56	0.5 0,06
04	1/4	0.030 0,762	0.015 0,381	24	0.04 18,1	8 120 36,12	700 3,11	0.25/5.0 0,03/0,56	0.5 0,06
05	5/16	0.040 1,016	0.020 0,508	22	0.07 31,8	16 310 72,55	1 855 8,25	0.25/5.0 0,03/0,56	1 0,11
051	5/16	0.030 0,762	0.015 0,381	20	0.03 13,6	7 910 35,19	525 2,34	0.25/5.0 0,03/0,56	1 0,11
06	3/8	0.040 1,016	0.020 0,508	22	0.07 31,8	16 310 72,55	1 855 8,25	0.25/5.0 0,03/0,56	1 0,11
07	7/16	0.040 1,016	0.020 0,508	22	0.10 45,4	17 500 77,84	1 960 8,72	0.50/8.0 0,06/0,9	1 0,11
08	1/2	0.040 1,016	0.020 0,508	20	0.16 72,6	23 310 103,69	2 905 12,92	0.50/8.0 0,06/0,9	1 0,11
10	5/8	0.060 1,524	0.020 0,508	20	0.25 113,4	43 120 191,81	6 600 29,36	1.0/8.0 0,11/0,90	1 0,11
12	3/4	0.060 1,524	0.020 0,508	19	0.32 145,1	53 060 236,02	7 700 34,25	1.0/8.0 0,11/0,90	1 0,11
14	7/8	0.060 1,524	0.020 0,508	19	0.43 195,0	58 310 259,38	7 700 34,25	1.0/8.0 0,11/0,90	2 0,23
16	1	0.060 1,524	0.020 0,508	21	0.81 367,4	99 120 440,91	15 400 68,50	2.0/12.0 0,23/1,36	2 0,23
20	1 1/4	0.060 1,524	0.020 0,508	21	1.11 503,5	144 620 643,30	23 100 102,75	2.0/20.0 0,23/2,26	2 0,23
24	1 1/2	0.060 1,524	0.020 0,508	21	2.22 1 007,0	211 330 940,04	27 930 124,24	2.0/20.0 0,23/2,26	2 0,23

1) Values are valid for design A. For design B, the misalignment angle α is slightly reduced (contact SKF for more information) 2) These values can be limited by the unstaking load (contact SKF for more information) 3) The minimum starting torque is limited by zero radial and axial internal clearance

2.33 Self-lubricating high misalignment (inch dimensions)

XRT.. bore code 4,83 to 12,7

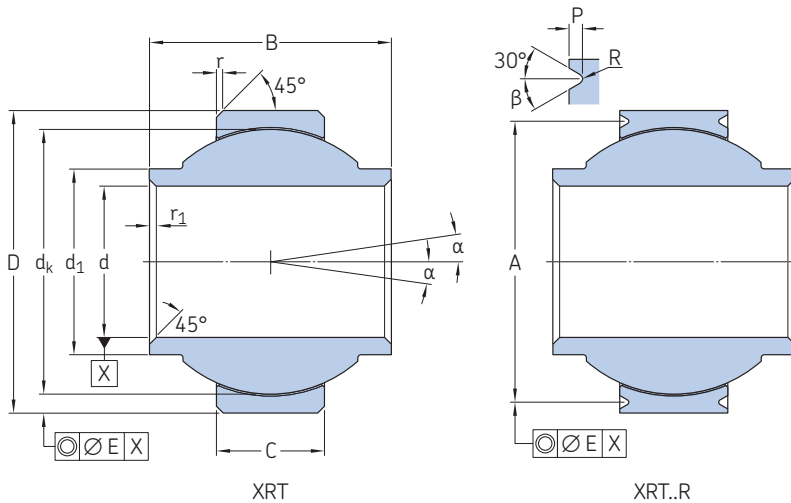

Technical specification	–
Product standards	–
Materials	
Liner	X1
Inner ring	Corrosion-resistant steel 440C or PH13.8
Outer ring	Corrosion-resistant steel 17-4PH

d	β	E
in/mm	°	in/mm
0.1900/0.4375 4,826/11,113	20	0.005 0,127
0.5000/1.2500 12,7/31,75	30	0.005 0,127

Dimensions

Nominal bore code	Dash number multiples of 1/16 inch	Dimensions d Bore without liner 0/-0.0005 0/-0,0127	da = d with lined bore + 0.0010/0 + 0,0250/0	D	C	B	dk	d1	r1	r	A	P
–		in/mm										
4,83	03	0.1900 4,826	0.1900 4,826	0.5625 14,288	0.205 5,207	0.500 12,700	0.437 11,100	0.315 8,001	0.004 0,100	0.020 0,508	0.502 12,751	0.030 0,762
6,35	04	0.2500 6,350	0.2500 6,350	0.7400 18,796	0.250 6,350	0.593 15,062	0.594 15,080	0.386 9,804	0.004 0,100	0.020 0,508	0.669 17,000	0.030 0,762
7,94	05	0.3125 7,938	0.3125 7,938	0.9060 23,012	0.340 8,636	0.813 20,650	0.781 19,838	0.512 13,005	0.004 0,100	0.020 0,508	0.831 21,100	0.030 0,762
9,52	06	0.3750 9,525	0.3750 9,525	0.9060 23,012	0.340 8,636	0.813 20,650	0.781 19,838	0.532 13,513	0.004 0,100	0.020 0,508	0.831 21,100	0.030 0,762
11,11	07	0.4375 11,113	0.4375 11,113	1.0000 25,400	0.340 8,636	0.875 22,225	0.866 22,000	0.620 15,748	0.004 0,100	0.020 0,508	0.925 23,500	0.030 0,762
12,7	08	0.5000 12,700	0.5000 12,700	1.1250 28,575	0.396 10,058	0.937 23,799	0.984 25,000	0.728 18,491	0.004 0,100	0.020 0,508	1.047 26,600	0.030 0,762

Dimensions cont., loads and torque

Nominal bore code	Dash number multiples of 1/16 inch	Dimensions		Mass ≈ lb/g	Static limit loads		Radial dynamic load C25	Starting torque ²⁾	
		R	α ²⁾		Radial Cs	Axial Ca ¹⁾		Standard	Reduced Max
–		in/mm			lbf/kN			lbf-in/Nm	
4,83	03	0.005/0.010 0,127/0,254	15	0.02 9	3 642 16,2	899 4,0	1 461 6,5	0.5/2.5 0,06/0,28	0.5 0,06
6,35	04	0.005/0.010 0,127/0,254	24	0.04 18	6 924 30,8	517 2,3	2 765 12,3	0.5/2.5 0,06/0,28	0.5 0,06
7,94	05	0.005/0.010 0,127/0,254	23	0.07 32	12 544 55,8	1 304 5,8	5 013 22,3	0.7/3.5 0,080/0,40	1 0,11
9,52	06	0.005/0.010 0,127/0,254	22	0.07 32	12 544 55,8	1 304 5,8	5 013 22,3	0.9/4.5 0,10/0,51	1 0,11
11,11	07	0.005/0.010 0,127/0,254	22	0.10 45	13 286 59,1	1 394 6,2	5 305 23,6	0.9/4.5 0,10/0,51	1 0,11
12,7	08	0.005/0.010 0,127/0,254	20	0.16 73	18 906 84,1	2 360 10,5	7 553 33,6	0.9/4.5 0,10/0,51	1 0,11

¹⁾ These values can be limited by the unstaking load (contact SKF for more information)

²⁾ Values are given for non protected bearings. For sealed and shielded bearings, refer to page 149



Designation system

Examples: ZXRT19,05ARXTTCP33RP01
 XRT 4,83PPCP109

Surface treatment of outer ring

No code Not plated
Z Cadmium plated external dimensions
SZ Zinc-nickel plated external dimensions

Basic designation

Bore code

Lined bore

No code Bore without liner
A¹⁾ Lined bore

Chamfer and groove

No code Chamfered outer ring
R Grooved outer ring

Starting torque

No code Standard
X Reduced

Shield and seal

No code No shield and seal
TT²⁾ Sealed
PP²⁾ Shielded

Material and surface treatment of inner ring

	Material	Surface treatment
No code	440C	–
CP6	440C	Chromium plated sphere
CP109	440C	XCR plating on sphere (chromium 6 free replacement to chromium plating)
CP55	440C	Passivated inner ring
CP33	PH13.8	–
CP194	PH13.8	Chromium plated sphere
CP195	PH13.8	XCR plating on sphere (chromium 6 free replacement to chromium plating)
CP196	PH13.8	Passivated inner ring

Oversize

No code Standard outer diameter size
RP01 0.010 in/0,254 mm oversized outer diameter
RP02 0.020 in/0,508 mm oversized outer diameter

¹⁾ Only available for $d \geq 6$

²⁾ Only available for $d \geq 7,94$

2.33 Self-lubricating high misalignment (inch dimensions)

XRT.. bore code **15,87** to **31,75**

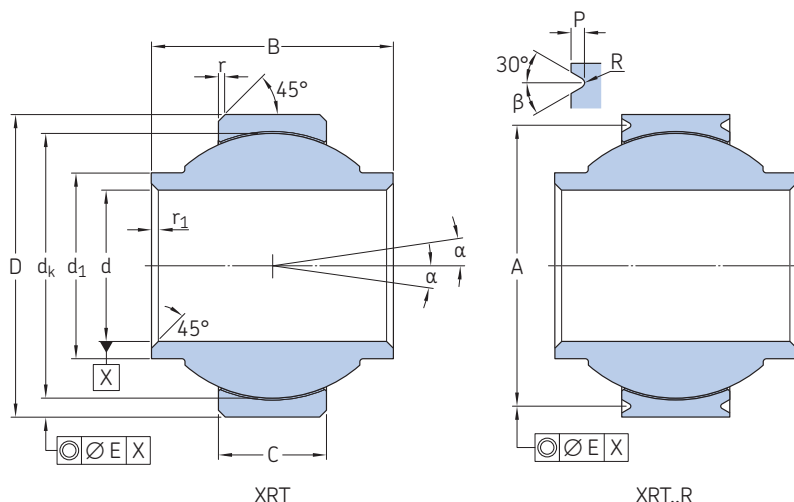

Technical specification	–
Product standards	–
Materials	
Liner	X1
Inner ring	Corrosion-resistant steel 440C or PH13.8
Outer ring	Corrosion-resistant steel 17-4PH

d	β	E
in/mm	°	in/mm
0.1900/0.4375 4,826/11,113	20	0.005 0,127
0.5000/1.2500 12,7/31,75	30	0.005 0,127

Dimensions

Nominal bore code	Dash number multiples of 1/16 inch	Dimensions d	Dimensions d _a	D	C	B	d _k	d ₁	r ₁	r	A	P
		Bore without liner 0/-0,0005 0/-0,0127	= d with lined bore + 0,0010/0 + 0,0250/0	0/-0,0005 0/-0,0127	±0,010 ±0,254	0/-0,005 0/-0,127	≈	≈	+0,012/0 +0,300/0	+0,015/0 +0,381/0	+0,010/0 +0,254/0	0/-0,010 0/-0,254
		in/mm										
15,87	10	0.6250 15,875	0.6250 15,875	1.3750 34,925	0.562 14,275	1.200 30,480	1.240 31,500	0.857 21,768	0.004 0,100	0.020 0,508	1.268 32,200	0.040 1,016
19,05	12	0.7500 19,050	0.7500 19,050	1.5625 39,688	0.615 15,621	1.280 32,512	1.339 34,000	0.963 24,460	0.004 0,100	0.020 0,508	1.437 36,500	0.060 1,524
22,22	14	0.8750 22,225	0.8750 22,225	1.7500 44,450	0.620 15,748	1.400 35,560	1.531 38,887	1.122 28,500	0.004 0,100	0.020 0,508	1.624 41,250	0.060 1,524
25,4	16	1.0000 25,400	1.0000 25,400	2.1250 53,975	0.830 21,082	1.875 47,625	1.875 47,625	1.272 32,309	0.004 0,100	0.020 0,508	2.003 50,876	0.060 1,524
31,75	20	1.2500 31,750	1.2500 31,750	2.5000 63,500	1.000 25,400	1.875 47,625	2.250 57,150	1.523 38,684	0.004 0,100	0.020 0,508	2.370 60,200	0.060 1,524

Dimensions cont., loads and torque

Nominal bore code	Dash number multiples of 1/16 inch	Dimensions R	α ²⁾	Mass ≈	Static limit loads	Radial dynamic load C ₂₅	Starting torque ²⁾					
					Radial C _s	Axial C _a ¹⁾	Standard	Reduced Max				
		in/mm										
		°										
		lb/g										
		lbf/kN										
		lbf-in/Nm										
15,87	10	0.010/0.020 0,254/0,508	20	0.25 114	34 080 151,6	5 553 24,7	1/6.2 0,11/0,70	1 0,11				
19,05	12	0.010/0.020 0,254/0,508	19	0.32 145	51 457 228,9	6 362 28,3	1/6.2 0,11/0,70	1 0,11				
22,22	14	0.010/0.020 0,254/0,508	19	0.43 195	61 708 274,5	6 452 28,7	2.2/9 0,25/1,02	2 0,23				
25,4	16	0.010/0.020 0,254/0,508	21	0.81 367	84 053 373,9	12 206 54,3	2.2/9 0,25/1,02	2 0,23				
31,75	20	0.010/0.020 0,254/0,508	21	1.11 504	119 301 530,7	19 355 86,1	3.5/16 0,395/1,808	2.2 0,25				

¹⁾ These values can be limited by the unstaking load (contact SKF for more information)

²⁾ Values are given for non protected bearings. For sealed and shielded bearings, refer to page 149



Designation system

Examples: ZXRT19,05ARXTTCP33RP01
 XRT 4,83PPCP109

Surface treatment of outer ring

No code Not plated
Z Cadmium plated external dimensions
SZ Zinc-nickel plated external dimensions

Basic designation

Bore code

Lined bore

No code Bore without liner
A¹⁾ Lined bore

Chamfer and groove

No code Chamfered outer ring
R Grooved outer ring

Starting torque

No code Standard
X Reduced

Shield and seal

No code No shield and seal
TT²⁾ Sealed
PP²⁾ Shielded

Material and surface treatment of inner ring

	Material	Surface treatment
No code	440C	–
CP6	440C	Chromium plated sphere
CP109	440C	XCR plating on sphere (chromium 6 free replacement to chromium plating)
CP55	440C	Passivated inner ring
CP33	PH13.8	–
CP194	PH13.8	Chromium plated sphere
CP195	PH13.8	XCR plating on sphere (chromium 6 free replacement to chromium plating)
CP196	PH13.8	Passivated inner ring

Oversize

No code Standard outer diameter size
RP01 0.010 in/0,254 mm oversized outer diameter
RP02 0.020 in/0,508 mm oversized outer diameter

¹⁾ Only available for $d \geq 6$

²⁾ Only available for $d \geq 7,94$

2.34 Self-lubricating pre-staked (inch dimensions)

XRL..FR bore code 6,35 to 12,7

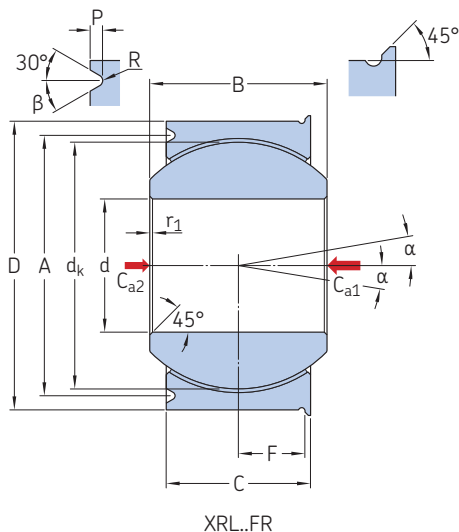

Technical specification	–
Product standards	–
Materials	
Liner	X1
Inner ring	Corrosion-resistant steel 440C or PH13.8
Outer ring	Corrosion-resistant steel 17-4PH

d	β
in/mm	°
0.2500 6,35	20
≥ 0.3125 ≥ 7,938	30

Dimensions

Nominal bore code	Dash number multiples of 1/16 inch	Dimensions									
		d	d _a = d with lined bore	D	C	B	d _k	r ₁	A	P	R
–	–	in/mm									
6,35	4	0.2500 6,350	0.2500 6,350	0.6250 15,875	0.327 8,306	0.437 11,100	0.391 9,919	0.010 0,254	0.563 14,300	0.025 0,635	0.005 0,127
7,94	5	0.3125 7,938	0.3125 7,938	0.6875 17,462	0.317 8,052	0.437 11,100	0.477 12,109	0.010 0,254	0.625 15,875	0.025 0,635	0.005 0,127
9,52	6	0.3750 9,525	0.3750 9,525	0.8125 20,638	0.406 10,312	0.500 12,700	0.598 15,193	0.010 0,254	0.712 18,085	0.035 0,889	0.010 0,254
11,11	7	0.4375 11,113	0.4375 11,113	0.9375 23,812	0.442 11,227	0.562 14,275	0.693 17,594	0.010 0,254	0.837 21,260	0.035 0,889	0.010 0,254
12,7	8	0.5000 12,700	0.5000 12,700	1.0000 25,400	0.505 12,827	0.625 15,875	0.786 19,975	0.010 0,254	0.900 22,860	0.035 0,889	0.010 0,254

Dimensions, loads and torque

Nominal bore code	Dash number multiples of 1/16 inch	Dimensions		Mass	Static limit loads		Radial C _s	Radial dynamic load C ₂₅	Starting torque ¹⁾	
		F	α ¹⁾		Axial C _{a1}	C _{a2}			Standard	Reduced max
–	–	in/mm		lb/g	lbf/kN				lbf-in/Nm	
6,35	4	0.146 3,71	15	0.03 14	1 770 7,87	900 4,00	5 500 24,47	4 900 21,80	1/5 0,11/0,56	0,5 0,06
7,94	5	0.142 3,61	14	0.035 16	1 640 7,30	1 115 4,96	9 400 41,81	6 050 26,91	1/5 0,11/0,56	1 0,11
9,52	6	0.177 4,50	8	0.06 27	2 630 11,70	2 318 10,31	13 700 60,94	8 310 36,96	1/5 0,11/0,56	1 0,11
11,11	7	0.195 4,95	10	0.08 38	3 650 16,24	2 893 12,87	20 700 92,08	11 750 52,27	1/5 0,11/0,56	1 0,11
12,7	8	0.226 5,74	9	0.1 45	4 970 22,11	4 000 17,79	21 400 95,19	14 950 66,50	1/5 0,11/0,56	1 0,11

¹⁾ Values are given for non protected bearings. For sealed and shielded bearings, refer to page 149



Designation system

Examples: ZXRL19,05FRAXTTCP33RP01
 XRL 9,52FRPPCP109

Surface treatment of outer ring

No code Not plated
Z Cadmium plated external dimensions
SZ Zinc-nickel plated external dimensions

Basic designation

Bore code

Lined bore

No code Bore without liner
A¹⁾ Lined bore

Starting torque

No code Standard
X Reduced

Shield and seal

No code No shield and seal
TT¹⁾ Sealed
PP¹⁾ Shielded

Material and surface treatment of inner ring

	Material	Surface treatment
No code	440C	Not plated
CP6	440C	Chromium plated sphere
CP109	440C	XCR plating on sphere (chromium 6 free replacement to chromium plating)
CP55	440C	Passivated inner ring
CP33	PH13.8	Not plated
CP194	PH13.8	Chromium plated sphere
CP195	PH13.8	XCR plating on sphere (chromium 6 free replacement to chromium plating)
CP196	PH13.8	Passivated inner ring

Oversize

No code Standard outer diameter size
RP01 0.010 in/0,254 mm oversized outer diameter
RP02 0.020 in/0,508 mm oversized outer diameter

¹⁾ Only available for $d \geq 7,94$

2.34 Self-lubricating pre-staked (inch dimensions)

XRL..FR bore code **14,29** to **25,4**

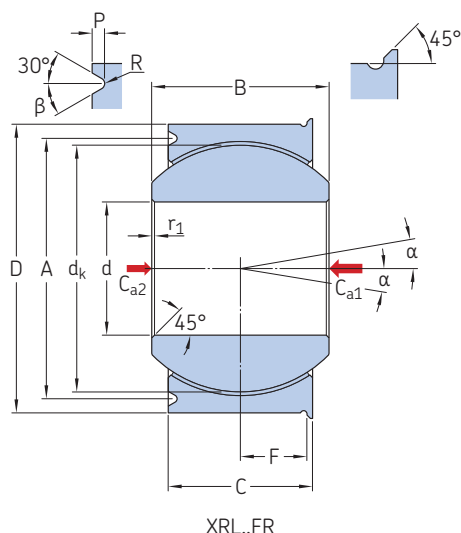

Technical specification	–
Product standards	–
Materials	
Liner	X1
Inner ring	Corrosion-resistant steel 440C or PH13.8
Outer ring	Corrosion-resistant steel 17-4PH

d	β
in/mm	°
0.2500 6,35	20
≥ 0.3125 ≥ 7,938	30

Dimensions

Nominal bore code	Dash number multiples of 1/16 inch	Dimensions		D	C	B	d _k	r ₁	A	P	R
		d	d _a								
		Bore with- out liner 0/-0.0005 0/-0,0127	= d with lined bore +0.0010/0 +0,0250/0	0/-0.0005 0/-0,0127	±0.005 ±0,127	0/-0.002 0/-0,051	≈	± 0.005 ± 0,127	0/-0.010 0/-0,254	0/-0.010 0/-0,254	+0.007/0 +0,178/0
		in/mm									
14,29	9	0.5625 14,288	0.5625 14,288	1.1250 28,575	0.536 13,614	0.687 17,450	0.914 23,227	0.010 0,254	1.025 26,035	0.035 0,889	0.010 0,254
15,87	10	0.6250 15,875	0.6250 15,875	1.1875 30,163	0.567 14,400	0.750 19,050	0.974 24,739	0.010 0,254	1.087 27,610	0.035 0,889	0.010 0,254
19,05	12	0.7500 19,050	0.7500 19,050	1.3750 34,925	0.630 16,002	0.875 22,225	1.130 28,702	0.010 0,254	1.251 31,775	0.055 1,397	0.010 0,254
22,22	14	0.8750 22,225	0.8750 22,225	1.6250 41,275	0.755 19,177	0.875 22,225	1.325 33,655	0.010 0,254	1.501 38,125	0.055 1,397	0.010 0,254
25,4	16	1.0000 25,400	1.0000 25,400	2.1250 53,975	1.005 25,527	1.375 34,925	1.616 41,038	0.010 0,254	2.001 50,825	0.055 1,397	0.010 0,254

Dimensions, loads and torque

Nominal bore code	Dash number multiples of 1/16 inch	Dimensions		Mass	Static limit loads		Radial C _s	Radial dynamic load C ₂₅	Starting torque ¹⁾	
		F	α ¹⁾		Axial C _{a1}	C _{a2}			Standard	Reduced max
		+0.004/0 +0,102/0		≈						
		in/mm								
			°	lb/g	lbf/kN				lbf-in/Nm	
14,29	9	0.242 6,15	10	0.14 61	5 370 23,89	4 678 20,81	26 600 118,32	18 100 80,51	1/5 0,11/0,56	1 0,11
15,87	10	0.258 6,55	12	0.16 73	6 130 27,27	6 130 27,27	29 000 129,00	20 250 90,08	1/5 0,11/0,56	1 0,11
19,05	12	0.27 6,86	13	0.24 109	7 730 34,38	6 700 29,80	37 000 164,58	26 200 116,54	1/5 0,11/0,56	1 0,11
22,22	14	0.333 8,46	6	0.35 159	10 800 48,04	8 150 36,25	65 200 290,02	33 600 149,46	2/8 0,23/0,9	2 0,23
25,4	16	0.457 11,61	12	0.97 440	19 300 85,85	11 198 49,81	104 000 462,62	56 250 250,21	2/8 0,23/0,9	2 0,23

¹⁾ Values are given for non protected bearings. For sealed and shielded bearings, refer to page 149



Designation system

Examples: ZXRL19,05FRAXTTCP33RP01
 XRL 9,52FRPPCP109

Surface treatment of outer ring

No code Not plated
Z Cadmium plated external dimensions
SZ Zinc-nickel plated external dimensions

Basic designation

Bore code

Lined bore

No code Bore without liner
A¹⁾ Lined bore

Starting torque

No code Standard
X Reduced

Shield and seal

No code No shield and seal
TT¹⁾ Sealed
PP¹⁾ Shielded

Material and surface treatment of inner ring

	Material	Surface treatment
No code	440C	Not plated
CP6	440C	Chromium plated sphere
CP109	440C	XCR plating on sphere (chromium 6 free replacement to chromium plating)
CP55	440C	Passivated inner ring
CP33	PH13.8	Not plated
CP194	PH13.8	Chromium plated sphere
CP195	PH13.8	XCR plating on sphere (chromium 6 free replacement to chromium plating)
CP196	PH13.8	Passivated inner ring

Oversize

No code Standard outer diameter size
RP01 0.010 in/0,254 mm oversized outer diameter
RP02 0.020 in/0,508 mm oversized outer diameter

¹⁾ Only available for $d \geq 7,94$

Cross-reference

Metal-to-metal spherical plain bearings

Metric bearings

2

EN part number	SKF designation
EN2335BPd'FR	WMASdRX-2 ²⁾
EN2335BPd'FR1	WMASdPRX-2 ²⁾
EN2335BPd'GR	WMACdRX-2 ²⁾
EN2335BPd'GR1	WMACdPRX-2 ²⁾
EN2335BPd'ER	WMAAdRX-2 ¹⁾
EN2335BPd'ER1	WMAAdPRX-2 ¹⁾
EN2335APd'FR	WMASdRX ²⁾
EN2335APd'FR1	WMASdPRX ²⁾
EN2335APd'GR	WMACdRX ²⁾
EN2335APd'GR1	WMACdPRX ²⁾
EN2335APd'ER	WMAAdRX ¹⁾
EN2335APd'ER1	WMAAdPRX ¹⁾
EN2335BPd'FS	WMASdX-2 ²⁾
EN2335BPd'GS	WMACdX-2 ²⁾
EN2335BPd'ES	WMAAdX-2
EN2335APd'FS	WMASdX ²⁾
EN2335APd'GS	WMACdX ²⁾
EN2335APd'ES	WMAAdX
EN2335BNd'FR	WMASdR-2 ²⁾
EN2335BNd'FR1	WMASdPR-2 ²⁾
EN2335BNd'GR	WMACdR-2 ²⁾
EN2335BNd'GR1	WMACdPR-2 ²⁾
EN2335BNd'ER	WMAAdR-2 ¹⁾
EN2335BNd'ER1	WMAAdPR-2 ¹⁾
EN2335ANd'FR	WMASdR ²⁾
EN2335ANd'FR1	WMASdPR ²⁾
EN2335ANd'GR	WMACdR ²⁾
EN2335ANd'GR1	WMACdPR ²⁾
EN2335ANd'ER	WMAAdR ¹⁾
EN2335ANd'ER1	WMAAdPR ¹⁾
EN2335BNd'FS	WMASd-2 ²⁾
EN2335BNd'GS	WMACd-2 ²⁾
EN2335BNd'ES	WMAAd-2
EN2335ANd'FS	WMASd ²⁾
EN2335ANd'GS	WMACd ²⁾
EN2335ANd'ES	WMAAd
EN2335BPd'FRT	WMASdRX-2CP55 ²⁾
EN2335BPd'FRT1	WMASdPRX-2CP55 ²⁾
EN2335BPd'GRT	WMACdRX-2CP55 ²⁾
EN2335BPd'GRT1	WMACdPRX-2CP55 ²⁾
EN2335BPd'ERT	WMAAdRX-2CP55 ¹⁾
EN2335BPd'ERT1	WMAAdPRX-2CP55 ¹⁾

EN part number	SKF designation
EN2335APd'FRT	WMASdRXCP55 ²⁾
EN2335APd'FRT1	WMASdPRXCP55 ²⁾
EN2335APd'GRT	WMACdRXCP55 ²⁾
EN2335APd'GRT1	WMACdPRXCP55 ²⁾
EN2335APd'ERT	WMAAdRXCP55 ¹⁾
EN2335APd'ERT1	WMAAdPRXCP55 ¹⁾
EN2335BPd'FST	WMASdX-2CP55 ²⁾
EN2335BPd'GST	WMACdX-2CP55 ²⁾
EN2335BPd'EST	WMAAdX-2CP55
EN2335APd'FST	WMASdXCP55 ²⁾
EN2335APd'GST	WMACdXCP55 ²⁾
EN2335APd'EST	WMAAdXCP55
EN2335BNd'FRT	WMASdR-2CP55 ²⁾
EN2335BNd'FRT1	WMASdPR-2CP55 ²⁾
EN2335BNd'GRT	WMACdR-2CP55 ²⁾
EN2335BNd'GRT1	WMACdPR-2CP55 ²⁾
EN2335BNd'ERT	WMAAdR-2CP55 ¹⁾
EN2335BNd'ERT1	WMAAdPR-2CP55 ¹⁾
EN2335ANd'FRT	WMASdRCP55 ²⁾
EN2335ANd'FRT1	WMASdPRCP55 ²⁾
EN2335ANd'GRT	WMACdRCP55 ²⁾
EN2335ANd'GRT1	WMACdPRCP55 ²⁾
EN2335ANd'ERT	WMAAdRCP55 ¹⁾
EN2335ANd'ERT1	WMAAdPRCP55 ¹⁾
EN2335BNd'FST	WMASd-2CP55 ²⁾
EN2335BNd'GST	WMACd-2CP55 ²⁾
EN2335BNd'EST	WMAAd-2CP55
EN2335ANd'FST	WMASdCP55 ²⁾
EN2335ANd'GST	WMACdCP55 ²⁾
EN2335ANd'EST	WMAAdCP55

Where
d = Bore code, with $d \leq 60$
d' = with a 0 replacing the space for $d \leq 8$
d for $d \geq 10$

¹⁾ Except for $d \leq 10$ ²⁾ Except for $d \leq 12$

Example

EN part number	SKF designation
EN2335BP 20 FR	WMAS 20 RX-2
EN2335AN 06 ES	WMA 6

EN part number	SKF designation
EN2336APd'E	GE d -C3A
EN2336APd'F	GES d -C3A
EN2336APd'G	GEC d -C3A
EN2336ANd'E	GE d D-C2A
EN2336ANd'F	GES d D-C2A
EN2336ANd'G	GEC d D-C2A
EN2336BPd'E	GE d -C3A-2
EN2336BPd'F	GES d -C3A-2
EN2336BPd'G	GEC d -C3A-2
EN2336BNd'E	GE d D-C2A-2
EN2336BNd'F	GES d D-C2A-2
EN2336BNd'G	GEC d D-C2A-2
EN2588APd'E	WGE d -C3A
EN2588APd'F	WGES d -C3A
EN2588APd'G	WGE d -C3A
EN2588ANd'E	WGE d D-C2A
EN2588ANd'F	WGES d D-C2A
EN2588ANd'G	WGE d D-C2A
EN2588BPd'E	WGE d -C3A-2
EN2588BPd'F	WGES d -C3A-2
EN2588BPd'G	WGE d -C3A-2
EN2588BNd'E	WGE d D-C2A-2
EN2588BNd'F	WGES d D-C2A-2
EN2588BNd'G	WGE d D-C2A-2
EN2588APd'ET	WGE d -C3ACP55
EN2588APd'FT	WGES d -C3ACP55
EN2588APd'GT	WGE d -C3ACP55
EN2588ANd'ET	WGE d D-C2ACP55
EN2588ANd'FT	WGES d D-C2ACP55
EN2588ANd'GT	WGE d D-C2ACP55
EN2588BPd'ET	WGE d -C3A-2CP55
EN2588BPd'FT	WGES d -C3A-2CP55
EN2588BPd'GT	WGE d -C3A-2CP55

EN part number	SKF designation
EN2588BNd'ET	WGE d D-C2A-2CP55
EN2588BNd'FT	WGES d D-C2A-2CP55
EN2588BNd'GT	WGE d D-C2A-2CP55

Where

d = Bore code, with $d \geq 5$

d' = d with a 0 replacing the space for $d \leq 8$
 d for $d \geq 10$

Example

EN part number	SKF designation
EN2336AP05G	GEC 5-C3A
EN2588BN40FT	WGES40D-C2A-2CP55

Inch bearings

2

EN part number	SKF designation
EN6046BNd'ERZ	ZENE d R-2
EN6046BNd'FRZ	ZENES d R-2
EN6046BNd'GRZ	ZENEC d R-2
EN6046BPd'ERZ	ZENE d RX-2
EN6046BPd'FRZ	ZENES d RX-2
EN6046BPd'GRZ	ZENEC d RX-2
EN6046ANd'ERZ	ZENE d R
EN6046ANd'FRZ	ZENES d R
EN6046ANd'GRZ	ZENEC d R
EN6046APd'ERZ	ZENE d RX
EN6046APd'FRZ	ZENES d RX
EN6046APd'GRZ	ZENEC d RX
EN6046BNd'ESZ	ZENE d -2
EN6046BNd'FSZ	ZENES d -2
EN6046BNd'GSZ	ZENEC d -2
EN6046BPd'ESZ	ZENE d X-2
EN6046BPd'FSZ	ZENES d X-2
EN6046BPd'GSZ	ZENEC d X-2
EN6046ANd'ESZ	ZENE d
EN6046ANd'FSZ	ZENES d
EN6046ANd'GSZ	ZENEC d
EN6046APd'ESZ	ZENE d X
EN6046APd'FSZ	ZENES d X
EN6046APd'GSZ	ZENEC d X
EN6046BNd'ER	ENE d R-2
EN6046BNd'FR	ENES d R-2
EN6046BNd'GR	ENEC d R-2
EN6046BPd'ER	ENE d RX-2
EN6046BPd'FR	ENES d RX-2
EN6046BPd'GR	ENEC d RX-2
EN6046ANd'ER	ENE d R
EN6046ANd'FR	ENES d R
EN6046ANd'GR	ENEC d R
EN6046APd'ER	ENE d RX
EN6046APd'FR	ENES d RX
EN6046APd'GR	ENEC d RX
EN6046BNd'ES	ENE d -2
EN6046BNd'FS	ENES d -2
EN6046BNd'GS	ENEC d -2

EN part number	SKF designation
EN6046BPd'ES	ENE d X-2
EN6046BPd'FS	ENES d X-2
EN6046BPd'GS	ENEC d X-2
EN6046ANd'ES	ENE d
EN6046ANd'FS	ENES d
EN6046ANd'GS	ENEC d
EN6046APd'ES	ENE d X
EN6046APd'FS	ENES d X
EN6046APd'GS	ENEC d X

Where
d = Bore code
d' = dash number (multiples of 1/16 inch)

Example

EN part number	SKF designation
EN6046BN 06 FRZ	ZENES 9,52 R-2
EN6046BP 14 GS	ENEC 22,22 X-2

EN part number	SKF designation
EN4265BPd'ER	ENL d RX-2
EN4265BPd'FR	ENLS d RX-2
EN4265BPd'GR	ENLC d RX-2
EN4265APd'ER	ENL d RX
EN4265APd'FR	ENLS d RX
EN4265APd'GR	ENLC d RX
EN4265BNd'ER	ENL d R-2
EN4265NPd'FR	ENLS d R-2
EN4265NPd'GR	ENLC d R-2
EN4265ANd'ER	ENL d R
EN4265ANd'FR	ENLS d R
EN4265ANd'GR	ENLC d R
EN4265BPd'ES	ENL d X-2
EN4265BPd'FS	ENLS d X-2
EN4265BPd'GS	ENLC d X-2
EN4265APd'ES	ENL d X
EN4265APd'FS	ENLS d X
EN4265APd'GS	ENLC d X

EN part number	SKF designation
EN4265BN d 'ES	ENL d -2
EN4265NP d 'FS	ENLS d -2
EN4265NP d 'GS	ENLC d -2
EN4265AN d 'ES	ENL d
EN4265AN d 'FS	ENLS d
EN4265AN d 'GS	ENLC d
EN4266BP d 'ER	ZENL d RX-2
EN4266BP d 'FR	ZENLS d RX-2
EN4266BP d 'GR	ZENLC d RX-2
EN4266AP d 'ER	ZENL d RX
EN4266AP d 'FR	ZENLS d RX
EN4266AP d 'GR	ZENLC d RX
EN4266BN d 'ER	ZENL d R-2
EN4266NP d 'FR	ZENLS d R-2
EN4266NP d 'GR	ZENLC d R-2
EN4266AN d 'ER	ZENL d R
EN4266AN d 'FR	ZENLS d R
EN4266AN d 'GR	ZENLC d R
EN4266BP d 'ES	ZENL d X-2
EN4266BP d 'FS	ZENLS d X-2
EN4266BP d 'GS	ZENLC d X-2
EN4266AP d 'ES	ZENL d X
EN4266AP d 'FS	ZENLS d X
EN4266AP d 'GS	ZENLC d X
EN4266BN d 'ES	ZENL d -2
EN4266NP d 'FS	ZENLS d -2
EN4266NP d 'GS	ZENLC d -2
EN4266AN d 'ES	ZENL d
EN4266AN d 'FS	ZENLS d
EN4266AN d 'GS	ZENLC d

Where
d = Bore code
d' = dash number (multiples of 1/16 inch)

Example

EN part number	SKF designation
EN4265BP 07 FR	ENLS 11,11 RX-2
EN4266AN 12 GS	ZENLC 19,05

AS part number	SKF designation
M81936/1- d 'RT	QXMC d RRP01
M81936/1- d 'RU	QXMC d RRP02
M81936/1- d 'R	QXMC d R
M81936/1- d 'T	QXMBY d RRP01
M81936/1- d 'U	QXMBY d RRP02
M81936/1- d '	QXMBY d R
M81936/2- d 'RT	QXMC d RP01
M81936/2- d 'RU	QXMC d RP02
M81936/2- d 'R	QXMC d R
M81936/2- d 'T	QXMBY d RP01
M81936/2- d 'U	QXMBY d RP02
M81936/2- d '	QXMBY d R

Where
d = Bore code
d' = dash number (multiples of 1/16 inch)

Example

AS part number	SKF designation
M81936/1- 4 RT	QXMC 6,35 RRP01
M81936/2- 12	QXMBY 19,05

AS part number	SKF designation
MS21154 Sd 'E	SZWMEY d R-4CP6
MS21154 Sd '	ZWMEY d R-4CP6
MS21154 Bd 'E	SZWQMEY d R-4CP6
MS21154 Bd '	ZWQMEY d R-4CP6
MS21155 Sd 'E	SZWMEY d -4CP6
MS21155 Sd '	ZWMEY d -4CP6
MS21155 Bd 'E	SZWQMEY d -4CP6
MS21155 Bd '	ZWQMEY d -4CP6

Where
d = Bore code, with $d \leq 25,4$
d' = dash number (multiples of 1/16 inch)

Example

AS part number	SKF designation
MS21154 S03 E	SZWMEY 4,83 R-4CP6
MS21155 B14	ZWQMEY 22,22 -4CP6

Self-lubricating spherical plain bearings

Metric bearings

2

EN part number	SKF designation
EN3048S d PA ¹⁾	LEN d F
EN3048S d TA ¹⁾	LEN d V
EN3048S d A ¹⁾	LEN d
EN3048R d PA ¹⁾	LEN d RF
EN3048R d TA ¹⁾	LEN d RV
EN3048R d A ¹⁾	LEN d R
EN3048R d PA ¹⁾	LEN d PRF
EN3048R d TA ¹⁾	LEN d PRV
EN3048R d A ¹⁾	LEN d PR
EN 4037S d T ¹⁾	LEN d XV
EN 4037S d A ¹⁾	LEN d X
EN 4037R d T ¹⁾	LEN d RXV
EN 4037R d A ¹⁾	LEN d RX
EN3048S15PA	LEN15/26F
EN3048S15TA	LEN15/26V
EN3048S15A	LEN15/26
EN3048R15PA	LEN15/26RF
EN3048R15TA	LEN15/26RV
EN3048R15A	LEN15/26R
EN3048R15PA1	LEN15/26PRF
EN3048R15TA1	LEN15/26PRV
EN3048R15A1	LEN15/26PR
EN 4037S15T	LEN15/26XV
EN 4037S15	LEN15/26X
EN 4037R15T	LEN15/26RXV
EN 4037R15	LEN15/26RX
EN3048S17PA	LEN17/30F
EN3048S17TA	LEN17/30V
EN3048S17A	LEN17/30
EN3048R17PA	LEN17/30RF
EN3048R17TA	LEN17/30RV
EN3048R17A	LEN17/30R
EN3048R17PA1	LEN17/30PRF

EN part number	SKF designation
EN3048R17TA1	LEN17/30PRV
EN3048R17A1	LEN17/30PR
EN 4037S17T	LEN17/30XV
EN 4037S17	LEN17/30X
EN 4037R17T	LEN17/30RXV
EN 4037R17	LEN17/30RX

Where

d = Bore code, with $d \leq 50$ ¹⁾ Except for $d = 15$ and $d = 17$.**Example**

EN part number	SKF designation
EN3048S 12 PA	LEN 12 F
EN3048R 15 TA1	LEN 15/26 PRV
EN 4037R 35	LEN 35 RX

EN part number	SKF designation
EN2584S d PA	NEN d F
EN2584S d TA	NEN d V
EN2584S d A	NEN d
EN2584R d PA	NEN d RF
EN2584R d TA	NEN d RV
EN2584R d A	NEN d R
EN 4038S d T	NEN d XV
EN 4038S d	NEN d X
EN 4038R d T	NEN d RXV
EN 4038R d	NEN d RX

Where

d = Bore code**Example**

EN part number	SKF designation
EN2584S 05 PA	NEN 05 F
EN 4038S 12	NEN 12 X

EN part number	SKF designation
EN2585S d PA	WEN d F ¹⁾
EN2585S d TA	WEN d V ¹⁾
EN2585S d A	WEN d ¹⁾
EN2585R d PA	WEN d RF ¹⁾
EN2585R d TA	WEN d RV ¹⁾
EN2585R d A	WEN d R ¹⁾
EN 4039S d T	WEN d XV (For $d \geq 6$ and $d \leq 50$)
EN 4039S d	WEN d X (For $d \geq 6$ and $d \leq 50$)
EN 4039R d T	WEN d RXV (For $d \geq 6$ and $d \leq 50$)
EN 4039R d	WEN d RX (For $d \geq 6$ and $d \leq 50$)

Where
d = Bore code

¹⁾ For $d \leq 55$.

Example

EN part number	SKF designation
EN2585S 05 PA	WEN 05 F
EN 4039R 20	WEN 20 RX

EN part number	SKF designation
EN4040S d' TN	HMEN d V
EN4040S d' TL	HMEN d XV
EN4040S d' N	HMEN d
EN4040S d' L	HMEN d X
EN4040R d' TN	HMEN d RV
EN4040R d' TL	HMEN d RXV
EN4040R d' N	HMEN d R
EN4040R d' L	HMEN d RX

Where
d' = 06 for bore code **d** = 06B
08 for bore code **d** = 08B
10 for bore code **d** = 10B

Example

EN part number	SKF designation
EN4040S 06 TN	HMEN 06 BV

Inch bearings

2

AS part number		SKF designation	
MS14101-5ACEKT for d= 5	MS14101-dCEKT ¹⁾	SZENASdRXY2	
MS14101-5ACEKU for d= 5	MS14101-dCEKU ¹⁾	SZENASdRXY4	
MS14101-5ACEK for d= 5	MS14101-dCEK ¹⁾	SZENASdRX	
MS14101-5ACET for d= 5	MS14101-dCET ¹⁾	SZENASdRY2	
MS14101-5ACEU for d= 5	MS14101-dCEU ¹⁾	SZENASdRY4	
MS14101-5ACE for d= 5	MS14101-dCE ¹⁾	SZENASdR	
MS14101-5ACKT for d= 5	MS14101-dCKT ¹⁾	ENASdRXY2	
MS14101-5ACKU for d= 5	MS14101-dCKU ¹⁾	ENASdRXY4	
MS14101-5ACK for d= 5	MS14101-dCK ¹⁾	ENASdRX	
MS14101-5ACT for d= 5	MS14101-dCT ¹⁾	ENASdRY2	
MS14101-5ACU for d= 5	MS14101-dCU ¹⁾	ENASdRY4	
MS14101-5AC for d= 5	MS14101-dC ¹⁾	ENASdR	
MS14101-5ACPKT for d= 5	MS14101-dCPKT ¹⁾	ZENASdRXY2	SZENASdRXY2
MS14101-5ACP KU for d= 5	MS14101-dCPKU ¹⁾	ZENASdRXY4	SZENASdRXY4
MS14101-5ACPK for d= 5	MS14101-dCPK ¹⁾	ZENASdRX	SZENASdRX
MS14101-5ACPT for d= 5	MS14101-dCPT ¹⁾	ZENASdRY2	SZENASdRY2
MS14101-5ACPU for d= 5	MS14101-dCPU ¹⁾	ZENASdRY4	SZENASdRY4
MS14101-5ACP for d= 5	MS14101-dCP ¹⁾	ZENASdR	SZENASdR
MS14101-5AEKT for d= 5	MS14101-dEKT ¹⁾	SZNASdRXY2	
MS14101-5AEKU for d= 5	MS14101-dEKU ¹⁾	SZNASdRXY4	
MS14101-5AEK for d= 5	MS14101-dEK ¹⁾	SZNASdRX	
MS14101-5AET for d= 5	MS14101-dET ¹⁾	SZNASdRY2	
MS14101-5AEU for d= 5	MS14101-dEU ¹⁾	SZNASdRY4	
MS14101-5AE for d= 5	MS14101-dE ¹⁾	SZNASdR	
MS14101-5AKT for d= 5	MS14101-dKT ¹⁾	NASdRXY2	
MS14101-5AKU for d= 5	MS14101-dKU ¹⁾	NASdRXY4	
MS14101-5AK for d= 5	MS14101-dK ¹⁾	NASdRX	
MS14101-5AT for d= 5	MS14101-dT ¹⁾	NASdRY2	
MS14101-5AU for d= 5	MS14101-dU ¹⁾	NASdRY4	
MS14101-5A for d= 5	MS14101-d ¹⁾	NASdR	
MS14101-5APKT for d= 5	MS14101-dPKT ¹⁾	ZNASdRXY2	SZNASdRXY2
MS14101-5APKU for d= 5	MS14101-dPKU ¹⁾	ZNASdRXY4	SZNASdRXY4
MS14101-5APK for d= 5	MS14101-dPK ¹⁾	ZNASdRX	SZNASdRX
MS14101-5APT for d= 5	MS14101-dPT ¹⁾	ZNASdRY2	SZNASdRY2
MS14101-5APU for d= 5	MS14101-dPU ¹⁾	ZNASdRY4	SZNASdRY4
MS14101-5AP for d= 5	MS14101-dP ¹⁾	ZNASdR	SZNASdR
MS14104-dCEKT		SZENASdXY2	
MS14104-dCEKU		SZENASdXY4	
MS14104-dCEK		SZENASdX	
MS14104-dCET		SZENASdY2	
MS14104-dCEU		SZENASdY4	
MS14104-dCE		SZENASd	

AS part number	SKF designation	
MS14104- d CKT MS14104- d CKU MS14104- d CK	ENAS d XY2 ENAS d XY4 ENAS d X	
MS14104- d CT MS14104- d CU MS14104- d C	ENAS d Y2 ENAS d Y4 ENAS d	
MS14104- d CPKT MS14104- d CPKU MS14104- d CPK	ZENAS d XY2 ZENAS d XY4 ZENAS d X	SZENAS d XY2 SZENAS d XY4 SZENAS d X
MS14104- d CPT MS14104- d CPU MS14104- d CP	ZENAS d Y2 ZENAS d Y4 ZENAS d	SZENAS d Y2 SZENAS d Y4 SZENAS d
MS14104- d EKT MS14104- d EKU MS14104- d EK	SZNAS d XY2 SZNAS d XY4 SZNAS d X	
MS14104- d ET MS14104- d EU MS14104- d E	SZNAS d Y2 SZNAS d Y4 SZNAS d	
MS14104- d KT MS14104- d KU MS14104- d K	NAS d XY2 NAS d XY4 NAS d X	
MS14104- d T MS14104- d U MS14104- d	NAS d Y2 NAS d Y4 NAS d	
MS14104- d PKT MS14104- d PKU MS14104- d PK	ZNAS d XY2 ZNAS d XY4 ZNAS d X	SZNAS d XY2 SZNAS d XY4 SZNAS d X
MS14104- d P MS14104- d PT MS14104- d PU MS14104- d P	ZNAS d Y2 ZNAS d Y4 ZNAS d	SZNAS d Y2 SZNAS d Y4 SZNAS d

Where

d = Bore code, with $d \leq 16$

1) Except for $d = 5$

Example

AS part number	SKF designation	
MS14101- 3 CEKT MS14101- 10 PK MS14104- 6 KU MS14104- 12 P	SZENAS 3 RXY2 ZNAS 10 RX NAS 6 XY4 ZNAS 12	SZENAS 10 RX SZNAS 12

2 Self-lubricating spherical plain bearings

2

AS part number	SKF designation		
MS14103-dCEKT	SZEWASdRXY2		
MS14103-dCEKU	SZEWASdRXY4		
MS14103-dCEK	SZEWASdRX		
MS14103-dCET	SZEWASdRY2		
MS14103-dCEU	SZEWASdRY4		
MS14103-dCE	SZEWASdR		
MS14103-dCKT	EWASdRXY2		
MS14103-dCKU	EWASdRXY4		
MS14103-dCK	EWASdRX		
MS14103-dCT	EWASdRY2		
MS14103-dCU	EWASdRY4		
MS14103-dC	EWASdR		
MS14103-dCPKT	ZEWASdRXY2	SZEWASdRXY2	
MS14103-dCPKU	ZEWASdRXY4	SZEWASdRXY4	
MS14103-dCPK	ZEWASdRX	SZEWASdRX	
MS14103-dCPT	ZEWASdRY2	SZEWASdRY2	
MS14103-dCPU	ZEWASdRY4	SZEWASdRY4	
MS14103-dCP	ZEWASdR	SZEWASdR	
MS14103-dEKT	SZWASdRXY2		
MS14103-dEKU	SZWASdRXY4		
MS14103-dEK	SZWASdRX		
MS14103-dET	SZWASdRY2		
MS14103-dEU	SZWASdRY4		
MS14103-dE	SZWASdR		
MS14103-dKT	WASdRXY2		
MS14103-dKU	WASdRXY4		
MS14103-dK	WASdRX		
MS14103-dT	WASdRY2		
MS14103-dU	WASdRY4		
MS14103-d	WASdR		
MS14103-dPKT	ZWASdRXY2	SZWASdRXY2	
MS14103-dPKU	ZWASdRXY4	SZWASdRXY4	
MS14103-dPK	ZWASdRX	SZWASdRX	
MS14103-dPT	ZWASdRY2	SZWASdRY2	
MS14103-dPU	ZWASdRY4	SZWASdRY4	
MS14103-dP	ZWASdR	SZWASdR	
MS14102-dCEKT	SZEWASdXY2		
MS14102-d'CEKU	SZEWASdXY4		
MS14102-dCEK	SZEWASdX		
MS14102-dCET	SZEWASdY2		
MS14102-dCEU	SZEWASdY4		
MS14102-dCE	SZEWASd		

AS part number	SKF designation		
MS14102-d'CKT	EWASdXY2		
MS14102-dCKU	EWASdXY4		
MS14102-dCK	EWASdX		
MS14102-dCT	EWASdY2		
MS14102-dCU	EWASdY4		
MS14102-dC	EWASd		
MS14102-dCPKT	ZEWASdXY2	SZEWASdXY2	
MS14102-dCPKU	ZEWASdXY4	SZEWASdXY4	
MS14102-dCPK	ZEWASdX	SZEWASdX	
MS14102-dCPT	ZEWASdY2	SZEWASdY2	
MS14102-dCPU	ZEWASdY4	SZEWASdY4	
MS14102-dCP	ZEWASd	SZEWASd	
MS14102-dEKT	SZWASdXY2		
MS14102-dEKU	SZWASdXY4		
MS14102-dEK	SZWASdX		
MS14102-dET	SZWASdY2		
MS14102-dEU	SZWASdY4		
MS14102-dE	SZWASd		
MS14102-dKT	WASdXY2		
MS14102-dKU	WASdXY4		
MS14102-dK	WASdX		
MS14102-dT	WASdY2		
MS14102-dU	WASdY4		
MS14102-d	WASd		
MS14102-dPKT	ZWASdXY2	SZWASdXY2	
MS14102-dPKU	ZWASdXY4	SZWASdXY4	
MS14102-dPK	ZWASdX	SZWASdX	
MS14102-dPT	ZWASdY2	SZWASdY2	
MS14102-dPU	ZWASdY4	SZWASdY4	
MS14102-dP	ZWASd	SZWASd	

Where
d = Bore code, with $d \leq 16$

Example

AS part number	SKF designation		
MS14103-3CEKT	SZEWAS3RXY2		
MS14103-10CP	ZEWAS10R	SZEWAS10R	
MS14102-6KU	WAS6XY4		
MS14102-12P	ZWAS12	SZWAS12	

AS part number	SKF designation	
M81820/1-dEKT	SZENASdARXY2	
M81820/1-dEKU	SZENASdARXY4	
M81820/1-dEK	SZENASdARX	
M81820/1-dET	SZENASdARY2	
M81820/1-dEU	SZENASdARY4	
M81820/1-dE	SZENASdAR	
M81820/1-dKT	ENASdARXY2	
M81820/1-dKU	ENASdARXY4	
M81820/1-dK	ENASdARX	
M81820/1-dT	ENASdARY2	
M81820/1-dU	ENASdARY4	
M81820/1-d	ENASdAR	
M81820/1-dPKT	ZENASdARXY2	SZENASdARXY2
M81820/1-dPKU	ZENASdARXY4	SZENASdARXY4
M81820/1-dPK	ZENASdARX	SZENASdARX
M81820/1-dPT	ZENASdARY2	SZENASdARY2
M81820/1-dPU	ZENASdARY4	SZENASdARY4
M81820/1-dP	ZENASdAR	SZENASdAR
M81820/1-dEKTd	SZNASdARXY2	
M81820/1-dEKUD	SZNASdARXY4	
M81820/1-dEKD	SZNASdARX	
M81820/1-dETd	SZNASdARY2	
M81820/1-dEUD	SZNASdARY4	
M81820/1-dED	SZNASdAR	
M81820/1-dKTD	NASdARXY2	
M81820/1-dKUD	NASdARXY4	
M81820/1-dKD	NASdARX	
M81820/1-dTD	NASdARY2	
M81820/1-dUD	NASdARY4	
M81820/1-dD	NASdAR	
M81820/1-dPKTD	ZNASdARXY2	SZNASdARXY2
M81820/1-dPKUD	ZNASdARXY4	SZNASdARXY4
M81820/1-dPKD	ZNASdARX	SZNASdARX
M81820/1-dPTD	ZNASdARY2	SZNASdARY2
M81820/1-dPUD	ZNASdARY4	SZNASdARY4
M81820/1-dPD	ZNASdAR	SZNASdAR
M81820/4-dEKT	SZENASdAXY2	
M81820/4-dEKU	SZENASdAXY4	
M81820/4-dEK	SZENASdAX	
M81820/4-dET	SZENASdAY2	
M81820/4-dEU	SZENASdAY4	
M81820/4-dE	SZENASdA	

AS part number	SKF designation	
M81820/4-dKT	ENASdAXY2	
M81820/4-dKU	ENASdAXY4	
M81820/4-dK	ENASdAX	
M81820/4-dT	ENASdAY2	
M81820/4-dU	ENASdAY4	
M81820/4-d	ENASdA	
M81820/4-dPKT	ZENASdAXY2	SZENASdAXY2
M81820/4-dPKU	ZENASdAXY4	SZENASdAXY4
M81820/4-dPK	ZENASdAX	SZENASdAX
M81820/4-dPT	ZENASdAY2	SZENASdAY2
M81820/4-dPU	ZENASdAY4	SZENASdAY4
M81820/4-dP	ZENASdA	SZENASdA
M81820/4-dEKTd	SZNASdAXY2	
M81820/4-dEKUD	SZNASdAXY4	
M81820/4-dEKD	SZNASdAX	
M81820/4-dETd	SZNASdAY2	
M81820/4-dEUD	SZNASdAY4	
M81820/4-dED	SZNASdA	
M81820/4-dKTD	NASdAXY2	
M81820/4-dKUD	NASdAXY4	
M81820/4-dKD	NASdAX	
M81820/4-dTD	NASdAY2	
M81820/4-dUD	NASdAY4	
M81820/4-dD	NASdA	
M81820/4-dPKTD	ZNASdAXY2	SZNASdAXY2
M81820/4-dPKUD	ZNASdAXY4	SZNASdAXY4
M81820/4-dPKD	ZNASdAX	SZNASdAX
M81820/4-dPTD	ZNASdAY2	SZNASdAY2
M81820/4-dPUD	ZNASdAY4	SZNASdAY4
M81820/4-dPD	ZNASdA	SZNASdA

Where
d = Bore code, with $4 \leq d \leq 16$

Example

AS part number	SKF designation	
M81820/1-5EKT	SZENAS5ARXY2	
M81820/1-10PK	ZENAS10ARX	SZENAS10ARX
M81820/4-6UD	NAS6AY4	
M81820/4-12PD	ZNAS12A	SZNAS12A

2 Self-lubricating spherical plain bearings

2

AS part number	SKF designation	
M81820/3-dEKT	SZEWA d ARXY2	
M81820/3-dEKU	SZEWA d ARXY4	
M81820/3-dEK	SZEWA d ARX	
M81820/3-dET	SZEWA d ARY2	
M81820/3-dEU	SZEWA d ARY4	
M81820/3-dE	SZEWA d AR	
M81820/3-dKT	EWA d ARXY2	
M81820/3-dKU	EWA d ARXY4	
M81820/3-dK	EWA d ARX	
M81820/3-dT	EWA d ARY2	
M81820/3-dU	EWA d ARY4	
M81820/3-d	EWA d AR	
M81820/3-dPKT	ZEWA d ARXY2	SZEWA d ARXY2
M81820/3-dPKU	ZEWA d ARXY4	SZEWA d ARXY4
M81820/3-dPK	ZEWA d ARX	SZEWA d ARX
M81820/3-dPT	ZEWA d ARY2	SZEWA d ARY2
M81820/3-dPU	ZEWA d ARY4	SZEWA d ARY4
M81820/3-dP	ZEWA d AR	SZEWA d AR
M81820/3-dEKTd	SZWA d ARXY2	
M81820/3-dEKUD	SZWA d ARXY4	
M81820/3-dEKD	SZWA d ARX	
M81820/3-dETD	SZWA d ARY2	
M81820/3-dEUD	SZWA d ARY4	
M81820/3-dED	SZWA d AR	
M81820/3-dKTD	WA d ARXY2	
M81820/3-dKUD	WA d ARXY4	
M81820/3-dKD	WA d ARX	
M81820/3-dTD	WA d ARY2	
M81820/3-dUD	WA d ARY4	
M81820/3-dD	WA d AR	
M81820/3-dPKTD	ZWA d ARXY2	SZWA d ARXY2
M81820/3-dPKUD	ZWA d ARXY4	SZWA d ARXY4
M81820/3-dPKD	ZWA d ARX	SZWA d ARX
M81820/3-dPTD	ZWA d ARY2	SZWA d ARY2
M81820/3-dPUD	ZWA d ARY4	SZWA d ARY4
M81820/3-dPD	ZWA d AR	SZWA d AR
M81820/2-dEKT	SZEWA d AXY2	
M81820/2-dEKU	SZEWA d AXY4	
M81820/2-dEK	SZEWA d AX	
M81820/2-dET	SZEWA d AY2	
M81820/2-dEU	SZEWA d AY4	
M81820/2-dE	SZEWA d A	

AS part number	SKF designation	
M81820/2-dKT	EWA d AXY2	
M81820/2-dKU	EWA d AXY4	
M81820/2-dK	EWA d AX	
M81820/2-dT	EWA d AY2	
M81820/2-dU	EWA d AY4	
M81820/2-d	EWA d A	
M81820/2-dPKT	ZEWA d AXY2	SZEWA d AXY2
M81820/2-dPKU	ZEWA d AXY4	SZEWA d AXY4
M81820/2-dPK	ZEWA d AX	SZEWA d AX
M81820/2-dPT	ZEWA d AY2	SZEWA d AY2
M81820/2-dPU	ZEWA d AY4	SZEWA d AY4
M81820/2-dP	ZEWA d A	SZEWA d A
M81820/2-dEKTd	SZWA d AXY2	
M81820/2-dEKUD	SZWA d AXY4	
M81820/2-dEKD	SZWA d AX	
M81820/2-dETD	SZWA d AY2	
M81820/2-dEUD	SZWA d AY4	
M81820/2-d'ED	SZWA d A	
M81820/2-dKTD	WA d AXY2	
M81820/2-dKUD	WA d AXY4	
M81820/2-dKD	WA d AX	
M81820/2-dTD	WA d AY2	
M81820/2-dUD	WA d AY4	
M81820/2-dD	WA d A	
M81820/2-dPKTD	ZWA d AXY2	SZWA d AXY2
M81820/2-dPKUD	ZWA d AXY4	SZWA d AXY4
M81820/2-dPKD	ZWA d AX	SZWA d AX
M81820/2-dPTD	ZWA d AY2	SZWA d AY2
M81820/2-dPUD	ZWA d AY4	SZWA d AY4
M81820/2-dPD	ZWA d A	SZWA d A

Where

d = Bore code, with 5 ≤ d ≤ 16

Example

AS part number	SKF designation	
M81820/3- 5 EKT	SZEWA 5 ARXY2	
M81820/3- 10 PKU	ZEWA 10 ARXY4	SZEWA 10 ARXY4
M81820/2- 6 EUD	SZWA 6 AY4	
M81820/2- 12 PD	ZWA 12 A	SZWA 12 A

NSA part number	SKF designation
NSA8134- d 'X	SN d ZX ¹⁾
NSA8134- d '	SN d Z ¹⁾
NSA8136- d 'X	SN d GX ¹⁾
NSA8136- d '	SN d G ¹⁾

Where
d = Bore code (multiples of 1/16 inch)
d' = d for d ≤ 20
 28 for d = 28PR

¹⁾ Except for d = 24, d = 28 and d = 32

Example

NSA part number	SKF designation
NSA8134- 04 X	SN 04 ZX
NSA8136- 10	SN 10 G

NSA part number	SKF designation
NSA8135- d X	SW d ZX
NSA8135- d	SW d Z
NSA8137- d X	SW d GX
NSA8137- d	SW d G

Where
d = Bore code (multiples of 1/16 inch)

Example

NSA part number	SKF designation
NSA8135- 04 X	SW 04 ZX
NSA8137- 10	SW 10 G



Rod ends



3 Rod ends

Designs and variants	282	3.10 External thread inserted high misalignment metal-to-metal spherical plain bearing rod end.	314
Optional SKF design features	284	3.11 External thread inserted self-lubricating spherical plain bearing rod end.	316
Customized rod ends	284	3.12 Internal thread inserted wide self-lubricating spherical plain bearing rod end	318
Rod end bearing types selection criteria	284	3.13 Internal thread inserted high misalignment self-lubricating spherical plain bearing rod end	320
General specifications	285	Inch dimensions	322
Ball bearing rod ends	285	3.14 External thread rod end with integrated rolling bearing.	322
Design	285	3.15 External thread rod end with integrated rolling bearing, EN 4156, EN 4157	326
Selecting rod end size and options	285	3.16 External thread rod end with integrated rolling bearing, AS 21151	332
Lubrication	285	3.17 Internal thread rod end with integrated rolling bearing, AS 21153	334
Operating temperature	285	3.18 External inserted wide metal-to-metal spherical plain bearing rod end.	336
Friction and torque	285	3.19 External thread rod end with inserted metal-to-metal high misalignment spherical plain bearing	338
Rod end data	286	3.20 Internal thread inserted wide metal-to-metal spherical plain bearing rod end	340
Metal-to-metal spherical plain bearing rod ends	287	3.21 Internal thread inserted high misalignment metal-to-metal spherical plain bearing rod end.	342
Design	287	3.22 External thread inserted wide self-lubricating spherical plain bearing rod end, AS 81935/1	344
Selecting rod end size and options	287	3.23 External thread inserted wide self-lubricating spherical plain bearing rod end, AS 81935/4	346
Lubrication	288	3.24 External thread inserted narrow self-lubricating spherical plain bearing rod end, AS 81935/6	348
Internal clearance	289	3.25 External thread inserted narrow self-lubricating spherical plain bearing rod end, AS 81935/8	350
Operating temperature	289	3.26 External thread self-lubricating spherical plain bearing rod end, NSA 8143	352
Rod end data	289	3.27 External thread inserted wide self-lubricating spherical plain bearing rod end	354
Self-lubricating spherical plain bearing rod ends	291	3.28 External thread inserted self-lubricating spherical plain bearing rod end.	356
Design	291	3.29 Internal thread inserted wide self-lubricating spherical plain bearing rod end, AS 81935/2	358
Selecting rod end size and options	291	3.30 Internal thread inserted wide self-lubricating spherical plain bearing rod end, AS 81935/5	362
Friction and torque	291	3.31 Internal thread inserted narrow self-lubricating spherical plain bearing rod end, AS 81935/7.	366
Operating temperature	291	3.32 Internal thread inserted narrow self-lubricating spherical plain bearing rod end, AS 81935/9	370
Rod end data	291	3.33 Internal thread inserted self-lubricating spherical plain bearing rod end.	374
Rod end bodies	292	3.34 Internal thread inserted wide self-lubricating spherical plain bearing rod end	378
Rod end body load carrying capability	292	3.35 Internal thread inserted high misalignment self-lubricating spherical plain bearing rod end	380
Rod end head shape	293	Cross-reference	382
Rod end body features	293	Ball bearing rod ends	382
Bearing handling	294	Self-lubricating spherical plain bearing rod ends	386
Mounting	294		
Dismounting	294		
Storage	294		
Customized products	295		
Legacy products	295		
Legacy standards	295		
Product tables			
Metric dimensions	296		
3.1 External thread rod end with integrated rolling bearing, EN 3541, EN 4036	296		
3.2 External thread rod end with integrated rolling bearing.	298		
3.3 External thread integrated metal-to-metal spherical plain bearing rod end.	300		
3.4 External thread inserted wide metal-to-metal spherical plain bearing rod end.	302		
3.5 External thread inserted high misalignment metal-to-metal spherical plain bearing rod end.	304		
3.6 Internal thread rod end with integrated metal-to-metal spherical plain bearing	306		
3.7 Internal thread inserted wide metal-to-metal spherical plain bearing rod end	308		
3.8 Internal thread inserted high misalignment metal-to-metal spherical plain bearing rod end.	310		
3.9 External thread rod end with integrated rolling bearing.	312		

3 Rod ends

Rod ends are ready-to-mount airframe bearing solutions with threaded shanks. They provide the same functions as the bearing they use, together with an easy attachment and positioning solution to the application. Rod ends are available with spherical plain bearings or rolling bearings.

Refer to *Rod end bearing types selection criteria* page 284.

The standard range of SKF rod ends is tailored to meet a variety of operating conditions:

- Load: from low to high, for static or dynamic conditions
- Motion: from quasi-static to highly dynamic, including low to high frequency oscillation
- Environment: for a range of operating temperatures and environmental conditions

Airframe rod ends are used widely in aircraft structures and dynamic systems. They can be found in many applications including:

- Flight controls
- Actuators, attachment points and hinges
- Doors
- Helicopter rotors

SKF application engineers can provide additional help to select the most suitable standard rod end solution or design a customized rod end to meet your application requirements.

Designs and variants

The standard assortment of SKF rod ends is comprised of:

- Rod ends with integrated self-aligning ball bearings
- Rod ends with integrated metal-to-metal spherical plain bearings
- Rod ends with inserted metal-to-metal or self-lubricating spherical plain bearings

See **figure 1**.

For detailed information about which type of bearing is most suitable for a given application, refer to *Rod end bearing types selection criteria* page 284.

The SKF standard range of rod ends is listed in **table 1** for metric rod ends and in **table 2** for inch sizes.

Figure 1

Terminology

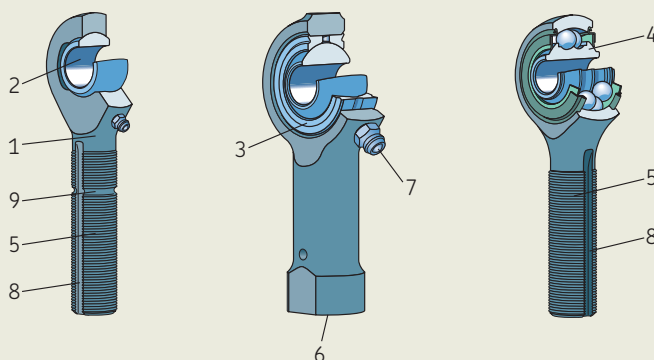

- 1 Rod end body
- 2 Integrated metal-to-metal spherical plain bearing
- 3 Inserted spherical plain bearing
- 4 Integrated rolling bearing
- 5 Rod end shank with external (male) thread
- 6 Rod end shank with internal (female) thread
- 7 Grease fitting
- 8 Keyway (vertical groove)
- 9 Locating groove (horizontal groove)

Table 1

SKF rod ends, metric dimensions

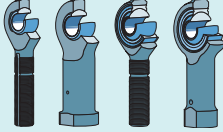
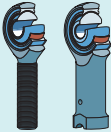
Type		Thread	Standard	SKF rod end series	SKF bearing series	Table number	Page	
Ball bearing rod ends		Integrated	External	EN 3541, EN 4036	C..MJ, CN..MJ	N/A	3.1	296
		Integrated	External	–	C..M, CN..M, CN..M..SP1	N/A	3.2	298
Metal-to-metal rod ends		Integrated	External	–	EM..	N/A	3.3	300
		Inserted	External	–	EMJ/ML..	ML..R metric	3.4	302
		Inserted	External	–	EMJ/MT..	MT..R metric	3.5	304
		Integrated	Internal	–	EF..	N/A	3.6	306
		Inserted	Internal	–	EFJ/ML..	ML..R metric	3.7	308
		Inserted	Internal	–	EFJ/MT..	MT..R metric	3.8	310
Self-lubricating rod ends		Inserted	External	EN 2498, EN 4198	EMA..	HMEN..R metric	3.9	312
		Inserted	External	–	EMJ/RL..	WEN..R metric	3.10	314
		Inserted	External	–	EMJ/RT..	XRT..R metric	3.11	316
		Inserted	Internal	–	EFJ/RL..	WEN..R metric	3.12	318
		Inserted	Internal	–	EFJ/RT..	XRT..R metric	3.13	320

3

Table 2

SKF rod ends, inch dimensions

Type		Thread	Standard	SKF rod end series	SKF bearing series	Table number	Page	
Ball bearing rod ends		Integrated	External	–	CN..SP	N/A	3.14	322
		Integrated	External	EN 4156, EN 4157	CN..	N/A	3.15	326
		Integrated	External	AS 21151	REP..M, RA..M, RAP..M	N/A	3.16	332
		Integrated	Internal	AS 21153	REP.., REP..F., REPB..N..	N/A	3.17	334
Metal-to-metal rod ends		Inserted	External	–	EMJ/..ML..R	ML..R inch	3.18	336
		Inserted	External	–	EMJ/..MT..R	MT..R inch	3.19	338
		Inserted	Internal	–	EFJ/..ML..R	ML..R inch	3.20	340
		Inserted	Internal	–	EFJ/..MT..R	MT..R inch	3.21	342
Self-lubricating rod ends		Inserted	External	AS 81935/1	MJ/WAS..	WAS..R inch, EWAS..R inch	3.22	344
		Inserted	External	AS 81935/4	MJ/NAS..	NAS..R inch, ENAS..R inch	3.23	346
		Inserted	External	AS 81935/6	PHMJ/WAS..	WAS..R inch, EWAS..R inch	3.24	348
		Inserted	External	AS 81935/8	PHMJ/NAS..	NAS..R inch, ENAS..R inch	3.25	350
		Inserted	External	NSA 8143	R..M..	SW..G inch	3.26	352
		Inserted	External	–	EMJ/RL..R	WAS..R inch	3.27	354
		Inserted	External	–	EMJ/RT..R	XRT..R inch	3.28	356
		Inserted	Internal	AS 81935/2	FJ/WAS..	WAS..R inch, EWAS..R inch	3.29	358
		Inserted	Internal	AS 81935/5	FJ/NAS..	NAS..R inch, ENAS..R inch	3.30	362
		Inserted	Internal	AS 81935/7	PHFJ/WAS..	WAS..R inch, EWAS..R inch	3.31	366
		Inserted	Internal	AS 81935/9	PHFJ/NAS..	NAS..R inch, ENAS..R inch	3.32	370
		Inserted	Internal	NSA 8149	R..F..	SW..G inch	3.33	374
		Inserted	Internal	–	EFJ/RL..R	WAS..R inch	3.34	378
Inserted	Internal	–	EFJ/RT..R	XRT..R inch	3.35	380		

Optional SKF design features

The standard assortment of SKF rod ends also includes a large variety of optional design features to meet specific application needs. The most common options are:

- Keyways or locating grooves in the rod end body for positioning, refer to **page 293**
- External (male) or internal (female) thread types to adapt to the application interface, refer to **page 293**
- Lubrication features, refer to **page 288**, Sealing solutions, refer to **pages 286, 290 and 292**, corrosion-resistant materials, refer to **pages 286, 289 and 291** and surface treatments, refer to **pages 286, 290 and 292** for optimal rod end performance in different operating conditions

Customized rod ends

SKF supplies customized and engineered rod ends to meet specific airframe application requirements. These solutions are the result of SKF's extensive experience and close cooperation between SKF and the customer's application experts.

SKF provides total solutions over the full bearing life cycle, including design, testing and partnership.

For additional information, refer to *Customized products* **page 295**.

Contact your regional SKF partner via: www.skf.com/go/aero.

Rod end bearing types selection criteria

The selection of the rod end type needed to meet the operating conditions depends mostly on the capabilities of the bearing type used in the rod end (rolling bearing, self-lubricating spherical plain bearing or metal-to-metal spherical plain bearing).

Refer to **table 11** in Airframe introduction **page 28** to select a bearing type (rolling or spherical plain bearing) that is suitable for the application requirements.

Then:

- For spherical plain bearings, refer to **table 2** in *Spherical plain bearings* **chapter page 131** for selection guidelines between metal-to-metal or self-lubricating bearing types
- For rolling bearings, refer to *Rolling bearings* **chapter page 30** for more information

With the selected bearing type, refer to the relevant rod end section for detailed information:

- *Ball bearing rod end* **page 285**
- *Metal-to-metal spherical plain bearing rod end* **page 287**
- *Self-lubricating spherical plain bearing rod end* **page 291**

General specifications

Ball bearing rod ends

Design

Ball bearing rod ends use an integrated self-aligning ball bearing. Where "integrated" means the balls run on a double row inner ring and a spherical raceway in the rod end head. For more information about self-aligning ball bearings, refer to *Rolling bearings* page 30.

Selecting rod end size and options

If you are looking for a known rod end, according to its standard for example, or if you are an experienced rod end and bearing expert, use **table 1** and **2** to find the relevant product table.

For help in selecting the appropriate rod end size and options, follow these steps:

- 1 Select external or internal thread type depending on the design of the application attachment point, refer to **page 293**
- 2 Determine the range of allowable interface dimensions for the rod end. Often the boundary dimensions are predetermined by the space available on the aircraft system. Typically, the shaft diameter determines the bore diameter.
- 3 Determine the static radial and axial loads *Rod end body load carrying capability* **page 292**.
- 4 Determine the swivelling angle capability required for the application.
- 5 From the product tables, find a rod end series with sufficient static load carrying capability and swivelling angle capability that best fits the required dimensions.

Example: When selecting a rod end with external thread, a maximum rod end length of 70 mm, a static radial limit load capacity of 3.5 kN and an axial static limit load capacity of 1 kN, then a C5MJ can be selected if the swivelling angle capability is sufficient.

- 6 Choose all other required options, including lubrication **page 285**, material **page 286** and surface treatment **page 286**.

If the standard SKF range of rolling bearing rod ends does not meet your specific needs, contact SKF for a customized products solution, as described in *Customized products* **page 295**.

Lubrication

Greases used in SKF ball bearing rod ends are listed in **table 3**. The standard grease options are listed in each relevant product table.

At least 80% of the free space in the bearing is filled with grease. The bearings are lubricated for life and cannot be relubricated.

Lubrication is primarily chosen according to the operating temperature.

For operation outside the allowable temperature range of the greases, the rod end and bearing life may be reduced. Contact SKF for more information.

Operating temperature

The permissible operating temperature of ball bearing rod ends is typically limited by the grease capability. Refer to *Lubrication* for more information about grease temperature limits.

Friction and torque

Values for rotational and swivelling starting torques, as defined in *Rolling bearings – Friction and torque* **page 41**, are listed in the relevant product tables.

3



Figure 2

Standard greases		
NATO codes	Standard	Operating temperature
G354	MIL PRF 23827 type I	-73 to +121 °C -100 to +250 °F
-	MIL PRF 23827 type II	-73 to +121 °C -100 to +250 °F
G395	MIL PRF 81322	-54 to +177 °C -64 to +350 °F

Rod end data

Material

The bodies of ball bearing rod ends use case hardening steel materials with a soft core and hard surface, providing increased mechanical resistance, see **table 4**.

Bearing inner ring and rolling elements use the standard materials defined in *Rolling bearings – Material* **page 45**: Bearing steel 100C6 or corrosion-resistant steel 440C.

The standard surface treatment options are zinc-nickel or cadmium plating. See the relevant product tables.

- Cadmium plating is applied according to AMS-QQ-P-416. This treatment can include chromium 6 compounds and may be subject to environmental legislation
- Zinc-nickel plating is a chromium 6 free alternative to cadmium plating, compliant to environmental legislation. Zinc-nickel plating is applied in accordance with AMS 2417

3

Surface treatment

Rod ends can be exposed to various environmental conditions including humidity, heat and fluids. These can limit the bearing life or performance by increasing the risk of contamination and corrosion.

Therefore, SKF supplies surface treatments for increased general corrosion resistance and increased fretting resistance.

These surface treatments are applied to the rod end body, but not to the raceways.

Rod end interface dimensions and tolerances from product tables are not modified when surface treatments are used.

For other surface treatments for specific purposes, refer to *Customized products* **page 295** and contact SKF.

Sealing solutions

Ball bearing rod ends are supplied as standard with shielding or sealing solutions as a protection against environmental conditions. For the design of the seal and shield, refer to *Rolling bearings – Sealing and shielding* **page 47**.

Table 4

Standard materials for ball bearing rod end bodies

Body material type	Raceway surface hardness HRC	Cross-sectional hardness HRC	Cross-sectional Rm MPa	Corrosion resistance	Material designation	EN	AMS	Equivalent designation
Case hardening alloy steel	For EN series ≥ 58 For AS series = 59 to 63 For other series ≥ 60	For AS series = 15 ¹⁾ to 45 for rod end shank and 32 to 48 for rod end head For other series = 20 to 40	For EN series > 830	Moderate	9315	EN 2099	AMS 6263	16NCD13
Case hardening corrosion-resistant steel	≥ 60	20 to 40	No standard requirement	Good	431	EN 3490	AMS 5628	Z15CN17.03

¹⁾ Equivalent to 92,5 HRB

Metal-to-metal spherical plain bearing rod ends

Design

Metal-to-metal rod ends consist of either:

- An integrated bearing, where "integrated" means the inner ring slides on a spherical surface machined in the rod end head. The rod end body serves as an outer ring (**figure 3**)
- A standard metal-to-metal spherical plain bearing inserted into a rod end body (**figure 4**)

Rod ends with integrated bearings have better fatigue resistance than the same size rod ends with inserted metal-to-metal spherical plain bearings. For more information refer to *Dynamic load for rod ends with inserted bearings* **page 292**.

Selecting rod end size and options

Integrated bearing

If you are looking for a known rod end or if you are an experienced rod end and bearing expert, use **table 1** and **2** to find the relevant product table.

For help in selecting the appropriate rod end size and options, follow these steps:

- 1 Select external or internal thread type depending on the design of the application attachment point, refer to **page 293**
- 2 Determine the range of allowable interface dimensions for the rod end. Often the boundary dimensions are predetermined by the space available on the aircraft system. Typically, the shaft diameter determines the bearing's bore diameter.
- 3 Determine the static radial and axial load requirements. For more information, refer to *Rod end body load carrying capability* **page 292**.
- 4 Determine the swivelling angle capability required for the application.
- 5 From the product tables, find a rod end series with sufficient static load carrying capability and swivelling angle capability that best fits the required dimensions.

Example

When selecting a rod end with external thread, a maximum rod end length of 160 mm and a static radial ultimate load capacity of 160 kN, then an EM20 can be selected if the swivelling angle capability is sufficient.

- 6 Depending on the operating and load conditions (static or dynamic), select an appropriate material and surface treatment combination. Integrated bearings with a bronze inner ring are typically used for endurance applications. Integrated bearings with a steel inner ring are typically used for static or fatigue applications. For more information, refer to *Metal-to-metal Spherical plain bearings – Dynamic load rating* **page 135**.
- 7 Choose all other options, including *Lubrication* **page 288** and *Sealing solutions* **page 290**.

If the standard SKF range of integrated metal-to-metal spherical plain bearing rod ends does not meet your specific needs, refer to the inserted *Metal-to-metal spherical plain bearing rod end* **chapter page 288** or contact SKF for a customized design solution as described in *Customized product* **page 295**.

Figure 3

Integrated metal-to-metal spherical plain bearing rod end



Figure 4

Inserted metal-to-metal spherical plain bearing rod end



Inserted bearing

If you are looking for a known rod end, or if you are an experienced rod end and bearing expert, use **table 1** and **2** to find the relevant product table.

For help in selecting the appropriate rod end size and options, follow these steps:

- 1 Select external or internal thread type depending on the design of the application attachment point, refer to **page 293**.
- 2 Use the metal-to-metal spherical plain bearing selection process **page 134** to select the most suitable bearing series and size required for the application.
- 3 Find the appropriate rod end series that uses the selected metal-to-metal bearing.
- 4 To select the rod end, confirm that the rod end load carrying capability is suitable for the application requirements. For more information, refer to *Rod end body load carrying capability* **page 292**.

5 If the rod end body's load carrying capability does not meet requirements, it is necessary to increase the bearing size and repeat the above steps.

6 Select all other options, including *Lubrication* **page 288**, *Materials* **page 289** and *Surface treatments* **page 290**.

If the standard SKF range of inserted metal-to-metal spherical plain bearing rod ends does not meet your specific needs, refer to the *Integrated metal-to-metal spherical plain bearing rod end* **chapter page 287** or contact SKF for a customized design solution as described in the *Customized products* **page 295**.

Lubrication

Metal-to-metal spherical plain bearing rod ends are supplied greased and ready to be put into operation.

They can be:

- Greased-for-life
 - This is especially suitable for static and fatigue loading conditions.
- Relubricated periodically
 - This is especially suitable for dynamic loading conditions such as endurance. To facilitate this operation, lubrication holes and grooves can be provided in the inner ring and/or in the outer ring and rod end body. Refer to *Lubrication grooves* **page 289**. For optimum bearing performance, relubrication should be performed frequently, for instance during planned aircraft maintenance.

Lubrication helps to:

- Reduce friction
- Reduce wear rate
- Reduce seizing risk
- Extend bearing service life
- Protect against corrosion
- Expel contaminants and wear debris

Table 5

Standard greases		
NATO codes	Standard	Operating temperature
G354	MIL PRF 23827 type I	-73 to +121 °C -100 to +250 °F
G395	MIL PRF 81322	-54 to +177 °C -64 to +350 °F

Figure 5

Lubrication grooves

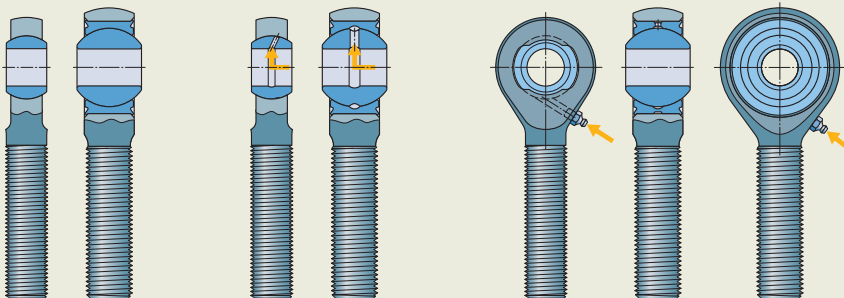

No code: Without lubrication groove

With system S:
Lubrication by
inner ring

With system C:
Lubrication by
rod end body

Lubricants

The greases used for standard metal-to-metal spherical plain bearing rod ends are listed in **table 5**.

Lubrication is primarily chosen according to the operating temperature.

WARNING: To prevent risk of bearing failure, use the same lubricant as supplied when relubricating.

Lubrication grooves

To facilitate lubricant supply to the sliding surfaces, metal-to-metal spherical plain bearing rod ends requiring periodic relubrication are available with relubrication grooves and holes in either the inner ring, the outer ring and rod end body, or both (**figure 5**). Available options are given in the relevant product tables.

Selection should be made according to the grease input locations:

- For grease inputs in the rod end head via a grease fitting, select code C. Standard grease fittings can be used such as AS 15001.
- For grease inputs in the shaft, select code S

Internal clearance

Inserted bearings are mounted and staked into the rod end body.

The staking can have an impact on the metal-to-metal spherical plain bearing clearance.

Internal clearances for the rod end assembly are listed in the relevant product tables.

For more information about metal-to-metal spherical plain bearing internal clearances, refer to *Internal clearance* **page 136**.

Operating temperature

The permissible operating temperature of standard metal-to-metal spherical plain bearing rod ends is limited by the grease capability, **table 5**.

For operation outside this temperature range, standard rod end and bearing life and performance may be reduced. Contact SKF for more information.

A wider operating temperature range can be achieved by using customized solutions (*Customized products* **page 295**).

Rod end data

Material

As specified in *Metal-to metal spherical plain bearing – Material* **page 138**, inserted and integrated metal-to-metal spherical plain bearings are available in the following materials:

- Bearing steel for high strength
- Corrosion-resistant steel for high strength and good corrosion resistance
- Copper alloys for good corrosion resistance and enhanced dynamic performance (For more information, refer to *Metal-to-metal Spherical plain bearings – Dynamic load rating* **page 135**)

The material of the rod end body is listed in the relevant product tables.

The typical material grades used by SKF metal-to-metal spherical plain bearing rod ends are listed in **table 6**.

Masses listed in the product tables are for rod ends made of steel materials. Titanium alloy is typically used for lightweight applications. With titanium alloy, the rod end body masses can be reduced by typically 55%.

Other materials are available on request. Refer to *Customized products* **page 295**.

Table 6

Standard materials for metal-to-metal spherical plain bearing rod end bodies

Rod end bearing type	Material type	Hardness HRC	Rm MPa	Corrosion resistance	Material designation	EN	AMS	Equivalent designation
Inserted and integrated	Alloy steel	No standard requirement	≥ 1080	Moderate	30NCD16	EN 2137, EN 2475	–	S97
	Corrosion resistant steel	35 to 42	≥ 1080	Good	17-4PH H1025	EN 2539, EN 3161	AMS 5643	Z6CNU17.04 H1025
Inserted	Titanium alloy	No standard requirement	900 to 1160	Very good	Ti6Al4V	EN 3311	AMS 4928	TA6V

Surface treatments

Rod ends can be exposed to various environmental conditions including humidity, heat and fluids. These can limit the bearing life or performance by increasing the risk of contamination and corrosion.

Therefore, SKF provides surface treatments for increased general corrosion resistance and increased fretting resistance.

The rod end body surface treatments are listed in the relevant product tables.

Alloy steel rod ends are cadmium plated¹⁾ or zinc-nickel plated.

Titanium rod ends are anodized as standard.

Inserted metal-to-metal spherical plain bearings can be protected as specified in *Metal-to-metal spherical plain bearing – Surface treatments* **page 139**.

Cadmium plating¹⁾ is applied in accordance with AMS-QQ-P-416 or AMS03-19²⁾.

Zinc-nickel plating is applied in accordance with AMS 2417.

Anodizing is applied in accordance with MIL-A-8625.

¹⁾ Treatment includes chromium 6 compounds and may be subject to environmental legislation.

²⁾ Formerly DEF STAN 03-19

Rod end interface dimensions and tolerances from product tables are not modified when surface treatments are used.

For other surface treatments for specific purposes, refer to *Customized products* **page 295** and contact SKF.

Sealing solutions

Rod ends with inserted metal-to-metal spherical plain bearings can be supplied with shielding or sealing solutions as a protection against environmental conditions. For the design of the seal and shield, refer to *Spherical plain bearing – Sealing and shielding* **page 140**.

SKF also supplies special sealing solutions for integrated rod ends operating under specific application conditions. Refer to *Customized products* **page 295**.

Figure 6

Self-lubricating spherical plain bearing rod end



Self-lubricating spherical plain bearing rod ends

Design

Self-lubricating rod ends consist of a self-lubricating spherical plain bearing inserted into a rod end body.

Selecting rod end size and options

If you are looking for a known rod end, according to its standard for example, or if you are an experienced rod end and bearing expert, use **table 1** and **2 page 283** to find the relevant product table.

For help in selecting the appropriate rod end size and options, follow these steps:

- 1 Select external or internal thread type depending on the design of the application attachment point, refer to **page 293**.
- 2 Use the self-lubricating spherical plain bearing selection process **page 142** to select the most suitable self-lubricating bearing series and size required for the application.
- 3 Find the appropriate rod end series that uses the selected self-lubricating bearing.

- 4 To select the rod end, confirm that the rod end load carrying capability is suitable for the application requirements. Refer to *Rod end body* **page 292**.
- 5 If the rod end body's load carrying capability does not meet requirements, it is necessary to increase the bearing size and repeat the above steps.

If the standard SKF range of self-lubricating spherical plain bearing rod ends does not meet your specific needs, contact SKF for a customized design solution, as described in the *Customized products* **page 295**.

Friction and torque

Inserted self-lubricating spherical plain bearings are mounted and staked into the rod end body.

The staking can have an impact on the self-lubricating spherical plain bearing torque. The resulting torque is listed in the relevant product tables.

WARNING: Self-lubricating spherical plain bearing rod ends must not be lubricated. This may result in damage to the liner and reduced rod end and bearing performance.

Operating temperature

The SKF self-lubricating rod ends have the same operating temperature range as the self-lubricating spherical plain bearing they incorporate.

Refer to *Spherical plain bearing – Operating temperature* **page 147**.

Rod end data

Material

Self-lubricating plain bearing materials are as specified in *Self-lubricating spherical plain bearing – Material* **page 148**:

Inner ring in corrosion-resistant steel 440C or PH13.8 and outer ring in corrosion-resistant-steel 17-4PH.

The material of the rod end body is given in the relevant product tables.

The typical material grades used by SKF self-lubricating spherical plain bearing rod ends are listed in **table 7**.

Masses listed in the product tables are for rod ends made of steel materials. Titanium alloy is typically used for lightweight applications. With titanium alloy, the rod end body masses can be reduced by typically 55%.

Other materials are available on request. Refer to *Customized products* **page 295**.

Table 7

Standard materials for self-lubricating spherical plain bearing rod end bodies

Material type	Hardness HRC	Rm MPa	Corrosion resistance	Material designation	EN	AMS	Equivalent designation
Alloy steel	For EN series = 33 to 39	≥ 1080	Moderate	30NCD16	EN 2137/ EN 2475	–	S97
	For AS series = 39 to 42 For other series, no standard requirement	39 to 42 ≥ 1080	Moderate	4340	–	AMS 6415, AMS-S-5000	40NCD7
Corrosion-resistant steel	35 to 42	≥ 1080	Good	17-4PH H1025	EN 2539/ EN 3161	AMS 5643	Z6CNU17.04 H1025
	40 to 44	No standard requirement	Good	PH13.8 H1050	–	AMS 5629	–
Titanium alloy	No standard requirement	900 to 1160	Very good	Ti6Al4V	EN 3311	AMS 4928	TA6V

Surface treatments

Rod ends can be exposed to various environmental conditions including humidity, heat and fluids. These can limit the bearing life or performance by increasing the risk of contamination and corrosion.

Therefore, SKF provides surface treatments for increased general corrosion resistance and increased fretting resistance.

The rod end body surface treatments are listed in the relevant product tables.

Alloy steel rod ends are cadmium plated¹⁾ or zinc-nickel plated.

Titanium rod ends are anodized as standard.

Corrosion-resistant steel rod ends can be passivated, as required by the relevant standards.

Passivation is applied in accordance with AMS 2700.

Cadmium plating¹⁾ is applied in accordance with AMS-QQ-P-416 or AMS03-19²⁾.

Zinc-nickel plating is applied in accordance with AMS 2417.

Self-lubricating spherical plain bearings can be protected as specified in *Self-lubricating spherical plain bearing – Surface treatment* **page 149**.

Rod end interface dimensions and tolerances from product tables are not modified when surface treatments are used.

For other surface treatments for specific purposes, refer to *Customized products* **page 295** and contact SKF.

¹⁾ Treatment includes chromium 6 compounds and may be subject to environmental legislation.

²⁾ Formerly DEF STAN 03-19

Sealing solutions

Rod ends with self-lubricating inserted spherical plain bearings can be supplied with shielding or sealing solutions as a protection against environmental conditions. For the design of the seal and shield, refer to the *Spherical plain bearing*, **chapter 2**.

Lined bore

SKF can supply self-lubricating rod ends with a self-lubricating liner in the bore. This is suitable for applications requiring axial movements along the shaft or when a secondary rotational motion in the bore is needed.

The considerations from *Spherical plain bearing – Lined Bore* **page 150**, are applicable.

Rod end bodies

Rod end body load carrying capability

Static load

The radial and axial static limit loads are listed in the relevant product tables for ball bearing rod ends.

The radial ultimate loads are listed in the relevant product tables for spherical plain bearing rod ends.

These values are valid for rod end bodies made of alloy steel or corrosion resistant steel.

For titanium rod end bodies, radial static ultimate loads are 70% of the equivalent steel rod end.

Dynamic load for rod ends with inserted bearings

Rod ends can support fatigue and endurance dynamic loading.

- Fatigue dynamic loading is when the load is alternating with no imposed swivelling or rotational movement.
- Endurance dynamic loading is when the load is applied constantly or alternating with swivelling and/or rotational movement. For rod ends with inserted bearings, it is the bearing that undergoes movement and withstands the endurance loading. The rod end itself only has to withstand a fatigue loading condition.

SKF standard rod ends are tested in fatigue dynamic loading conditions at a stress ratio, $R = 0,1$, see **diagram 1**. R is the ratio of the minimum applied load and the maximum applied load.

$$R = \frac{P_{\min}}{P_{\max}} = 0,1$$

Where:

R = Stress ratio

P_{\max} = Fatigue load carrying capability listed in the relevant product table [kN/lbf]

P_{\min} = 10% of the fatigue load carrying capability [kN/lbf]

Diagram 1

Fatigue load

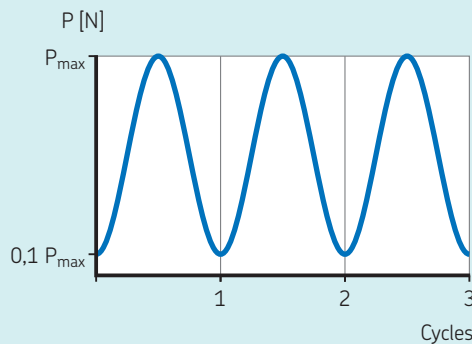

AS 81935³⁾ bearings are tested up to 50 000 load cycles. Other standard rod ends are tested up to 10⁶ cycles.

NOTE: For a given bearing type, rod ends with integrated bearings typically show better dynamic performance than the same size rod ends with inserted bearings. Contact SKF for more information.

³⁾ Bearings, plain, rod end, self-aligning, self-lubricating, general specification for -54 to 163 °C (-65 to +325 °F)

Rod end head shape

Rod ends can have different head shapes in accordance with the relevant standard requirements (**figure 7**).

See the rod end head shape of each series in the relevant product tables.

For specific rod end head shapes, other than the ones specified in the product tables, refer to *Customized products* **page 295** and contact SKF.

Rod end body features

Thread type

SKF provides external or internal threads on rod end bodies (**figure 8**).

Rod end bodies with external thread have a rolled external thread to be screwed into a threaded housing.

Rod end bodies with internal thread have an internal thread to be mounted on a threaded shaft.

Threads are defined in accordance with international standards. External threads are rolled.

SKF supplies right-hand or left-hand threads. See the relevant product tables.

Groove and keyway

A locating groove is a horizontal groove in the shank used to indicate the minimum insertion length for the rod end. This enables correct rod end positioning and ensures that the thread is fully supported and that the rod end can sustain its full loading capacity.

A keyway is a vertical groove that can be used for rod end orientation or as an anti-rotation slot for tab washers. See **figure 9**.

In presence of a locating groove, both the locating groove and keyway (if present) are painted in red.

Locating locking hole

A hole can be integrated into the rod ends with internal thread to:

- Ensure the locking of the rod end by inserting a pin and prevent unscrewing
- Check that the insertion length for the rod end is above the minimum limit. See **figure 10**

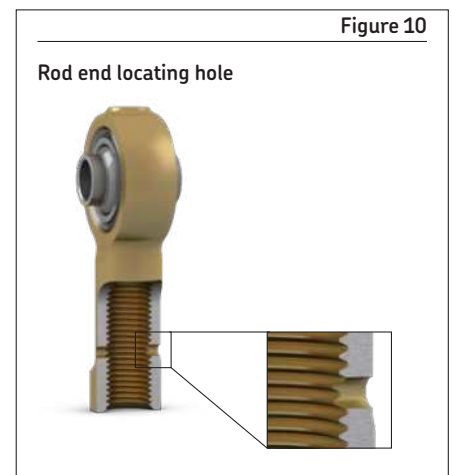
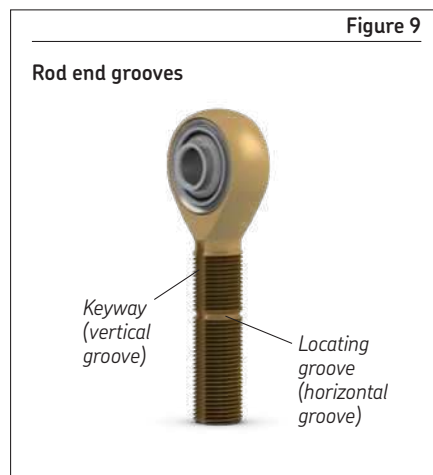
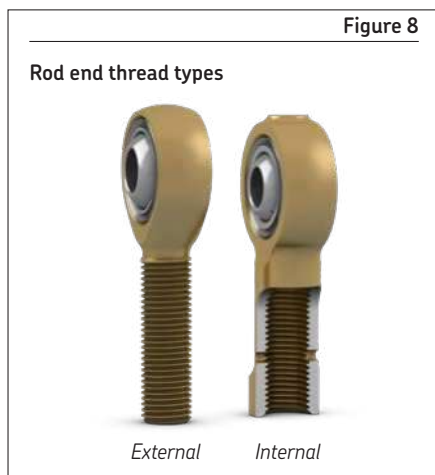
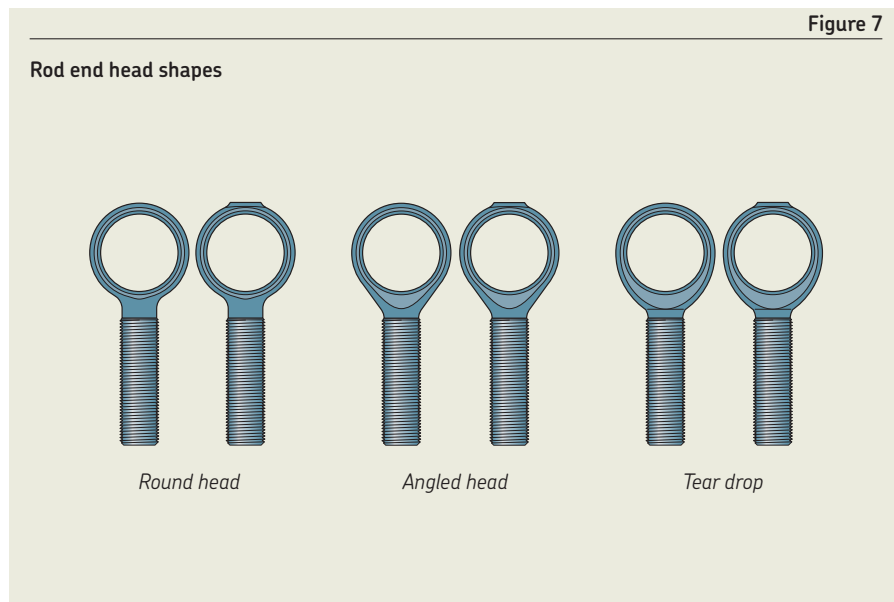

Bearing handling

Mounting

Rod ends are fitted on pins and shafts in the same way as the bearing type they use. Refer to the relevant *Mounting section* **page 49** for rolling bearings and **page 153** for spherical plain bearings.

When attaching rod ends to threaded rods or extension tubes (**figure 11**), it is important to ensure that the insertion length is sufficient. When rod ends have a locating groove, ensure to screw the rod end in until the groove is covered.

Use a counter locking nut or a tab washer to retain the rod end.

These should be used on the external thread (rod or rod end body) and should be securely tightened against the abutment surface on the rod end or tube.

Dismounting

Rod end dismounting

To dismount rod ends, loosen the lock nut securing the shank and, if possible, unscrew the rod end from its rod or tube. Then remove the rod end from the pin or shaft the same way as for a bearing. Refer to the relevant *Dismounting section* **page 50** for rolling bearings and **page 155** for spherical plain bearings.

Bearing dismounting from rod end

It is not recommended to remove the bearing from the rod end body. If the bearing becomes damaged, or reaches its wear limit, it is necessary to replace the rod end assembly.

Storage

The performance of rod ends, bearings, seals and lubricants can be impacted by the rod end and bearing storage conditions and time in inventory. SKF recommends a “first in, first out” inventory policy and that the rod ends and bearings are stored under the storage conditions and storage time specified below.

Storage conditions

To maintain the integrity of the product during storage, SKF recommends the following basic housekeeping practices:

- Store rod ends in a stable, clean, vibration-free, and dry area with a cool and steady temperature. See temperature limits in **table 8**
- Control and limit relative humidity of the storage area, see limits in **table 8**
- Keep rod ends in their original individual unopened packages until immediately prior to mounting in application in order to prevent risk of bearing deterioration such as corrosion or the ingress of contaminants.

Beyond the limit storage time for metal-to-metal spherical plain bearings and ball bearings, the ageing of grease and degradation of grease properties can lead to a reduction of bearing performance. Therefore, after five years of storage, the grease in the bearings must be replaced by SKF.

For storage outside these conditions, the stated storage life is not guaranteed. Contact SKF for more information.

3

Table 8

Storage life	Ball bearing rod end	Metal-to-metal rod end	Self-lubricating rod end
Storage life	5 years	5 years	15 years ¹⁾
Storage temperature	15 to 35 °C (59 to 95 °F)	15 to 35 °C (59 to 95 °F)	15 to 25 °C (59 to 77 °F)
Relative humidity	50 to 70%	50 to 70%	50 to 70%

¹⁾ Can be limited by specific combinations of surface treatment and marking technology. Always refer to the dates indicated on SKF's packaging. Contact SKF for more information

Figure 11

Securing a rod end with a right-hand thread

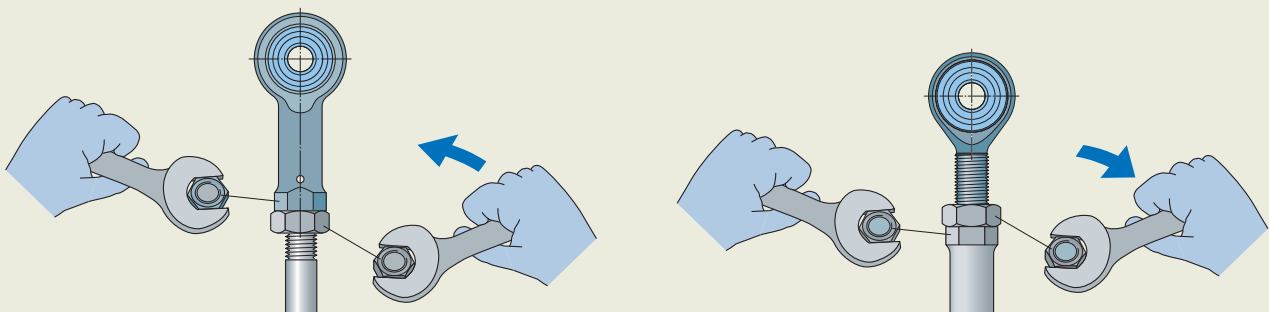

Customized products

SKF designs and manufactures customized rod ends to meet specific application requirements.

Examples can include, but are not limited to:

- **Specific geometries and dimensions**
- **Materials, including:**
 - Alternative steel alloys and corrosion-resistant steel
 - Titanium alloys
- **Surface treatments**, including chemical passivation, cadmium plating or zinc-nickel plating. Certain treatments include chromium 6 compounds and may be subject to environmental legislation
- **Lubricants** as specified in the rolling bearing and metal-to-metal spherical plain bearing sections or **liners** as specified in the spherical plain bearing section
- **Greasing solutions** as specified in the rolling bearing and metal-to-metal spherical plain bearing sections
- **Sealing solutions** as specified in the relevant product sections

Legacy products

The legacy series listed in **table 9** are delivered and marked according to the listed cross-reference designation system (see also the relevant product tables).

Legacy standards

SKF can supply bearings compliant to the following legacy standards :

- EN 4351

Function Typical SKF customized solutions

Rod end head and shank shapes



Including alternative head shapes (round, angled, tear drop ...), bump stops, locking features or angle between shank and head ...

Geometries and designs



Split metal-to-metal bearing inner ring rod ends

Double ended links

Inserted rolling bearing rod ends

3

Table 9

Cross-reference to legacy products

Variant	Cross-reference designation system	SKF Aerospace France designation system Lons-le-Saunier (formerly known as SARMA)	SKF Aerospace U.K. Limited designation system Clevedon (formerly known as AMPEP)
Wide inch external thread	MJ/WAS..	UMJ/XRL..	12BM..
Narrow inch external thread	MJ/NAS..	UMJ/XRE..	12BNM..
Wide inch external thread with PH13.8 body	PHMJ/WAS..	PHUMJ/XRL..	12CM..
Narrow inch external thread with PH13.8 body	PHMJ/NAS..	PHUMJ/XRE..	12CNM..
Wide inch internal thread	FJ/WAS..	UFJ/XRL..	12BF..
Narrow inch internal thread	FJ/NAS..	UFJ/XRE..	12BNF..
Wide inch internal thread with PH13.8 body	PHFJ/WAS..	PHUFJ/XRL..	12CF..
Narrow inch internal thread with PH13.8 body	PHFJ/NAS..	PHUFJ/XRE..	12CNF..

3.1 External thread rod end with integrated rolling bearing (metric dimensions)

C..MJ, CN..MJ

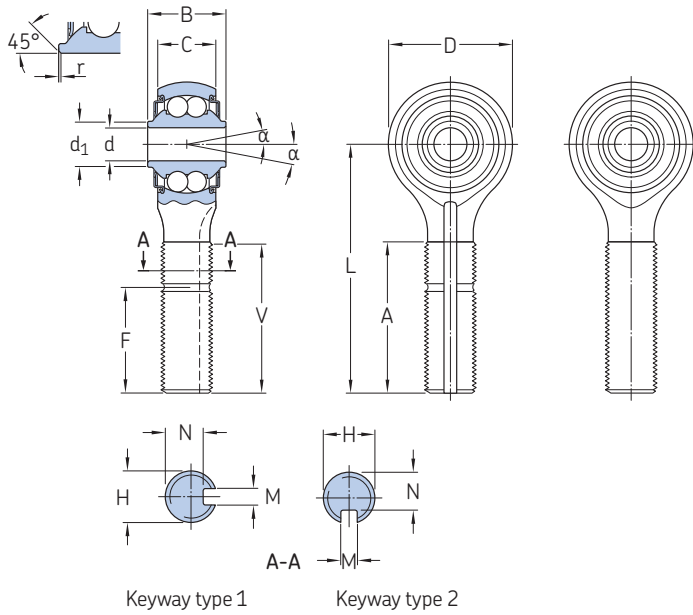

Technical specification	EN 2067
Product standard	EN 3541 (bearing in bearing steel)
	EN 4036 (bearing in corrosion-resistant steel)

3.1

Dimensions

Nominal bore code	Dimensions												
	d	D	B	C	A	V	d_1	H	L	F	M	N	
	0/-0,008	+0,2/0	0/-0,12	+0,1/0	Min	+0,5/0	≈	4h 6h	±0,5	Min	+0,1/0	0/-0,1	
	mm								mm				
5	5	20,5	12	8,5	33	33	7,6	MJ8 × 1	48	18	1,6	6,6	
N 6	6	22,5	14	10	37	37	8,6	MJ10 × 1,25	54	23	2,4	8,0	
N 8	8	28,5	15	10	42	42	11,1	MJ12 × 1,25	62	27	2,4	10,2	
N10	10	32	20	14	48	48	13,6	MJ14 × 1,5	73	31	3,2	12,2	

Dimensions cont., loads, torque and clearance

Nominal bore code	Dimensions		Mass	Limit static loads		Max. starting torque		Max. swiveling torque	Max. axial clearance	Radial clearance	
	r	α		Radial	Axial	Shielded	Sealed			EN 4036 (bearing in corrosion-resistant steel)	EN 3541 (bearing in bearing steel) Maximum
	+0,3/-0,2	°	g	C_s	C_a	mNm			μm		
5	0,5	8	35	4,7	1,5	1	2	150	80	1/5	20
N 6	0,5	8	60	6,8	2,11	2	4	150	80	1/5	20
N 8	0,5	8	85	8,9	2,8	5	10	200	80	1/5	20
N10	0,5	8	130	14	4,4	7	12	200	80	1/5	20

Designation system

Example: ZXCN 6MJEGRK N811
WC 5MJN741

Material and surface treatment

Inner ring and balls		Rod end body
No code	Bearing steel	Cadmium plated steel
S ¹⁾	Bearing steel	Zinc-nickel plated steel
W ¹⁾	Corrosion-resistant steel	Cadmium plated steel
SW ¹⁾	Corrosion-resistant steel	Zinc-nickel plated steel
X	Corrosion-resistant steel	Corrosion-resistant steel
ZX ¹⁾	Corrosion-resistant steel	Cadmium plated corrosion-resistant steel
SZX ¹⁾	Corrosion-resistant steel	Zinc-nickel plated corrosion-resistant steel

Basic designation

Bore code

Shield and seal

No code	Shielded
E	Sealed

Thread direction

No code	Right-hand thread
G	Left-hand thread

Locating groove

No code	Without locating groove ¹⁾
R	With locating groove

Keyway

No code	Without keyway
K	With keyway type 1
K2 ²⁾	With keyway type 2

Lubricant

N741	Grease G354
N811	Grease G395

¹⁾ SKF option

²⁾ SKF option for bearing in bearing steel



3.2 External thread rod end with integrated rolling bearing (metric dimensions)

C..M, CN..M, CN..M..SP1

Technical specification –
Product standard –

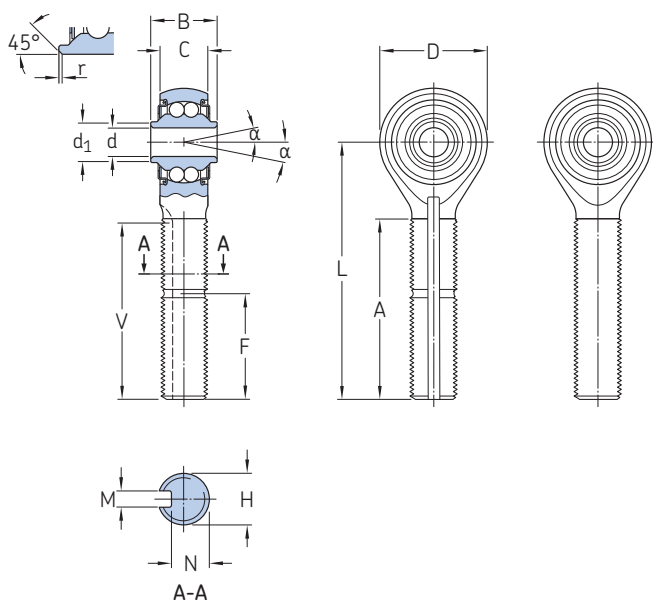

3.2



Dimensions

Nominal bore code	Dimensions		B	C	A	V	d ₁	H	L	F	M	N	
	d	D											
	0/-0,008	+0,2/0	0/-0,12	+0,1/0	Min	+0,5/0	≈	4h	±0,5	Min	+0,1/0	0/-0,1	
	mm								mm				
5	5	20,5	12	8,5	33	33	7,6	M8 × 1	48	18	1,6	6,6	
N 6	6	22,5	14	10	37	37	8,6	M10 × 1	54	22	2,4	8	
N 8	8	28,5	15	10	42	42	11,1	M12 × 1	62	25	2,4	10,2	
N 8..SP1	8	28,5	15	10	42	42	11,1	M12 × 1,5	62	25	2,4	10,2	
N10	10	32	20	14	48	48	13,6	M14 × 1,5	73	31	3,2	12,2	
N10..SP1	10	32	20	14	48	48	13,6	M14 × 1	73	31	3,2	12,2	

Dimensions cont, loads, torque and clearance

Nominal bore code	Dimensions		Mass	Static limit loads		Max. starting torque		Max. swivelling torque	Max. axial clearance
	r	α		Radial C _s	Axial C _a	Shielded	Sealed		
	+0,3/-0,2	°	g	kN		mNm		μm	
5	0,5	8	35	4,7	1,5	1	2	150	80
N 6	0,5	8	50	6,8	2,1	2	4	150	80
N 8	0,5	8	80	8,9	2,8	5	10	200	80
N 8..SP1	0,5	8	80	8,9	2,8	5	10	200	80
N10	0,5	8	130	14	4,4	7	12	200	80
N10..SP1	0,5	8	130	14	4,4	7	12	200	80

Designation system

Example: ZXCN 8MESP1GRKG81
C 5M

Material and surface treatment

Inner ring and balls		Rod end body
No code	Bearing steel	Cadmium plated steel
S	Bearing steel	Zinc-nickel plated steel
W	Corrosion-resistant steel	Cadmium plated steel
SW	Corrosion-resistant steel	Zinc-nickel plated steel
X	Corrosion-resistant steel	Corrosion-resistant steel
ZX	Corrosion-resistant steel	Cadmium plated corrosion-resistant steel
SZX	Corrosion-resistant steel	Zinc-nickel plated corrosion-resistant steel

Basic designation

Bore code

Shield and seal

No code	Shielded
E	Sealed

Thread direction

No code	Right-hand thread
G	Left-hand thread

Locating groove

No code	Without locating groove
R	With locating groove

Keyway

No code	Without keyway
K	With keyway

Lubricant

No code	Grease G354
G81	Grease G395

3.2



3.3 External thread integrated metal-to-metal spherical plain bearing rod end (metric dimensions)

EM..

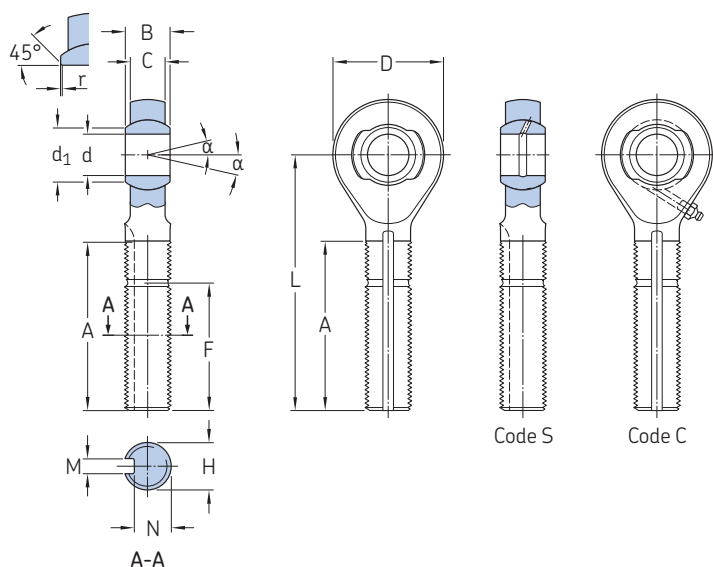

Technical specification	-
Product standard	-

3.3

Dimensions

Nominal bore code	Dimensions		D	B	C	A	V	H MJ 4h 6h	L	d ₁
	d	Tolerances Δdmp								
-	mm	μm	mm			Min	+0,5/0	-	mm	≈
12	12	0/-8	32	13	10	48	48	14 × 1,5	74	12,6
15	15	0/-8	40	15	12	56	56	16 × 1,5	85	15,6
17	17	0/-8	42	16	13,5	63	63	18 × 1,5	93	17,6
20	20	0/-9	51	22	18	78	78	22 × 1,5	115	20,6
25	25	0/-9	62	25	20	85	85	24 × 2	130	25,6
30	30	0/-9	70	28	24	93	93	27 × 2	145	30,6
35	35	0/-11	80	31	26	100	100	33 × 2	155	35,6
40	40	0/-11	88	34	29	125	125	36 × 2	190	40,6

Dimensions cont., loads and clearance

Nominal bore code	Dimensions		N	r	α	Mass ≈	Ultimate radial load ¹⁾	Axial clearance	
	F Min	M +0,1/0						EM	EMS/EMC
-	mm		0/-0,1	+0,3/0	°	g	kN	μm	
12	37	3,2	12,2	0,1	10	120	65	5/25	15/40
15	43	3,2	13,7	0,1	8	200	95	5/25	15/40
17	48	3,2	15,8	0,1	7	250	120	5/25	15/40
20	59	4	19,4	0,1	8	490	170	10/30	20/45
25	65	4	21,4	0,1	8	720	210	10/30	20/45
30	73	4,8	24,3	0,1	6	1 030	270	10/30	20/45
35	89	4,8	30	0,1	7	1 540	400	15/40	25/50
40	97	6,4	32,5	0,1	6	2 190	475	15/40	25/50

¹⁾ Loads are valid for rod end bodies made of alloy steel or corrosion resistant steel. For other rod ends, refer to page 292

Designation system

Examples: XEMS20G-2
EM12

X EM S 20 G -2

Material and surface treatment

	Inner ring	Rod end body
No code	Cadmium plated steel	Cadmium plated steel
S	Zinc-nickel plated steel	Zinc-nickel plated steel
W	Corrosion-resistant steel	Cadmium plated steel
SW	Corrosion-resistant steel	Zinc-nickel plated steel
X	Corrosion-resistant steel	Corrosion-resistant steel
Q	Bronze beryllium	Corrosion-resistant steel

Basic designation

Lubrication grooves

No code	Without lubrication groove
S	Lubrication by inner ring
C	Lubrication by rod end body

Bore code

Thread direction

No code	Right-hand thread
G	Left-hand thread

Lubricant

No code	Grease G354
-2	Grease G395

3.3



3.4 External thread inserted wide metal-to-metal spherical plain bearing rod end (metric dimensions)

EMJ/..ML

Technical specification	-
Product standard	-
Bearing	ML..R

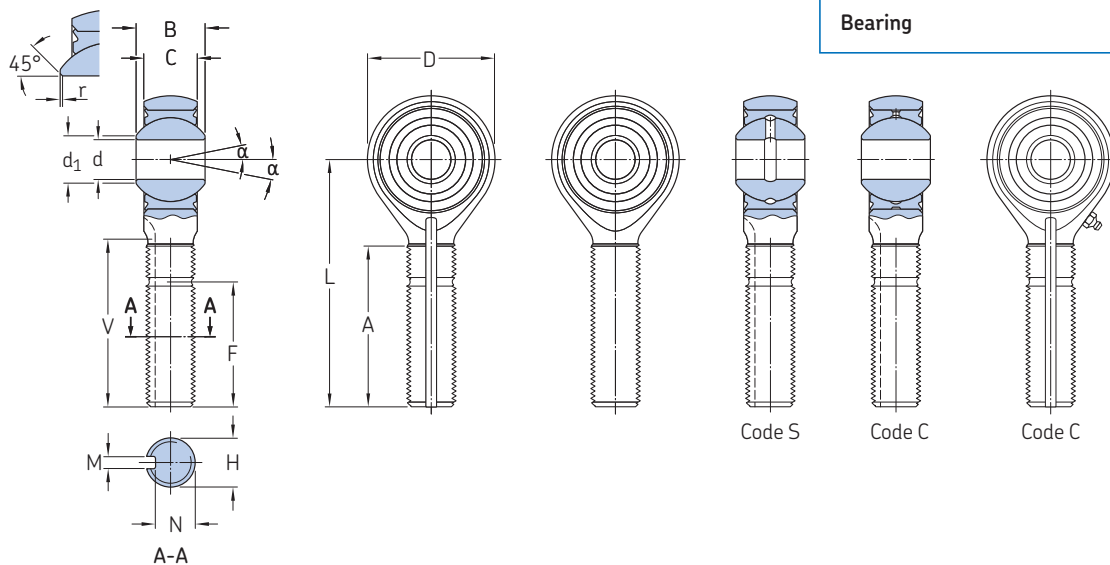

3.4

Dimensions

Nominal bore code	Dimensions		D	B	C	A	V	H MJ 4h 6h	L	d ₁	F
	d	Tolerances Δdmp									
-	mm	μm	mm	mm	mm	mm	mm	mm	mm	mm	mm
5	5	0/-8	21	11	8,7	28	28	8 × 1	46	7,7	18
6	6	0/-8	22,5	11	8,7	37	37	10 × 1,25	54	7,7	22
8	8	0/-8	26	11	8,2	42	42	12 × 1,25	62	10,3	25
10	10	0/-8	32	12,5	10,2	48	48	14 × 1,5	73	12,2	31
12	12	0/-8	37	16	13,2	56	56	16 × 1,5	85	15,5	34
15	15	0/-8	41,5	17	13,7	70	70	20 × 1,5	100	18,9	41
17	17	0/-8	43	18	14,7	78	78	22 × 1,5	107	20,1	46
20	20	0/-10	50	20	16,2	85	85	24 × 2	121	23,5	50
25	25	0/-10	77	32	26,2	100	100	33 × 2	154	35,3	65

Dimensions cont., loads and clearance

Nominal bore code	Dimensions		r	α	Mass ≈	Radial load Ultimate ¹⁾	Fatigue 10 ⁶ cycles	Axial clearance	
	M	N						Standard	Reduced
-	mm	mm	mm	°	g	kN	mm	mm	mm
5	1,6	6,6	0,1	15	40	30	5	17/75	35 max
6	2,4	8	0,1	15	55	40	7,1	17/75	35 max
8	2,4	10,2	0,1	14	75	50	8,6	17/75	35 max
10	3,2	12,2	0,1	10	125	90	14,8	17/75	35 max
12	3,2	13,7	0,1	10	195	110	18,7	17/75	35 max
15	4	17,4	0,1	9	285	130	22,3	17/75	35 max
17	4	19,4	0,1	9	340	150	24,8	20/80	40 max
20	4	21,4	0,1	8	490	190	31,6	20/80	40 max
25	4,8	30	0,1	9	1 590	475	78,4	25/100	50 max

¹⁾ Loads are valid for rod end bodies made of alloy steel or corrosion resistant steel. For other rod ends, refer to page 292



Designation system

Examples: XEMJ/WQMLS 6GRKX-2
EMJ/WML20

X EMJ/ WQ ML S 6 G R K X -2

Rod end body material

No code Cadmium plated steel
S Zinc-nickel plated steel
X Corrosion-resistant steel
T¹⁾ Anodized titanium

Basic designation

Bearing material

	Inner ring	Outer ring
W	Corrosion-resistant steel	Corrosion-resistant steel
Q	Bronze beryllium	Corrosion-resistant steel
WQ	Corrosion-resistant steel	Bronze aluminium

Lubrication grooves

No code Without lubrication groove
S Lubrication by inner ring
C Lubrication by rod end body

Bore code

Thread direction

No code Right-hand thread
G Left-hand thread

Locating groove

No code Without locating groove
R With locating groove

Keyway

No code Without keyway
K With keyway

Internal clearance

No code Standard clearance
X Reduced clearance

Lubricant

No code Grease G354
-2 Grease G395

¹⁾ SKF option, masses and load carrying capability reduced compared to steel rod end body.

3.5 External thread inserted high misalignment metal-to-metal spherical plain bearing rod end (metric dimensions)

EMJ../MT

Technical specification	–
Product standard	–
Bearing	MT..R

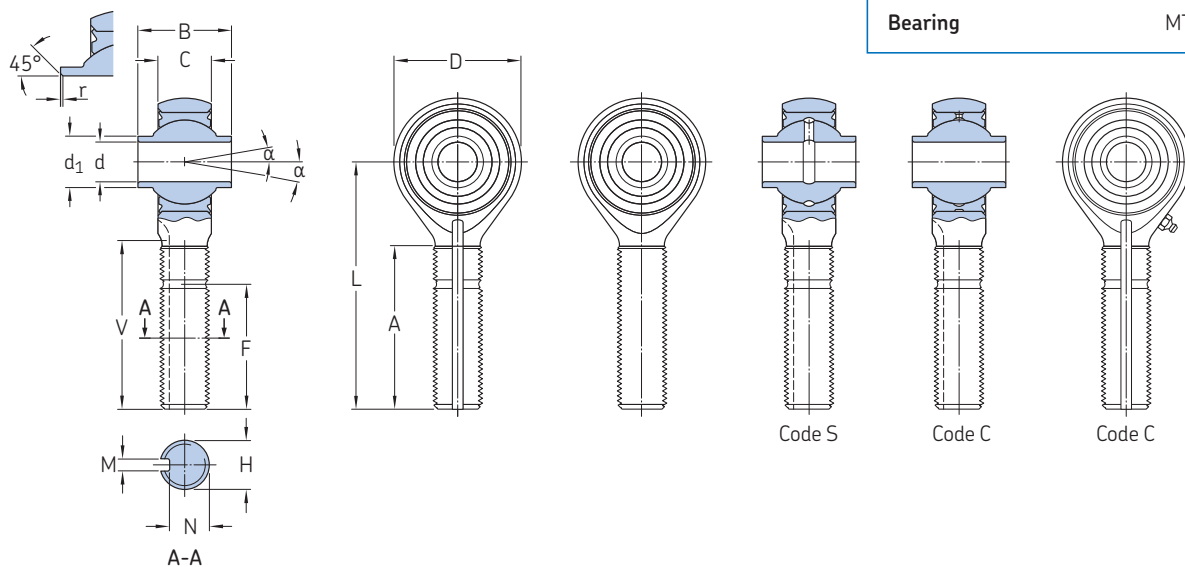

3.5

Dimensions

Nominal bore code	Dimensions		D	B	C	A	V	H MJ 4h 6h	L	d ₁	F Min
	d	Tolerances Δdmp									
–	mm	μm	mm	mm	mm	Min	+0,5/0	–	mm	≈	–
5	5	0/–8	19	12,5	5,2	28	28	8 × 1	45	7,8	18
6	6	0/–8	25	15	6,2	37	37	10 × 1,25	58	9,6	22
8	8	0/–8	35	21	9,2	42	42	12 × 1,25	71	13,3	25
10	10	0/–8	35	21,0	9,2	48	48	14 × 1,5	77	13,3	31
12	12	0/–8	42	24	10,2	56	56	16 × 1,5	89	17,7	34
17	17	0/–8	51	30	14,2	78	78	22 × 1,5	115	21,8	46
20	20	0/–10	58	33	16,2	85	85	24 × 2	128	24	50
22	22	0/–10	65	36	16,2	93	93	27 × 2	140	28,3	55
25	25	0/–10	77	48	21,2	100	100	33 × 2	154	32,2	65

Dimensions cont., loads and clearance

Nominal bore code	Dimensions		r	α	Mass ≈	Radial loads Ultimate ¹⁾	Fatigue 10 ⁶ cycles	Axial clearance	
	M	N						Standard	Reduced
–	mm	mm	mm	°	g	kN	–	μm	–
5	1,6	6,6	0,1	15	30	21,2	3,4	17/75	35 max
6	2,4	8	0,1	24	55	30,6	4,9	17/75	35 max
8	2,4	10,2	0,1	20	115	76	12	17/75	35 max
10	3,2	12,2	0,1	20	135	76	12,2	17/75	35 max
12	3,2	13,7	0,1	20	225	102,1	16,4	17/75	35 max
17	4	19,4	0,1	20	440	174,8	28,3	20/80	40 max
20	4	21,4	0,1	19	610	240,1	38,7	20/80	40 max
22	4,8	24,3	0,1	19	810	270,5	43,4	20/80	40 max
25	4,8	30	0,1	21	1 460	401,3	64,9	25/100	50 max

¹⁾ Loads are valid for rod end bodies made of alloy steel or corrosion resistant steel. For other rod ends, refer to page 292



Designation system

Examples: XEMJ/WQMTS 6GRKX-2 X EMJ/ WQ MT S 6 G R K X -2
 EMJ/WMT20

Rod end body material
No code Cadmium plated steel
S Zinc-nickel plated steel
X Corrosion-resistant steel
T¹⁾ Anodized titanium

Basic designation

Bearing material
W Inner ring Corrosion-resistant steel Outer ring Corrosion-resistant steel
Q Bronze beryllium Corrosion-resistant steel
WQ Corrosion-resistant steel Bronze aluminium

Lubrication grooves
No code Without lubrication groove
S Lubrication by inner ring
C Lubrication by rod end body

Bore code
Thread direction
No code Right-hand thread
G Left-hand thread

Locating groove
No code Without locating groove
R With locating groove

Keyway
No code Without keyway
K With keyway

Internal clearance
No code Standard clearance
X Reduced clearance

Lubricant
No code Grease G354
-2 Grease G395

¹⁾ SKF option, masses and load carrying capability reduced compared to steel rod end body.

3.6 Internal thread rod end with integrated metal-to-metal spherical plain bearing (metric dimensions)

EF

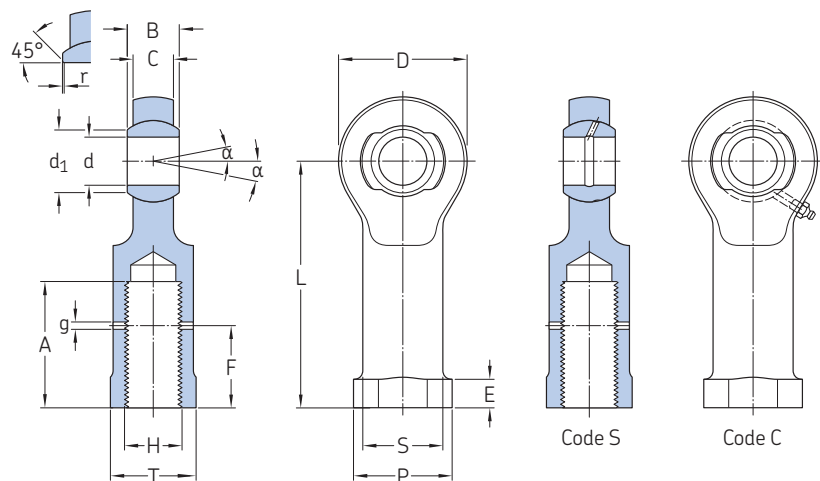

Technical specification -
Product standard -

3.6



Dimensions

Nominal bore code	Dimensions		D	B	C	A	H	L	P	d ₁	g
	d	Tolerances Δdmp									
-	mm	μm	mm			Min	MJ 4H 5H	mm		≈	≈
12	12	0/-8	32	13	10	31	14 × 1,5	60	24	12,6	1,8
15	15	0/-8	40	15	12	35	16 × 1,5	70	26	15,6	1,8
17	17	0/-8	42	16,0	13,5	40	18 × 1,5	76	31	17,6	1,8
20	20	0/-9	51	22	18	49	22 × 1,5	90	34	20,6	1,8
25	25	0/-9	62	25	20	53	24 × 2	105	37	25,6	1,8
30	30	0/-9	70	28	24	60	27 × 2	120	42	30,6	1,8
35	35	0/-11	80	31	26	66	33 × 2	140	53	35,6	1,8
40	40	0/-11	88	34	29	72	36 × 2	145	58	40,6	1,8

Dimensions cont., loads and clearance

Nominal bore code	Dimensions		T	E	r	α	Mass	Ultimate radial load	Axial clearance	
	F	S							EF	EFS/EFC
-	mm	mm				°	g	kN	μm	
12	20	19,5	21	7	0,1	10	120	65	5/25	15/40
15	24	22	23	7	0,1	8	190	95	5/25	15/40
17	26	24	27	8	0,1	7	240	120	5/25	15/40
20	33	29	30	8	0,1	8	430	170	10/30	20/45
25	36	32	33	8	0,1	8	680	210	10/30	20/45
30	40	36	37	8	0,1	6	990	270	10/30	20/45
35	50	44	46	9	0,1	7	1 570	400	15/40	25/50
40	54	48	50	9	0,1	6	1 940	475	15/40	25/50

Designation system

Examples: XEFS20G-2
EF12

X EF S 20 G -2

Material and surface treatment

Inner ring		Rod end body	
No code	Bearing steel	Cadmium plated steel	
S	Bearing steel	Zinc-nickel plated steel	
W	Corrosion-resistant steel	Cadmium plated steel	
SW	Corrosion-resistant steel	Zinc-nickel plated steel	
X	Corrosion-resistant steel	Corrosion-resistant steel	
Q	Bronze beryllium	Corrosion-resistant steel	

Basic designation

Lubrication grooves

No code	Without lubrication groove
S	Lubrication by inner ring
C	Lubrication by rod end body

Bore code

Thread direction

No code	Right-hand thread
G	Left-hand thread

Lubricant

No code	Grease G354
-2	Grease G395

3.6



3.7 Internal thread inserted wide metal-to-metal spherical plain bearing rod end (metric dimensions)

EFJ/..ML

Technical specification	–
Product standard	–
Bearing	ML..R

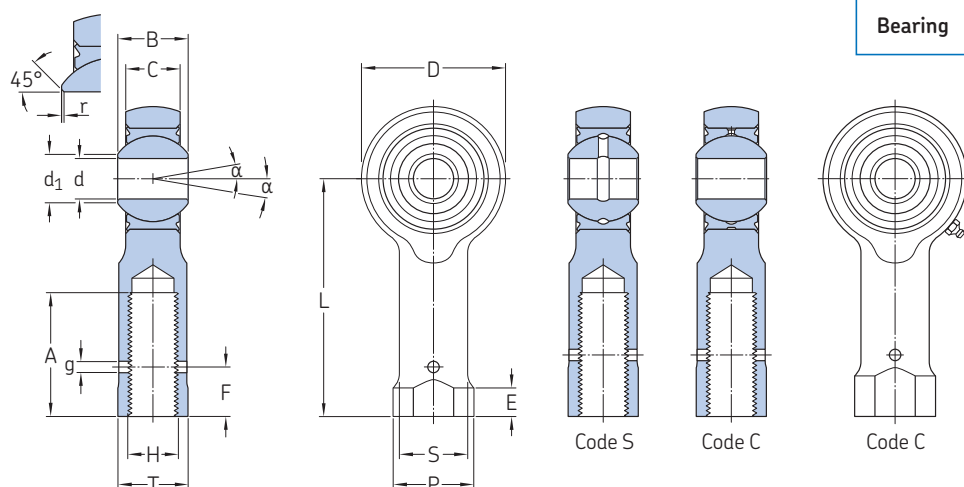

3.7

Dimensions

Nominal Dimensions

bore code	d	Tolerances Δd_{mp}	D +0,2/0	B 0/-0,06	C +0,1/0	A Min	H MJ 4H 5H	L $\pm 0,5$	P $\pm 0,2$	d_1 \approx	g \approx
5	5	0/-8	21	11	8,7	20	8 × 1	42	15	7,7	1,8
6	6	0/-8	22,5	11	8,7	25	10 × 1,25	48	17	7,7	1,8
8	8	0/-8	26	11	8,2	30	12 × 1,25	56	21	10,3	1,8
10	10	0/-8	32	12,5	10,2	31	14 × 1,5	62	24	12,2	1,8
12	12	0/-8	37	16	13,2	35	16 × 1,5	68	26	15,5	1,8
15	15	0/-8	41,5	17	13,7	44	20 × 1,5	82	31	18,9	1,8
17	17	0/-8	43	18	14,7	49	22 × 1,5	95	34	20,1	1,8
20	20	0/-10	50	20	16,2	53	24 × 2	100	37	23,5	1,8
25	25	0/-10	77	32	26,2	66	33 × 2	131	53	35,3	1,8

Dimensions cont., loads and clearance

Nominal bore code	Dimensions		T 0/-0,25	E \approx	r +0,3/0	α	Mass \approx	Radial loads Ultimate ¹⁾	Fatigue 10 ⁶ cycles	Axial clearance	
	F +0.5/0	S ± 0.1								Standard	Reduced
–	mm					°	g	kN		μm	
5	10	12	13	5	0,1	15	50	30	5	17/75	35 max
6	12	14	15	6	0,1	15	60	40	7,1	17/75	35 max
8	14	17	18	6	0,1	14	85	50	8,6	17/75	35 max
10	16	19,5	21	7	0,1	10	135	90	14,8	17/75	35 max
12	18	22	23	7	0,1	10	195	110	18,7	17/75	35 max
15	22	26	27	8	0,1	9	275	130	22,3	17/75	35 max
17	24	29	30	8	0,1	9	350	150	24,8	20/80	40 max
20	26	32	33	8	0,1	8	500	190	31,6	20/80	40 max
25	35	44	46	9	0,1	8	1 520	475	78,4	25/100	50 max

¹⁾ Loads are valid for rod end bodies made of alloy steel or corrosion resistant steel. For other rod ends, refer to page 292



Designation system

Examples: XEFJ/WQMLS 6GX-2 X EFJ/ WQ ML S 6 G X -2
 EFJ/WML20

Rod end body material
No code Cadmium plated steel
S Zinc-nickel plated steel
X Corrosion-resistant steel
T¹⁾ Anodized titanium

Basic designation

Bearing material
W Inner ring Corrosion-resistant steel Outer ring Corrosion-resistant steel
Q Bronze beryllium Corrosion-resistant steel
WQ Corrosion-resistant steel Bronze aluminium

Lubrication grooves
No code Without lubrication groove
S Lubrication by inner ring
C Lubrication by rod end body

Bore code

Thread direction
No code Right-hand thread
G Left-hand thread

Internal clearance
No code Standard clearance
X Reduced clearance

Lubricant
No code Grease G354
-2 Grease G395

¹⁾ SKF option, masses and load carrying capability reduced compared to steel rod end body.

3.8 Internal thread inserted high misalignment metal-to-metal spherical plain bearing rod end (metric dimensions)

EFJ/..MT

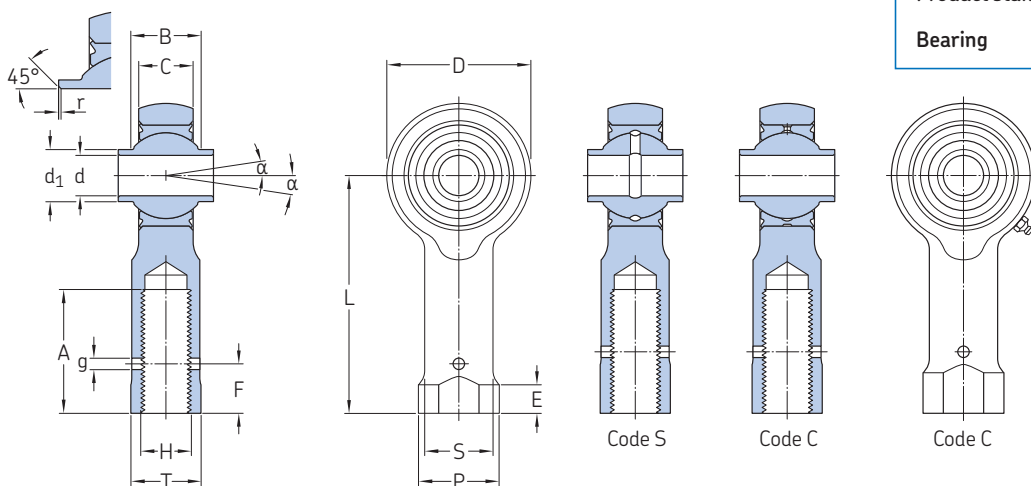

Technical specification	-
Product standard	-
Bearing	MT..R

3.8

Dimensions

Nominal Dimensions

bore code	d	Tolerances Δdmp	D	B	C	A	H MJ 4H 5H	L	P	d_1	F
	mm	μm	mm	mm	mm	mm	mm	mm	mm	mm	mm
-			+0,2/0	0/-0,06	+0,1/0	Min	-	$\pm 0,5$	$\pm 0,2$	\approx	+0.5/0
5	5	0/-8	19	12,5	5,2	20	8 x 1	41	15	7,8	10
6	6	0/-8	25	15	6,2	25	10 x 1,25	50	17	9,6	12
8	8	0/-8	35	21	9,2	30	12 x 1,25	60	21	13,3	14
10	10	0/-8	35	21,0	9,2	31	14 x 1,5	63	24	13,3	16
12	12	0/-8	42	24	10,2	35	16 x 1,5	72	26	17,7	18
17	17	0/-8	51	30	14,2	49	22 x 1,5	94	34	21,8	22
20	20	0/-10	58	33	16,2	53	24 x 2	104	37	24	26
22	22	0/-10	65	36	16,2	54	27 x 2	112	42	28,3	29
25	25	0/-10	77	48	21,2	66	33 x 2	133	53	32,2	35

Dimensions cont., loads and clearance

bore code	Nominal Dimensions		E	r	g	α	Mass	Radial loads	Fatigue	Axial clearance	
	S	T								Standard	Reduced
-	mm	mm	mm	mm	mm	°	g	kN	10 ⁶ cycles	μm	μm
5	12	13	5	0,1	1,8	15	35	21,2	3,4	17/75	35 max
6	14	15	6	0,1	1,8	24	60	30,6	4,9	17/75	35 max
8	17	18	6	0,1	1,8	20	125	76	12	17/75	35 max
10	19,5	21	7	0,1	1,8	20	140	76	12,2	17/75	35 max
12	22	23	7	0,1	1,8	20	220	102,1	16,4	17/75	35 max
17	29	30	8	0,1	1,8	20°	430	174,8	28,3	17/75	35 max
20	32	33	8	0,1	1,8	19	600	240,1	38,7	20/80	40 max
22	36	37	8	0,1	1,8	19	750	270,5	43,4	20/80	40 max
25	44	46	9	0,1	1,8	21	1 410	401,3	64,9	25/100	50 max

¹⁾ Loads are valid for rod end bodies made of alloy steel or corrosion resistant steel. For other rod ends, refer to page 292

Designation system

Examples: XEFJ/WQMTS 6GX-2
EFJ/WMT20

X EFJ/ WQ MT S 6 G X -2

Rod end body material

No code Cadmium plated steel
S Zinc-nickel plated steel
X Corrosion-resistant steel
T¹⁾ Anodized titanium

Basic designation

Bearing material

	Inner ring	Outer ring
W	Corrosion-resistant steel	Corrosion-resistant steel
Q	Bronze beryllium	Corrosion-resistant steel
WQ	Corrosion-resistant steel	Bronze aluminium

Lubrication grooves

No code Without lubrication groove
S Lubrication by inner ring
C Lubrication by rod end body

Bore code

Thread direction

No code Right-hand thread
G Left-hand thread

Internal clearance

No code Standard clearance
X Reduced clearance

Lubricant

No code Grease G354
-2 Grease G395

¹⁾ SKF option, masses and load carrying capability reduced compared to steel rod end body.



3.9 External thread inserted self-lubricating spherical plain bearing rod end (metric dimensions)

EMA..., EMA..SP1A..

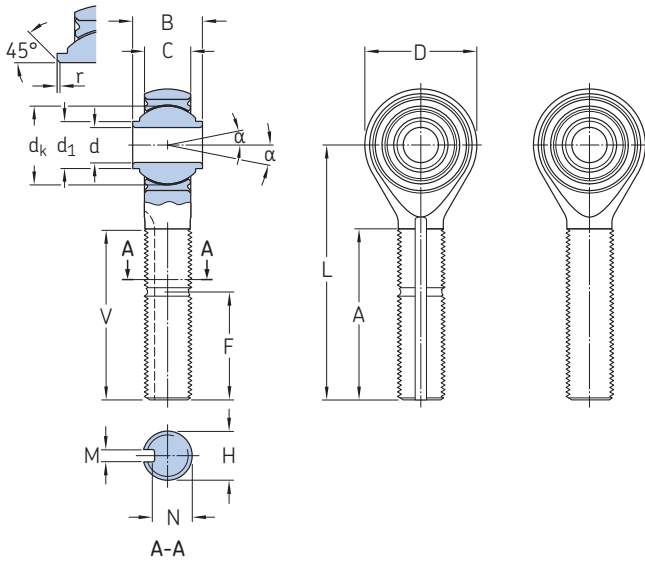

Technical specification	EN 2068
Product standard	EN 2498 (Cadmium plated steel 30NCD16 rod end) EN 4198 (Corrosion-resistant steel 17-4PH H1025 rod end)
Bearing	HMEN..R metric

3.9



Dimensions

Nominal bore code	Dimensions										
	d Δd_{mp} 0/-0,008	D +0,2/0	B 0/-0,06	C +0,1/0	A Min	V +0,5/-1	H ISO M thread ¹⁾ 4h 6h	ISO MJ thread (code J) 4h 6h	L $\pm 0,5$	d_k ≈	d_1 ≈
–	mm						–		mm		
6	6	22,5	14	8,2	37	37	M10 × 1	MJ10 × 1,25	54	15,0	9
8	8	26	15	10,2	42	42	–	MJ12 × 1,25	62	17,5	11
8SP1A¹⁾	8	26	15	10,2	42	42	M12 × 1,5	–	62	17,5	11
10²⁾	10	32	20	13,2	48	48	M14 × 1,5	MJ14 × 1,5	73	22,2	13,5

Dimensions cont., loads, torque and clearance

Nominal bore code	Dimensions					Mass ≈	Radial loads		Starting torque
	F Min	M +0,1/0	N 0/-0,1	r +0,3/-0,2	α		Ultimate ³⁾	Fatigue 10 ⁶ cycles	
–	mm					g	kN		Nm
6	23	2,4	8	0,5	9	46	27,0	4,5	0,45/1,3
8	27	2,4	10,2	0,5	8	76	39,0	6,0	0,7/2
8SP1A¹⁾	27	2,4	10,2	0,5	8	76	39,0	6,0	0,7/2
10²⁾	31	3,2	12,2	0,5	10	135	58,0	9,2	0,7/2

¹⁾ SKF option

²⁾ The radial dynamic load is limited by the rod end load carrying capability. The C25 value from RL..SP bearing is reduced to 38,6 kN.

³⁾ Loads are valid for rod end bodies made of alloy steel or corrosion resistant steel. For other rod ends, refer to page 292

Designation system

Example: XEMAJ 6GRK
TEMA 8SP1A

X EMA J 6 G R K

Rod end body material and surface treatment

No code Cadmium plated steel
S¹⁾ Zinc-nickel plated steel
X Corrosion resistant steel
T²⁾ Anodized titanium

Basic designation

Thread profile

No code¹⁾ ISO M Profile thread
J ISO MJ Profile thread

Bore code

Thread direction

No code Right-hand thread
G Left-hand thread

Locating groove

No code Without locating groove
R With locating groove

Keyway

No code Without keyway
K With keyway

1) SKF option

2) SKF option, masses and load carrying capability reduced compared to steel rod end body.



3.9

3.10 External thread inserted wide self-lubricating spherical plain bearing rod end (metric dimensions)

EMJ/RL..

Technical specification	EN 2755 for the bearing
Product standard	–
Bearing	WEN ..R metric

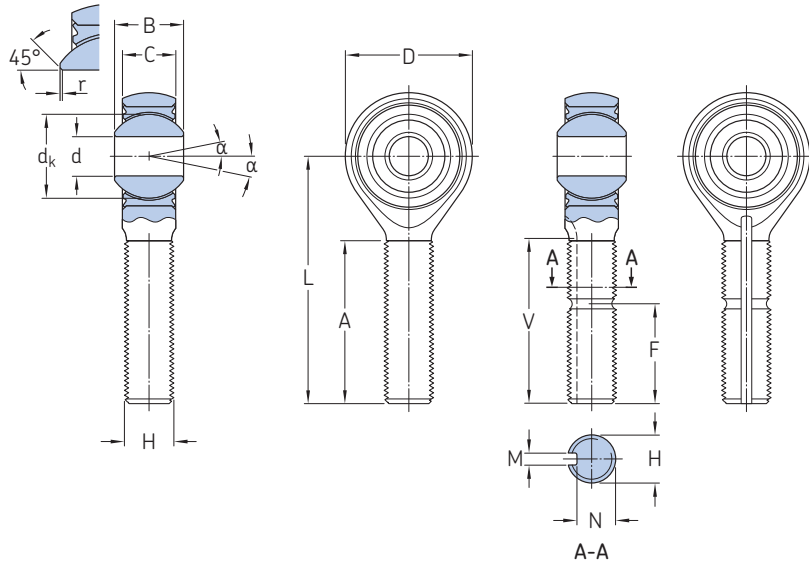

Dimensions

Nominal bore code	Dimensions d	Tolerances Δ mp	D	B	C	A	V	H MJ 4h 6h	L	d_k
–	mm	μm	mm						mm	
5	5	0/-8	21	11	8,7	28	28	8 × 1	46	13,4
6	6	0/-8	22,5	11	8,7	37	37	10 × 1,25	54	13,4
8	8	0/-8	26	11	8,2	42	42	12 × 1,25	62	15,1
10	10	0/-8	32	12,5	10,2	48	48	14 × 1,5	73	17,5
12	12	0/-8	37	16	13,2	56	56	16 × 1,5	85	22,3
15	15	0/-8	41,5	17	13,7	70	70	20 × 1,5	100	25,4
17	17	0/-8	43	18	14,7	78	78	22 × 1,5	107	27,0
20	20	0/-10	50	20	16,2	85	85	24 × 2	121	30,9
25	25	0/-10	77	32	26,2	100	100	33 × 2	154	47,6

Dimensions cont, loads and torque

Nominal bore code	Dimensions		N	r	α	Mass \approx	Radial loads		Starting torque	
	F Min	M $+0,1/0$					Ultimate ¹⁾	Fatigue 10^6 cycles	Standard	Reduced
–	mm		$0/-0,1$	$+0,3/0$	$^\circ$	g	kN		Nm	
5	18	1,6	6,6	0,1	15	40	30	5	0,08/1	0,005/0,12
6	22	2,4	8	0,1	15	55	40	7,1	0,08/1	0,005/0,12
8	25	2,4	10,2	0,1	14	75	50	8,6	0,12/1,6	0,006/0,16
10	31	3,2	12,2	0,1	10	125	90	14,8	0,12/1,6	0,008/0,2
12	34	3,2	13,7	0,1	10	195	110	18,7	0,12/1,6	0,008/0,2
15	41	4	17,4	0,1	9	285	130	22,3	0,12/1,6	0,01/0,24
17	46	4	19,4	0,1	9	340	150	24,8	0,12/1,6	0,01/0,24
20	50	4	21,4	0,1	8	490	190	31,6	0,12/1,6	0,01/0,24
25	65	4,8	30	0,1	9	1 590	475	78,4	0,25/2	0,015/0,5

¹⁾ Loads are valid for rod end bodies made of alloy steel or corrosion resistant steel. For other rod ends, refer to page 292

Designation system

Example:	XEMJ/RL 6GRKX EMJ/RL12	X	EMJ/RL	6	G	R	K	X
Rod end body material		_____						
No code	Cadmium plated 30NCD16 steel							
S	Zinc-nickel plated 30NCD16 steel							
X	Corrosion resistant steel 17-4PH H1025							
T¹⁾	Anodized titanium							
Basic designation		_____						
Bore code		_____						
Thread direction		_____						
No code	Right-hand thread							
G	Left-hand thread							
Locating groove		_____						
No code	Without locating groove							
R	With locating groove							
Keyway		_____						
No code	Without keyway							
K	With keyway							
Starting torque		_____						
No code	Standard							
X	Reduced							

1) SKF option, masses and load carrying capability reduced compared to steel rod end body.



3.11 External thread inserted high-misalignment self-lubricating spherical plain bearing rod end (metric dimensions)

EMJ/RT..

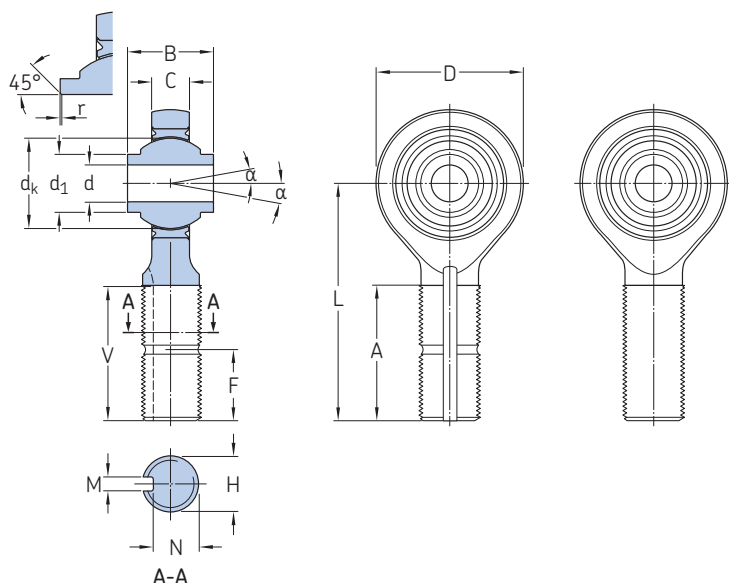

Technical specification	–
Product standard	–
Bearing	XRT..R metric

3.11



Dimensions

Nominal bore code	Dimensions d	Tolerances Δdmp	D	B	C	A	V	H MJ	L	dk	d1
			+0,2/0	0/-0,06	+0,1/0	Min	+0,5/0	4h 6h	±0,5	≈	≈
–	mm	μm	mm						mm		
5	5	0/-8	19	12,5	5,2	28	28	8 × 1	45	11,1	7,8
6	6	0/-8	25	15	6,2	37	37	10 × 1,25	58	15,1	9,6
8	8	0/-8	35	21	9,2	42	42	12 × 1,25	71	19,8	13,3
10	10	0/-8	35	21	9,2	48	48	14 × 1,5	77	19,8	13,3
12	12	0/-8	42	24	10,2	56	56	16 × 1,5	89	25,0	17,7
17	17	0/-8	51	30	14,2	78	78	22 × 1,5	115	31,5	21,8
20	20	0/-10	58	33	16,2	85	85	24 × 2	128	34,0	24,0
22	22	0/-10	65	36	16,2	93	93	27 × 2	140	38,9	28,3
25	25	0/-10	77	48	21,2	100	100	33 × 2	154	47,6	32,2

Dimensions cont, loads and torque

Nominal bore code	Dimensions		N	r	α	Mass ≈	Radial loads		Starting torque	
	F Min	M +0,1/0					Ultimate ¹⁾	Fatigue 10 ⁶ cycles	Standard	Reduced
–	mm		0/-0,1	+0,3/0	°	g	kN		Nm	
5	18	1,6	6,6	0,1	15	30	21,2	3,4	0,06/0,6	0,005/0,12
6	22	2,4	8	0,1	24	55	30,6	4,9	0,06/0,6	0,005/0,12
8	25	2,4	10,2	0,1	20	115	76	12	0,08/0,8	0,005/0,12
10	31	3,2	12,2	0,1	20	135	76	12,2	0,1/1	0,008/0,2
12	34	3,2	13,7	0,1	20	225	102,1	16,4	0,1/1	0,008/0,2
17	46	4	19,4	0,1	20	440	174,8	28,3	0,12/1,4	0,008/0,2
20	50	4	21,4	0,1	19	610	240,1	38,7	0,12/1,4	0,008/0,2
22	55	4,8	24,3	0,1	19	810	270,5	43,4	0,25/2	0,015/0,5
25	65	4,8	30	0,1	21	1 460	401,3	64,9	0,25/2	0,015/0,5

¹⁾ Loads are valid for rod end bodies made of alloy steel or corrosion resistant steel. For other rod ends, refer to page 292

Designation system

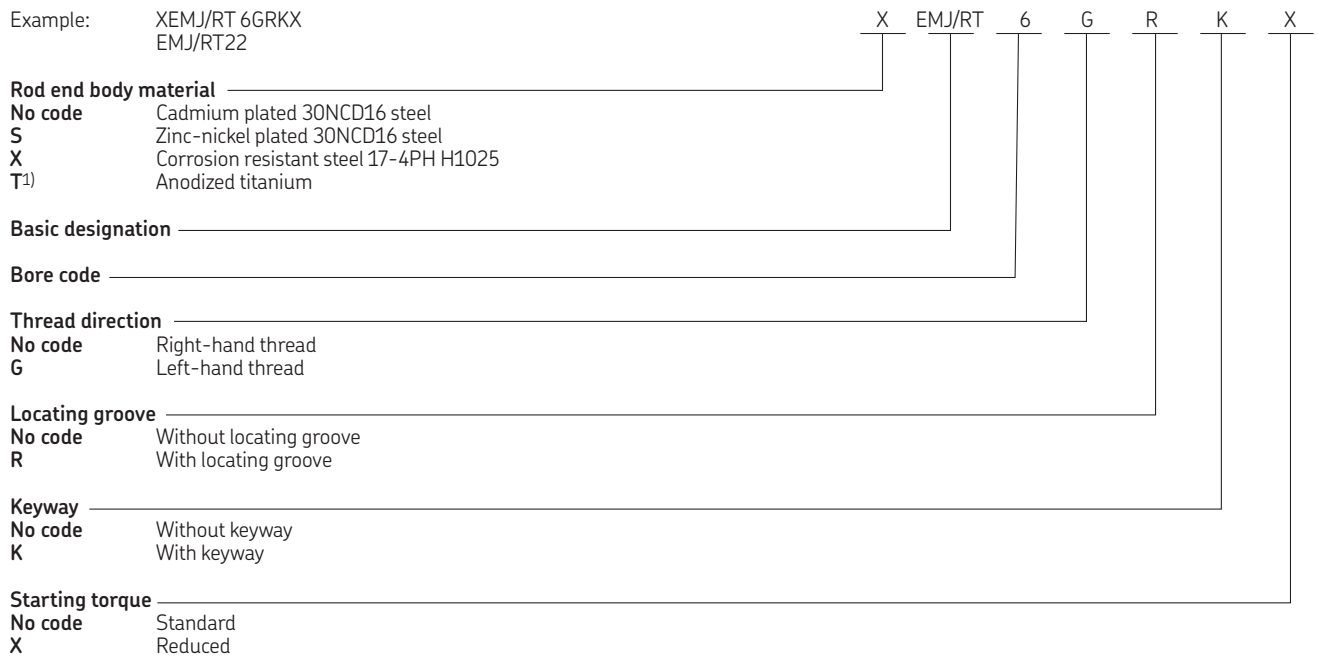

1) SKF option, masses and load carrying capability reduced compared to steel rod end body.



3.12 Internal thread inserted wide self-lubricating spherical plain bearing rod end (metric dimensions)

EFJ/RL..

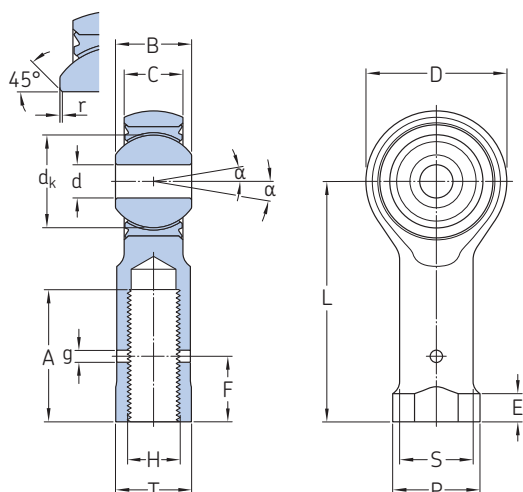

Technical specification	EN 2755 for the bearing
Product standard	–
Bearing	WEN..R metric

3.12



Dimensions

Nominal bore code	Dimensions		D	B	C	A	H	L	P	dk
	d	Tolerances Δdmp								
–	mm	μm	+0,2/0	0/–0,06	+0,1/0	Min	MJ 4H 5H	±0,5	±0,2	≈
5	5	0/–8	21	11	8,7	20	8 × 1	42	15	13,4
6	6	0/–8	22,5	11	8,7	25	10 × 1,25	48	17	13,4
8	8	0/–8	26	11	8,2	30	12 × 1,25	56	21	15,1
10	10	0/–8	32	12,5	10,2	31	14 × 1,5	62	24	17,5
12	12	0/–8	37	16	13,2	35	16 × 1,5	68	26	22,3
15	15	0/–8	41,5	17	13,7	44	20 × 1,5	82	31	25,4
17	17	0/–8	43	18	14,7	49	22 × 1,5	95	34	27,0
20	20	0/–10	50	20	16,2	53	24 × 2	100	37	30,9
25	25	0/–10	77	32	26,2	66	33 × 2	131	53	47,6

Dimensions cont, loads and torque

Nominal bore code	Dimensions			E	r	g	α	Mass ≈	Radial loads		Starting torque	
	F	S	T						Ultimate ¹⁾	Fatigue 10 ⁶ cycles	Standard	Reduced
–	mm	mm	mm	mm	mm	mm	°	g	kN		Nm	
5	10	12	13	5	0,1	1,8	15	50	30	5	0,08/1	0,005/0,12
6	12	14	15	6	0,1	1,8	15	60	40	7,1	0,08/1	0,005/0,12
8	14	17	18	6	0,1	1,8	14	85	50	8,6	0,12/1,6	0,006/0,16
10	16	19,5	21	7	0,1	1,8	10	135	90	14,8	0,12/1,6	0,008/0,2
12	18	22	23	7	0,1	1,8	10	195	110	18,7	0,12/1,6	0,008/0,2
15	22	26	27	8	0,1	1,8	9	275	130	22,3	0,12/1,6	0,01/0,24
17	24	29	30	8	0,1	1,8	9	350	150	24,8	0,12/1,6	0,01/0,24
20	26	32	33	8	0,1	1,8	8	500	190	31,6	0,12/1,6	0,01/0,24
25	35	44	46	9	0,1	1,8	8	1 520	475	78,4	0,25/2	0,015/0,5

¹⁾ Loads are valid for rod end bodies made of alloy steel or corrosion resistant steel. For other rod ends, refer to page 292

Designation system

Example: XEFJ/RL 6GX
EFJ/RL25

X EFJ/RL 6 G X

Rod end body material and surface treatment

No code Cadmium plated 30NCD16 steel
S Zinc-nickel plated 30NCD16 steel
X Corrosion resistant steel 17-4PH H1025
T¹⁾ Anodized titanium

Basic designation

Bore code

Thread direction

No code Right-hand thread
G Left-hand thread

Starting torque

No code Standard
X Reduced

¹⁾ SKF option, masses and load carrying capability reduced compared to steel rod end body.



3.13 Internal thread inserted high misalignment self-lubricating spherical plain bearing rod end (metric dimensions)

EFJ/RT..

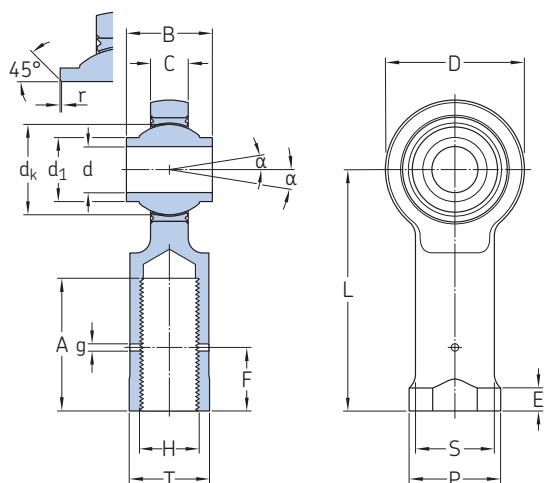

Technical specification	-
Product standard	-
Bearing	XRT..R

3.13



Dimensions

Nominal Dimensions

bore code	d	Tolerances Δd_{mp}	D	B	C	A	H MJ 4H 5H	L	P	d_k	d_1	g	F +0.5/0
-	mm	μm	mm			Min	-	mm		\approx	\approx	\approx	
5	5	0/-8	19	12,5	5,2	20	8 × 1	41	15	11,1	7,8	1,8	10
6	6	0/-8	25	15	6,2	25	10 × 1,25	50	17	15,1	9,6	1,8	12
8	8	0/-8	35	21	9,2	30	12 × 1,25	60	21	19,8	13,3	1,8	14
10	10	0/-8	35	21	9,2	31	14 × 1,5	63	24	19,8	13,3	1,8	16
12	12	0/-8	42	24	10,2	35	16 × 1,5	72	26	25,0	17,7	1,8	18
17	17	0/-8	51	30	14,2	49	22 × 1,5	94	34	31,5	21,8	1,8	22
20	20	0/-10	58	33	16,2	53	24 × 2	104	37	34,0	24,0	1,8	26
22	22	0/-10	65	36	16,2	54	27 × 2	112	42	38,9	28,3	1,8	29
25	25	0/-10	77	48	21,2	66	33 × 2	133	53	47,6	32,2	1,8	35

Dimensions cont., loads and torque

Nominal bore code	Dimensions			r +0,3/0	α	Mass \approx	Radial loads Ultimate ¹⁾	Fatigue 10 ⁶ cycles	Starting torque	
	S ± 0.1	T 0/-0.25	E \approx						Standard	Reduced
-	mm				$^\circ$	g	kN		Nm	
5	12	13	5	0,1	15	35	21,2	3,4	0,06/0,6	0,005/0,12
6	14	15	6	0,1	24	60	30,6	4,9	0,06/0,6	0,005/0,12
8	17	18	6	0,1	20	125	76	12	0,08/0,8	0,005/0,12
10	19,5	21	7	0,1	20	140	76	12,2	0,1/1	0,0008/0,2
12	22	23	7	0,1	20	220	102,1	16,4	0,1/1	0,0008/0,2
17	29	30	8	0,1	20	430	174,8	28,3	0,12/1,4	0,0008/0,2
20	32	33	8	0,1	19	600	240,1	38,7	0,12/1,4	0,0008/0,2
22	36	37	8	0,1	19	750	270,5	43,4	0,25/2	0,015/0,5
25	44	46	9	0,1	21	1 410	401,3	64,9	0,25/2	0,015/0,5

¹⁾ Loads are valid for rod end bodies made of alloy steel or corrosion resistant steel. For other rod ends, refer to page 292

Designation system

Examples: XEFJ/RT 6GX
EFJ/RT22

Rod end body material

No code Cadmium plated 30NCD16 steel
S Zinc-nickel plated 30NCD16 steel
X Corrosion-resistant steel 17-4PH H1025
T¹⁾ Anodized titanium

Basic designation

Bore code

Thread direction

No code Right-hand thread
G Left-hand thread

Starting torque

No code Standard
X Reduced

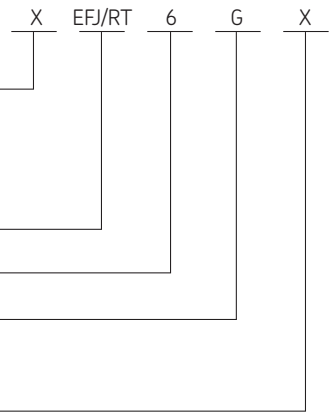

¹⁾ SKF option, masses and load carrying capability reduced compared to steel rod end body.



3.14 External thread rod end with integrated rolling bearing (inch dimensions)

CN..SP bore code **6,35..SP24** to **7,94..SP4** and **6,35..SP18** to **7,94..SP11**

Technical specification	-
Product standard	-
Grease	G354

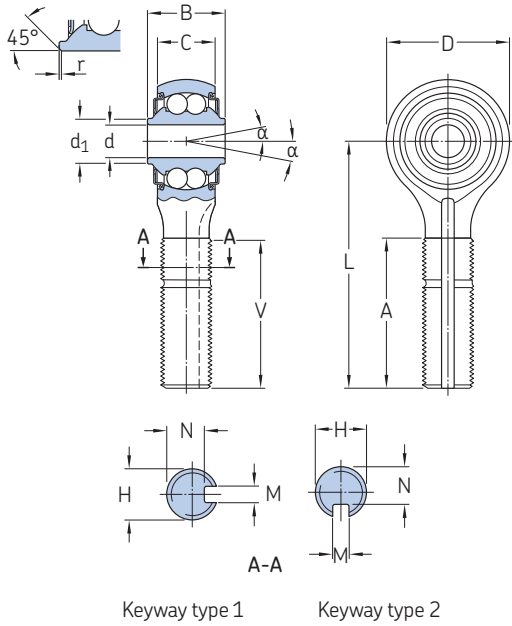

3.14

Dimensions

Nominal bore code	Keyway type	Dimensions										
		d	D	B	C	A	V	d ₁	H	L	M	
		0/-0.0005	±0.010	0/-0.005	±0.005	≈	+0.02/0	≈	3A	≈	+0.005/0	
		0/-0.13	±0.254	0/-0.127	±0.127		+0.5/0				+0.127/0	
-		in/mm							-	mm		
6,35..SP24¹⁾	6,35..SP18²⁾	1	0.2500	0.886	0.551	0.394	1.063	1.063	0.335	1/4-28	2.126	0.063
			6,350	22,5	14	10	27	27	8,500	6,35-28	54	1,6
6,35..SP6¹⁾	6,35..SP23²⁾	1	0.2500	0.886	0.551	0.394	1.457	1.457	0.335	5/16-24	2.126	0.063
			6,350	22,5	14	10	37	37	8,500	7,94-24	54	1,6
6,35..SP2¹⁾	6,35..SP8²⁾	2	0.2500	0.886	0.551	0.394	1.457	1.457	0.335	3/8-24	2.126	0.095
			6,350	22,5	14	10	37	37	8,500	9,52-24	54	2,4
6,35..SP19¹⁾	6,35..SP19²⁾	1	0.2500	0.886	0.551	0.394	1.654	1.654	0.335	7/16-20	2.362	0.095
			6,350	22,5	14	10	42	42	8,500	11,11-20	60	2,4
6,35..SP20¹⁾	6,35..SP20²⁾	1	0.2500	0.886	0.551	0.394	2.047	2.047	0.335	1/2-20	3.051	0.095
			6,350	22,5	14	10	52	52	8,500	12,7-20	77,5	2,4
6,35..SP21¹⁾	6,35..SP21²⁾	1	0.2500	0.886	0.551	0.394	2.323	2.323	0.335	9/16-18	3.346	0.126
			6,350	22,5	14	10	59	59	8,500	14,29-18	85	3,2
6,35..SP22¹⁾	6,35..SP22²⁾	1	0.2500	0.886	0.551	0.394	2.480	2.480	0.335	5/8-18	3.150	0.126
			6,350	22,5	14	10	63	63	8,500	15,87-18	80	3
7,94..SP7¹⁾	7,94..SP7²⁾	1	0.3125	1.122	0.591	0.394	1.457	1.457	0.449	5/16-24	2.362	0.063
			7,938	28,5	15	10	37	37	11,400	7,94-24	60	1,6
7,94..SP4¹⁾	7,94..SP11²⁾	1	0.3125	1.122	0.591	0.394	1.457	1.457	0.449	3/8-24	2.362	0.095
			7,938	28,5	15	10	37	37	11,400	9,52-24	60	2,4

¹⁾ For bearing steel bearing and cadmium plated steel rod end body (No code), or for bearing steel bearing and zinc-nickel plated steel rod end body (Code S)

²⁾ For other materials/surface treatments (codes W, SW, X, ZX and SZX)

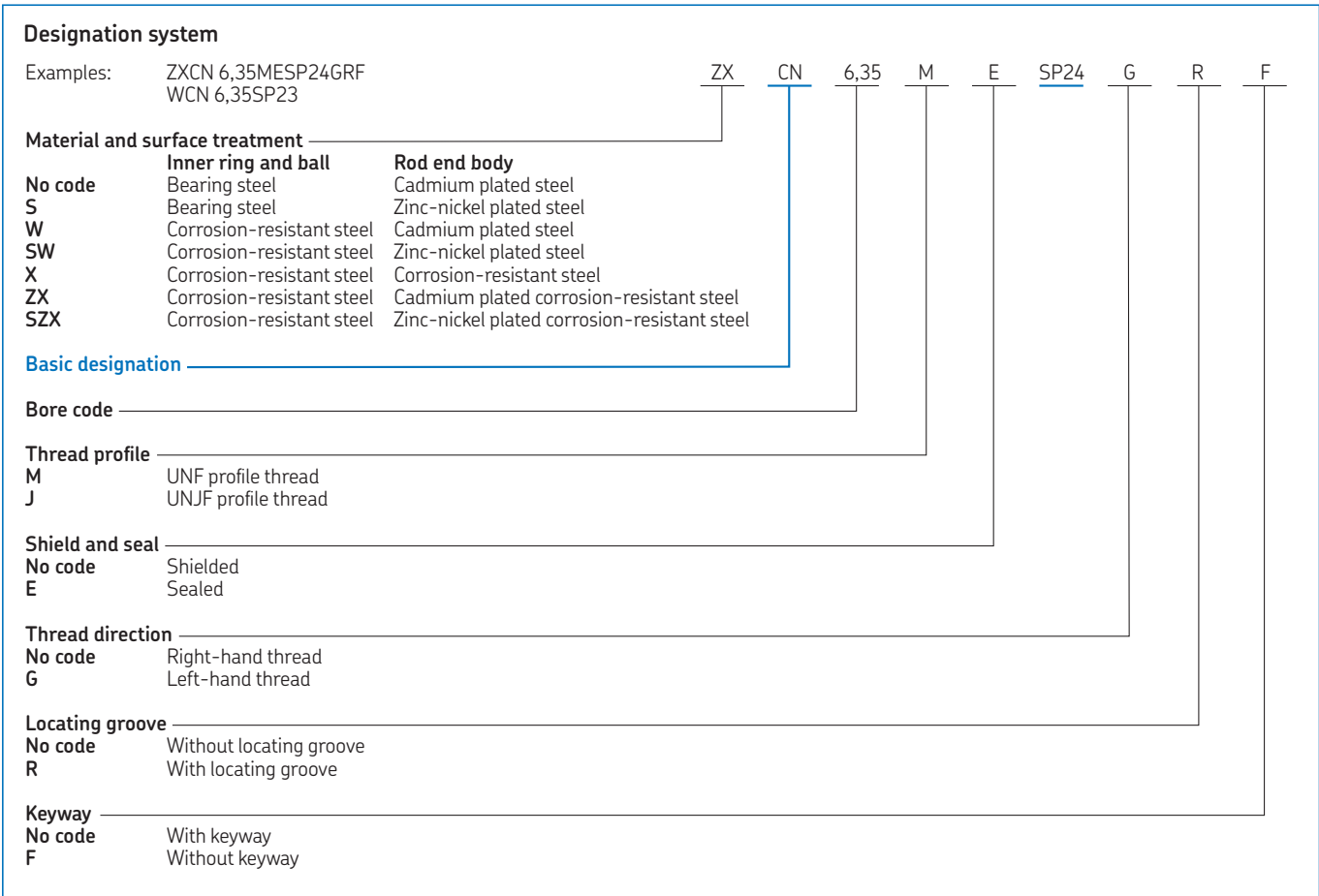

Dimensions cont. loads, torque and clearance

Nominal bore code	Keyway type	Dimensions			Mass ≈	Limit static loads		Axial clearance Max	Swivelling torque Max
		N	r	α		Radial C _s	Axial C _a		
		+0.005/0 +0.127/0	+0.014/0 +0.35/0						
–		in/mm		°	lb/g	lbf/kN		in/mm	oz.in/mN.
6,35..SP24 ¹⁾ 6,35..SP18 ²⁾	1	0,202 5,11	0,006 0,15	8	0,08 37	1 529 6,8	472 2,1	0,003 0,080	21.242 150
6,35..SP6 ¹⁾ 6,35..SP23 ²⁾	1	0,260 6,6	0,006 0,15	8	0,09 41	1 529 6,8	472 2,1	0,003 0,080	21.242 150
6,35..SP2 ¹⁾ 6,35..SP8 ²⁾	2	0,311 7,9	0,006 0,15	8	0,10 46	1 529 6,8	472 2,1	0,003 0,080	21.242 150
6,35..SP19 ¹⁾ 6,35..SP19 ²⁾	1	0,370 9,4	0,006 0,15	8	0,12 56	1 529 6,8	472 2,1	0,003 0,080	21.242 150
6,35..SP20 ¹⁾ 6,35..SP20 ²⁾	1	0,436 11,07	0,006 0,15	8	0,16 73	1 529 6,8	472 2,1	0,003 0,080	21.242 150
6,35..SP21 ¹⁾ 6,35..SP21 ²⁾	1	0,478 12,14	0,006 0,15	8	0,17 77	1 529 6,8	472 2,1	0,003 0,080	21.242 150
6,35..SP22 ¹⁾ 6,35..SP22 ²⁾	1	0,539 13,7	0,006 0,15	8	0,22 98	1 529 6,8	472 2,1	0,003 0,080	21.242 150
7,94..SP7 ¹⁾ 7,94..SP7 ²⁾	1	0,260 6,6	0,006 0,15	8	0,13 60	2 424 10,8	764 3,4	0,003 0,080	28.322 200
7,94..SP4 ¹⁾ 7,94..SP11 ²⁾	1	0,311 7,9	0,006 0,15	8	0,14 64	2 424 10,8	764 3,4	0,003 0,080	28.322 200

3.14 External thread rod end with integrated rolling bearing (inch dimensions)

CN..SP bore code 7,94..SP5 to 9,52..SP7 and 7,94..SP2 to 9,52..SP7

Technical specification	-
Product standard	-
Grease	G354

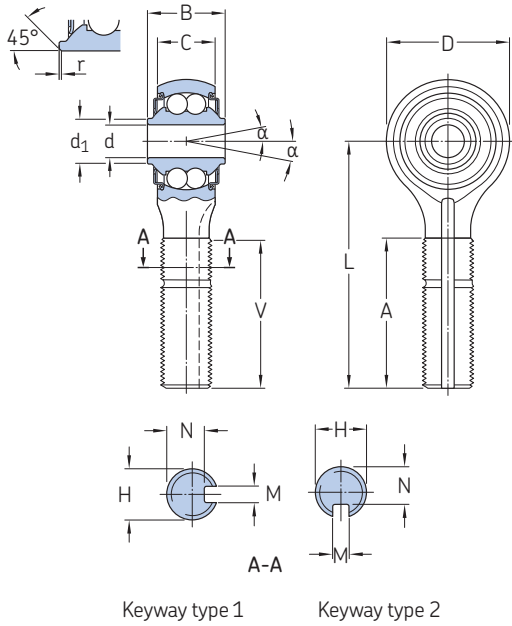

3.14

Dimensions

Nominal bore code	Keyway type	Dimensions										
		d 0/-0.0005 0/-0,13	D ±0.010 ±0,254	B 0/-0.005 0/-0,127	C ±0.005 ±0,127	A ≈	V +0.02/0 +0,5/0	d ₁ ≈	H 3A	L ≈	M +0.005/0 +0,127/0	
		in/mm							in/mm			
7,94..SP5 ¹⁾	7,94..SP2 ²⁾	2	0.3125 7,938	1.122 28,5	0.591 15	0.394 10	1.654 42	1.654 42	0.449 11,400	7/16-20 11,11-20	2.441 62	0.095 2,4
7,94..SP8 ¹⁾	7,94..SP8 ²⁾	1	0.3125 7,938	1.122 28,5	0.591 15	0.394 10	2.047 52	2.047 52	0.449 11,400	1/2-20 12,7-20	2.913 74	0.095 2,4
7,94..SP12 ¹⁾	7,94..SP9 ²⁾	1	0.3125 7,938	1.122 28,5	0.591 15	0.394 10	2.323 59	2.323 59	0.449 11,400	9/16-18 14,29-18	3.150 80	0.126 3,2
7,94..SP10 ¹⁾	7,94..SP10 ²⁾	1	0.3125 7,938	1.122 28,5	0.591 15	0.394 10	2.480 63	2.480 63	0.449 11,400	5/8-18 15,87-18	3.268 83	0.126 3,2
9,52..SP4 ¹⁾	9,52..SP4 ²⁾	1	0.3750 9,525	1.260 32	0.787 20	0.551 14	1.457 37	1.457 37	0.535 13,589	3/8-24 9,52-24	2.441 62	0.095 2,4
9,52..SP5 ¹⁾	9,52..SP5 ²⁾	1	0.3750 9,525	1.260 32	0.787 20	0.551 14	1.654 42	1.654 42	0.535 13,589	7/16-20 11,11-20	2.638 67	0.095 2,4
9,52..SP6 ¹⁾	9,52..SP6 ²⁾	1	0.3750 9,525	1.260 32	0.787 20	0.551 14	2.047 52	2.047 52	0.535 13,589	1/2-20 12,7-20	2.953 75	0.095 2,4
9,52..SP2 ¹⁾	9,52..SP3 ²⁾	2	0.3750 9,525	1.260 32	0.787 20	0.551 14	1.890 48	1.890 48	0.535 13,589	9/16-18 14,29-18	2.874 73	0.126 3,2
9,52..SP7 ¹⁾	9,52..SP7 ²⁾	1	0.3750 9,525	1.260 32	0.787 20	0.551 14	2.480 63	2.480 63	0.535 13,589	5/8-18 15,87-18	3.346 85	0.126 3,2

¹⁾ For bearing steel bearing and cadmium plated steel rod end body (No code), or for bearing steel bearing and zinc-nickel plated steel rod end body (Code S)

²⁾ For other materials/surface treatments (codes W, SW, X, ZX and SZX)

Designation system

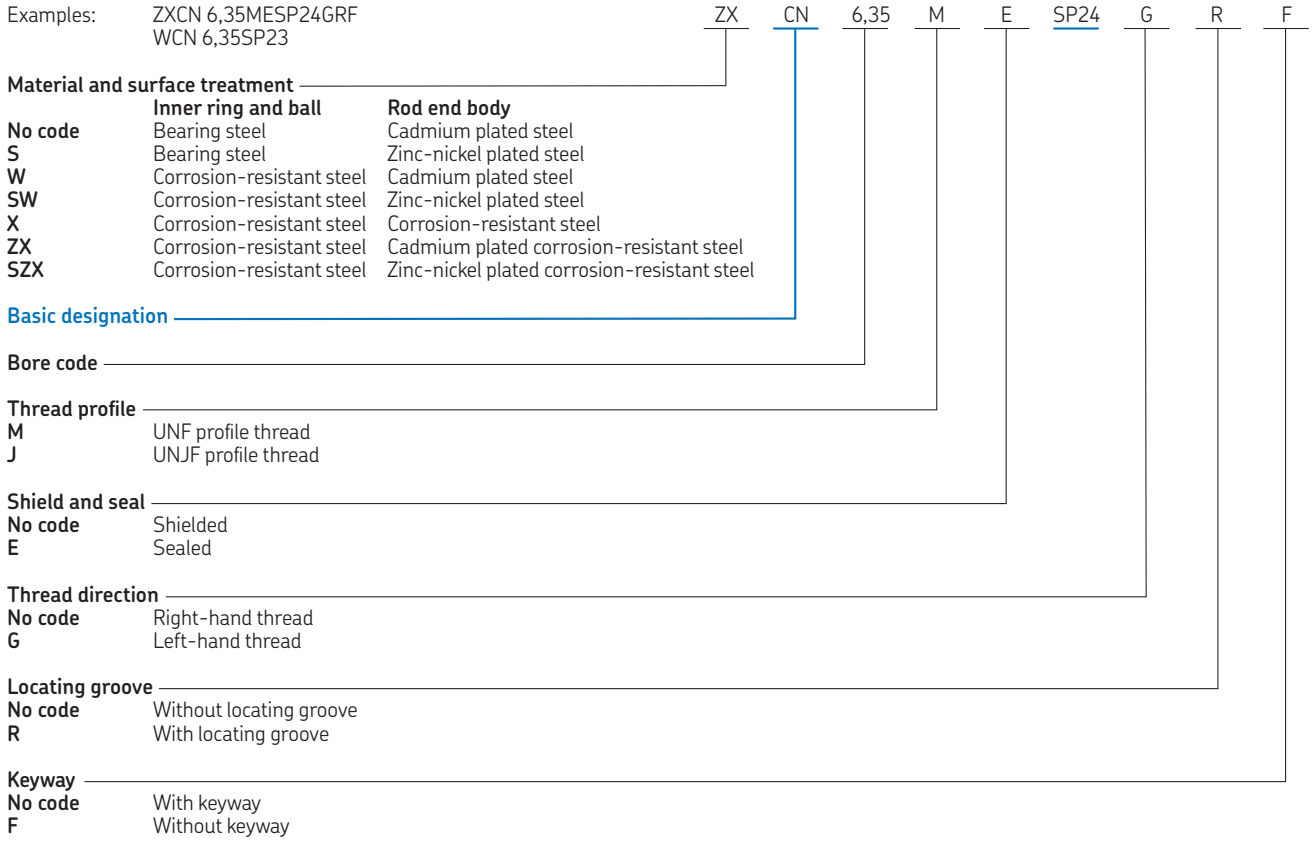

Dimensions cont. loads, torque and clearance

Nominal bore code	Keyway type	Dimensions		α	Mass \approx	Limit static loads		Axial clearance Max	Swivelling torque Max	
		N +0.005/0 +0.127/0	r +0.014/0 +0.35/0			Radial C_s	Axial C_a			
—		in/mm		$^\circ$	lb/g	lbf/kN	in/mm	oz.in/mN.		
7,94..SP5 ¹⁾	7,94..SP2 ²⁾	2	0.370 9,4	0.006 0,15	8	0.08 37	2 424 10,8	764 3,4	0.003 0,080	28.322 200
7,94..SP8 ¹⁾	7,94..SP8 ²⁾	1	0.436 11,07	0.006 0,15	8	0.09 41	2 424 10,8	764 3,4	0.003 0,080	28.322 200
7,94..SP12 ¹⁾	7,94..SP9 ²⁾	1	0.478 12,14	0.006 0,15	8	0.10 46	2 424 10,8	764 3,4	0.003 0,080	28.322 200
7,94..SP10 ¹⁾	7,94..SP10 ²⁾	1	0.539 13,7	0.006 0,15	8	0.12 56	2 424 10,8	764 3,4	0.003 0,080	28.322 200
9,52..SP4 ¹⁾	9,52..SP4 ²⁾	1	0.311 7,9	0.006 0,15	8	0.16 73	3 147 14,0	989 4,4	0.003 0,080	28.322 200
9,52..SP5 ¹⁾	9,52..SP5 ²⁾	1	0.370 9,4	0.006 0,15	8	0.17 77	3 147 14,0	989 4,4	0.003 0,080	28.322 200
9,52..SP6 ¹⁾	9,52..SP6 ²⁾	1	0.436 11,07	0.006 0,15	8	0.22 98	3 147 14,0	989 4,4	0.003 0,080	28.322 200
9,52..SP2 ¹⁾	9,52..SP3 ²⁾	2	0.478 12,14	0.006 0,15	8	0.13 60	3 147 14,0	989 4,4	0.003 0,080	28.322 200
9,52..SP7 ¹⁾	9,52..SP7 ²⁾	1	0.539 13,7	0.006 0,15	8	0.14 64	3 147 14,0	989 4,4	0.003 0,080	28.322 200

3.15 External thread rod end with integrated rolling bearing (inch dimensions)

CN.. bore code 6,35..4 to 6,35..10

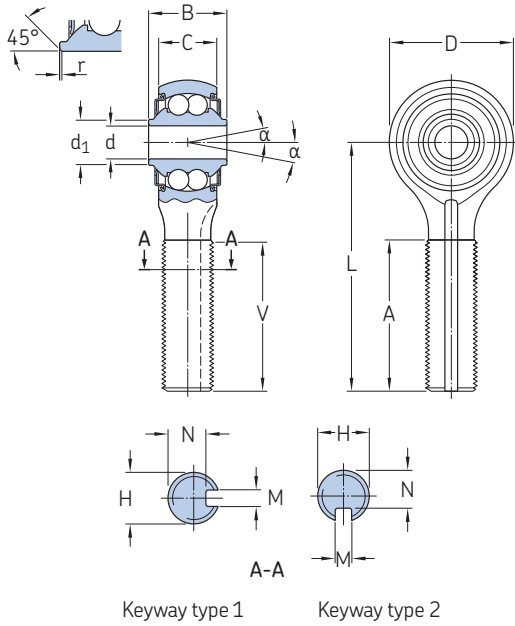

Technical specification	EN 2067
Product standard	EN 4156 (bearing in corrosion-resistant steel) EN 4157 (bearing in bearing steel)

Dimensions

Nominal bore code	Dimensions			D ±0.010 ±0,254	B 0/-0.005 0/-0,127	C ±0.005 ±0,127	A Min	d ₁ ≈
	d	Δdmp	Δds					
in/mm								
6,35..4	0.2500	0/-0.003	0/-0.005	0.886	0.551	0.394	1.063	0.33
	6,350	0/-0,008	0/-0,013	22,5	14	10	27	8,4
6,35..5	0.2500	0/-0.003	0/-0.005	0.886	0.551	0.394	1.457	0.33
	6,350	0/-0,008	0/-0,013	22,5	14	10	37	8,4
6,35..6	0.2500	0/-0.003	0/-0.005	0.886	0.551	0.394	1.457	0.33
	6,350	0/-0,008	0/-0,013	22,5	14	10	37	8,4
6,35..7	0.2500	0/-0.003	0/-0.005	0.886	0.551	0.394	1.654	0.33
	6,350	0/-0,008	0/-0,013	22,5	14	10	42	8,4
6,35..8	0.2500	0/-0.003	0/-0.005	0.886	0.551	0.394	2.047	0.33
	6,350	0/-0,008	0/-0,013	22,5	14	10	52	8,4
6,35..9	0.2500	0/-0.003	0/-0.005	0.886	0.551	0.394	2.323	0.33
	6,350	0/-0,008	0/-0,013	22,5	14	10	59	8,4
6,35..10	0.2500	0/-0.003	0/-0.005	0.886	0.551	0.394	2.480	0.33
	6,350	0/-0,008	0/-0,013	22,5	14	10	63	8,4

Dimensions cont.

Nominal bore code	Dimensions			M +0.005/0 +0,127/0	N +0.005/0 +0,127/0	r	α	Mass ≈
	H UNJF-3A	V ±0.02 ±0,5	L ±0.010 ±0,25					
in/mm								
6,35..4	1/4-28	1.15	2.126	0.063	0.202	0.01/0.02	8	0.08
	6,35-28	29,3	54	1,6	5,11	0,3/0,5		37
6,35..5	5/16-24	1.55	2.126	0.063	0.260	0.01/0.02	8	0.09
	7,94-24	39,3	54	1,6	6,6	0,3/0,5		41
6,35..6	3/8-24	1.55	2.126	0.095	0.311	0.01/0.02	8	0.10
	9,52-24	39,3	54	2,4	7,9	0,3/0,5		46
6,35..7	7/16-20	1.74	2.362	0.095	0.370	0.01/0.02	8	0.12
	11,11-20	44,3	60	2,4	9,4	0,3/0,5		56
6,35..8	1/2-20	2.14	3.051	0.095	0.436	0.01/0.02	8	0.16
	12,7-20	54,3	77,5	2,4	11,07	0,3/0,5		73
6,35..9	9/16-18	2.41	3.346	0.126	0.478	0.01/0.02	8	0.17
	14,29-18	61,3	85	3,2	12,14	0,3/0,5		77
6,35..10	5/8-18	2.57	3.150	0.126	0.539	0.01/0.02	8	0.22
	15,87-18	65,3	80	3,2	13,7	0,3/0,5		98

Designation system

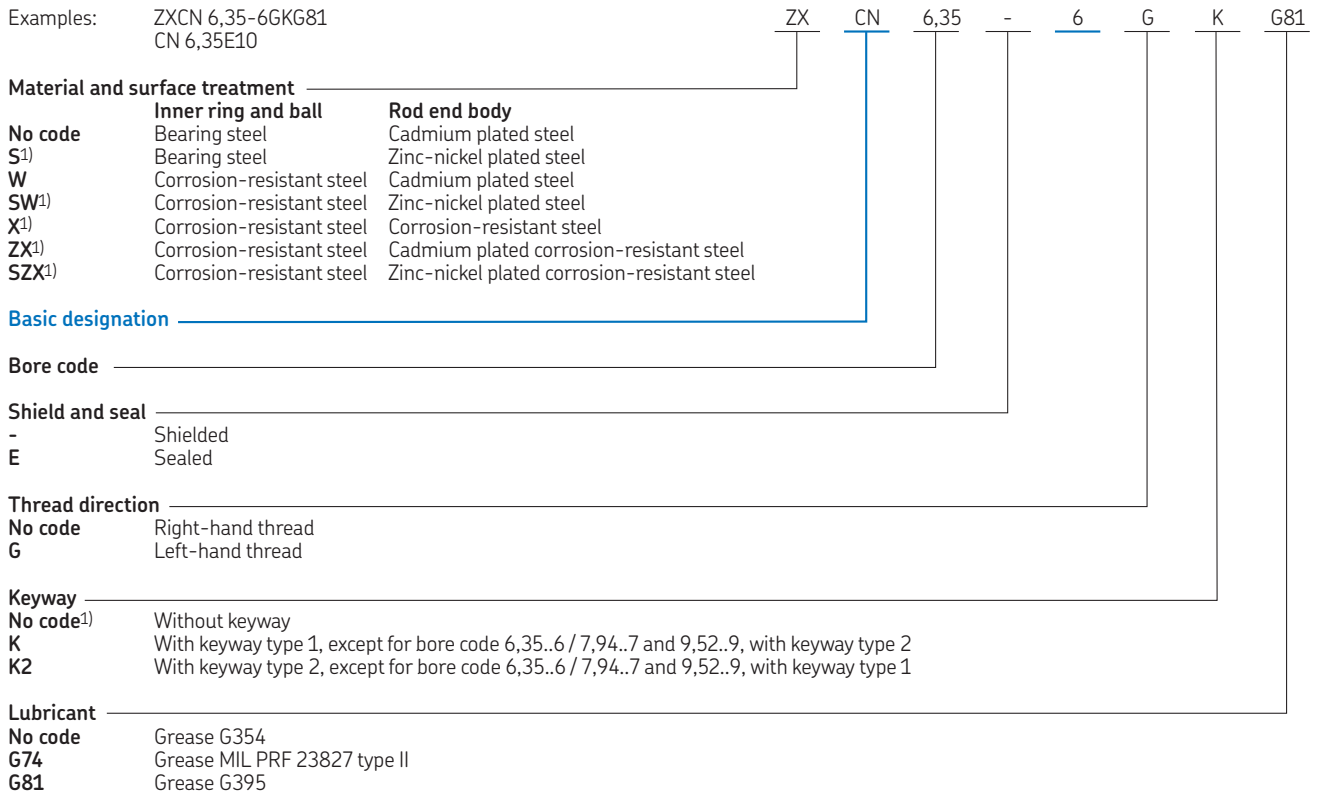

1) SKF option

Loads, torque and clearance

Nominal bore code	Limit static loads		Max. starting torque		Swivelling torque max	Internal Clearances	
	Radial C _s	Axial C _a	Shielded	Sealed		Radial	Axial max
	lbf/kN		oz.in/mN.m			in/mm	
6,35..4	1 531	478	0,283	0,566	21,242	0,00004/0,0002	0,003
	6,810	2,126	2,0	4,0	150	0,001/0,005	0,080
6,35..5	1 531	478	0,283	0,566	21,242	0,00004/0,0002	0,003
	6,810	2,126	2,0	4,0	150	0,001/0,005	0,080
6,35..6	1 531	478	0,283	0,566	21,242	0,00004/0,0002	0,003
	6,810	2,126	2,0	4,0	150	0,001/0,005	0,080
6,35..7	1 531	478	0,283	0,566	21,242	0,00004/0,0002	0,003
	6,810	2,126	2,0	4,0	150	0,001/0,005	0,080
6,35..8	1 531	478	0,283	0,566	21,242	0,00004/0,0002	0,003
	6,810	2,126	2,0	4,0	150	0,001/0,005	0,080
6,35..9	1 531	478	0,283	0,566	21,242	0,00004/0,0002	0,003
	6,810	2,126	2,0	4,0	150	0,001/0,005	0,080
6,35..10	1 531	478	0,283	0,566	21,242	0,00004/0,0002	0,003
	6,810	2,126	2,0	4,0	150	0,001/0,005	0,080

3.15 External thread rod end with integrated rolling bearing (inch dimensions)

CN.. bore code 7,94..5 to 7,94..10

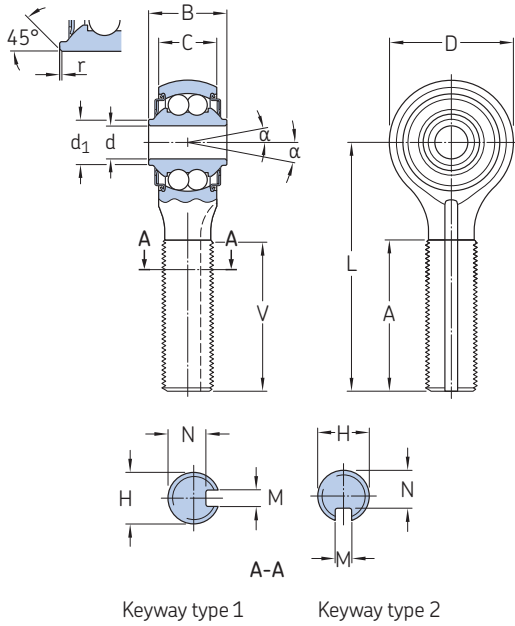

Technical specification	EN 2067
Product standard	EN 4156 (bearing in corrosion-resistant steel) EN 4157 (bearing in bearing steel)

Dimensions

Nominal bore code	Dimensions			D ±0.010 ±0,254	B 0/-0.005 0/-0,127	C ±0.005 ±0,127	A Min	d ₁ ≈
	d	Δdmp	Δds					
–	in/mm							
7,94..5	0.3125 7,938	0/-0.003 0/-0,008	0/-0.005 0/-0,013	1.122 28,5	0.591 15	0.394 10	1.457 37	0.43 10,8
7,94..6	0.3125 7,938	0/-0.003 0/-0,008	0/-0.005 0/-0,013	1.122 28,5	0.591 15	0.394 10	1.457 37	0.43 10,8
7,94..7	0.3125 7,938	0/-0.003 0/-0,008	0/-0.005 0/-0,013	1.122 28,5	0.591 15	0.394 10	1.654 42	0.43 10,8
7,94..8	0.3125 7,938	0/-0.003 0/-0,008	0/-0.005 0/-0,013	1.122 28,5	0.591 15	0.394 10	2.047 52	0.43 10,8
7,94..9	0.3125 7,938	0/-0.003 0/-0,008	0/-0.005 0/-0,013	1.122 28,5	0.591 15	0.394 10	2.323 59	0.43 10,8
7,94..10	0.3125 7,938	0/-0.003 0/-0,008	0/-0.005 0/-0,013	1.122 28,5	0.591 15	0.394 10	2.480 63	0.54 13,8

Dimensions cont.

Nominal bore code	Dimensions						α	Mass ≈	
	H UNJF-3A	V ±0.02 ±0,5	L ±0.010 ±0,25	M +0.005/0 +0,127/0	N +0.005/0 +0,127/0	r			
–	in/mm							°	lb/g
7,94..5	5/16-24 7,94-24	1.55 39,3	2.362 60	0.063 1,6	0.260 6,6	0.01/0.03 0,3/0,8	8	0.13 60	
7,94..6	3/8-24 9,52-24	1.55 39,3	2.362 60	0.095 2,4	0.311 7,9	0.01/0.03 0,3/0,8	8	0.14 64	
7,94..7	7/16-20 11,11-20	1.74 44,3	2.441 62	0.095 2,4	0.370 9,4	0.01/0.03 0,3/0,8	8	0.16 71	
7,94..8	1/2-20 12,7-20	2.14 54,3	2.913 74	0.095 2,4	0.436 11,07	0.01/0.03 0,3/0,8	8	0.19 86	
7,94..9	9/16-18 14,29-18	2.41 61,3	3.150 80	0.126 3,2	0.478 12,14	0.01/0.03 0,3/0,8	8	0.23 103	
7,94..10	5/8-18 15,87-18	2.57 65,3	3.268 83	0.126 3,2	0.539 13,7	0.01/0.03 0,3/0,8	8	0.25 114	

Designation system

Examples: ZXCN 6,35-6GKG81
CN 6,35E10

Material and surface treatment

	Inner ring and ball	Rod end body
No code	Bearing steel	Cadmium plated steel
S ¹⁾	Bearing steel	Zinc-nickel plated steel
W	Corrosion-resistant steel	Cadmium plated steel
SW ¹⁾	Corrosion-resistant steel	Zinc-nickel plated steel
X ¹⁾	Corrosion-resistant steel	Corrosion-resistant steel
ZX ¹⁾	Corrosion-resistant steel	Cadmium plated corrosion-resistant steel
SZX ¹⁾	Corrosion-resistant steel	Zinc-nickel plated corrosion-resistant steel

Basic designation

Bore code

Shield and seal

-	Shielded
E	Sealed

Thread direction

No code	Right-hand thread
G	Left-hand thread

Keyway

No code ¹⁾	Without keyway
K	With keyway type 1, except for bore code 6,35..6 / 7,94..7 and 9,52..9, with keyway type 2
K2	With keyway type 2, except for bore code 6,35..6 / 7,94..7 and 9,52..9, with keyway type 1

Lubricant

No code	Grease G354
G74	Grease MIL PRF 23827 type II
G81	Grease G395

1) SKF option

Loads, torque and clearance

Nominal bore code	Limit static loads		Max. starting torque		Swivelling torque max	Internal Clearances	
	Radial C _s	Axial C _a	Shielded	Sealed		Radial	Axial max
	lbf/kN		oz.in/mN.m			in/mm	
7,94..5	2 424 10,8	764 3,4	0.708 5,0	1.416 10,0	28.322 200	0.00004/0.0002 0,001/0,005	0.003 0,080
7,94..6	2 424 10,8	764 3,4	0.708 5,0	1.416 10,0	28.322 200	0.00004/0.0002 0,001/0,005	0.003 0,080
7,94..7	2 424 10,8	764 3,4	0.708 5,0	1.416 10,0	28.322 200	0.00004/0.0002 0,001/0,005	0.003 0,080
7,94..8	2 424 10,8	764 3,4	0.708 5,0	1.416 10,0	28.322 200	0.00004/0.0002 0,001/0,005	0.003 0,080
7,94..9	2 424 10,8	764 3,4	0.708 5,0	1.416 10,0	28.322 200	0.00004/0.0002 0,001/0,005	0.003 0,080
7,94..10	2 424 10,8	764 3,4	0.708 5,0	1.416 10,0	28.322 200	0.00004/0.0002 0,001/0,005	0.003 0,080

3.15 External thread rod end with integrated rolling bearing (inch dimensions)

CN.. bore code 9,52..6 to 9,52..10

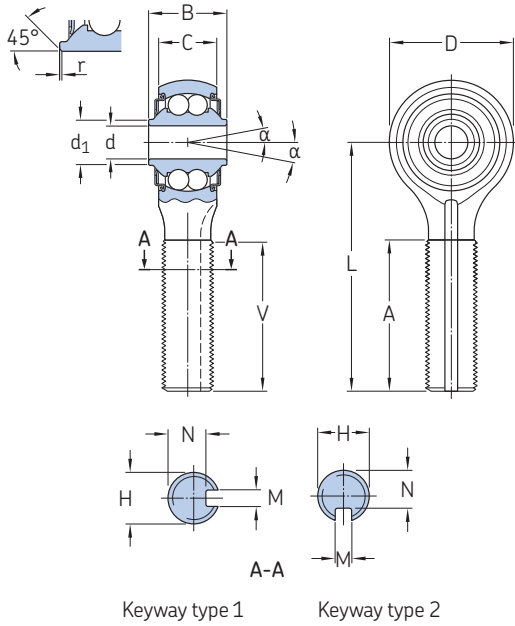

Technical specification	EN 2067
Product standard	EN 4156 (bearing in corrosion-resistant steel) EN 4157 (bearing in bearing steel)

Dimensions

Nominal bore code	Dimensions d	Δd_{mp}	Δd_s	D ± 0.010 $\pm 0,254$	B $0/-0.005$ $0/-0,127$	C ± 0.005 $\pm 0,127$	A Min	d_1 \approx
— in/mm								
9,52..6	0.3750	0/-0.003	0/-0.005	1.260	0.787	0.551	1.457	0.54
	9,525	0/-0,008	0/-0,013	32	20	14	37	13,8
9,52..7	0.3750	0/-0.003	0/-0.005	1.260	0.787	0.551	1.654	0.54
	9,525	0/-0,008	0/-0,013	32	20	14	42	13,8
9,52..8	0.3750	0/-0.003	0/-0.005	1.260	0.787	0.551	2.047	0.54
	9,525	0/-0,008	0/-0,013	32	20	14	52	13,8
9,52..9	0.3750	0/-0.003	0/-0.005	1.260	0.787	0.551	1.890	0.54
	9,525	0/-0,008	0/-0,013	32	20	14	48	13,8
9,52..10	0.3750	0/-0.003	0/-0.005	1.260	0.787	0.551	2.480	0.54
	9,525	0/-0,008	0/-0,013	32	20	14	63	13,8

Dimensions cont.

Nominal bore code	Dimensions H UNJF-3A	V ± 0.02 $\pm 0,5$	L ± 0.010 $\pm 0,25$	M $+0.005/0$ $+0,127/0$	N $+0.005/0$ $+0,127/0$	r	α	Mass \approx
— in/mm								
9,52..6	3/8-24	1.55	2.441	0.095	0.311	0.01/0.03	8	0.21
	9,52-24	39,3	62	2,4	7,9	0,3/0,8		94
9,52..7	7/16-20	1.74	2.638	0.095	0.370	0.01/0.03	8	0.23
	11,11-20	44,3	67	2,4	9,4	0,3/0,8		106
9,52..8	1/2-20	2.14	2.953	0.095	0.436	0.01/0.03	8	0.27
	12,7-20	54,3	75	2,4	11,07	0,3/0,8		122
9,52..9	9/16-18	1.98	2.874	0.126	0.478	0.01/0.03	8	0.29
	14,29-18	50,3	73	3,2	12,14	0,3/0,8		132
9,52..10	5/8-18	2.57	3.346	0.126	0.539	0.01/0.03	8	0.317
	15,87-18	65,3	85	3,2	13,7	0,3/0,8		144

Designation system

Examples: ZXCN 6,35-6GKG81 ZX CN 6,35 - 6 G K G81
 CN 6,35E10

Material and surface treatment

No code	Inner ring and ball	Rod end body
S ¹⁾	Bearing steel	Cadmium plated steel
W	Bearing steel	Zinc-nickel plated steel
SW ¹⁾	Corrosion-resistant steel	Cadmium plated steel
X ¹⁾	Corrosion-resistant steel	Zinc-nickel plated steel
ZX ¹⁾	Corrosion-resistant steel	Corrosion-resistant steel
SZX ¹⁾	Corrosion-resistant steel	Cadmium plated corrosion-resistant steel
		Zinc-nickel plated corrosion-resistant steel

Basic designation

Bore code

Shield and seal

-	Shielded
E	Sealed

Thread direction

No code	Right-hand thread
G	Left-hand thread

Keyway

No code ¹⁾	Without keyway
K	With keyway type 1, except for bore code 6,35..6 / 7,94..7 and 9,52..9, with keyway type 2
K2	With keyway type 2, except for bore code 6,35..6 / 7,94..7 and 9,52..9, with keyway type 1

Lubricant

No code	Grease G354
G74	Grease MIL PRF 23827 type II
G81	Grease G395

1) SKF option

Loads, torque and clearance

Nominal bore code	Limit static loads		Max. starting torque		Swivelling torque max	Internal Clearances	
	Radial C _s	Axial C _a	Shielded	Sealed		Radial	Axial max
-	lbf/kN		oz.in/mN.m		in/mm		
9,52..6	3 147	989	0,991	1,699	28.322	0.00004/0.0002	0.003
	14,0	4,4	7,0	12,0	200	0,001/0,005	0,080
9,52..7	3 147	989	0,991	1,699	28.322	0.00004/0.0002	0.003
	14,0	4,4	7,0	12,0	200	0,001/0,005	0,080
9,52..8	3 147	989	0,991	1,699	28.322	0.00004/0.0002	0.003
	14,0	4,4	7,0	12,0	200	0,001/0,005	0,080
9,52..9	3 147	989	0,991	1,699	28.322	0.00004/0.0002	0.003
	14,0	4,4	7,0	12,0	200	0,001/0,005	0,080
9,52..10	3 147	989	0,991	1,699	28.322	0.00004/0.0002	0.003
	14,0	4,4	7,0	12,0	200	0,001/0,005	0,080

3.16 External thread rod end with integrated rolling bearing (inch dimensions)

REP..M, RA..M, RAP..M

Technical specification	AS 6039
Product standard	AS 21151

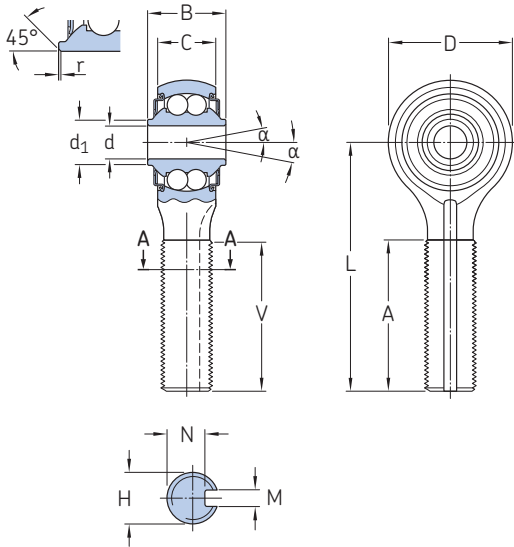

Dimensions

Nominal bore code Without keyway	With keyway	Dimensions								
		d	D	B	C	A	V	d ₁	r	H
		0/-0.0003 0/-0,008	±0.010 ±0,254	0/-0.005 0/-0,127	±0.010 ±0,254	±0.031 ±0,787	+0.02/0 +0,5/0	≈	+0.015/0 + 0,381/0	UNJF-3A
-		in/mm								
REP 3M..3	-	0.1900 4,826	0.781 19,837	0.437 11,100	0.328 8,331	0.750 19,05	0.750 19,05	0.276 7,01	0.005 0,127	10-32
REP 3M..5	-	0.1900 4,826	0.781 19,837	0.437 11,100	0.328 8,331	0.750 19,05	0.750 19,05	0.276 7,01	0.005 0,127	3/16-32
REP 3M..4-6	REP 3M..S4-6	0.1900 4,826	0.781 19,837	0.437 11,100	0.328 8,331	1.000 25,40	1.000 25,40	0.276 7,01	0.005 0,127	1/4-28
REP 3M..6-2N	REP 3MS..6-2N ²⁾ REP 3M..S6 ³⁾	0.1900 4,826	0.781 19,837	0.437 11,100	0.328 8,331	0.750 19,05	0.750 19,05	0.276 7,01	0.005 0,127	3/8-24
RAP 3M..4-2	RAP 3M..S4-2	0.1900 4,826	0.781 19,837	0.500 12,700	0.438 11,125	0.938 23,825	0.938 23,825	0.307 7,80	0.005 0,127	1/4-28
-	RA 3M..5 ¹⁾	0.1900 4,826	0.781 19,837	0.562 14,275	0.438 11,125	1.375 34,925	1.375 34,925	0.307 7,80	0.005 0,127	5/16-24
REP 3M..6A	REP 3M..S6A	0.1900 4,826	0.969 24,613	0.500 12,700	0.407 10,338	1.313 33,350	1.313 33,350	0.299 7,59	0.005 0,127	3/8-24
REP 4M..6	REP 4M..6-4	0.2500 6,350	0.938 23,825	0.593 15,062	0.438 11,125	1.125 28,575	1.125 28,575	0.340 8,64	0.005 0,127	3/8-24
-	RA 4M..7 ¹⁾	0.2500 6,350	0.938 23,825	0.687 17,450	0.531 13,487	1.625 41,275	1.625 41,275	0.430 10,92	0.005 0,127	7/16-20
REP 5M..6	REP 5M..6-2	0.3125 7,938	1.250 31,750	0.870 22,100	0.656 16,662	1.563 39,700	1.563 39,700	0.501 12,73	0.015 0,381	3/8-24
REP 5M..7	REP 5M..S7	0.3125 7,938	1.250 31,750	0.870 22,100	0.656 16,662	1.563 39,700	1.563 39,700	0.501 12,73	0.015 0,381	7/16-20
REP 5M..10	REP 5M..S10	0.3125 7,938	1.250 31,750	0.870 22,100	0.656 16,662	1.563 39,700	1.563 39,700	0.501 12,73	0.015 0,381	5/8-18
REP 8M..10 ¹⁾	-	0.5000 12,700	1.875 47,625	1.000 25,400	0.844 21,438	1.750 44,450	1.750 44,450	0.775 19,68	0.015 0,381	5/8-18
RAP10M..10	RAP10M..S10	0.6250 0,6250	2.000 2,000	1.125 1,125	0.938 0,938	1.500 1,500	1.500 1,500	0.875 22,23	0.015 0,381	5/8-18

1) SKF option 2) For right-hand thread 3) For left-hand thread

Designation system

Examples: XREP 4ML6-4S181CP199
RA 3M5SK1

X REP 4M L 6-4 S181 CP199

Material and surface treatment

No code	Inner ring and ball	Rod end body
S	Bearing steel	Cadmium plated steel
W ¹⁾	Bearing steel	Zinc-nickel plated steel
SW ¹⁾	Corrosion-resistant steel	Cadmium plated steel
X ¹⁾	Corrosion-resistant steel	Zinc-nickel plated steel
		Corrosion-resistant steel

Basic designation

Thread direction

No code ²⁾	Right-hand thread
R ³⁾	Right-hand thread
L	Left-hand thread

Lubricant

SK1	Grease G354
S181	Grease G395

Shield and seal

No code	Sealed
CP199 ¹⁾	Shielded

¹⁾ SKF option

²⁾ For bore codes other than REP3..3

³⁾ For bore code REP3..3

Dimensions cont. loads, torque and clearance

Nominal bore code	Without keyway	With keyway	Dimensions				Mass ≈	Limit static loads		Max internal Clearances		Max. starting torque
			L	M	N	α		Radial C _s	Axial C _a	Radial	Axial	
			±0.010 ±0,254	+0.005/0 + 0,127/0	0/-0.005 0/-0,127	°	lb/g	lbf/kN				
			in/mm						in/mm		oz.in/mN.m	
REP 3M..3	–		1.375 34,925	–	–	10	0.04 18	1 000 4,4	200 0,89	0.0004 0,0101	0.003 0,0762	3 21,18
REP 3M..5	–		1.375 34,925	–	–	10	0.04 18	1 000 4,4	200 0,89	0.0004 0,0101	0.003 0,0762	3 21,18
REP 3M..4-6	REP 3M..S4-6		1.563 39,700	0.062 1,574	0.20 5,105	10	0.05 23	1 000 4,4	200 0,89	0.0004 0,0101	0.003 0,0762	3 21,18
REP 3M..6-2N	REP 3MS..6-2N ²⁾ REP 3M..S6 ³⁾		1.375 34,925	0.093 2,362	0.311 7,89	10	0.05 23	1 000 4,4	200 0,89	0.0004 0,0101	0.003 0,0762	3 21,18
RAP 3M..4-2	RAP 3M..S4-2		1.812 46,025	0.062 1,574	0.20 5,105	10	0.10 45	1 000 4,4	200 0,89	0.0004 0,0101	0.003 0,0762	3 21,18
–	RA 3M..5 ¹⁾		1.938 49,225	0.062 1,574	0.260 6,60	10	0.07 32	1 000 4,4	240 1,07	0.0004 0,0101	0.003 0,0762	3 21,18
REP 3M..6A	REP 3M..S6A		2.031 51,587	0.093 2,362	0.311 7,899	10	0.115 52	1 200 5,3	240 1,07	0.0004 0,0101	0.003 0,0762	3 21,18
REP 4M..6	REP 4M..6-4		1.875 47,625	0.093 2,362	0.311 7,899	10	0.10 45	1 720 7,65	345 1,53	0.0004 0,0101	0.003 0,0762	4 28,24
–	RA 4M..7 ¹⁾		2.250 57,150	0.093 2,362	0.370 9,328	10	0.13 59	1 720 7,65	345 1,53	0.0004 0,0101	0.003 0,0762	4 28,24
REP 5M..6	REP 5M..6-2		2.438 61,925	0.093 2,362	0.311 7,899	10	0.24 109	2 920 12,99	585 2,60	0.0004 0,0101	0.003 0,0762	6 42,36
REP 5M..7	REP 5M..S7		2.438 61,925	0.093 2,362	0.370 9,328	10	0.24 109	2 920 12,99	585 2,60	0.0004 0,0101	0.003 0,0762	6 42,36
REP 5M..10	REP 5M..S10		2.438 61,925	0.125 3,175	0.541 13,741	10	0.24 109	2 920 12,99	585 2,60	0.0004 0,0101	0.003 0,0762	6 42,36
REP 8M..10 ¹⁾	–		3.031 76,987	–	–	10	0.55 249	6 900 30,69	1 380 6,14	0.0004 0,0101	0.003 0,0762	8 56,48
RAP10M..10	RAP10M..S10		2.750 70,150	0.125 3,175	0.541 13,741	10	0.71 31,54	7 090 31,54	1 420 6,32	0.0004 0,0101	0.003 0,0762	8 56,48

3.17 Internal thread rod end with integrated rolling bearing (inch dimensions)

REP, REP..F., REPB..N..

Technical specification	AS 6039
Product standard	AS 21153

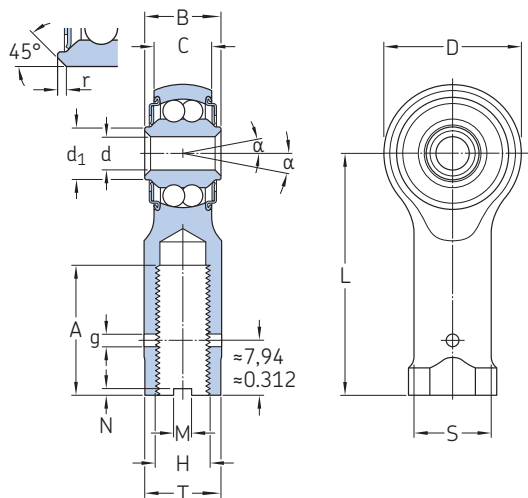

3.17



Dimensions

Nominal bore code	Dimensions										
	d	D	B	C	A	r	g	d ₁	H	L	S
	0/-0.0003	±0.010	0/-0.005	±0.010	±0.031	+0.015/0	≈	=	UNJF-3B	±0.010	±0.010
	0/-0.008	±0.254	0/-0.127	±0.254	±0.79	+0.381/0				±0.254	±0.254
-	in/mm								-	in/mm	
B 3N¹⁾	0.1900	0.781	0.437	0.328	0.812	0.005	0.07	0.276	1/4-28	1.375	0.375
3F...4-3²⁾	4,826	19,837	11,100	8,331	20,625	0,127	1,778	7,01		34,925	9,525
B 3N-2	0.1900	0.781	0.437	0.328	0.812	0.005	0.07	0.276	5/16-24	1.375	0.438
	4,826	19,837	11,100	8,331	20,625	0,127	1,778	7,01		34,925	11,125
3F..4	0.1900	0.781	0.500	0.328	0.812	0.005	0.07	0.276	1/4-28	1.375	0.375
	4,826	19,837	12,700	8,331	20,625	0,127	1,778	7,01		34,925	9,525
4F..5	0.2500	0.938	0.593	0.438	0.812	0.005	0.07	0.340	5/16-24	1.469	0.438
	6,350	23,825	15,062	11,125	20,625	0,127	1,778	8,63		37,313	11,125
4F..7	0.2500	0.938	0.593	0.438	1.125	0.015	0.07	0.340	7/16-20	1.875	0.625
	6,350	23,825	15,062	11,125	28,575	0,381	1,778	8,63		47,625	15,875
5F..5	0.3125	1.250	0.870	0.656	1.000	0.015	0.07	0.501	5/16-24	1.875	0.438
	7,938	31,750	22,100	16,662	25,400	0,381	1,778	12,72		47,625	11,125

¹⁾ For right-hand thread

²⁾ For left-hand thread

Designation system

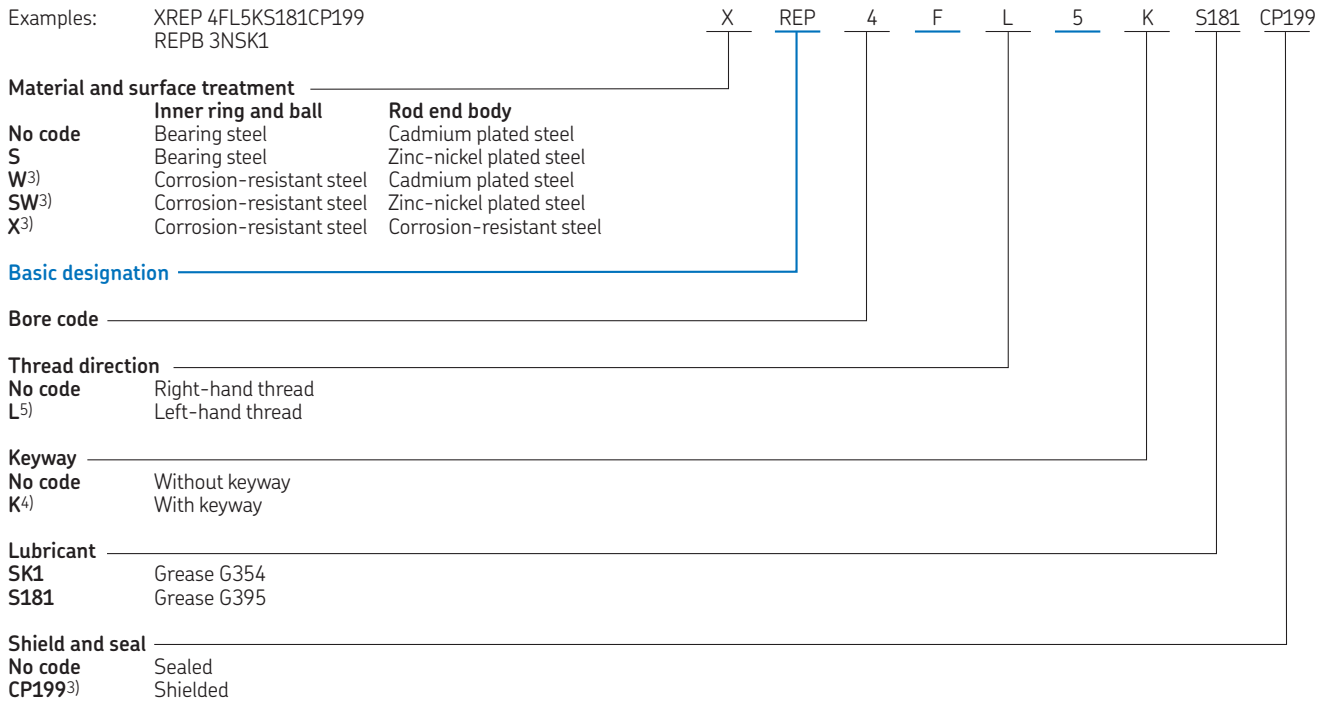

³⁾ SKF option
⁴⁾ Only available for bore code 4..5
⁵⁾ Not available for bore code B3N-2

Dimensions cont. loads, torque and clearance

Nominal bore code	Dimensions			α	Mass \approx	Limit static loads		Maximum Starting Torque	Max internal Clearances	
	T	M	N			Radial C_s	Axial C_a		Radial	Axial
	$\pm 0,010$ $\pm 0,254$	$+0,005/0$ $+ 0,127/0$	$0/-0,005$ $0/-0,127$							
	in/mm			$^\circ$	lb/g	lbf/kN		oz.in/mN.m	in/mm	
B 3N²⁾	0.438	–	–	10	0.05	1 000	200	3	0.0004	0.003
3F...4-3³⁾	11,125	–	–		23	4,45	0,89	21,18	0,010	0,076
B 3N-2	0.438	–	–	10	0.06	1 000	200	3	0.0004	0.003
	11,125	–	–		27	4,45	0,89	21,18	0,010	0,076
3F..4	0.438	–	–	10	0.06	1 000	200	3	0.0004	0.003
	11,125	–	–		27	4,45	0,89	21,18	0,010	0,076
4F..5	0.438	0.062	0.056	10	0.07	1 720	345	4	0.0004	0.003
	11,125	1,57	1,42		32	7,65	1,53	28,24	0,010	0,076
4F..7	0.625	–	–	10	0.08	1 720	345	4	0.0004	0.003
	15,875	–	–		36	7,65	1,53	28,24	0,010	0,076
5F..5	0.438	–	–	10	0.10	2 920	585	6	0.0004	0.003
	11,125	–	–		45	12,99	2,60	42,36	0,010	0,076

3.18 External thread inserted wide metal-to-metal spherical plain bearing rod end (inch dimensions)

EMJ/..ML..R

Technical specification	-
Product standard	-
Bearing	ML..R

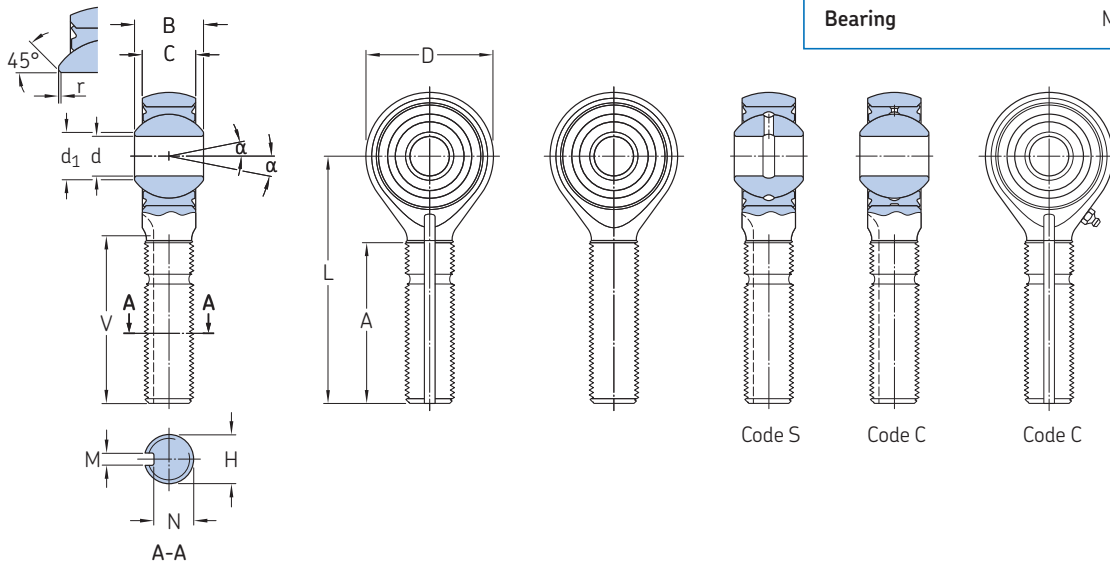

3.18

Dimensions

Nominal bore code	Dash number multiples of 1/16 inch	Dimensions								
		d	D	B	C	A	V	d ₁	r	H
		0/-0.0005	±0.010	0/-0.002	±0.005	+0.06/-0.03	0/-0.020	=	±0.005	UNJF-3A
		0/-0.0127	±0.254	0/-0.051	±0.127	+1.524/-0.762	0/-0.508		±0.127	
		in/mm								
4,83	03	0.1900 4,826	0.806 20,472	0.437 11,100	0.337 8,56	1.000 25,400	1.000 25,400	0.300 7,620	0.010 0,254	5/16-24 7,94-24
6,35	04	0.2500 6,350	0.806 20,472	0.437 11,100	0.337 8,56	1.000 25,400	1.000 25,400	0.300 7,620	0.010 0,254	5/16-24 7,94-24
7,94	05	0.3125 7,938	0.900 22,860	0.437 11,100	0.327 8,306	1.062 26,975	1.062 26,975	0.360 9,140	0.010 0,254	5/16-24 7,94-24
9,52	06	0.3750 9,525	1.025 26,035	0.500 12,700	0.416 10,566	1.250 31,750	1.250 31,750	0.466 11,840	0.010 0,254	3/8-24 9,52-24
11,11	07	0.4375 11,113	1.150 29,210	0.562 14,275	0.452 11,481	1.375 34,925	1.375 34,925	0.537 13,64	0.010 0,254	7/16-20 11,11-20
12,7	08	0.5000 12,700	1.337 33,960	0.625 15,875	0.515 13,081	1.500 38,100	1.500 38,100	0.607 15,420	0.010 0,254	1/2-20 12,7-20
15,87	10	0.6250 15,875	1.525 38,735	0.750 19,050	0.577 14,656	1.625 41,275	1.625 41,275	0.747 18,970	0.010 0,254	5/8-18 15,87-18
19,05	12	0.7500 19,050	1.775 45,085	0.875 22,225	0.640 16,256	1.750 44,450	1.750 44,450	0.845 21,460	0.010 0,254	3/4-16 19,05-16
22,22	14	0.8750 22,225	2.025 51,435	0.875 22,225	0.765 19,431	1.875 47,625	1.875 47,625	0.995 25,270	0.010 0,254	7/8-14 22,22-14
25,4	16	1.0000 25,400	2.775 70,485	1.375 34,925	1.015 25,781	2.125 53,975	2.125 53,975	1.269 32,230	0.010 0,254	1 1/4-12 31,75-12



Designation system

Example:	XEMJ/WQMLS 6,35RGZKX-2		X	EMJ/	WQ	ML	S	6,35	R	G	Z	K	X	-2
	EMJ/WML22,22													
Rod end body material														
No code	Cadmium plated steel													
S	Zinc-nickel plated steel													
X	Corrosion-resistant steel													
T ¹⁾	Anodized titanium													
Basic designation														
Bearing material														
	Inner ring							Outer ring						
W	Corrosion-resistant steel							Corrosion-resistant steel						
Q	Bronze beryllium							Corrosion-resistant steel						
WQ	Corrosion-resistant steel							Bronze aluminium						
Lubrication grooves														
No code	Without lubrication groove													
S	Lubrication by inner ring													
C	Lubrication by rod end body													
Bore code														
Thread direction														
No code	Right-hand thread													
G	Left-hand thread													
Locating groove														
No code	Without locating groove													
Z	With locating groove													
Keyway														
No code	Without keyway													
K	With keyway													
Internal clearance														
No code	Standard clearance													
X	Reduced clearance													
Lubricant														
No code	Grease G354													
-2	Grease G395													

1) SKF option, masses and load carrying capability reduced compared to steel rod end body

Dimensions cont., loads and clearance

Nominal bore code	Dash number multiples of 1/16 inch	Dimensions		N 0/-0.005 0/-0,127	α	Mass ≈	Radial loads		Fatigue 10 ⁶ cycles	Axial clearance	
		L ±0.010 ±0,254	M +0.005/0 +0,127/0				Ultimate ¹⁾			Standard	Reduced
		in/mm				lb/g	lbf/kN			in/μm	
4,83	03	1.562 39,675	0.062 1,575	0.260 6,604	16	0.07 30	6 195 27,56	1 052 4,68	0.0010/0.0040 25/100	0.0020 max 50 max	
6,35	04	1.562 39,675	0.062 1,575	0.260 6,604	16	0.07 30	6 195 27,56	1 052 4,68	0.0010/0.0040 25/100	0.0020 max 50 max	
7,94	05	1.875 47,625	0.062 1,575	0.260 6,604	15	0.08 35	7 585 33,74	1 090 4,85	0.0010/0.0040 25/100	0.0020 max 50 max	
9,52	06	1.938 49,225	0.093 2,362	0.311 7,90	9	0.12 55	8 940 39,78	1 513 6,73	0.0010/0.0040 25/100	0.0020 max 50 max	
11,11	07	2.125 53,975	0.093 2,362	0.370 9,40	11	0.17 75	9 595 42,68	1 920 8,54	0.0010/0.0040 25/100	0.0020 max 50 max	
12,7	08	2.438 61,925	0.093 2,362	0.436 11,074	9	0.28 127	18 750 83,40	3 069 13,65	0.0010/0.0040 25/100	0.0020 max 50 max	
15,87	10	2.625 66,675	0.125 3,175	0.541 13,741	12	0.38 172	20 680 91,99	3 480 15,48	0.0010/0.0040 25/100	0.0020 max 50 max	
19,05	12	2.875 73,025	0.125 3,175	0.663 16,840	13	0.58 263	27 795 123,64	4 586 20,40	0.0010/0.0040 25/100	0.0020 max 50 max	
22,22	14	3.375 85,725	0.156 3,962	0.777 19,735	6	0.81 370	31 725 141,12	5 348 23,79	0.0012/0.0047 30/120	0.0024 max 60 max	
25,4	16	4.125 104,775	0.187 4,750	1.136 28,854	12	2.40 1 100	71 745 319,14	11 990 53,33	0.0012/0.0047 30/120	0.0024 max 60 max	

1) Loads are valid for rod end bodies made of alloy steel or corrosion resistant steel. For other rod ends, refer to page 292

3.19 External thread rod end with inserted metal-to-metal high misalignment spherical plain bearing (inch dimensions)

EMJ/..MT..R

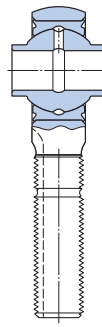
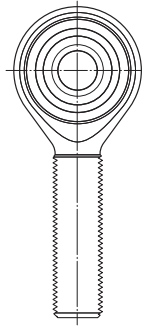
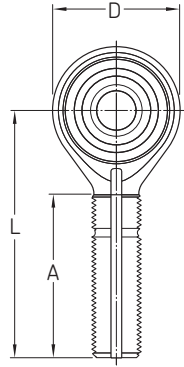
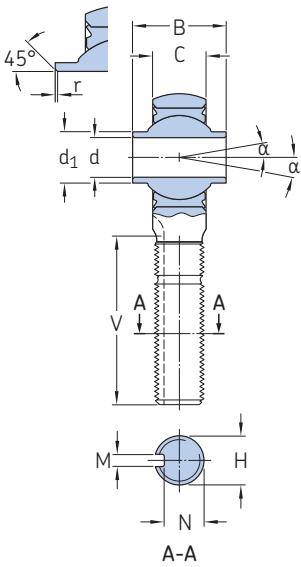

Code S

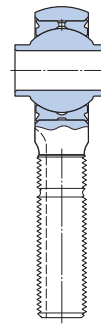

Code C

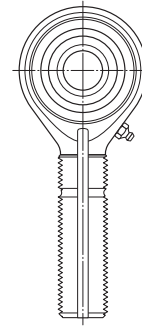

Code C

Technical specification -
Product standard -
Bearing MT..R inch

Dimensions

Nominal bore code	Dash number multiples of 1/16 inch	Dimensions								
		d 0/-0.0005 0/-0,0127	D +0.035/-0.010 +0,889/-0,254	B 0/-0.005 0/-0,127	C ±0.005 ±0,127	A +0.06/-0.03 +1,524/-0,762	V 0/-0.020 0/-0,508	d ₁ ≈	r +0.012/0 +0,230/0	H UNJF-3A
in/mm										
4,83	03	0.1900	0.750	0.500	0.220	1.000	1.000	0.315	0.004	5/16-24
		4,826	19,050	12,700	5,588	25,400	25,400	8,000	0,100	7,94-24
6,35	04	0.2500	1.000	0.593	0.265	1.250	1.250	0.386	0.004	3/8-24
		6,350	25,400	15,062	6,731	31,750	31,750	9,800	0,100	9,52-24
7,94	05	0.3125	1.125	0.813	0.355	1.375	1.375	0.512	0.004	7/16-20
		7,938	28,575	20,650	9,017	34,925	34,925	13,000	0,100	11,11-20
9,52	06	0.3750	1.125	0.813	0.355	1.375	1.375	0.532	0.004	7/16-20
		9,525	28,575	20,650	9,017	34,925	34,925	13,500	0,100	11,11-20
11,11	07	0.4375	1.312	0.875	0.355	1.500	1.500	0.620	0.004	1/2-20
		11,113	33,325	22,225	9,017	38,100	38,100	15,750	0,100	12,7-20
12,7	08	0.5000	1.500	0.937	0.411	1.625	1.625	0.728	0.004	5/8-18
		12,700	38,100	23,799	10,439	41,275	41,275	18,480	0,100	15,87-18
15,87	10	0.6250	1.750	1.200	0.577	1.750	1.750	0.857	0.004	3/4-16
		15,875	44,450	30,480	14,656	44,450	44,450	21,770	0,100	19,05-16
19,05	12	0.7500	2.000	1.280	0.630	1.875	1.875	0.963	0.004	7/8-14
		19,050	50,800	32,512	16,002	47,625	47,625	24,450	0,100	22,22-14
22,22	14	0.8750	2.200	1.400	0.635	2.000	2.000	1.122	0.004	7/8-14
		22,225	55,880	35,560	16,129	50,800	50,800	28,490	0,100	22,22-14
25,4	16	1.0000	2.750	1.875	0.845	2.125	2.125	1.272	0.004	1 1/4-12
		25,400	69,850	47,625	21,463	53,975	53,975	32,320	0,100	31,75-12

Designation system

Example: XEMJ/WQMLS 6,35RGZKX-2 X EMJ/ WQ ML S 6,35 R G Z K X -2
EMJ/WML22,22

Rod end body material

No code Cadmium plated steel
S Zinc-nickel plated steel
X Corrosion-resistant steel
T¹⁾ Anodized titanium

Basic designation

Bearing material

	Inner ring	Outer ring
W	Corrosion-resistant steel	Corrosion-resistant steel
Q	Bronze beryllium	Corrosion-resistant steel
WQ	Corrosion-resistant steel	Bronze aluminium

Lubrication grooves

No code Without lubrication groove
S Lubrication by inner ring
C Lubrication by rod end body

Bore code

Thread direction

No code Right-hand thread
G Left-hand thread

Locating groove

No code Without locating groove
Z With locating groove

Keyway

No code Without keyway
K With keyway

Internal clearance

No code Standard clearance
X Reduced clearance

Lubricant

No code Grease G354
-2 Grease G395

1) SKF option, masses and load carrying capability reduced compared to steel rod end body

Dimensions cont., loads and clearance

Nominal bore code	Dash number multiples of 1/16 inch	Dimensions		N	α	Mass ≈	Radial loads		Axial clearance	
		L	M				Ultimate ¹⁾	Fatigue 10 ⁶ cycles	Standard	Reduced
		±0.010 ±0,254	+0.005/0 +0,127/0	0/-0.005 0/-0,127						
–		in/mm			°	lb/g	lbf/kN		in/μm	
4,83	03	1.500 38,100	0.062 1,575	0.260 6,604	15	0.06 27	4 800 21,35	762 3,39	0.0010/0.0040 25/100	0.0020 max 50 max
6,35	04	1.938 49,225	0.093 2,362	0.311 7,899	24	0.11 50	8 185 36,41	1 311 5,83	0.0010/0.0040 25/100	0.0020 max 50 max
7,94	05	2.125 53,975	0.093 2,362	0.370 9,400	23	0.16 73	8 620 38,34	1 414 6,29	0.0010/0.0040 25/100	0.0020 max 50 max
9,52	06	2.125 53,975	0.093 2,362	0.370 9,40	22	0,16 73	8 620 38,34	1 414 6,29	0.0010/0.0040 25/100	0.0020 max 50 max
11,11	07	2,438 61,925	0,093 2,362	0,436 11,07	22	0,25 114	13 025 57,94	2 104 9,36	0.0010/0.0040 25/100	0.0020 max 50 max
12,7	08	2,625 66,675	0,125 3,175	0,541 13,741	20	0,41 186	18 165 80,80	2 947 13,11	0.0010/0.0040 25/100	0.0020 max 50 max
15,87	10	2,875 73,025	0,125 3,175	0,663 16,840	20	0,64 290	24 010 106,80	3 973 17,67	0.0010/0.0040 25/100	0.0020 max 50 max
19,05	12	3,375 85,725	0,156 3,962	0,777 19,735	19	0,92 417	26 990 120,06	5 052 22,47	0.0010/0.0040 25/100	0.0020 max 50 max
22,22	14	3,750 95,250	0,156 3,962	0,777 19,735	19	1,11 508	28 880 128,46	5 295 23,55	0.0012/0.0047 30/120	0.0024 max 60 max
25,4	16	4,125 104,775	0,187 4,750	1,136 28,854	21	2,14 970	60 230 267,92	9 858 43,85	0.0012/0.0047 30/120	0.0024 max 60 max

1) Loads are valid for rod end bodies made of alloy steel or corrosion resistant steel. For other rod ends, refer to page 292

3.20 Internal thread inserted wide metal-to-metal spherical plain bearing rod end (inch dimensions)

EFJ/..ML..R

Technical specification	-
Product standard	-
Bearing	ML..R

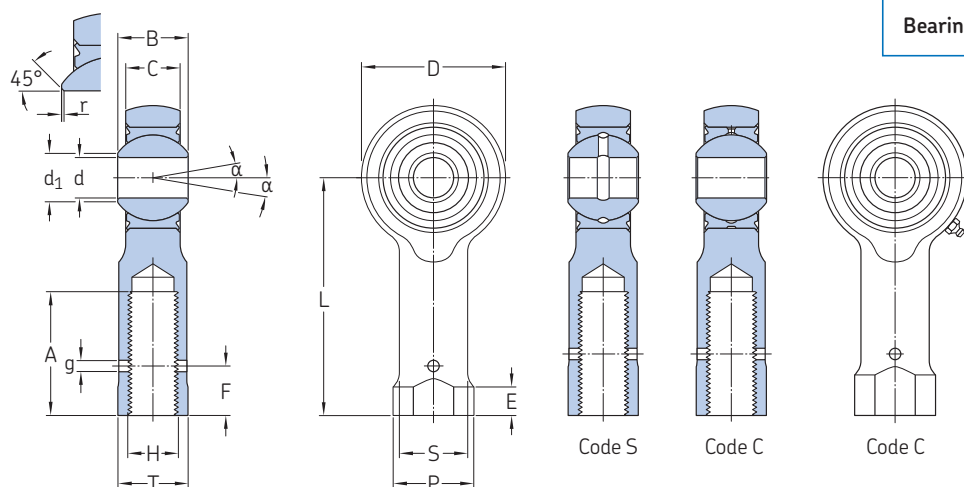

3.20

Dimensions

Nominal bore code	Dash number multiples of 1/16 inch	Dimensions										
		d	D	B	C	A	d ₁	r	g	H	L	
		0/-0.0005	±0.010	0/-0.002	±0.005	+0.06/-0.03	d ₁	±0.005	g	H	L	
		0/-0.0127	±0,254	0/-0,051	±0,127	+1,524/-0,762	≈	±0,127	≈	UNJF-3B	±0.010 ±0,254	
-		in/mm									-	in/mm
4,83	03	0.1900	0.806	0.437	0.337	0.750	0.300	0.010	0.07	5/16-24	1.375	
		4,826	20,472	11,100	8,56	19,050	7,620	0,254	1,778	7,94-24	34,925	
6,35	04	0.2500	0.806	0.437	0.337	0.750	0.300	0.010	0.07	5/16-24	1.469	
		6,350	20,472	11,100	8,56	19,050	7,620	0,254	1,778	7,94-24	37,312	
7,94	05	0.3125	0.900	0.437	0.327	0.750	0.360	0.010	0.07	5/16-24	1.375	
		7,938	22,860	11,100	8,306	19,050	9,140	0,254	1,778	7,94-24	34,925	
9,52	06	0.3750	1.025	0.500	0.416	0.937	0.466	0.010	0.07	3/8-24	1.625	
		9,525	26,035	12,700	10,566	23,780	11,840	0,254	1,778	9,52-24	41,275	
11,11	07	0.4375	1.150	0.562	0.452	1.062	0.537	0.010	0.07	7/16-20	1.812	
		11,113	29,210	14,275	11,481	26,975	13,64	0,254	1,778	11,11-20	46,025	
12,7	08	0.5000	1.337	0.625	0.515	1.125	0.607	0.010	0.07	1/2-20	2.125	
		12,700	33,960	15,875	13,081	28,575	15,420	0,254	1,778	12,7-20	53,975	
15,87	10	0.6250	1.525	0.750	0.577	1.500	0.747	0.010	0.07	5/8-18	2.625	
		15,875	38,735	19,050	14,656	38,100	18,970	0,254	1,778	15,87-18	66,675	
19,05	12	0.7500	1.775	0.875	0.640	1.620	0.845	0.010	0.07	3/4-16	2.875	
		19,050	45,085	22,225	16,256	41,148	21,460	0,254	1,778	19,05-16	73,025	
22,22	14	0.8750	2.025	0.875	0.765	1.875	0.995	0.010	0.07	7/8-14	3.375	
		22,225	51,435	22,225	19,431	47,625	25,270	0,254	1,778	22,22-14	85,725	
25,4	16	1.0000	2.775	1.375	1.015	2.125	1.269	0.010	0.07	1-12	4.125	
		25,400	70,485	34,925	25,781	53,975	32,230	0,254	1,778	25,4-12	104,775	

Designation system

Examples: XEFJ/WQMLS 6,35RGX-2
XEFJ/WML22,22

X EFJ/ WQ ML S 6,35 R G X -2

Rod end body material

No code Cadmium plated steel
S Zinc-nickel plated steel
X Corrosion-resistant steel
T¹⁾ Anodized titanium

Basic designation

Bearing material

	Inner ring	Outer ring
W	Corrosion-resistant steel	Corrosion-resistant steel
Q	Bronze beryllium	Corrosion-resistant steel
WQ	Corrosion-resistant steel	Bronze aluminium

Lubrication grooves

No code Without lubrication groove
S Lubrication by inner ring
C Lubrication by rod end body

Bore code

Thread direction

No code Right-hand thread
G Left-hand thread

Internal clearance

No code Standard clearance
X Reduced clearance

Lubricant

No code Grease G354
-2 Grease G395

1) SKF option, masses and load carrying capability reduced compared to steel rod end body

Dimensions cont., loads and clearance

Nominal bore code	Dash number multiples of 1/16 inch	Dimensions		E	S	T	α	Mass ≈	Radial loads		Axial clearance	
		P	F						Ultimate ¹⁾	Fatigue 10 ⁶ cycles	Standard	Reduced
		in/mm				°		lb/g	lbf/kN	in/μm		
4,83	03	0.500	0.380	0.25	0.422	0.437	16	0.07	6 195	1 052	0.0010/0.0040	0.0020 max
		12,700	9,652	6,35	10,719	11,100						
6,35	04	0.500	0.380	0.25	0.422	0.437	16	0.07	6 195	1 052	0.0010/0.0040	0.0020 max
		12,700	9,652	6,35	10,719	11,100						
7,94	05	0.500	0.380	0.25	0.422	0.437	15	0.10	7 585	1 090	0.0010/0.0040	0.0020 max
		12,700	9,652	6,35	10,719	11,100						
9,52	06	0.625	0.440	0.25	0.567	0.582	9	0.12	8 940	1 513	0.0010/0.0040	0.0020 max
		15,875	11,176	6,35	14,402	14,782						
11,11	07	0.687	0.500	0.25	0.610	0.625	11	0.20	9 595	1 920	0.0010/0.0040	0.0020 max
		17,450	12,700	6,35	15,494	15,875						
12,7	08	0.812	0.560	0.25	0.735	0.750	9	0.28	18 750	3 069	0.0010/0.0040	0.0020 max
		20,625	14,224	6,35	18,669	19,050						
15,87	10	1.000	0.690	0.25	0.860	0.875	12	0.45	20 680	3 480	0.0010/0.0040	0.0020 max
		25,400	17,526	6,35	21,844	22,225						
19,05	12	1.060	0.820	0.25	0.985	1.000	13	0.55	27 795	4 586	0.0010/0.0040	0.0020 max
		26,924	20,828	6,35	25,019	25,400						
22,22	14	1.187	0.940	0.25	1.110	1.125	6	1.00	31 725	5 348	0.0012/0.0047	0.0024 max
		30,150	23,876	6,35	28,194	28,575						
25,4	16	1.312	1.070	0.25	1.235	1.250	12	1.45	71 745	8 377	0.0012/0.0047	0.0024 max
		33,325	27,178	6,35	31,369	31,750						

1) Loads are valid for rod end bodies made of alloy steel or corrosion resistant steel. For other rod ends, refer to page 292

3.21 Internal thread inserted high misalignment metal-to-metal spherical plain bearing rod end (inch dimensions)

EFJ/..MT..R

Technical specification	-
Product standard	-
Bearing	MT..R inch

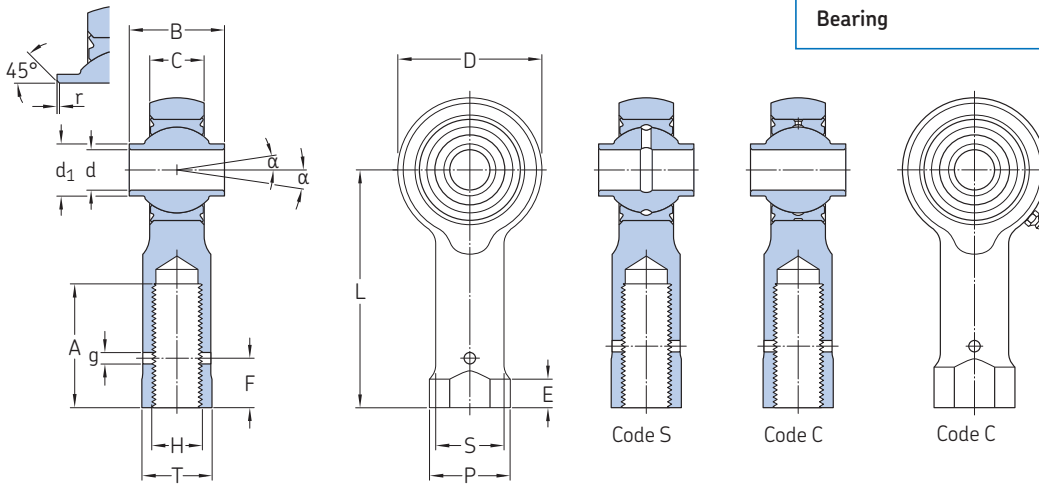

3.21

Dimensions

Nominal bore code	Dash number multiples of 1/16 inch	Dimensions					d ₁ ≈	r	g	H	L
		d	D	B	C	A					
		0/-0.0005	+0.035/-0.010	0/-0.005	±0.005	+0.06/-0.03		+0.012/0		UNJF-3B	±0.010
		0/-0.0127	+0.889/-0.254	0/-0.127	±0.127	+1.524/-0.762		+0.230/0			±0.254
		in/mm									
		in/mm									
4,83	03	0.1900	0.750	0.500	0.220	0.750	0.315	0.004	0.07	5/16-24	1.375
		4,826	19,050	12,700	5,588	19,050	8,000	0,100	1,778	7,94-24	34,925
6,35	04	0.2500	1.000	0.593	0.265	0.937	0.386	0.004	0.07	3/8-24	1.625
		6,350	25,400	15,062	6,731	23,780	9,800	0,100	1,778	9,52-24	41,275
7,94	05	0.3125	1.125	0.813	0.355	1.062	0.512	0.004	0.07	7/16-20	1.812
		7,938	28,575	20,650	9,017	26,975	13,000	0,100	1,778	11,11-20	46,025
9,52	06	0.3750	1.125	0.813	0.355	1.062	0.532	0.004	0.07	7/16-20	1.812
		9,525	28,575	20,650	9,017	26,975	13,500	0,100	1,778	11,11-20	46,025
11,11	07	0.4375	1.312	0.875	0.355	1.125	0.620	0.004	0.07	1/2-20	2.125
		11,113	33,325	22,225	9,017	28,575	15,750	0,100	1,778	12,7-20	53,975
12,7	08	0.5000	1.500	0.937	0.411	1.500	0.728	0.004	0.07	5/8-18	2.625
		12,700	38,100	23,799	10,439	38,100	18,480	0,100	1,778	15,87-18	66,675
15,87	10	0.6250	1.750	1.200	0.577	1.750	0.857	0.004	0.07	3/4-16	2.875
		15,875	44,450	30,480	14,656	44,450	21,770	0,100	1,778	19,05-16	73,025
19,05	12	0.7500	2.000	1.280	0.630	1.875	0.963	0.004	0.07	7/8-14	2.875
		19,050	50,800	32,512	16,002	47,625	24,450	0,100	1,778	22,22-14	73,025
22,22	14	0.8750	2.200	1.400	0.635	2.000	1.122	0.004	0.07	7/8-14	3.375
		22,225	55,880	35,560	16,129	50,800	28,490	0,100	1,778	22,22-14	85,725
25,4	16	1.0000	2.750	1.875	0.845	2.125	1.272	0.004	0.07	1 1/4-12	4.125
		25,400	69,850	47,625	21,463	53,975	32,320	0,100	1,778	31,75-12	104,775

Designation system

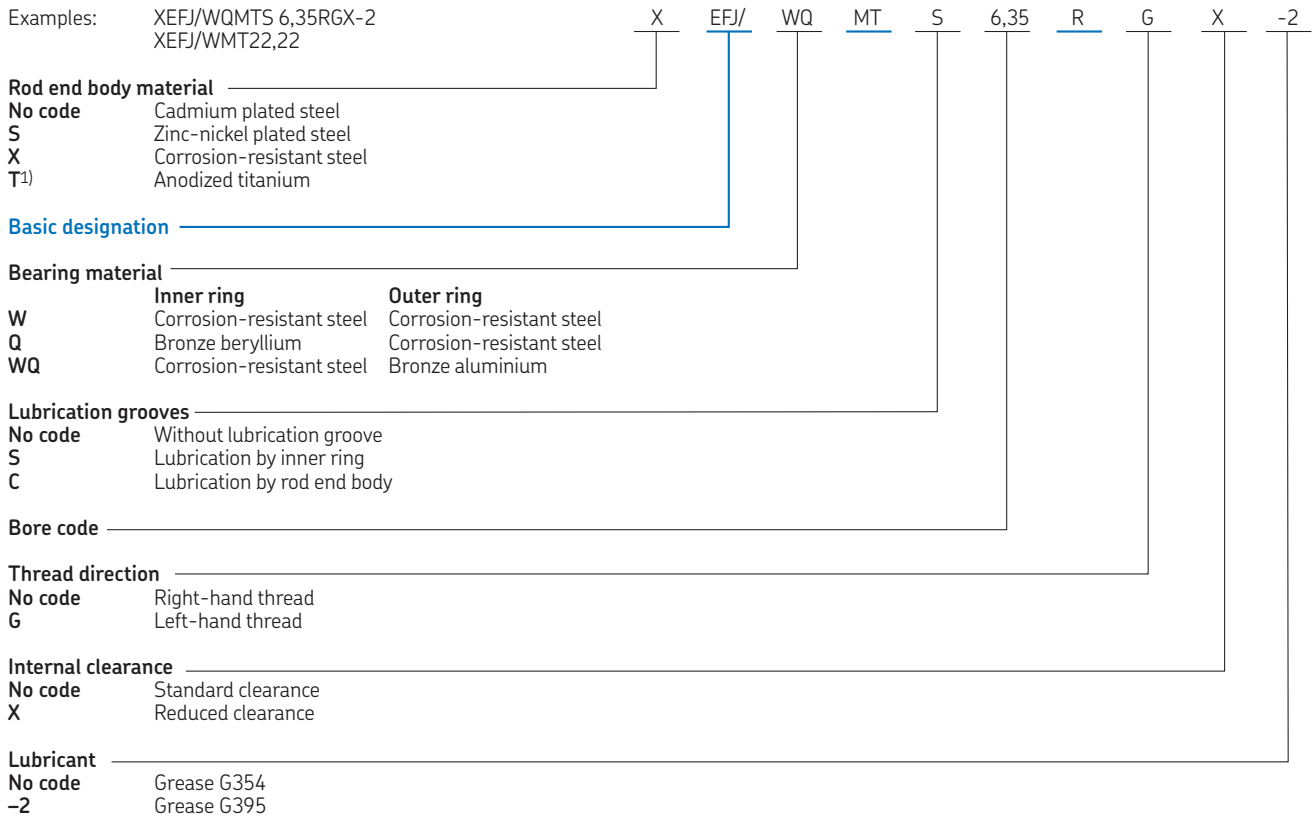

1) SKF option, masses and load carrying capability reduced compared to steel rod end body

Dimensions cont., loads and clearance

Nominal bore code	Dash number multiples of 1/16 inch	Dimensions		E ≈	S ±0,005 ±0,127	T ±0,010 ±0,254	α	Mass ≈	Radial loads		Axial clearance	
		P ±0,010 ±0,254	F ±0,015 ±0,381						Ultimate ¹⁾	Fatigue 10 ⁶ cycles	Standard	Reduced
		in/mm				°	lb/g	lbf/kN			in/μm	
4,83	03	0.500 12,700	0.380 9,652	0.25 6,35	0.422 10,719	0.437 11,100	15	0.07 31	4 800 21,35	762 3,39	0.0010/0.0040 25/100	0.0020 max 50 max
6,35	04	0.625 15,875	0.440 11,176	0.25 6,35	0.567 14,402	0.582 14,782	24	0.13 60	8 185 36,41	1 311 5,83	0.0010/0.0040 25/100	0.0020 max 50 max
7,94	05	0.687 17,450	0.500 12,700	0.25 6,35	0.610 15,494	0.625 15,875	23	0.19 85	8 620 38,34	1 414 6,29	0.0010/0.0040 25/100	0.0020 max 50 max
9,52	06	0.687 17,450	0.500 12,700	0.25 6,35	0.610 15,494	0.625 15,875	22	0.19 85	8 620 38,34	1 414 6,29	0.0010/0.0040 25/100	0.0020 max 50 max
11,11	07	0.812 20,625	0.560 14,224	0.25 6,35	0.735 18,669	0.750 19,050	22	0.31 140	13 025 57,94	2 104 9,36	0.0010/0.0040 25/100	0.0020 max 50 max
12,7	08	1.000 25,400	0.690 17,526	0.25 6,35	0.860 21,844	0.875 22,225	20	0.49 220	18 165 80,80	2 947 13,11	0.0010/0.0040 25/100	0.0020 max 50 max
15,87	10	1.060 26,924	0.820 20,828	0.25 6,35	0.985 25,019	1.000 25,400	20	0.71 321	24 010 106,80	3 973 17,67	0.0010/0.0040 25/100	0.0020 max 50 max
19,05	12	1.187 30,150	0.940 23,876	0.25 6,35	1.110 28,194	1.125 28,575	19	0.97 440	26 990 120,06	5 052 22,47	0.0010/0.0040 25/100	0.0020 max 50 max
22,22	14	1.187 30,150	0.940 23,876	0.25 6,35	1.110 28,194	1.125 28,575	19	1.11 501	28 880 128,46	5 295 23,55	0.0012/0.0047 30/120	0.0024 max 60 max
25,4	16	2.020 51,308	1.070 27,178	0.25 6,35	1.688 42,875	1.250 31,750	21	2.00 908	60 230 267,92	9 858 43,85	0.0012/0.0047 30/120	0.0024 max 60 max

1) Loads are valid for rod end bodies made of alloy steel or corrosion resistant steel. For other rod ends, refer to page 292

3.22 External thread inserted wide self-lubricating spherical plain bearing rod end (inch dimensions)

MJ/WAS.. (UMJ/XRL.. or 12BM..)1)

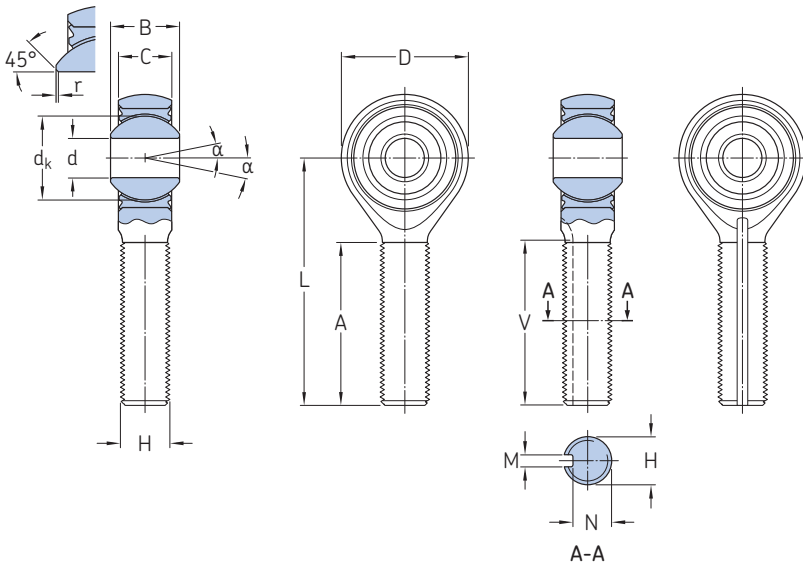

Technical specification	AS 81935
Product standard	AS 81935/1
Bearing	WAS..R inch (440C inner ring) EWAS..R inch (PH13.8 inner ring)

Dimensions

Nominal Dimensions

bore code	d	D	B	C	A	dk	r	H	L
	0/-0.0005	±0.010	0/-0.002	±0.005	±0.031	≈	±0.005	UNJF-3A	±0.010
	0/-0.0127	±0.254	0/-0.051	±0.127	±0.79		±0.127		±0.254

– in/mm

– in/mm

03	0.1900 4,826	0.806 20,472	0.437 11,100	0.337 8,56	0.968 24,587	0.530 13,464	0.010 0,254	5/16-24 7,94-24	1.562 39,675
04	0.2500 6,350	0.806 20,472	0.437 11,100	0.337 8,56	0.968 24,587	0.530 13,464	0.010 0,254	5/16-24 7,94-24	1.562 39,675
05	0.3125 7,938	0.900 22,860	0.437 11,100	0.327 8,306	1.187 30,150	0.566 14,381	0.010 0,254	5/16-24 7,94-24	1.875 47,625
06	0.3750 9,525	1.025 26,035	0.500 12,700	0.416 10,566	1.187 30,150	0.683 17,361	0.010 0,254	3/8-24 9,52-24	1.938 49,225
07	0.4375 11,113	1.150 29,210	0.562 14,275	0.452 11,481	1.281 32,537	0.777 19,744	0.010 0,254	7/16-20 11,11-20	2.125 53,975
08	0.5000 12,700	1.337 33,960	0.625 15,875	0.515 13,081	1.468 37,287	0.871 22,130	0.010 0,254	1/2-20 12,7-20	2.438 61,925
10	0.6250 15,875	1.525 38,735	0.750 19,050	0.577 14,656	1.562 39,675	1.059 26,887	0.010 0,254	5/8-18 15,87-18	2.625 66,675
12	0.7500 19,050	1.775 45,085	0.875 22,225	0.640 16,256	1.687 42,850	1.216 30,897	0.010 0,254	3/4-16 19,05-16	2.875 73,025
14	0.8750 22,225	2.025 51,435	0.875 22,225	0.765 19,431	2.000 50,800	1.325 33,655	0.010 0,254	7/8-14 22,22-14	3.375 85,725
16	1.0000 25,400	2.775 70,485	1.375 34,925	1.015 25,781	2.343 59,512	1.871 47,526	0.010 0,254	1 1/4-12 31,75-12	4.125 104,775

1) Parts are delivered and marked with UMJ/XRL.. and 12BM.. standard references

Cross-reference designation system to UMJ/XRL.. or 12BM..

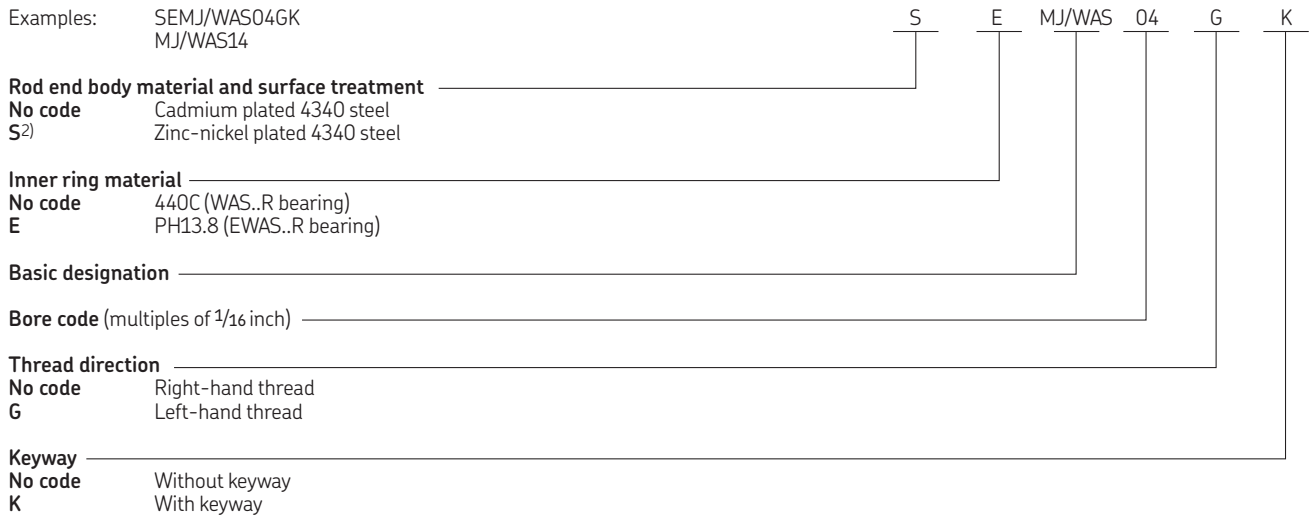

2) SKF option

3.22



Dimensions cont., loads and torque

Nominal bore code	Dimensions			α	Mass \approx	Radial loads Ultimate	Fatigue 50 000 cycles	Starting torque
	M	N	V					
	+0.005/0 +0,127/0	0/-0.005 0/-0,127	0/-0.020 0/-0,508					
–	in/mm			°	lb/g	lbf/kN		lbf-in/Nm
03	0.062 1,575	0.268 6,807	0.980 24,892	15	0.072 33	2 360 10,50	1 470 6,54	0.5/6 0,056/0,678
04	0.062 1,575	0.268 6,807	0.980 24,892	15	0.072 33	4 860 21,62	2 380 10,59	0.5/6 0,056/0,678
05	0.062 1,575	0.268 6,807	1.270 32,258	14	0.087 39	7 180 31,95	2 770 12,32	1/15 0,113/1,695
06	0.093 2,362	0.319 8,103	1.235 31,369	8	0.136 62	8 550 38,05	3 570 15,88	1/15 0,113/1,695
07	0.093 2,362	0.383 9,728	1.402 35,611	10	0.188 83	12 000 53,4	4 800 21,35	1/15 0,113/1,695
08	0.093 2,362	0.445 11,303	1.589 40,361	9	0.278 126	19 500 86,70	7 680 34,16	1/15 0,113/1,695
10	0.125 3,175	0.541 13,741	1.683 42,748	12	0.424 192	21 900 97,45	9 180 40,83	1/15 0,113/1,695
12	0.125 3,175	0.663 16,840	1.808 45,923	13	0.639 290	29 300 130,38	11 600 51,60	1/15 0,113/1,695
14	0.156 3,962	0.777 19,736	2.121 53,873	6	0.963 437	34 500 153,52	13 100 58,27	1/24 0,113/2,712
16	0.187 4,750	1.136 28,854	2.464 62,586	12	2.546 1 150	80 300 357,31	30 400 135,22	1/24 0,113/2,712

3.23 External thread inserted wide self-lubricating spherical plain bearing rod end (inch dimensions)

PHMJ/WAS.. (PHUMJ/XRL.. or 12CM..)¹

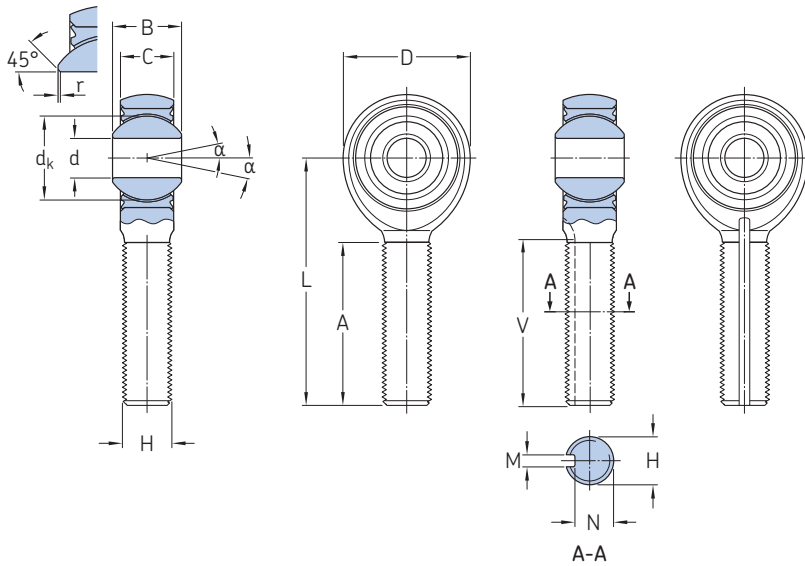

Technical specification	AS 81935
Product standard	AS 81935/6
Rod end material	PH13.8 passivated
Bearing	WAS..R inch (440C inner ring) EWAS..R inch (PH13.8 inner ring)

Dimensions

Nominal Dimensions

bore code	d	D	B	C	A	dk	r	H	L
	0/-0.0005	±0.010	0/-0.002	±0.005	±0.031	≈	±0.005	UNJF-3A	±0.010
	0/-0.0127	±0.254	0/-0.051	±0.127	±0.79		±0.127		±0.254

in/mm

in/mm

03	0.1900 4,826	0.806 20,472	0.437 11,100	0.337 8,56	0.968 24,587	0.530 13,464	0.010 0,254	5/16-24 7,94-24	1.562 39,675
04	0.2500 6,350	0.806 20,472	0.437 11,100	0.337 8,56	0.968 24,587	0.530 13,464	0.010 0,254	5/16-24 7,94-24	1.562 39,675
05	0.3125 7,938	0.900 22,860	0.437 11,100	0.327 8,306	1.187 30,150	0.566 14,381	0.010 0,254	5/16-24 7,94-24	1.875 47,625
06	0.3750 9,525	1.025 26,035	0.500 12,700	0.416 10,566	1.187 30,150	0.683 17,361	0.010 0,254	3/8-24 9,52-24	1.938 49,225
07	0.4375 11,113	1.150 29,210	0.562 14,275	0.452 11,481	1.281 32,537	0.777 19,744	0.010 0,254	7/16-20 11,11-20	2.125 53,975
08	0.5000 12,700	1.337 33,960	0.625 15,875	0.515 13,081	1.468 37,287	0.871 22,130	0.010 0,254	1/2-20 12,7-20	2.438 61,925
10	0.6250 15,875	1.525 38,735	0.750 19,050	0.577 14,656	1.562 39,675	1.059 26,887	0.254 0,010	5/8-18 15,87-18	2.625 66,675
12	0.7500 19,050	1.775 45,085	0.875 22,225	0.640 16,256	1.687 42,850	1.216 30,897	0.010 0,254	3/4-16 19,05-16	2.875 73,025
14	0.8750 22,225	2.025 51,435	0.875 22,225	0.765 19,431	2.000 50,800	1.325 33,655	0.010 0,254	7/8-14 22,22-14	3.375 85,725
16	1.0000 25,400	2.775 70,485	1.375 34,925	1.015 25,781	2.343 59,512	1.871 47,526	0.010 0,254	1 1/4-12 31,75-12	4.125 104,775

¹) Parts are delivered and marked with PHUMJ/XRL.. or 12CM.. standard references

Cross-reference designation system to PHUMJ/XRL.. or 12CM..

Examples: EPHMJ/WAS04GK
PHMJ/WAS14

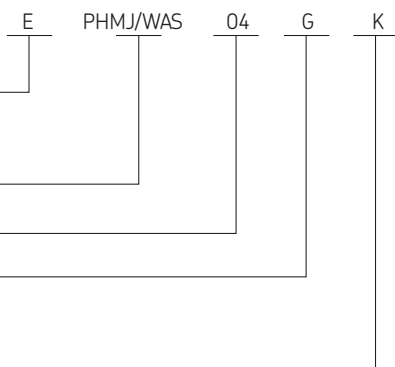

Inner ring material

No code 440C (WAS..R bearing)
E PH13.8 (EWAS..R.. bearing)

Basic designation

Bore code (multiples of 1/16 inch)

Thread direction

No code Right-hand thread
G Left-hand thread

Keyway

No code Without keyway
K With keyway

3.23



Dimensions cont., loads and torque

Nominal bore code	Dimensions				Mass ≈	Radial loads		Fatigue 50 000 cycles	Starting torque
	M	N	V	α		Ultimate			
	+0.005/0 +0,127/0	0/-0.005 0/-0,127	0/-0.020 0/-0,508						
–	in/mm			°	lb/g	lbf/kN		lbf-in/Nm	
03	0.062 1,575	0.268 6,807	0.980 24,892	15	0.072 33	2 360 10,50	1 470 6,54	0.5/6 0,056/0,678	
04	0.062 1,575	0.268 6,807	0.980 24,892	15	0.072 33	4 860 21,62	2 380 10,59	0.5/6 0,056/0,678	
05	0.062 1,575	0.268 6,807	1.270 32,258	14	0.087 39	7 180 31,95	2 770 12,32	1/15 0,113/1,695	
06	0.093 2,362	0.319 8,103	1.235 31,369	8	0.136 62	8 550 38,05	3 570 15,88	1/15 0,113/1,695	
07	0.093 2,362	0.383 9,728	1.402 35,611	10	0.188 83	12 000 53,4	4 800 21,35	1/15 0,113/1,695	
08	0.093 2,362	0.445 11,303	1.589 40,361	9	0.278 126	19 500 86,70	7 680 34,16	1/15 0,113/1,695	
10	0.125 3,175	0.541 13,741	1.683 42,748	12	0.424 192	21 900 97,45	9 180 40,83	1/15 0,113/1,695	
12	0.125 3,175	0.663 16,840	1.808 45,923	13	0.639 290	29 300 130,38	11 600 51,60	1/15 0,113/1,695	
14	0.156 3,962	0.777 19,736	2.121 53,873	6	0.963 437	34 500 153,52	13 100 58,27	1/24 0,113/2,712	
16	1.187 30,150	1.136 28,854	2.464 62,586	12	2.546 1 150	80 300 357,31	30 400 135,22	1/24 0,113/2,712	

3.24 External thread inserted narrow self-lubricating spherical plain bearing rod end (inch dimensions)

MJ/NAS.. (UMJ/XRE.. or 12BNM..)¹

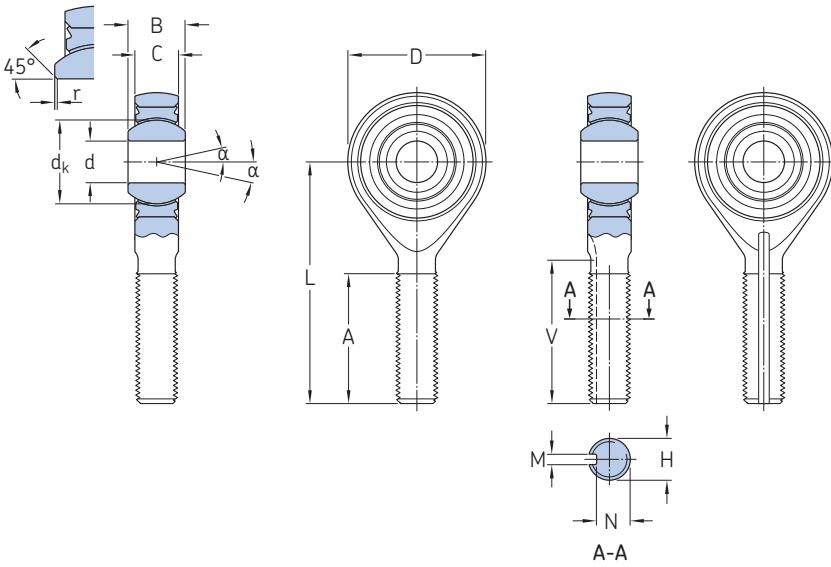

Technical specification	AS 81935
Product standard	AS 81935/4
Bearing	NAS..R inch (440C inner ring) ENAS..R inch (PH13.8 inner ring)

Dimensions

Nominal Dimensions

bore code	d	D	B	C	A	d_k	r	H	L
	0/-0.0005	±0.010	0/-0.002	±0.005	±0.031	≈	±0.005	UNJF-3A	±0.010
	0/-0.0127	±0.254	0/-0.051	±0.127	±0.79		±0.127		±0.254

– in/mm – in/mm

03	0.1900 4,826	0.680 17,272	0.281 7,137	0.228 5,791	0.775 19,685	0.406 10,312	0.010 0,254	1/4-28 6,35-28	1.315 33,401
03B	0.1900 4,826	0.680 17,272	0.281 7,137	0.228 5,791	0.775 19,685	0.406 10,312	0.010 0,254	1/4-28 6,35-28	1.315 33,401
04	0.2500 6,350	0.827 21,006	0.343 8,712	0.260 6,604	0.775 19,685	0.500 12,704	0.010 0,254	1/4-28 6,35-28	1.443 36,652
05	0.3125 7,938	0.984 24,994	0.375 9,525	0.291 7,391	1.187 30,150	0.562 14,283	0.010 0,254	5/16-24 7,94-24	1.948 49,479
06	0.3750 9,525	1.131 28,727	0.406 10,312	0.322 8,179	1.187 30,150	0.625 15,872	0.010 0,254	3/8-24 9,52-24	2.030 51,562
07	0.4375 11,113	1.294 32,868	0.437 11,100	0.353 8,966	1.281 32,537	0.687 17,448	0.010 0,254	7/16-20 11,11-20	2.250 57,150
08	0.5000 12,700	1.459 37,059	0.500 12,700	0.400 10,160	1.468 37,287	0.781 19,838	0.010 0,254	1/2-20 12,7-20	2.544 64,618
10	0.6250 15,875	1.763 44,780	0.625 15,875	0.510 12,954	1.562 39,675	0.978 24,584	0.010 0,254	5/8-18 15,87-18	2.832 71,933
12	0.7500 19,050	2.140 54,356	0.750 19,050	0.603 15,316	1.687 42,850	1.187 30,149	0.010 0,254	3/4-16 19,05-16	3.193 81,102
14	0.8750 22,225	2.372 60,249	0.875 22,225	0.713 18,110	2.000 50,800	1.314 33,370	0.010 0,254	7/8-14 22,22-14	3.677 93,396
16	1.0000 25,400	2.681 68,097	1.000 25,400	0.807 20,498	2.100 53,340	1.500 38,099	0.010 0,254	1-12 25,4-12	3.968 100,787

¹) Parts are delivered and marked with UMJ/XRE.. and 12BNM.. standard references

Cross-reference designation system to UMJ/XRE.. or 12BNM..

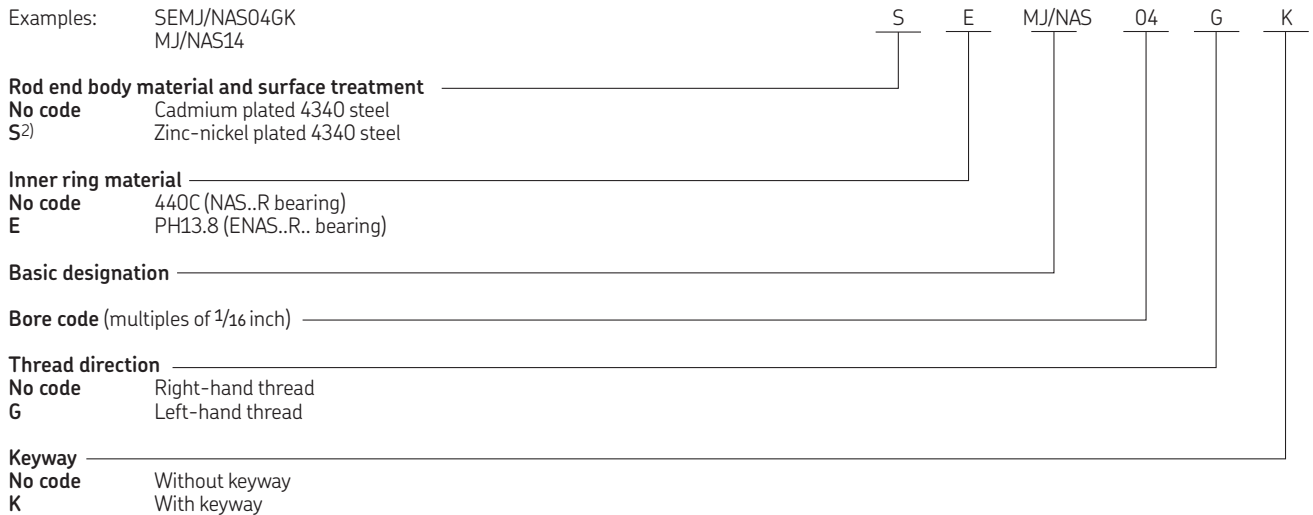

2) SKF option

Dimensions cont., loads and torque

Nominal bore code	Dimensions				α	Mass =	Radial loads		Starting torque
	M	N	V				Ultimate	Fatigue 50 000 cycles	
	+0,005/0 +0,127/0	0/-0,005 0/-0,127	Min	max					
–	in/mm				°	lb/g	lbf/kN		lbf-in/Nm
03	0.062 1,575	0.207 5,258	0.876 22,250	0.896 22,758	10	0.038 17	3 000 13,34	1 100 4,89	0.5/6 0,056/0,678
03B	0.062 1,575	0.207 5,258	0.836 21,234	0.876 22,250	10	0.038 17	3 000 13,34	1 100 4,89	0.5/6 0,056/0,678
04	0.062 1,575	0.207 2,258	0.876 22,250	0.896 22,758	10	0.045 20	5 300 23,6	1 500 6,67	0.5/6 0,056/0,678
05	0.062 1,575	0.268 6,807	1.288 32,715	1.308 33,223	10	0.081 37	8 600 38,25	2 400 10,67	1/15 0,113/1,695
06	0.093 2,362	0.319 8,103	1.288 32,715	1.308 33,223	9	0.120 54	13 000 57,82	3 600 16,01	1/15 0,113/1,695
07	0.093 2,362	0.383 9,728	1.382 35,103	1.402 35,611	8	0.172 78	17 800 79,17	5 000 22,24	1/15 0,113/1,695
08	0.093 2,362	0.445 11,303	1.569 39,853	1.589 40,361	8	0.254 115	24 200 107,64	6 800 30,25	1/15 0,113/1,695
10	0.125 3,175	0.541 13,741	1.663 42,240	1.683 42,748	8	0.455 206	38 500 171,25	10 800 48,04	1/15 0,113/1,695
12	0.125 3,175	0.663 16,840	1.788 45,415	1.808 45,923	8	0.774 351	56 600 251,76	16 000 71,17	1/15 0,113/1,695
14	0.156 3,962	0.777 19,736	2.101 53,365	2.121 53,873	8	1.141 518	77 400 344,27	21 900 97,41	1/24 0,113/2,712
16	0.156 3,962	0.900 22,860	2.201 55,905	2.221 56,413	9	1.646 747	101 400 451,03	28 600 127,21	1/24 0,113/2,712

3.25 External thread inserted narrow self-lubricating spherical plain bearing rod end (inch dimensions)

PHMJ/NAS.. (PHUMJ/XRE.. or 12CNM..)1)

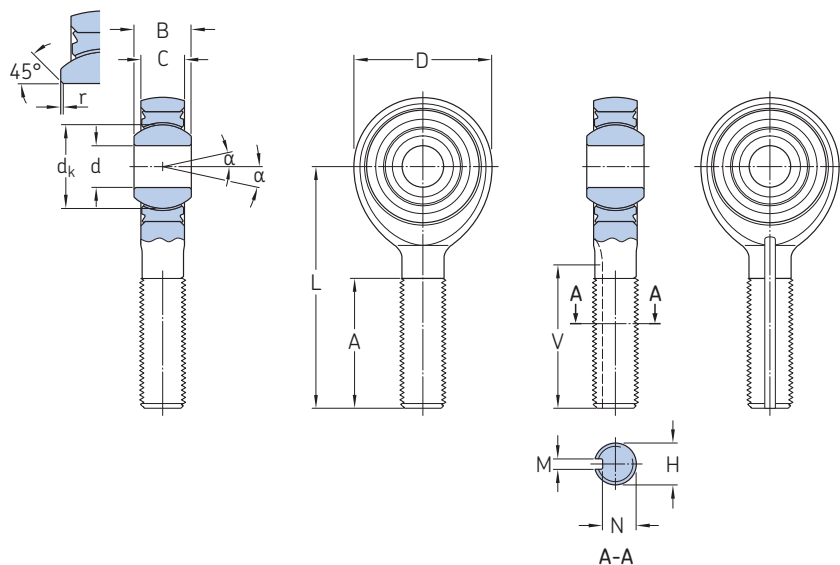

Technical specification	AS 81935
Product standard	AS 81935/8
Rod end material	PH13.8 passivated
Bearing	NAS..R inch (440C inner ring) ENAS..R inch (PH13.8 inner ring)

3.25

Dimensions

Nominal Dimensions

bore code	d	D	B	C	A	dk	r	H	L
	0/-0.0005	±0.010	0/-0.002	±0.005	±0.031	≈	±0.005	UNJF-3A	±0.010
	0/-0.0127	±0.254	0/-0.051	±0.127	±0.79		±0.127		±0.254

– in/mm

– in/mm

03	0.1900 4,826	0.680 17,272	0.281 7,137	0.228 5,791	0.775 19,685	0.406 10,312	0.010 0,254	1/4-28 6,35-28	1.315 33,401
04	0.2500 6,350	0.827 21,006	0.343 8,712	0.260 6,604	0.775 19,685	0.500 12,704	0.010 0,254	1/4-28 6,35-28	1.443 36,652
05	0.3125 7,938	0.984 24,994	0.375 9,525	0.291 7,391	1.187 30,150	0.562 14,283	0.010 0,254	5/16-24 7,94-24	1.948 49,479
06	0.3750 9,525	1.131 28,727	0.406 10,312	0.322 8,179	1.187 30,150	0.625 15,872	0.010 0,254	3/8-24 9,52-24	2.030 51,562
07	0.4375 11,113	1.294 32,868	0.437 11,100	0.353 8,966	1.281 32,537	0.687 17,448	0.010 0,254	7/16-20 11,11-20	2.250 57,150
08	0.5000 12,700	1.459 37,059	0.500 12,700	0.400 10,160	1.468 37,287	0.781 19,838	0.010 0,254	1/2-20 12,7-20	2.544 64,618
10	0.6250 15,875	1.763 44,780	0.625 15,875	0.510 12,954	1.562 39,675	0.968 24,584	0.010 0,254	5/8-18 15,87-18	2.832 71,933
12	0.7500 19,050	2.140 54,356	0.750 19,050	0.603 15,316	1.687 42,850	1.187 30,149	0.010 0,254	3/4-16 19,05-16	3.193 81,102
14	0.8750 22,225	2.372 60,249	0.875 22,225	0.713 18,110	2.000 50,800	1.314 33,370	0.010 0,254	7/8-14 22,22-14	3.677 93,396
16	1.0000 25,400	2.681 68,097	1.000 25,400	0.807 20,498	2.100 53,340	1.500 38,099	0.010 0,254	1-12 25,4-12	3.968 100,787

1) Parts are delivered and marked with PHUMJ/XRE.. or 12CNM.. standard references

Cross-reference designation system to PHUMJ/XRE.. or 12CNM..

Examples: EPHMJ/NAS03GK
PHMJ/NAS14

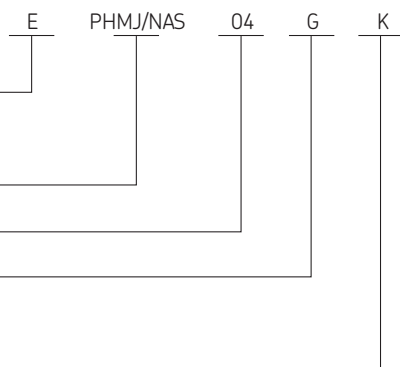

Inner ring material

No code 440C (NAS..R bearing)
E PH13.8 (ENAS..R.. bearing)

Basic designation

Bore code (multiples of 1/16 inch)

Thread direction

No code Right-hand thread
G Left-hand thread

Keyway

No code Without keyway
K With keyway

3.25



Dimensions cont., loads and torque

Nominal bore code	Dimensions				α	Mass =	Radial loads		Starting torque
	M	N	V				Ultimate	Fatigue	
	+0.005/0 +0,127/0	0/-0.005 0/-0,127	Min	max			50 000 cycles		
–	in/mm				°	lb/g	lbf/kN		lbf-in/Nm
03	0.062 1,575	0.207 5,258	0.836 21,234	0.896 22,758	10	0.038 17	3 000 13,34	1 100 4,89	0.5/6 0,056/0,678
04	0.062 1,575	0.207 2,258	0.876 22,250	0.896 22,758	10	0.045 20	5 300 23,6	1 500 6,67	0.5/6 0,056/0,678
05	0.062 1,575	0.268 6,807	1.288 32,715	1.308 33,223	10	0.081 37	8 600 38,25	2 400 10,67	1/15 0,113/1,695
06	0.093 2,362	0.319 8,103	1.288 32,715	1.308 33,223	9	0.120 54	13 000 57,82	3 600 16,01	1/15 0,113/1,695
07	0.093 2,362	0.383 9,728	1.382 35,103	1.402 35,611	8	0.172 78	17 800 79,17	5 000 22,24	1/15 0,113/1,695
08	0.093 2,362	0.445 11,303	1.569 39,853	1.589 40,361	8	0.254 115	24 200 107,64	6 800 30,25	1/15 0,113/1,695
10	0.125 3,175	0.541 13,741	1.663 42,240	1.683 42,748	8	0.455 206	38 500 171,25	10 800 48,04	1/15 0,113/1,695
12	0.125 3,175	0.663 16,840	1.788 45,415	1.808 45,923	8	0.774 351	56 600 251,76	16 000 71,17	1/15 0,113/1,695
14	0.156 3,962	0.777 19,736	2.101 53,365	2.121 53,873	8	1.141 518	77 400 344,27	21 900 97,41	1/24 0,113/2,712
16	0.156 3,962	0.900 22,860	2.201 55,905	2.221 56,413	9	1.646 747	101 400 451,03	28 600 127,21	1/24 0,113/2,712

3.26 External thread self-lubricating spherical plain bearing rod end (inch dimensions)

R..M..

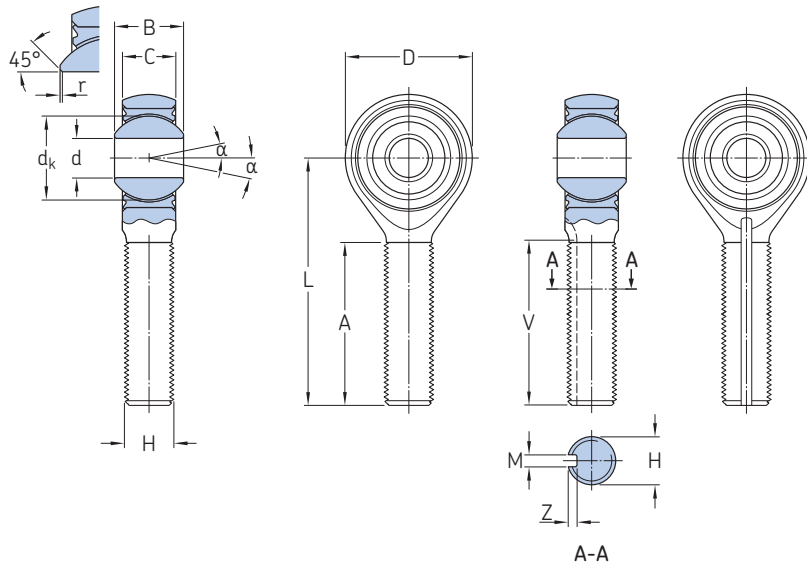

Technical specification	AS 81935
Product standard	NSA 8143
Liner	X1
Inner ring	Corrosion-resistant steel 440C
Outer ring	Corrosion-resistant steel 17-4PH H1150
Rod end body	Corrosion-resistant steel 17-4PH H1025
Bearing	SW..G inch

Dimensions

Nominal Dimensions

bore code	d	B	D	C	L	r	H	A	dk
	0/-0.0005 0/-0,0127	0/-0.002 0/-0,051	±0.010 ±0,254	±0.005 ±0,127	±0.010 ±0,254	+0.010/0 +0,254/0	UNJF-3A	+0.060/-0.030 +1,524/-0,762	≈
	in/mm							in/mm	
03	0.1900 4,826	0.437 11,100	0.806 20,472	0.337 8,560	1.562 39,675	0.005 0,127	5/16-24	1.000 25,400	0.531 13,487
04	0.2500 6,350	0.437 11,100	0.806 20,472	0.337 8,560	1.562 39,675	0.005 0,127	5/16-24	1.000 25,400	0.531 13,487
05	0.3125 7,938	0.437 11,100	0.900 22,860	0.327 8,306	1.875 47,625	0.005 0,127	5/16-24	1.062 26,974	0.593 15,062
051	0.3125 7,938	0.437 11,100	0.900 22,860	0.327 8,306	2.270 57,655	0.005 0,127	5/16-24	1.457 37,000	0.593 15,062
06	0.3750 9,525	0.500 12,700	1.025 26,035	0.416 10,566	1.938 49,225	0.005 0,127	3/16-24	1.250 31,750	0.687 17,449
061	0.3750 9,525	0.500 12,700	1.025 26,035	0.416 10,566	2.341 59,475	0.005 0,127	3/16-24	1.653 42,000	0.687 17,449
07	0.4375 11,113	0.562 14,274	1.150 29,210	0.452 11,481	2.125 53,975	0.005 0,127	7/16-20	1.375 34,925	0.781 19,837
08	0.5000 12,700	0.625 15,875	1.337 33,960	0.515 13,081	2.438 61,925	0.005 0,127	1/2-20	1.500 38,100	0.875 22,225
081	0.5000 12,700	0.625 15,875	1.337 33,960	0.515 13,081	3.044 77,325	0.005 0,127	1/2-20	2.126 54,000	0.875 22,225
10	0.6250 15,875	0.750 19,050	1.525 38,735	0.577 14,656	2.625 66,675	0.005 0,127	5/8-20	1.625 41,275	1.062 26,974
12	0.7500 19,050	0.875 22,225	1.775 45,085	0.640 16,256	2.875 73,025	0.005 0,127	3/4-16	1.750 44,450	1.250 31,750
14	0.8750 22,225	0.875 22,225	2.025 51,435	0.765 19,431	3.375 85,725	0.005 0,127	7/8-14	1.875 47,625	1.375 34,925
16	1.0000 25,400	1.375 34,925	2.775 70,485	1.015 25,781	4.125 104,775	0.005 0,127	1 1/4-12	2.123 53,915	1.937 49,200

Designation system

Examples: R03MLCK
R12MR

R 03 M L C K

Basic designation

Bore code (multiples of 1/16 inch)

Thread direction

R Right-hand thread
L Left-hand thread

Surface treatment of rod end body

No code No treatment
C¹⁾ Cadmium plated
J¹⁾ Zinc-nickel plated

Keyway

No code Without keyway
K With keyway

1) SKF option

Dimensions cont., loads and torque

Nominal bore code	Dimensions			α	Mass \approx	Radial loads Ultimate	Fatigue 50 000 cycles	Starting torque
	Z	M	V					
	+0,005/0 +0,127/0	+0,005/0 +0,127/0	+0,010/-0,030 +0,254/-0,762					
–	in/mm			°	lb/g	lbf/kN		lbf-in/Nm
03	0.052 1,320	0.062 1,575	0.920 23,368	17	0.06 27,21	4 800 21,35	1470.25 6,54	0.5/6 0,056/0,678
04	0.052 1,320	0.062 1,575	0.920 23,368	17	0.06 27,21	4 800 21,35	2380.73 10,59	0.5/6 0,056/0,678
05	0.052 1,320	0.062 1,575	0.980 24,892	14	0.07 31,75	5 500 24,47	2769.65 12,32	1/10 0,113/1,129
051	0.052 1,320	0.062 1,575	0.980 24,892	14	0.07 31,75	5 500 24,47	2769.65 12,32	1/10 0,113/1,129
06	0.064 1,625	0.093 2,362	1.170 29,718	10	0.11 49,89	7 000 31,14	3569.97 15,88	1/10 0,113/1,129
061	0.064 1,625	0.093 2,362	1.170 29,718	10	0.11 49,89	7 000 31,14	3569.97 15,88	1/10 0,113/1,129
07	0.067 1,701	0.093 2,362	1.275 32,385	12	0.15 68,03	8 100 36,03	4799.67 21,35	1/10 0,113/1,129
08	0.064 1,625	0.093 2,362	1.400 35,560	9	0.25 113,39	14 200 63,16	7679.48 34,16	1/10 0,113/1,129
081	0.064 1,625	0.093 2,362	1.400 35,560	9	0.25 113,39	14 200 63,16	7679.48 34,16	1/10 0,113/1,129
10	0.084 2,133	0.125 3,175	1.515 38,481	12	0.37 167,82	16 150 71,84	9178.95 40,83	1/10 0,113/1,129
12	0.087 2,209	0.125 3,175	1.625 41,275	14	0.58 263,08	21 000 93,41	11 600,14 51,60	1/10 0,113/1,129
14	0.098 2,489	0.156 3,962	1.730 43,942	7	0.79 358,33	26 000 115,65	13099.62 58,27	2/16 0,226/1,807
16	0.114 2,895	0.187 4,750	1.960 49,784	15	2.30 1 043,26	55 500 246,88	30400.92 135,23	2/16 0,226/1,807

3.27 External thread inserted wide self-lubricating spherical plain bearing rod end (inch dimensions)

EMJ/RL..R

Technical specification	AS 81820 for the bearing
Product standard	–
Bearing	WAS..R inch

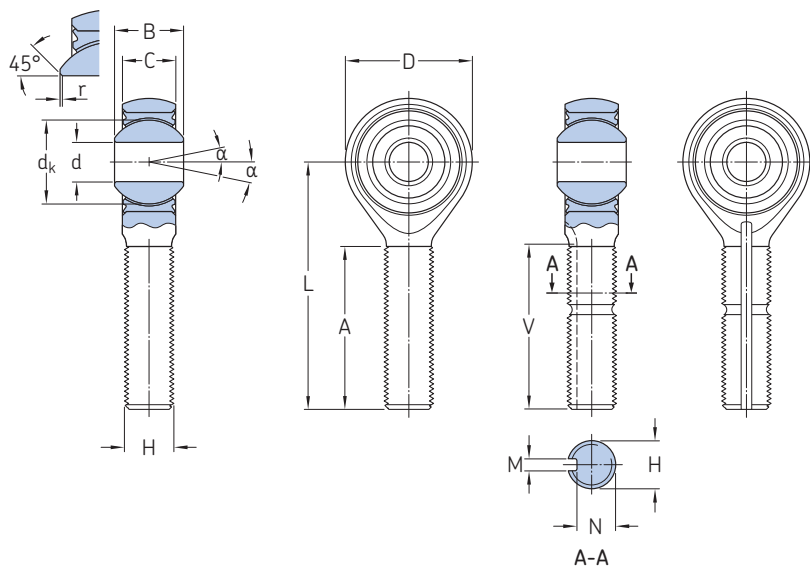

3.27

Dimensions

Nominal bore code	Dash number multiples of 1/16 inch	Dimensions								
		d	D	B	C	A	V	d _k	r	H
		0/-0.0005	±0.010	0/-0.002	±0.005	+0.06/-0.03	0/-0.020	d _k	±0.005	H
		0/-0.0127	±0.254	0/-0.051	±0.127	+1.524/-0.762	0/-0.508	≈	±0.127	UNJF-3A
		in/mm								
4,83	03	0.1900 4,826	0.806 20,472	0.437 11,100	0.337 8,56	1.000 25,400	1.000 25,400	0.530 13,464	0.010 0,254	5/16-24 7,94-24
6,35	04	0.2500 6,350	0.806 20,472	0.437 11,100	0.337 8,56	1.000 25,400	1.000 25,400	0.530 13,464	0.010 0,254	5/16-24 7,94-24
7,94	05	0.3125 7,938	0.900 22,860	0.437 11,100	0.327 8,306	1.062 26,975	1.062 26,975	0.566 14,381	0.010 0,254	5/16-24 7,94-24
9,52	06	0.3750 9,525	1.025 26,035	0.500 12,700	0.416 10,566	1.250 31,750	1.250 31,750	0.683 17,361	0.010 0,254	3/8-24 9,52-24
11,11	07	0.4375 11,113	1.150 29,210	0.562 14,275	0.452 11,481	1.375 34,925	1.375 34,925	0.777 19,744	0.010 0,254	7/16-20 11,11-20
12,7	08	0.5000 12,700	1.337 33,960	0.625 15,875	0.515 13,081	1.500 38,100	1.500 38,100	0.871 22,130	0.010 0,254	1/2-20 12,7-20
15,87	10	0.6250 15,875	1.525 38,735	0.750 19,050	0.577 14,656	1.625 41,275	1.625 41,275	1.059 26,887	0.010 0,254	5/8-18 15,87-18
19,05	12	0.7500 19,050	1.775 45,085	0.875 22,225	0.640 16,256	1.750 44,450	1.750 44,450	1.216 30,897	0.010 0,254	3/4-16 19,05-16
22,22	14	0.8750 22,225	2.025 51,435	0.875 22,225	0.765 19,431	1.875 47,625	1.875 47,625	1.325 33,655	0.010 0,254	7/8-14 22,22-14
25,4	16	1.0000 25,400	2.775 70,485	1.375 34,925	1.015 25,781	2.125 53,975	2.125 53,975	1.871 47,526	0.010 0,254	1 1/4-12 31,75-12

Designation system

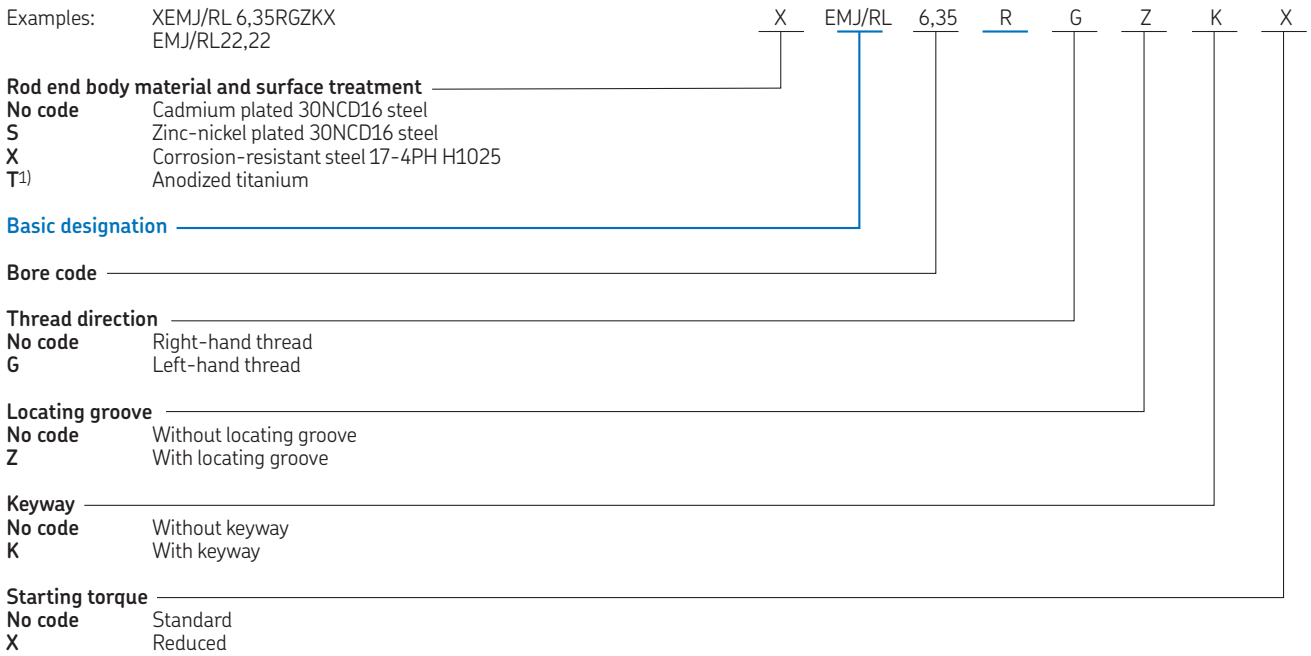

1) SKF option, masses and load carrying capability reduced compared to steel rod end body

Dimensions cont., loads and torque

Nominal bore code	Dash number multiples of 1/16 inch	Dimensions		N	α	Mass ≈	Radial loads		Starting torque	
		L ±0.010 ±0,254	M +0.005/0 +0,127/0				Ultimate ¹⁾	Fatigue 10 ⁶ cycles	Standard	Reduced
		in/mm			°	lb/g	lbf/kN	lbf-in/Nm		
4,83	03	1.562	0.062	0.260	16	0.07	6 195	1 052	0.53/10	1.1 max
		39,675	1,575	6,604		30	27,56	4,68	0,06/1,12	0,12 max
6,35	04	1.562	0.062	0.260	16	0.07	6 195	1 052	0.53/10	1.1 max
		39,675	1,575	6,604		30	27,56	4,68	0,06/1,12	0,12 max
7,94	05	1.875	0.062	0.260	15	0.08	7 585	1 090	1/10	2 max
		47,625	1,575	6,604		35	33,74	4,85	0,11/1,12	0,22 max
9,52	06	1.938	0.093	0.311	9	0.12	8 940	1 513	1/10	2 max
		49,225	2,362	7,900		55	39,77	6,73	0,11/1,12	0,22 max
11,11	07	2.125	0.093	0.370	11	0.17	9 595	1 920	1/10	2 max
		53,975	2,362	9,400		75	42,68	8,54	0,11/1,12	0,22 max
12,7	08	2.438	0.093	0.436	9	0.28	18 750	3 069	1/10	2 max
		61,925	2,362	11,074		127	83,40	13,65	0,11/1,12	0,22 max
15,87	10	2.625	0.125	0.541	12	0.38	20 680	3 480	1/10	2 max
		66,675	3,175	13,741		172	91,99	15,48	0,11/1,12	0,22 max
19,05	12	2.875	0.125	0.663	13	0.58	27 795	4 586	1/10	2 max
		73,025	3,175	16,840		263	123,64	20,40	0,11/1,12	0,22 max
22,22	14	3.375	0.156	0.777	6	0.81	31 725	5 348	2/15.9	4.1 max
		85,725	3,962	19,735		370	141,12	23,79	0,23/1,8	0,46 max
25,4	16	4.125	0.187	1.136	12	2.40	71 745	11 990	2/15.9	4.1 max
		104,775	4,750	28,854		1 100	319,14	53,33	0,23/1,8	0,46 max

1) Loads are valid for rod end bodies made of alloy steel or corrosion resistant steel. For other rod ends, refer to page 292

3.28 External thread inserted self-lubricating spherical plain bearing rod end (inch dimensions)

EMJ/RT..R

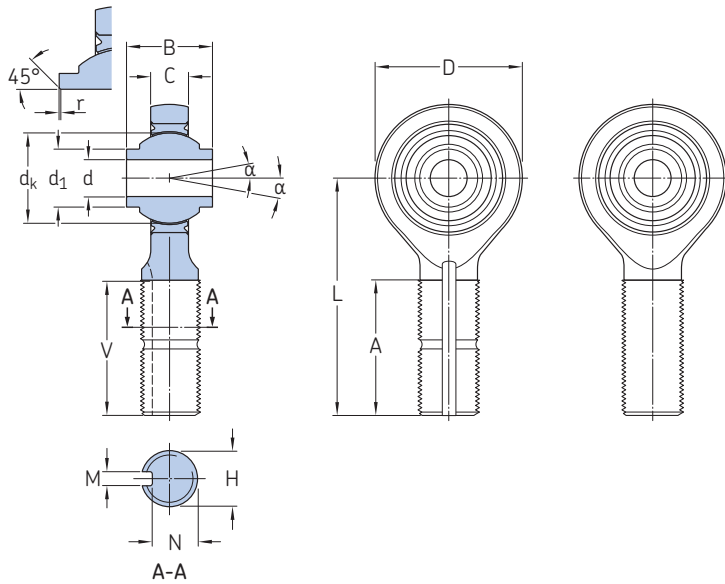

Technical specification	-
Product standard	-
Bearing	XRT..R inch

3.28

Dimensions

Nominal bore code	Dash number multiples of 1/16 inch	Dimensions									
		d	D	B	C	A	V	d _k	d ₁	r	H
		0/-0.0005 0/-0,0127	+0.035/-0.010 +0,889/-0,254	0/-0.005 0/-0,127	±0.005 ±0,127	+0.06/-0.03 +1,524/-0,762	0/-0.020 0/-0,508	≈	≈	+0.012/0 +0,3/0	H UNJF-3A
		in/mm									
4,83	03	0.1900 4,826	0.750 19,050	0.500 12,700	0.220 5,588	1.000 25,400	1.000 25,400	0.437 11,100	0.315 8,001	0.004 0,100	5/16-24 7,94-24
6,35	04	0.2500 6,350	1.000 25,400	0.593 15,062	0.265 6,731	1.250 31,750	1.250 31,750	0.594 15,080	0.386 9,804	0.004 0,100	3/8-24 9,52-24
7,94	05	0.3125 7,938	1.125 28,575	0.813 20,650	0.355 9,017	1.375 34,925	1.375 34,925	0.781 19,838	0.512 13,005	0.004 0,100	7/16-20 11,11-20
9,52	06	0.3750 9,525	1.125 28,575	0.813 20,650	0.355 9,017	1.375 34,925	1.375 34,925	0.781 19,838	0.532 13,513	0.004 0,100	7/16-20 11,11-20
11,11	07	0.4375 11,113	1.312 33,325	0.875 22,225	0.355 9,017	1.500 38,100	1.500 38,100	0.866 22,000	0.620 15,748	0.004 0,100	1/2-20 12,7-20
12,7	08	0.5000 12,700	1.500 38,100	0.937 23,799	0.411 10,439	1.625 41,275	1.625 41,275	0.984 25,000	0.728 18,491	0.004 0,100	5/8-18 15,87-18
15,87	10	0.6250 15,875	1.750 44,450	1.200 30,480	0.577 14,656	1.750 44,45	1.750 44,45	1.240 31,500	0.857 21,768	0.004 0,100	3/4-16 19,05-16
19,05	12	0.7500 19,050	2.000 50,800	1.280 32,512	0.630 16,002	1.875 47,625	1.875 47,625	1.339 34,000	0.963 24,460	0.004 0,100	7/8-14 22,22-14
22,22	14	0.8750 22,225	2.200 55,880	1.400 35,560	0.635 16,129	2.000 50,800	2.000 50,800	1.531 38,887	1.122 28,500	0.004 0,100	7/8-14 22,22-14
25,4	16	1.0000 25,400	2.750 69,850	1.875 47,625	0.845 21,463	2.125 53,975	2.125 53,975	1.875 47,625	1.272 32,309	0.004 0,100	1 1/4-12 31,75-12

Designation system

Examples: XEMJ/RT 6,35RGZKX
EMJ/RT11,11R

Rod end body material and surface treatment

No code Cadmium plated 30NCD16 steel
S Zinc-nickel plated 30NCD16 steel
X Corrosion-resistant steel 17-4PH H1025
T¹⁾ Anodized titanium

Basic designation

Bore code

Thread direction

No code Right-hand thread
G Left-hand thread

Locating groove

No code Without locating groove
Z With locating groove

Keyway

No code Without keyway
K With keyway

Starting torque

No code Standard
X Reduced

¹⁾ SKF option, masses and load carrying capability reduced compared to steel rod end body

Dimensions cont., loads and torque

Nominal bore code	Dash number multiples of 1/16 inch	Dimensions		N	α	Mass =	Radial loads		Starting torque	
		L $\pm 0,010$ $\pm 0,254$	M $+0,005/0$ $+0,127/0$				Ultimate ¹⁾	Fatigue 10 ⁶ cycles	Standard	Reduced
		in/mm			°	lb/g	lbf/kN	lbf-in/Nm		
4,83	03	1.500 38,100	0.062 1,575	0.260 6,604	15	0.06 27	4 800 21,35	762 3,39	0.53/5 0,06/0,56	1 max 0,12 max
6,35	04	1.938 49,225	0.093 2,362	0.311 7,899	24	0.11 50	8 185 36,41	1 311 5,83	0.53/5 0,06/0,56	1 max 0,12 max
7,94	05	2.125 53,975	0.093 2,362	0.370 9,400	23	0.16 73	8 620 38,34	1 414 6,29	0.7/7 0,08/0,8	2 max 0,22 max
9,52	06	2.125 53,975	0.093 2,362	0.370 9,400	22	0.16 73	8 620 38,34	1 414 6,29	0.88/9 0,10/1,02	2 max 0,22 max
11,11	07	2.438 61,925	0.093 2,362	0.436 11,074	22	0.25 114	13 025 57,94	2 104 9,36	0.88/9 0,10/1,02	2 max 0,22 max
12,7	08	2.625 66,675	0.125 3,175	0.541 13,741	20	0.41 186	18 165 80,80	2 947 13,11	0.88/9 0,10/1,02	2 max 0,22 max
15,87	10	2.875 73,025	0.125 3,175	0.663 16,840	20	0.64 290	24 010 106,80	3 973 17,67	1/12,4 0,11/1,4	2 max 0,22 max
19,05	12	3.375 85,725	0.156 3,962	0.777 19,735	19	0.92 417	26 990 120,06	5 052 22,47	1/12,4 0,11/1,4	2 max 0,22 max
22,22	14	3.750 95,250	0.156 3,962	0.777 19,735	19	1.11 508	28 880 128,46	5 295 23,55	2.21/18 0,25/2,04	4 max 0,46 max
25,4	16	4.125 104,775	0.187 4,750	1.136 28,854	21	2.14 970	60 230 267,92	9 858 43,85	2.21/18 0,25/2,04	4 max 0,46 max

¹⁾ Loads are valid for rod end bodies made of alloy steel or corrosion resistant steel. For other rod ends, refer to page 292

3.29 Internal thread inserted wide self-lubricating spherical plain bearing rod end (inch dimensions)

FJ/WAS.. (UFJ/XRL.. or 12BF..) bore code **03** to **07**

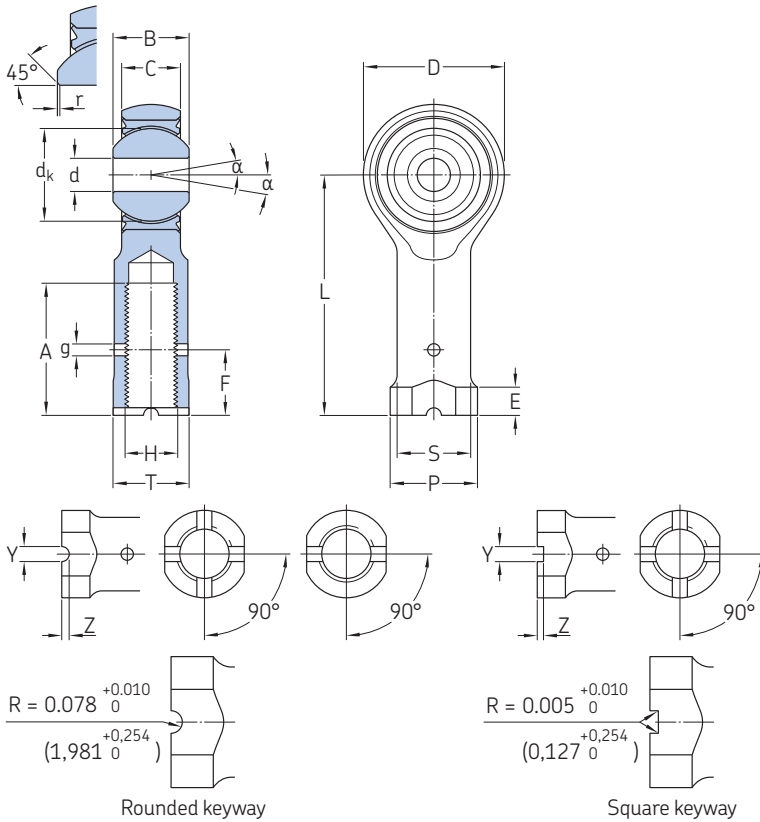

Technical specification	AS 81935
Product standard	AS 81935/2
Bearing	WAS..R inch (440C inner ring) EWAS..R inch (PH13.8 inner ring)

Keyway type	Bore code	Keyway shape	Number of slots
K	≤ 06	Rounded	2
	07 to 08	Rounded	4
	≥ 10	Square	4
W	All	Square	4

Dimensions

Nominal bore code	Dimensions							
	d	D	B	C	A	dk	r	H
	0/-0,0005	±0,010	0/-0,002	±0,005	Min	≈	±0,005	UNJF-3B
	0/-0,0127	±0,254	0/-0,051	±0,127			±0,127	

in/mm

03	0.1900 4,826	0.806 20,472	0.437 11,100	0.337 8,56	0.750 19,050	0.530 13,464	0.010 0,254	5/16-24 7,94-24
04	0.2500 6,350	0.806 20,472	0.437 11,100	0.337 8,56	0.750 19,050	0.530 13,464	0.010 0,254	5/16-24 7,94-24
05	0.3125 7,938	0.900 22,860	0.437 11,100	0.327 8,306	0.875 22,225	0.566 14,381	0.010 0,254	3/8-24 9,52-24
06	0.3750 9,525	1.025 26,035	0.500 12,700	0.416 10,566	1.000 25,400	0.683 17,361	0.010 0,254	3/8-24 9,52-24
07	0.4375 11,113	1.150 29,210	0.562 14,275	0.452 11,481	1.125 28,575	0.777 19,744	0.010 0,254	7/16-20 11,11-20

Dimensions cont.

Nominal bore code	Dimensions								
	g	L	P	F	S	T	E	Z ²⁾	Y ²⁾
	≈	±0,010	≈	±0,020	±0,010	+0,002/-0,010	+0,010/-0,062	+0,005/0	+0,005/0
		±0,254		±0,508	±0,254	+0,051/-0,254	+0,254/-1,575	+0,127/0	+0,127/0

in/mm

03	0.07 1,778	1.375 34,925	0.500 12,700	0.375 9,525	0.422 10,719	0.437 11,100	0.188 4,775	-	-
04	0.07 1,778	1.469 37,313	0.500 12,700	0.375 9,525	0.422 10,719	0.437 11,100	0.188 4,775	-	-
05	0.07 1,778	1.625 41,275	0.580 14,732	0.437 11,100	0.485 12,319	0.500 12,700	0.250 6,350	-	-
06	0.07 1,778	1.812 46,025	0.660 16,764	0.437 11,100	0.547 13,894	0.562 14,275	0.250 6,350	-	-
07	0.07 1,778	2.000 50,800	0.720 18,288	0.500 12,687	0.610 15,494	0.625 15,875	0.250 6,350	-	-

1) Parts are delivered and marked with UFJ/XRL.. and 12BF.. standard references

2) K version

Cross-reference designation system to UFJ/XRL.. or 12BF..

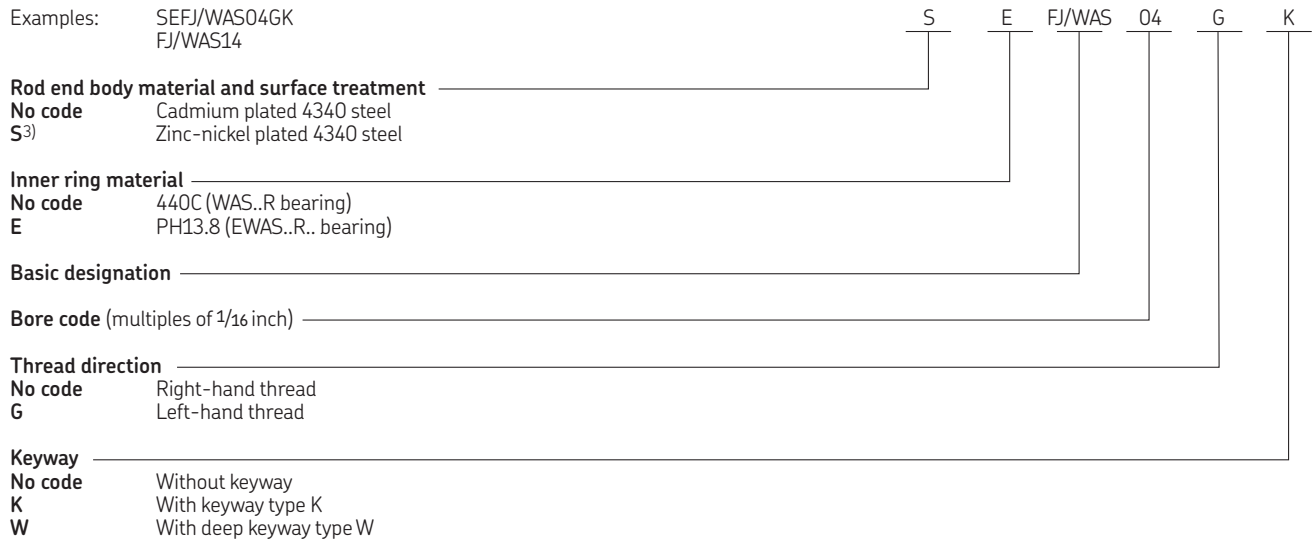

³⁾ SKF option

3.29



Dimensions cont., loads and torque

Nominal bore code	Dimensions Z ⁴⁾		α	Mass ≈	Radial loads Ultimate	Fatigue 50 000 cycles	Starting torque
	+0,005/0 +0,127/0	Y ⁴⁾ +0,005/0 +0,127/0					
–	in/mm		°	lb/g	lbf/kN		lbf-in/Nm
03	0.110 2,794	0.062 1,575	15	0.080 36	2 360 10,50	1 470 6,54	0.5/6 0,056/0,678
04	0.110 2,794	0.062 1,575	15	0.084 38	4 860 21,62	2 380 10,59	0.5/6 0,056/0,678
05	0.110 2,794	0.093 2,362	14	0.102 46	7 180 31,95	3 020 13,43	1/15 0,113/1,695
06	0.110 2,794	0.093 2,362	8	0.161 73	8 550 38,05	3 570 15,88	1/15 0,113/1,695
07	0.110 2,794	0.093 2,362	10	0.212 96	12 000 53,40	4 800 21,35	1/15 0,113/1,695

⁴⁾ W version

3.29 Internal inserted wide self-lubricating spherical plain bearing rod end (inch dimensions)

FJ/WAS.. (UFJ/XRL.. or 12BF..) bore code **08 to 16**

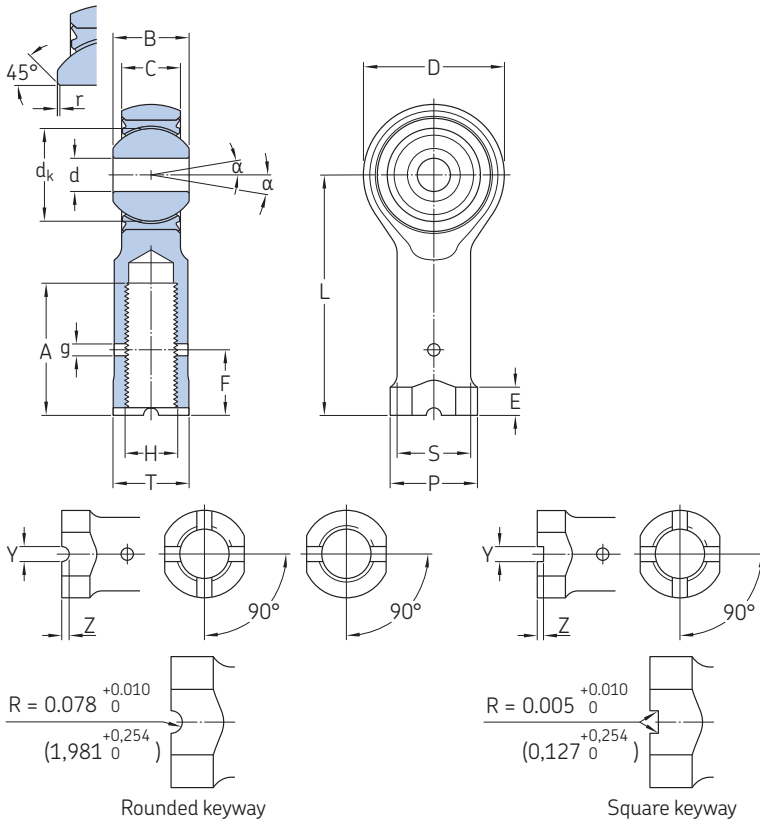

Technical specification	AS 81935
Product standard	AS 81935/2
Bearing	WAS..R inch (440C inner ring) EWAS..R inch (PH13.8 inner ring)

Keyway type	Bore code	Keyway shape	Number of slots
K	≤ 06	Rounded	2
	07 to 08	Rounded	4
	≥ 10	Square	4
W	All	Square	4

Dimensions

Nominal bore code	Dimensions							
	d	D	B	C	A	d _k	r	H
	0/-0.0005 0/-0,0127	±0.010 ±0,254	0/-0.002 0/-0,051	±0.005 ±0,127	Min	≈	±0.005 ±0,127	UNJF-3B
-	in/mm							
08	0.5000 12,700	1.337 33,960	0.625 15,875	0.515 13,081	1.250 31,750	0.871 22,130	0.010 0,254	1/2-20 12,7-20
10	0.6250 15,875	1.525 38,735	0.750 19,050	0.577 14,656	1.375 34,925	1.059 26,887	0.254 0,010	5/8-18 15,87-18
12	0.7500 19,050	1.775 45,085	0.875 22,225	0.640 16,256	1.625 41,275	1.216 30,897	0.010 0,254	3/4-16 19,05-16
14	0.8750 22,225	2.025 51,435	0.875 22,225	0.765 19,431	1.875 47,625	1.325 33,655	0.010 0,254	7/8-14 22,22-14
16	1.0000 25,400	2.775 70,485	1.375 34,925	1.015 25,781	2.125 53,975	1.871 47,526	0.010 0,254	1 1/4-12 31,75-12

Dimensions cont.

Nominal bore code	Dimensions								
	g	L	P	F	S	T	E	Z ²⁾	Y ²⁾
	≈	±0.010 ±0,254	≈	±0.020 ±0,508	±0.010 ±0,254	+0.002/-0.010 +0,051/-0,254	+0.010/-0.062 +0,254/-1,575	+0.005/0 +0,127/0	+0.005/0 +0,127/0
-	in/mm								
08	0.07 1,778	2.250 57,150	0.880 22,352	0.562 14,275	0.735 18,669	0.750 19,050	0.250 6,350	-	-
10	0.07 1,778	2.500 63,500	1.020 25,908	0.687 17,450	0.860 21,844	0.875 22,225	0.375 9,525	0.077 1,956	0.125 3,175
12	0.07 1,778	2.875 73,025	1.160 29,464	0.812 20,625	0.985 25,019	1.000 25,400	0.375 9,525	0.077 1,956	0.125 3,175
14	0.07 1,778	3.375 85,725	1.300 33,020	0.937 23,800	1.110 28,194	1.125 28,575	0.500 12,700	0.086 2,184	0.156 3,962
16	0.07 1,778	4.125 104,775	2.020 51,308	1.312 33,325	1.688 42,875	1.750 44,450	0.563 14,300	0.116 2,946	0.187 4,750

1) Parts are delivered and marked with UFJ/XRL.. and 12BF.. standard references

2) K version

Cross-reference designation system to UFJ/XRL.. or 12BF..

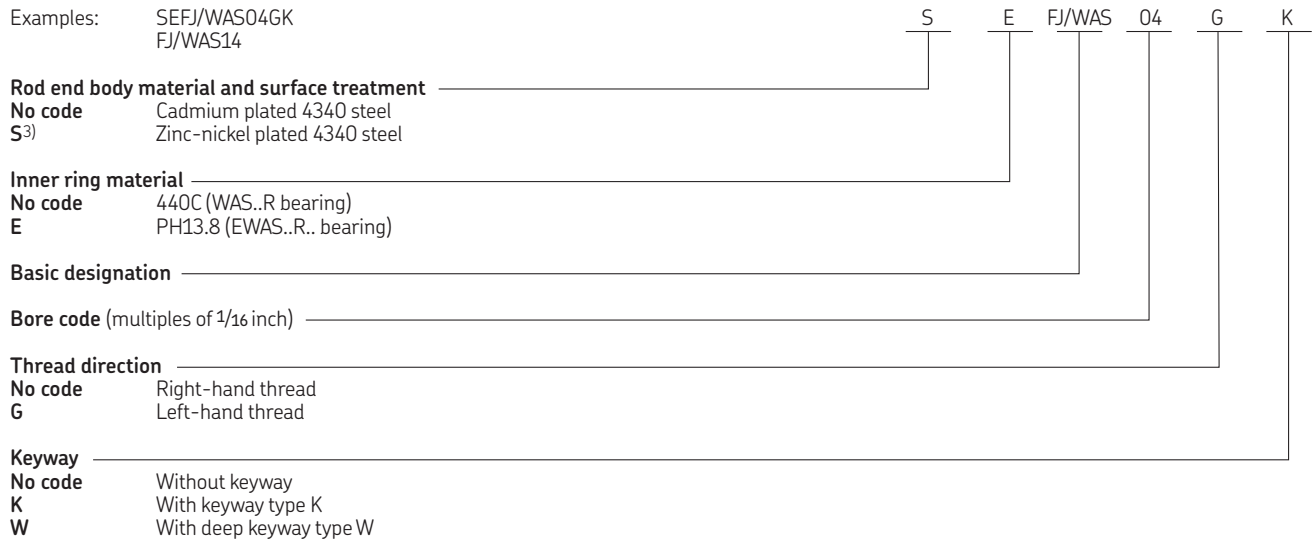

³⁾ SKF option

3.29



Dimensions cont., loads and torque

Nominal bore code	Dimensions		α	Mass \approx	Radial loads		Starting torque
	Z ⁴⁾	Y ⁴⁾			Ultimate	Fatigue	
	+0,005/0 +0,127/0	+0,005/0 +0,127/0				50 000 cycles	
–	in/mm		°	lb/g	lbf/kN		lbf-in/Nm
08	0.110 2,794	0.093 2,362	9	0.325 147	19 500 86,70	8 260 36,74	1/15 0.113/1.695
10	0.110 2,794	0.125 3,175	12	0.481 218	21 900 97,45	9 180 40,83	1/15 0.113/1.695
12	0.110 2,794	0.125 3,175	13	0.673 305	29 300 130,38	11 600 51,60	1/15 0.113/1.695
14	0.110 2,794	0.156 3,962	6	0.959 435	34 500 153,52	13 100 58,27	1/24 0.113/2.712
16	0.116 2,946	0.187 4,750	12	2.717 1 232	80 300 357,31	30 400 135,22	1/24 0.113/2.712

⁴⁾ W version

3.30 Internal thread inserted wide self-lubricating spherical plain bearing rod end (inch dimensions)

PHUFJ/WAS.. (PHUFJ/XRL.. or 12CF..) bore code 03 to 07

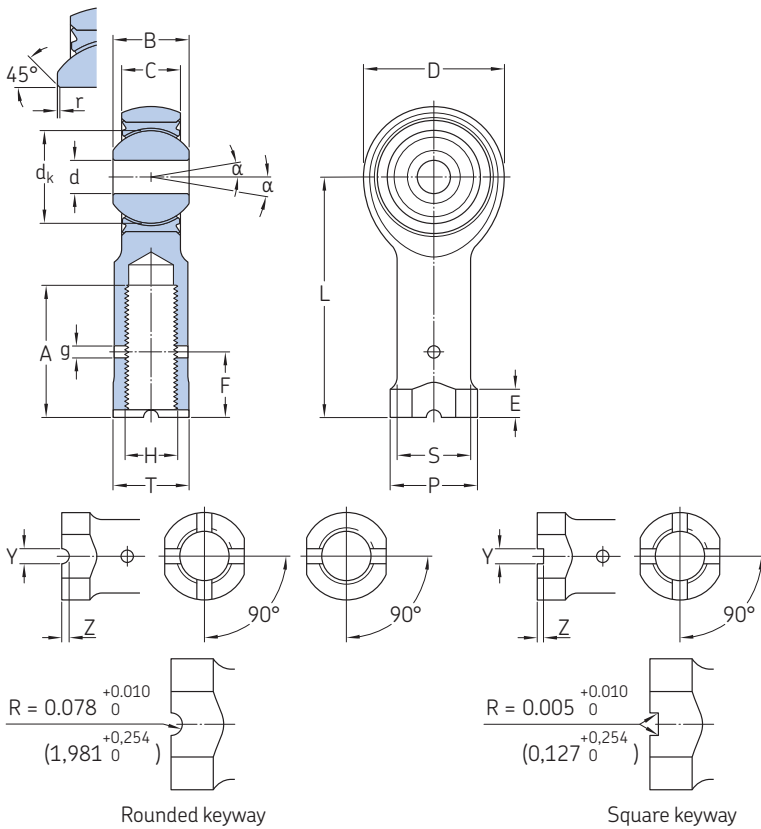

Technical specification	AS 81935
Product standard	AS 81935/7
Rod end body	PH13.8 passivated
Bearing	WAS..R inch (440C inner ring) EWAS..R inch (PH13.8 inner ring)

Keyway type	Bore code	Keyway shape	Number of slots
K	≤ 06	Rounded	2
	07 to 08	Rounded	4
	≥ 10	Square	4
W	All	Square	4

3.30

Dimensions

Nominal bore code	Dimensions							
	d	D	B	C	A	d _k	r	H
	0/-0.0005 0/-0,0127	±0.010 ±0,254	0/-0.002 0/-0,051	±0.005 ±0,127	Min	≈	±0.005 ±0,127	UNJF-3B
- in/mm								
03	0.1900 4,826	0.806 20,472	0.437 11,100	0.337 8,56	0.750 19,050	0.530 13,464	0.010 0,254	5/16-24 7,94-24
04	0.2500 6,350	0.806 20,472	0.437 11,100	0.337 8,56	0.750 19,050	0.530 13,464	0.010 0,254	5/16-24 7,94-24
05	0.3125 7,938	0.900 22,860	0.437 11,100	0.327 8,306	0.875 22,225	0.566 14,381	0.010 0,254	3/8-24 9,52-24
06	0.3750 9,525	1.025 26,035	0.500 12,700	0.416 10,566	1.000 25,400	0.683 17,361	0.010 0,254	3/8-24 9,52-24
07	0.4375 11,113	1.150 29,210	0.562 14,275	0.452 11,481	1.125 28,575	0.777 19,744	0.010 0,254	7/16-20 11,11-20

Dimensions cont.

Nominal bore code	Dimensions								
	g	L	P	F	S	T	E	Z ²⁾	Y ²⁾
	≈	±0.010 ±0,254	≈	±0.020 ±0,508	±0.010 ±0,254	+0.002/-0.010 +0,051/-0,254	+0.010/-0.062 +0,254/-1,575	+0.005/0 +0,127/0	+0.005/0 +0,127/0
- in/mm									
03	0.07 1,778	1.375 34,925	0.500 12,700	0.375 9,525	0.422 10,719	0.437 11,100	0.188 4,775	-	-
04	0.07 1,778	1.469 37,313	0.500 12,700	0.375 9,525	0.422 10,719	0.437 11,100	0.188 4,775	-	-
05	0.07 1,778	1.625 41,275	0.580 14,732	0.437 11,100	0.485 12,319	0.500 12,700	0.250 6,350	-	-
06	0.07 1,778	1.812 46,025	0.660 16,764	0.437 11,100	0.547 13,894	0.562 14,275	0.250 6,350	-	-
07	0.07 1,778	2.000 50,800	0.720 18,288	0.500 12,687	0.610 15,494	0.625 15,875	0.250 6,350	-	-

1) Parts are delivered and marked with PHUFJ/XRL.. or 12CF.. standard references

2) K version

Cross-reference designation system to PHUFJ/XRL.. or 12CF..

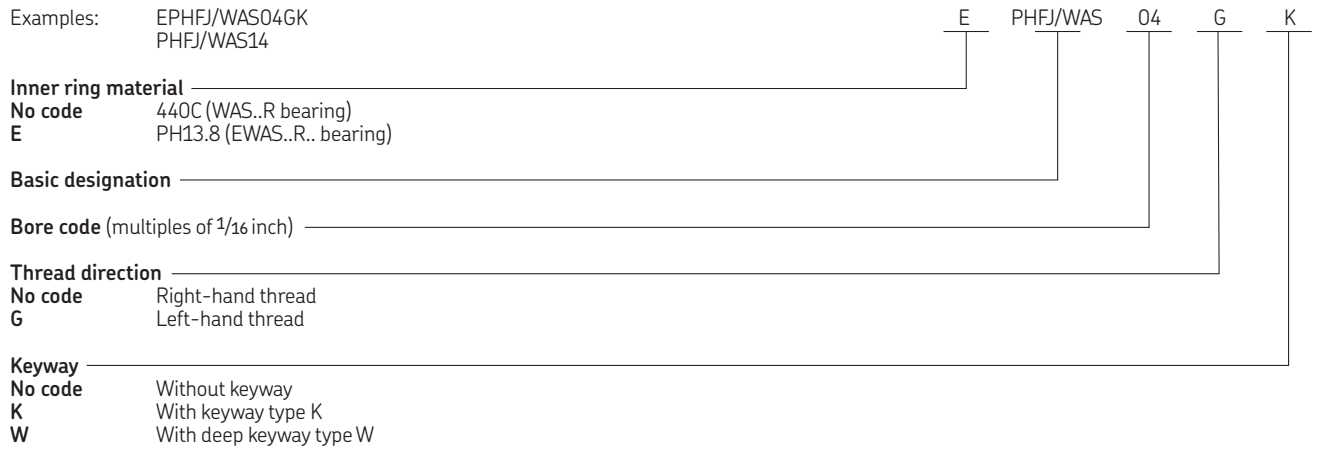

3.30



Dimensions cont., loads and torque

Nominal bore code	Dimensions		α	Mass \approx	Radial loads Ultimate	Fatigue 50 000 cycles	Starting torque
	Z ²⁾	Y ²⁾					
	+0,005/0 +0,127/0	+0,005/0 +0,127/0					
–	in/mm		°	lb/g	lbf/kN		lbf-in/Nm
03	0.110 2,794	0.062 1,575	15	0.080 36	2 360 10,50	1 470 6,54	0.5/6 0,056/0,678
04	0.110 2,794	0.062 1,575	15	0.084 38	4 860 21,62	2 380 10,59	0.5/6 0,056/0,678
05	0.110 2,794	0.093 2,362	14	0.102 46	7 180 31,95	3 020 13,43	1/15 0,113/1,695
06	0.110 2,794	0.093 2,362	8	0.161 73	8 550 38,05	3 570 15,88	1/15 0,113/1,695
07	0.110 2,794	0.093 2,362	10	0.212 96	12 000 53,40	4 800 21,35	1/15 0,113/1,695

²⁾ W version

3.30 Internal thread inserted wide self-lubricating spherical plain bearing rod end (inch dimensions)

PHFJ/WAS.. (PHUFJ/XRL.. or 12CF..) bore code **08 to 16**

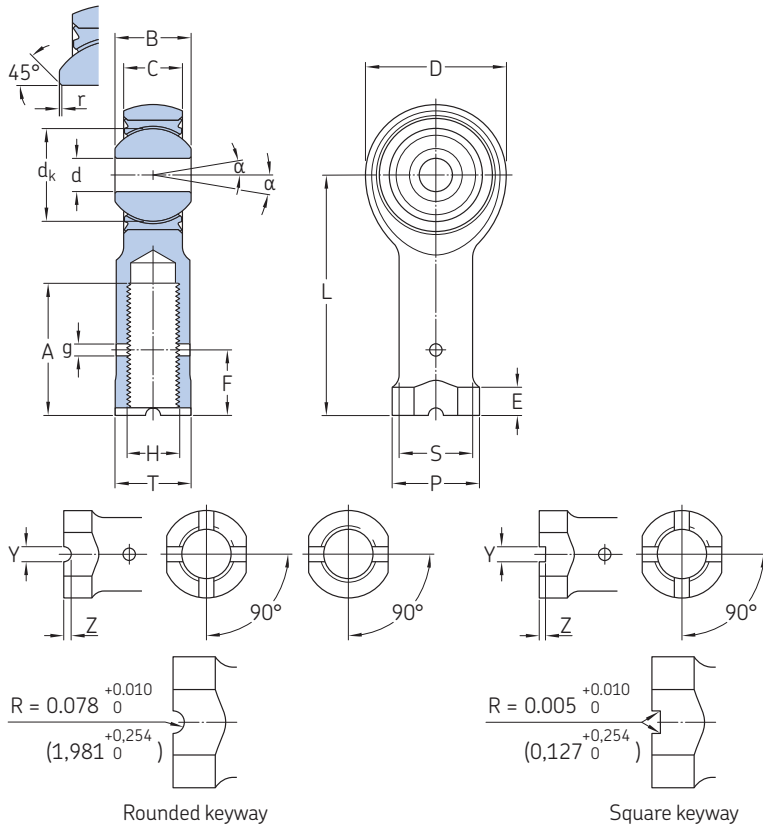

Technical specification	AS 81935
Product standard	AS 81935/7
Rod end body	PH13.8 passivated
Bearing	WAS..R inch (440C inner ring) EWAS..R inch (PH13.8 inner ring)

Keyway type	Bore code	Keyway shape	Number of slots
K	≤ 06	Rounded	2
	07 to 08	Rounded	4
W	≥ 10	Square	4
	All	Square	4

3.30

Dimensions

Nominal bore code	Dimensions							
	d	D	B	C	A	dk	r	H
	0/-0.0005 0/-0,0127	±0.010 ±0,254	0/-0.002 0/-0,051	±0.005 ±0,127	Min	≈	±0.005 ±0,127	UNJF-3B
-	in/mm							
08	0.5000 12,700	1.337 33,960	0.625 15,875	0.515 13,081	1.250 31,750	0.871 22,130	0.010 0,254	1/2-20 12,7-20
10	0.6250 15,875	1.525 38,735	0.750 19,050	0.577 14,656	1.375 34,925	1.059 26,887	0.254 0,010	5/8-18 15,87-18
12	0.7500 19,050	1.775 45,085	0.875 22,225	0.640 16,256	1.625 41,275	1.216 30,897	0.010 0,254	3/4-16 19,05-16
14	0.8750 22,225	2.025 51,435	0.875 22,225	0.765 19,431	1.875 47,625	1.325 33,655	0.010 0,254	7/8-14 22,22-14
16	1.0000 25,400	2.775 70,485	1.375 34,925	1.015 25,781	2.125 53,975	1.871 47,526	0.010 0,254	1 1/4-12 31,75-12

Dimensions cont.

Nominal bore code	Dimensions								
	g	L	P	F	S	T	E	Z ²⁾	Y ¹⁾
	≈	±0.010 ±0,254	≈	±0.020 ±0,508	±0.010 ±0,254	+0.002/-0.010 +0,051/-0,254	+0.010/-0.062 +0,254/-1,575	+0.005/0 +0,127/0	+0.005/0 +0,127/0
-	in/mm								
08	0.07 1,778	2.250 57,150	0.880 22,352	0.562 14,275	0.735 18,669	0.750 19,050	0.250 6,350	- -	- -
10	0.07 1,778	2.500 63,500	1.020 25,908	0.687 17,450	0.860 21,844	0.875 22,225	0.375 9,525	0.077 1,956	0.125 3,175
12	0.07 1,778	2.875 73,025	1.160 29,464	0.812 20,625	0.985 25,019	1.000 25,400	0.375 9,525	0.077 1,956	0.125 3,175
14	0.07 1,778	3.375 85,725	1.300 33,020	0.937 23,800	1.110 28,194	1.125 28,575	0.500 12,700	0.086 2,184	0.156 3,962
16	0.07 1,778	4.125 104,775	2.020 51,308	1.312 33,325	1.688 42,875	1.750 44,450	0.563 14,300	0.116 2,946	0.187 4,750

¹⁾ Parts are delivered and marked with PHUFJ/XRL.. or 12CF.. standard references

²⁾ K version

Cross-reference designation system to PHUFJ/XRL.. or 12CF..



3.30



Dimensions cont., loads and torque

Nominal bore code	Dimensions		α	Mass \approx	Radial loads Ultimate	Fatigue 50 000 cycles	Starting torque
	Z ²⁾	Y ²⁾					
–	+0,005/0 +0,127/0	+0,005/0 +0,127/0	°	lb/g	lbf/kN		lbf-in/Nm
08	0.110 2,794	0.093 2,362	9	0.325 147	19 500 86,70	8 260 36,74	1/15 0,113/1,695
10	0.110 2,794	0.125 3,175	12	0.481 218	21 900 97,45	9 180 40,83	1/15 0,113/1,695
12	0.110 2,794	0.125 3,175	13	0.673 305	29 300 130,38	11 600 51,60	1/15 0,113/1,695
14	0.110 2,794	0.156 3,962	6	0.959 435	34 500 153,52	13 100 58,27	1/24 0,113/2,712
16	0.116 2,946	0.187 4,750	12	2.717 1 232	80 300 357,31	30 400 135,22	1/24 0,113/2,712

²⁾ W version

3.31 Internal thread inserted narrow self-lubricating spherical plain bearing rod end (inch dimensions)

FJ/NAS.. (UFJ/XRE.. or 12BNF..) bore code **03** to **07**

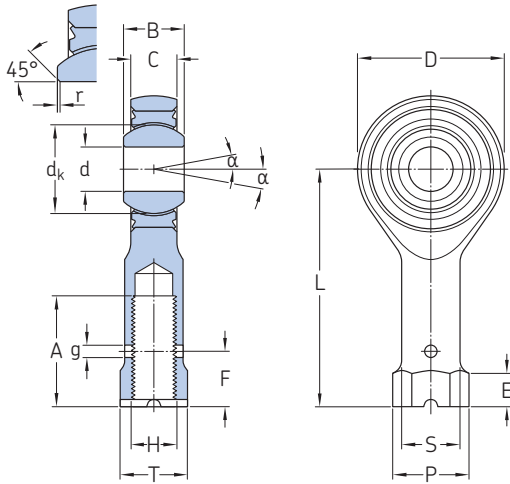

Technical specification	AS 81935
Product standard	AS 81935/5
Bearing	NAS..R inch (440C inner ring) ENAS..R inch (PH13.8 inner ring)

Keyway type	Bore code	Keyway shape	Number of slots
K	≤ 06	Rounded	2
	07 to 08	Rounded	4
	≥ 10	Square	4
W	All	Square	4

3.31

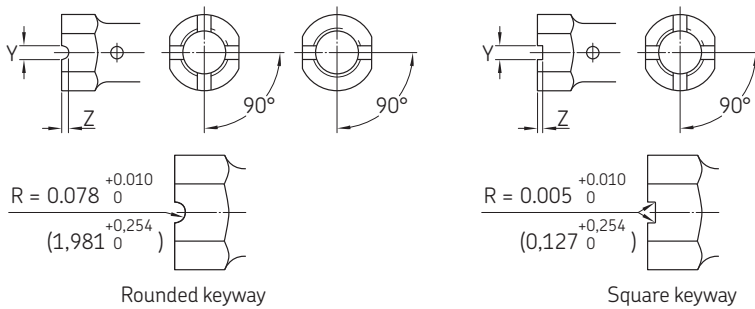

Dimensions

Nominal bore code	Dimensions								
	d	D	B	C	A	d _k	r	g	
	0/-0.0005	±0.010	0/-0.002	±0.005	Min	≈	±0.005	≈	
	0/-0,0127	±0,254	0/-0,051	±0,127			±0,127		

in/mm

03	0.1900 4,826	0.680 17,272	0.281 7,137	0.228 5,791	0.625 15,875	0.406 10,312	0.010 0,254	0.07 1,778
04	0.2500 6,350	0.827 21,006	0.343 8,712	0.260 6,604	0.625 15,875	0.500 12,704	0.010 0,254	0.07 1,778
05	0.3125 7,938	0.984 24,994	0.375 9,525	0.291 7,391	0.750 19,050	0.562 14,283	0.010 0,254	0.07 1,778
06	0.3750 9,525	1.131 28,727	0.406 10,312	0.322 8,179	1.000 25,400	0.625 15,872	0.010 0,254	0.07 1,778
07	0.4375 11,113	1.294 32,868	0.437 11,100	0.353 8,966	1.125 28,575	0.687 17,448	0.010 0,254	0.07 1,778

Dimensions cont.

Nominal bore code	Dimensions									
	H	L	P	F	S	T	E	Z ²⁾	Y ²⁾	
	UNJF-3B	±0.010	≈	±0.020	±0.010	+0.002/-0.010	+0.010/-0.062	+0.005/0	+0.005/0	
		±0,254		±0,508	±0,254	+0,051/-0,254	+0,254/-1,575	+0,127/0	+0,127/0	

in/mm

03	1/4-28 6,35-28	1.210 30,734	0.430 10,922	0.312 7,925	0.329 8,357	0.375 9,525	0.188 4,775	-	-
04	1/4-28 6,35-28	1.338 33,985	0.430 10,922	0.312 7,925	0.329 8,357	0.375 9,525	0.188 4,775	-	-
05	5/16-24 7,94-24	1.566 39,774	0.500 12,700	0.375 9,525	0.413 10,490	0.437 11,100	0.188 4,775	-	-
06	3/8-24 9,52-24	1.908 48,463	0.720 18,288	0.437 11,100	0.501 12,725	0.625 15,875	0.250 6,350	-	-
07	7/16-20 11,11-20	2.125 53,975	0.720 18,288	0.500 12,700	0.584 14,834	0.625 15,875	0.250 6,350	-	-

1) Parts are delivered and marked with UFJ/XRE.. and 12BNF.. standard references

2) K version

Cross-reference designation system to UFJ/XRE.. or 12BNF..

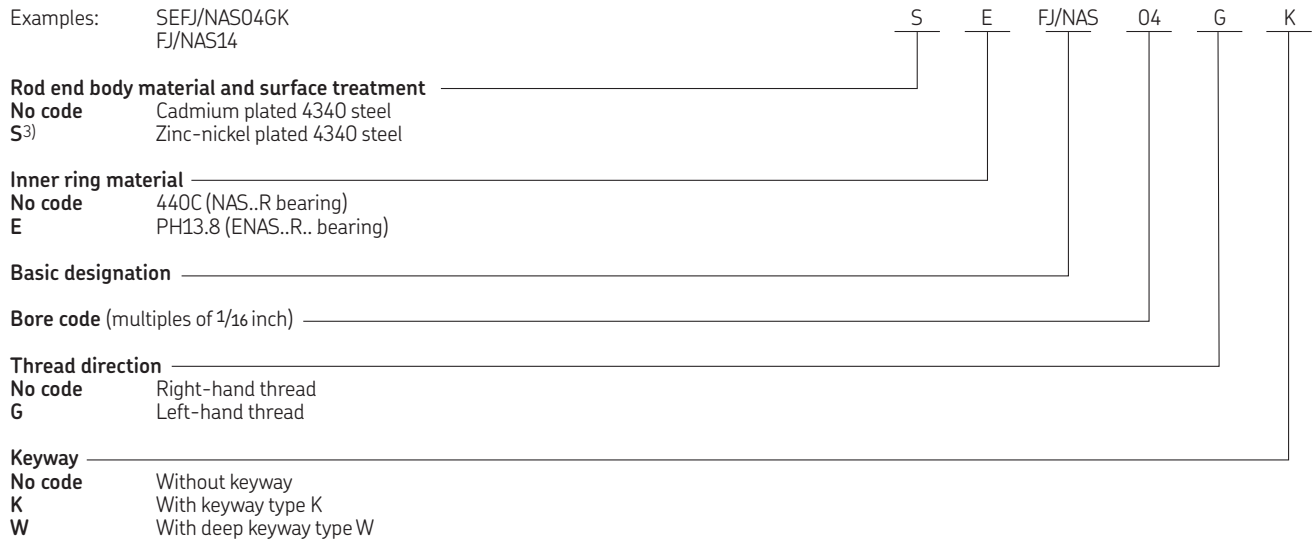

³⁾ SKF option

3.31



Dimensions cont., loads and torque

Nominal bore code	Dimensions		α	Mass \approx	Radial loads Ultimate	Fatigue 50 000 cycles	Starting torque
	Z ⁴⁾	Y ⁴⁾					
–	+0,005/0	+0,005/0					
	+0,127/0	+0,127/0					
	in/mm		°	lb/g	lbf/kN		lbf-in/Nm
03	0.110	0.062	10	0.044	3 000	1 100	0.5/6
	2,794	1,575		20	13,34	4,89	0,056/0,678
04	0.110	0.093	10	0.052	5 500	1 300	0.5/6
	2,794	2,362		24	24,46	5,78	0,056/0,678
05	0.110	0.093	10	0.087	8 900	2 000	1/15
	2,794	2,362		40	39,59	8,90	0,113/1,695
06	0.110	0.093	9	0.137	13 400	3 100	1/15
	2,794	2,362		62	59,60	13,79	0,113/1,695
07	0.110	0.093	8	0.193	18 200	4 200	1/15
	2,794	2,362		88	80,95	18,68	0,113/1,695

⁴⁾ W version

3.31 Internal thread inserted narrow self-lubricating spherical plain bearing rod end (inch dimensions)

FJ/NAS.. (UFJ/XRE.. or 12BNF..) bore 08 to 16

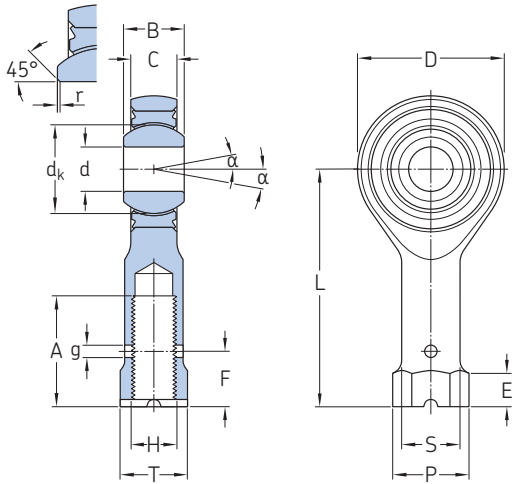

Technical specification	AS 81935
Product standard	AS 81935/5
Bearing	NAS..R inch (440C inner ring) ENAS..R inch (PH13.8 inner ring)

Keyway type	Bore code	Keyway shape	Number of slots
K	≤ 06	Rounded	2
	07 to 08	Rounded	4
	≥ 10	Square	4
W	All	Square	4

3.31

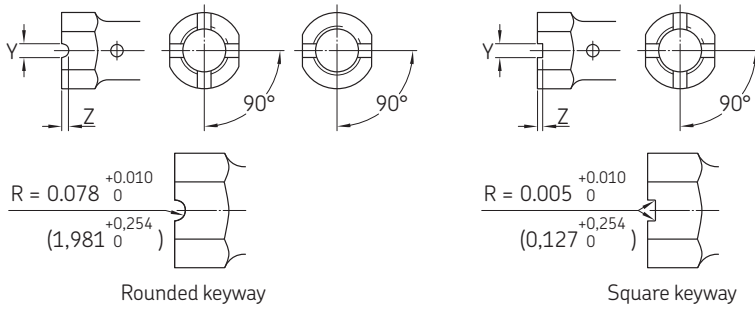

Dimensions

Nominal bore code	Dimensions							
	d	D	B	C	A	d_k	r	g
	0/-0.0005	±0.010	0/-0.002	±0.005	Min	≈	±0.005	≈
	0/-0,0127	±0,254	0/-0,051	±0,127			±0,127	
- in/mm								
08	0.5000 12,700	1.459 37,059	0.500 12,700	0.400 10,160	1.250 31,750	0.781 19,838	0.010 0,254	0.07 1,778
10	0.6250 15,875	1.763 44,780	0.625 15,875	0.510 12,954	1.375 34,925	0.968 24,583	0.010 0,254	0.07 1,778
12	0.7500 19,050	2.140 54,356	0.750 19,050	0.603 15,316	1.625 41,275	1.187 30,149	0.010 0,254	0.07 1,778
14	0.8750 22,225	2.372 60,249	0.875 22,225	0.713 18,110	1.875 47,625	1.314 33,370	0.010 0,254	0.07 1,778
16	1.0000 25,400	2.681 68,097	1.000 25,400	0.807 20,498	2.125 53,975	1.500 38,099	0.010 0,254	0.07 1,778

Dimensions cont.

Nominal bore code	Dimensions								
	H	L	P	F	S	T	E	Z ²⁾	Y ²⁾
	UNJF-3B	±0.010	≈	±0.020	±0.010	+0.002/-0.010	+0.010/-0.062	+0.005/0	+0.005/0
		±0,254		±0,508	±0,254	+0,051/-0,254	+0,254/-1,575	+0,127/0	+0,127/0
- in/mm									
08	1/2-20 12,7-20	2.356 59,842	1.020 25,908	0.562 14,275	0.672 17,069	0.875 22,225	0.375 9,525	-	-
10	5/8-18 15,87-18	2.707 68,758	1.020 25,908	0.687 17,450	0.845 21,463	0.875 22,225	0.375 9,525	0.077	0.125
12	3/4-16 19,05-16	3.193 81,102	1.300 33,020	0.812 20,625	1.017 25,832	1.125 28,575	0.500 12,700	0.077	0.125
14	7/8-14 22,22-14	3.677 93,396	1.375 34,925	0.937 23,800	1.187 30,150	1.250 31,750	0.500 12,700	0.086	0.156
16	1-12 25,4-12	4.101 104,165	1.590 40,386	1.062 26,975	1.356 34,442	1.375 34,925	0.500 12,700	0.094	0.156
								2,388	3,962

1) Parts are delivered and marked with UFJ/XRE.. and 12BNF.. standard references

2) K version

Cross-reference designation system to UFJ/XRE.. or 12BNF..

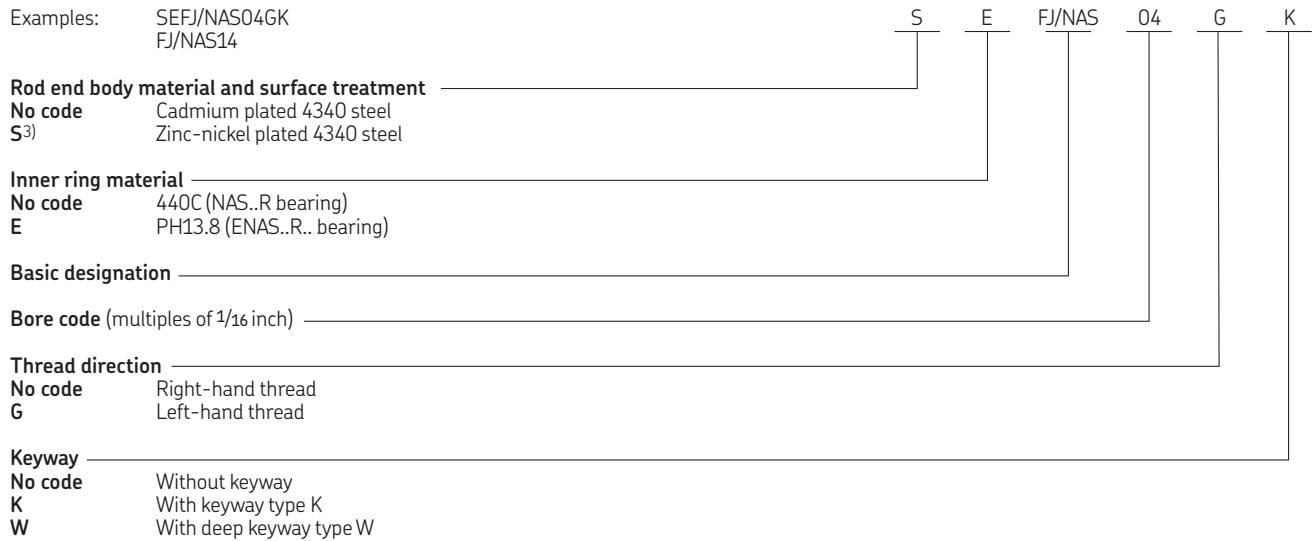

³⁾ SKF option

3.31



Dimensions cont., loads and torque

Nominal bore code	Dimensions		α	Mass \approx	Radial loads Ultimate	Fatigue 50 000 cycles	Starting torque
	Z ⁴⁾	Y ⁴⁾					
	+0,005/0	+0,005/0					
	+0,127/0	+0,127/0					
–	in/mm		°	lb/g	lbf/kN		lbf-in/Nm
08	0.110	0.093	8	0.279	24 600	5 700	1/15
	2,794	2,362		127	109,42	25,35	0,113/1,695
10	0.110	0.125	8	0.504	39 500	9 200	1/15
	2,794	3,175		229	175,70	40,92	0,113/1,695
12	0.110	0.125	8	0.860	57 200	13 500	1/15
	2,794	3,175		390	254,43	60,05	0,113/1,695
14	0.110	0.125	8	1.266	77 800	18 400	1/24
	2,794	3,175		574	346,05	81,85	0,113/2,712
16	0.110	0.125	9	1.814	101 000	24 000	1/24
	2,794	3,175		823	449,25	106,75	0,113/2,712

⁴⁾ W version

3.32 Internal thread inserted narrow self-lubricating spherical plain bearing rod end (inch dimensions)

PHFJ/NAS.. (PHUFJ/XRE.. or 12CNF..)² bore code **03 to 07**

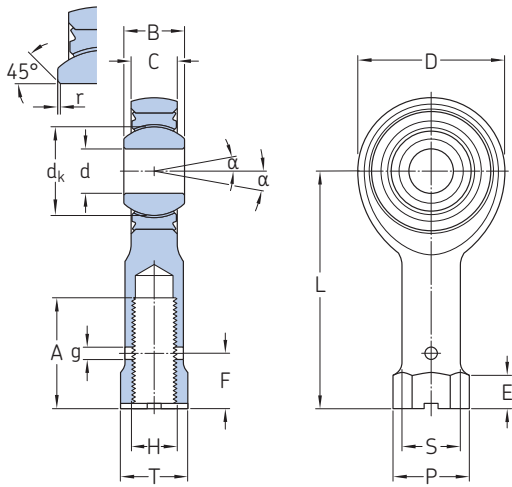

Technical specification	AS 81935
Product standard	AS 81935/9
Rod end body	PH13.8 passivated
Bearing	NAS..R inch (440C inner ring) ENAS..R inch (PH13.8 inner ring)

Keyway type	Bore code	Keyway shape	Number of slots
K	≤ 06	Rounded	2
	07 to 08	Rounded	4
	≥ 10	Square	4
W	All	Square	4

3.32

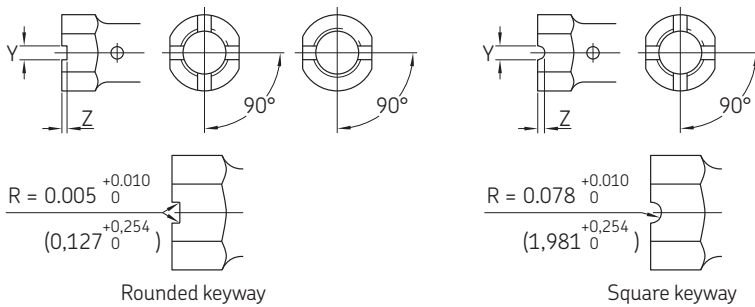

Dimensions

Nominal bore code	Dimensions								
	d	D	B	C	A	d _k	r	g	
	0/-0.0005	±0.010	0/-0.002	±0.005	Min	≈	±0.005	≈	
	0/-0.0127	±0.254	0/-0.051	±0.127			±0.127		

in/mm

03	0.1900 4,826	0.680 17,272	0.281 7,137	0.228 5,791	0.625 15,875	0.406 10,312	0.010 0,254	0.07 1,778
04	0.2500 6,350	0.827 21,006	0.343 8,712	0.260 6,604	0.625 15,875	0.500 12,704	0.010 0,254	0.07 1,778
05	0.3125 7,938	0.984 24,994	0.375 9,525	0.291 7,391	0.750 19,050	0.562 14,283	0.010 0,254	0.07 1,778
06	0.3750 9,525	1.131 28,727	0.406 10,312	0.322 8,179	1.000 25,400	0.625 15,872	0.010 0,254	0.07 1,778
07	0.4375 11,113	1.294 32,868	0.437 11,100	0.353 8,966	1.125 28,575	0.687 17,448	0.010 0,254	0.07 1,778

Dimensions cont.

Nominal bore code	Dimensions									
	H	L	P	F	S	T	E	Z ¹⁾	Y ¹⁾	
	UNJF-3B	±0.010	≈	±0.020	±0.010	+0.002/-0.010	+0.010/-0.062	+0.005/0	+0.005/0	
		±0.254		±0.508	±0.254	+0.051/-0.254	+0.254/-1.575	+0.127/0	+0.127/0	

in/mm

03	1/4-28 6,35-28	1.210 30,734	0.430 10,922	0.312 7,925	0.329 8,357	0.375 9,525	0.188 4,775	-	-
04	1/4-28 6,35-28	1.338 33,985	0.430 10,922	0.312 7,925	0.329 8,357	0.375 9,525	0.188 4,775	-	-
05	5/16-24 7,94-24	1.566 39,774	0.500 12,700	0.375 9,525	0.413 10,490	0.437 11,100	0.188 4,775	-	-
06	3/8-24 9,52-24	1.908 48,463	0.720 18,288	0.437 11,100	0.501 12,725	0.625 15,875	0.250 6,350	-	-
07	7/16-20 11,11-20	2.125 53,975	0.720 18,288	0.500 12,700	0.584 14,834	0.625 15,875	0.250 6,350	-	-

¹⁾ K version ²⁾ Parts are delivered and marked with PHUFJ/XRE.. or 12CNF.. standard references

Cross-reference designation system to PHUFJ/XRE.. or 12CNF..



Dimensions cont., loads and torque

Nominal bore code	Dimensions		α	Mass \approx	Radial loads Ultimate	Fatigue 50 000 cycles	Starting torque
	Z ³⁾	Y ³⁾					
	+0,005/0 +0,127/0	+0,005/0 +0,127/0					
–	in/mm		°	lb/g	lbf/kN		lbf-in/Nm
03	0.110 2,794	0.062 1,575	10	0.044 20	3 000 13,34	1 100 4,89	0.5/6 0,056/0,678
04	0.110 2,794	0.093 2,362	10	0.052 24	5 500 24,46	1 300 5,78	0.5/6 0,056/0,678
05	0.110 2,794	0.093 2,362	10	0.087 40	8 900 39,59	2 000 8,9	1/15 0,113/1,695
06	0.110 2,794	0.093 2,362	9	0.137 62	13 400 59,60	3 100 13,79	1/15 0,113/1,695
07	0.110 2,794	0.093 2,362	8	0.193 88	18 200 80,95	4 200 18,68	1/15 0,113/1,695

³⁾ W version

3.32 Internal thread inserted narrow self-lubricating spherical plain bearing rod end (inch dimensions)

PHFJ/NAS.. (PHUFJ/XRE.. or 12CNF..) bore code **08 to 16**

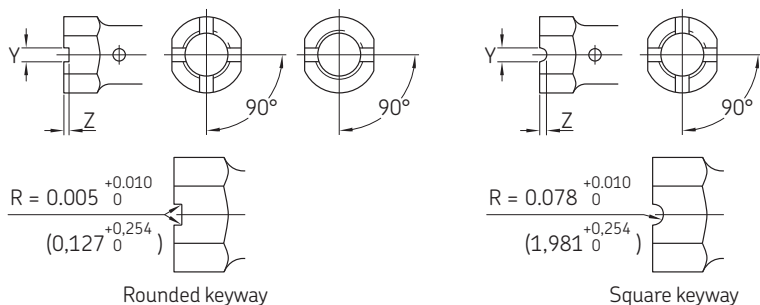
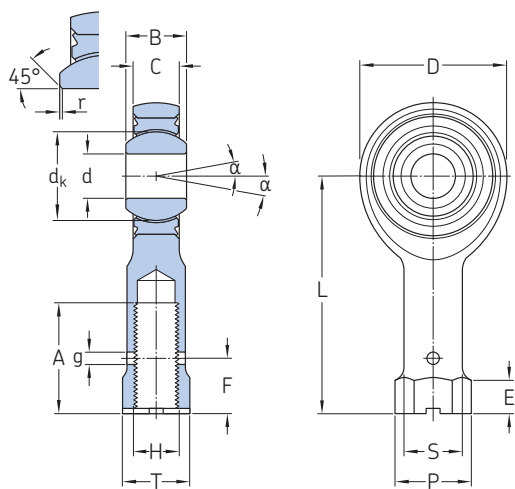

Technical specification	AS 81935
Product standard	AS 81935/9
Rod end body	PH13.8 passivated
Bearing	NAS..R inch (440C inner ring) ENAS..R inch (PH13.8 inner ring)

Keyway type	Bore code	Keyway shape	Number of slots
K	≤ 06	Rounded	2
	07 to 08	Rounded	4
	≥ 10	Square	4
W	All	Square	4

3.32

Dimensions

Nominal bore code	Dimensions							
	d	D	B	C	A	d _k	r	g
	0/-0.0005	±0.010	0/-0.002	±0.005	Min	≈	±0.005	≈
	0/-0,0127	±0,254	0/-0,051	±0,127			±0,127	
- in/mm								
08	0.5000 12,700	1.459 37,059	0.500 12,700	0.400 10,160	1.250 31,750	0.781 19,838	0.010 0,254	0.07 1,778
10	0.6250 15,875	1.763 44,780	0.625 15,875	0.510 12,954	1.375 34,925	0.968 24,583	0.010 0,254	0.07 1,778
12	0.7500 19,050	2.140 54,356	0.750 19,050	0.603 15,316	1.625 41,275	1.187 30,149	0.010 0,254	0.07 1,778
14	0.8750 22,225	2.372 60,249	0.875 22,225	0.713 18,110	1.875 47,625	1.314 33,370	0.010 0,254	0.07 1,778
16	1.0000 25,400	2.681 68,097	1.000 25,400	0.807 20,498	2.125 53,975	1.500 38,099	0.010 0,254	0.07 1,778

Dimensions cont.

Nominal bore code	Dimensions								
	H	L	P	F	S	T	E	Z ¹⁾	Y ¹⁾
	UNJF-3B	±0.010	≈	±0.020	±0.010	+0.002/-0.010	+0.010/-0.062	+0.005/0	+0.005/0
		±0,254		±0,508	±0,254	+0,051/-0,254	+0,254/-1,575	+0,127/0	+0,127/0
- in/mm									
08	1/2-20 12,7-20	2.356 59,842	1.020 25,908	0.562 14,275	0.672 17,069	0.875 22,225	0.375 9,525	-	-
10	5/8-18 15,87-18	2.707 68,758	1.020 25,908	0.687 17,450	0.845 21,463	0.875 22,225	0.375 9,525	0.077	0.125
12	3/4-16 19,05-16	3.193 81,102	1.300 33,020	0.812 20,625	1.017 25,832	1.125 28,575	0.500 12,700	0.077	0.125
14	7/8-14 22,22-14	3.677 93,396	1.375 34,925	0.937 23,800	1.187 30,150	1.250 31,750	0.500 12,700	0.086	0.156
16	1-12 25,4-12	4.101 104,165	1.590 40,386	1.062 26,975	1.356 34,442	1.375 34,925	0.500 12,700	0.094	0.156
								2,388	3,962

¹⁾ K version ²⁾ Parts are delivered and marked with PHUFJ/XRE.. or 12CNF.. standard references

Cross-reference designation system to PHUFJ/XRE.. or 12CNF..



Dimensions cont., loads and torque

Nominal bore code	Dimensions		α	Mass \approx	Radial loads		Starting torque
	Z ³⁾	Y ³⁾			Ultimate	Fatigue 50 000 cycles	
–	in/mm	°	lb/g	lbf/kN	lbf-in/Nm		
08	0.110	0.093	8	0.279	24 600	5 700	1/15
	2,794	2,362					0,113/1,695
10	0.110	0.125	8	0.504	39 500	9 200	1/15
	2,794	3,175					0,113/1,695
12	0.110	0.125	8	0.860	57 200	13 500	1/15
	2,794	3,175					0,113/1,695
14	0.110	0.156	8	1.266	77 800	18 400	1/24
	2,794	3,962					0,113/2,712
16	0.110	0.156	9	1.814	101 000	24 000	1/24
	2,794	3,962					0,113/2,712

³⁾ W version

3.33 Internal thread inserted self-lubricating spherical plain bearing rod end (inch dimensions)

R..F. bore code **03** to **08**

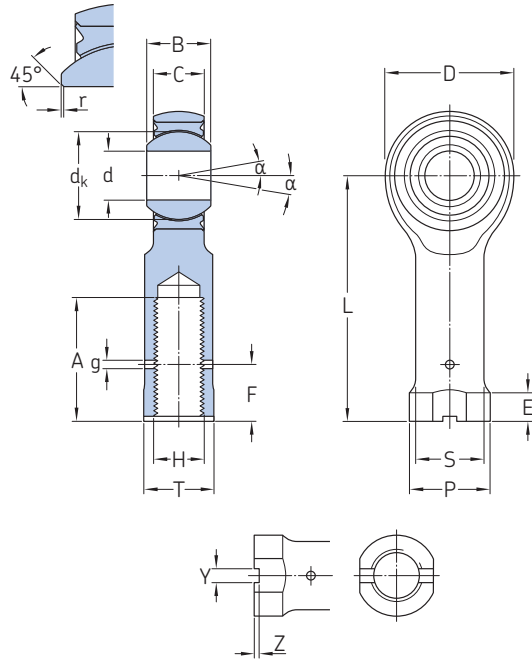

Technical specification	AS 81935
Product standard	NSA 8149
Liner	X1
Inner ring	Corrosion-resistant steel 440C
Outer ring	Corrosion-resistant steel 17-4PH H1150
Rod end body	Corrosion-resistant steel or alloy steel
Bearing	SW..G inch

Dimensions

Nominal bore code	Dimensions							
	d	B	D	C	L	r	T	P
	0/-0.0005 0/-0,0127	0/-0.002 0/-0,051	±0.010 ±0,254	±0.005 ±0,127	±0.010 ±0,254		±0.010 ±0,254	±0.010 ±0,254

– in/mm

03	0.1900 4,826	0.437 11,099	0.806 20,472	0.337 8,560	1.375 34,925	0.005/0.015 0,127/0,381	0.437 11,099	0.500 12,700
04	0.2500 6,350	0.437 11,099	0.806 20,472	0.337 8,560	1.469 37,312	0.005/0.015 0,127/0,381	0.437 11,099	0.500 12,700
05	0.3125 7,938	0.437 11,099	0.900 22,860	0.327 8,306	1.375 34,925	0.005/0.015 0,127/0,381	0.437 11,099	0.500 12,700
06	0.3750 9,525	0.500 12,700	1.025 26,035	0.416 10,566	1.625 41,275	0.005/0.015 0,127/0,381	0.582 14,782	0.625 15,875
07	0.4375 11,113	0.562 14,274	1.150 29,210	0.452 11,481	1.812 46,024	0.005/0.015 0,127/0,381	0.625 15,875	0.687 17,449
08	0.5000 12,700	0.625 15,875	1.337 33,960	0.515 13,081	2.125 53,975	0.005/0.015 0,127/0,381	0.750 19,050	0.812 20,624

Dimensions cont.

Nominal bore code	Dimensions							
	F	E	H	A	S	d _k	Z	Y
	±0.015 ±0,381	±0.010 ±0,254	UNJF-3B	+0.060/-0.030 +1,524/-0,762	+0.005/-0.005 +0,127/-0,127	≈	+0.005/0 +0,127/0	+0.005/0 +0,127/0

– in/mm

03	0.380 9,652	0.250 6,350	5/16-24	0.750 19,050	0.422 10,718	0.531 13,487	0.056 1,422	0.062 1,574
04	0.380 9,652	0.250 6,350	5/16-24	0.750 19,050	0.422 10,718	0.531 13,487	0.056 1,422	0.062 1,574
05	0.380 9,652	0.250 6,350	5/16-24	0.750 19,050	0.422 10,718	0.593 15,062	0.056 1,422	0.062 1,574
06	0.440 11,176	0.250 6,350	3/16-24	0.937 23,799	0.567 14,401	0.687 17,449	0.056 1,422	0.093 2,362
07	0.500 12,700	0.250 6,350	7/16-20	1.062 26,975	0.610 15,494	0.781 19,837	0.069 1,752	0.093 2,362
08	0.560 14,224	0.250 6,350	1/2-20	1.125 28,575	0.735 18,669	0.875 22,225	0.069 1,752	0.093 2,362



Designation system

Examples: R03FLCKS
R12FR

R 03 F L C K S

Basic designation

Bore code (multiples of 1/16 inch)

Thread direction

R Right-hand thread
L Left-hand thread

Surface treatment of rod end body

No code¹⁾ No treatment
C Cadmium plated
J¹⁾ Zinc-nickel plated

Keyway

No code Without keyway
K¹⁾ With keyway

Rod end body material

No code¹⁾ Corrosion-resistant steel 17-4PH H1025
S Alloy steel

¹⁾ SKF option

Dimensions cont., loads and torque

Nominal bore code	Dimensions		Mass ≈	Radial loads Ultimate	Fatigue 50 000 cycles	Starting torque ²⁾ Max
	g	α				
–	in/mm	°	lb/g	lbf/kN		lbf-in/Nm
03	0.07	17	0.06	4 800	1 470,25	6
	1,778		27,21	21,35	6,54	0,677
04	0.07	17	0.06	4 800	2 380,73	6
	1,778		27,21	21,35	10,59	0,677
05	0.07	14	0.07	5 500	2 769,65	10
	1,778		31,75	24,47	12,32	1,129
06	0.07	10	0.11	7 000	3 569,97	10
	1,778		49,89	31,14	15,88	1,129
07	0.07	12	0.18	8 100	4 799,67	10
	1,778		81,64	36,03	21,35	1,129
08	0.07	9	0.28	14 200	7 679,48	10
	1,778		127	63,16	34,16	1,129

²⁾ Minimum starting torque limited by zero radial and axial clearance.

3.33 Internal thread inserted self-lubricating spherical plain bearing rod end (inch dimensions)

R..F. bore code **10** to **16B**

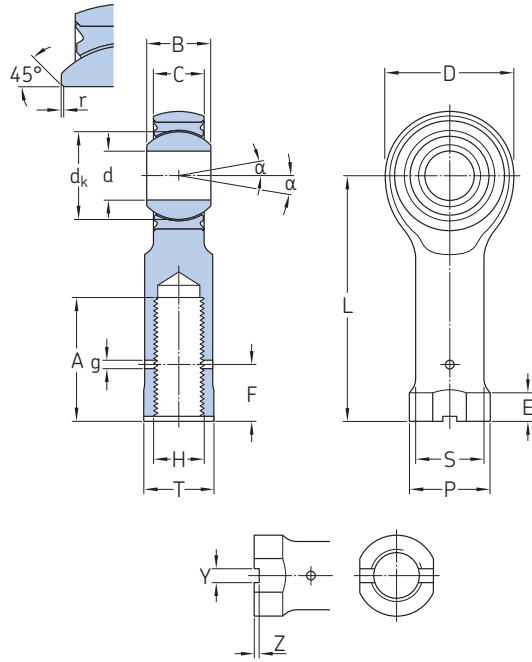

Technical specification	AS 81935
Product standard	NSA 8149
Liner	X1
Inner ring	Corrosion-resistant steel 440C
Outer ring	Corrosion-resistant steel 17-4PH H1150
Rod end body	Corrosion-resistant steel or alloy steel
Bearing	SW..G inch

Dimensions

Nominal bore code	Dimensions							
	d	B	D	C	L	r	T	P
	0/-0.0005 0/-0,0127	0/-0.002 0/-0,051	±0.010 ±0,254	±0.005 ±0,127	±0.010 ±0,254		±0.010 ±0,254	±0.010 ±0,254
	in/mm							
10	0.6250 15,875	0.750 19,050	1.525 38,735	0.577 14,656	2.625 66,675	0.005/0.015 0,127/0,381	0.875 22,225	1.000 25,400
12	0.7500 19,050	0.875 22,225	1.775 45,085	0.640 16,256	2.875 73,025	0.005/0.015 0,127/0,381	1.000 25,400	1.060 26,924
14	0.8750 22,225	0.875 22,225	2.025 51,435	0.765 19,431	3.375 85,725	0.005/0.015 0,127/0,381	1.125 28,575	1.187 30,150
16¹⁾	1.0000 25,400	1.375 34,925	2.775 70,485	1.015 25,781	4.125 104,775	0.005/0.015 0,127/0,381	1.500 38,100	1.625 41,275
16B	1.0000 25,400	1.375 34,925	2.775 70,485	1.015 25,781	4.125 104,775	0.005/0.015 0,127/0,381	1.250 31,750	1.312 33,325

Dimensions cont.

Nominal bore code	Dimensions							
	F	E	H	A	S	d _k	Z	Y
	±0.015 ±0,381	±0.010 ±0,254	UNJF-3B	+0.060/-0.030 +1,524/-0,762	+0.005/-0.005 +0,127/-0,127	≈	+0.005/0 +0,127/0	+0.005/0 +0,127/0
	in/mm			in/mm				
10	0.690 17,526	0.250 6,350	5/8-20	1.500 38,100	0.860 21,844	1.062 26,974	0.077 1,955	0.125 3,175
12	0.820 20,828	0.250 6,350	3/4-16	1.620 41,148	0.985 25,019	1.250 31,750	0.077 1,955	0.125 3,175
14	0.940 23,876	0.250 6,350	7/8-14	1.875 47,625	1.110 28,194	1.375 34,925	0.086 2,184	0.156 3,962
16¹⁾	1.070 27,178	0.250 6,350	1 1/4-12	2.125 53,975	1.485 37,719	1.937 49,200	0.094 2,387	0.156 3,962
16B	1.070 27,178	0.250 6,350	1-12	2.125 53,975	1.485 37,719	1.937 49,200	0.094 2,387	0.156 3,962

¹⁾ SKF option



Designation system

Examples: R03FLCKS
R12FR

R 03 F L C K S

Basic designation

Bore code (multiples of 1/16 inch)

Thread direction

R Right-hand thread
L Left-hand thread

Surface treatment of rod end body

No code¹⁾ No treatment
C Cadmium plated
J¹⁾ Zinc-nickel plated

Keyway

No code Without keyway
K¹⁾ With keyway

Rod end body material

No code¹⁾ Corrosion-resistant steel 17-4PH H1025
S Alloy steel

1) SKF option

Dimensions cont., loads and torque

Nominal bore code	Dimensions		Mass ≈	Radial loads Ultimate	Fatigue 50 000 cycles	Starting torque ²⁾ Max
	g ≈	α °				
–	in/mm	°	lb/g	lbf/kN		lbf-in/Nm
10	0.07	12	0.42	16 150	9 178,95	10
	1,778		190,50	71,84		40,83
12	0.07	14	0.51	21 000	11 600,14	10
	1,778		231,33	93,41		51,6
14	0.07	7	0.94	26 000	13 099,62	16
	1,778		426,37	115,65		58,27
16¹⁾	0.07	15	1.35	55 500	30 400,92	16
	1,778		612,34	246,88		135,23
16B	0.07	15	1.35	55 500	30 400,92	16
	1,778		612,34	246,88		135,23

2) Minimum starting torque limited by zero radial and axial clearance.

3.34 Internal thread inserted wide self-lubricating spherical plain bearing rod end (inch dimensions)

EFJ/RL..R

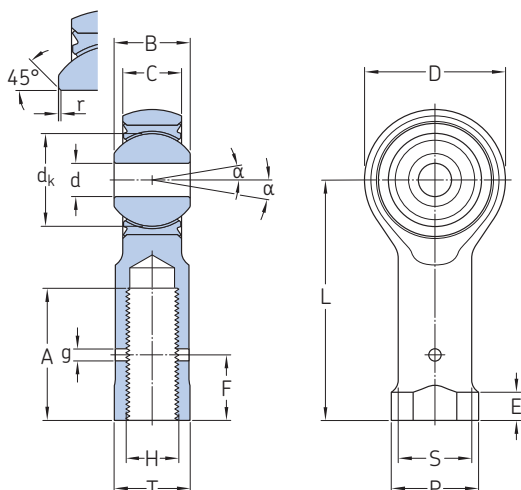

Technical specification	AS 81820 for the bearing
Product standard	-
Bearing	WAS..R inch

3.34



Dimensions

Nominal bore code	Dash number multiples of 1/16 inch	Dimensions										
		d	D	B	C	A	d _k	r	H	L	P	
		0/-0.0005	±0.010	0/-0.002	±0.005	+0.06/-0.03	d _k	±0.005	UNJF-3B	±0.010	P	
		0/-0.0127	±0,254	0/-0,051	±0,127	+1,524/-0,762	≈	±0,127	-	±0,254	±0,254	
-		in/mm							-	in/mm		
4,83	03	0.1900	0.806	0.437	0.337	0.750	0.530	0.010	5/16-24	1.375	0,500	
		4,826	20,472	11,100	8,56	19,050	13,464	0,254	7,94-24	34,925	12,700	
6,35	04	0.2500	0.806	0.437	0.337	0.750	0.530	0.010	5/16-24	1.469	0,500	
		6,350	20,472	11,100	8,56	19,050	13,464	0,254	7,94-24	37,312	12,700	
7,94	05	0.3125	0.900	0.437	0.327	0.750	0.566	0.010	5/16-24	1.375	0,500	
		7,938	22,860	11,100	8,306	19,050	14,381	0,254	7,94-24	34,925	12,700	
9,52	06	0.3750	1.025	0.500	0.416	0.937	0.683	0.010	3/8-24	1.625	0,625	
		9,525	26,035	12,700	10,566	23,780	17,361	0,254	9,52-24	41,275	15,875	
11,11	07	0.4375	1.150	0.562	0.452	1.062	0.777	0.010	7/16-20	1.812	0,687	
		11,113	29,210	14,275	11,481	26,975	19,744	0,254	11,11-20	46,025	17,450	
12,7	08	0.5000	1.337	0.625	0.515	1.125	0.871	0.010	1/2-20	2.125	0,812	
		12,700	33,960	15,875	13,081	28,575	22,130	0,254	12,7-20	53,975	20,625	
15,87	10	0.6250	1.525	0.750	0.577	1.500	1.059	0.010	5/8-18	2.625	1,000	
		15,875	38,735	19,050	14,656	38,100	26,887	0,254	15,87-18	66,675	25,400	
19,05	12	0.7500	1.775	0.875	0.640	1.620	1.216	0.010	3/4-16	2.875	1,060	
		19,050	45,085	22,225	16,256	41,148	30,897	0,254	19,05-16	73,025	26,924	
22,22	14	0.8750	2.025	0.875	0.765	1.875	1.325	0.010	7/8-14	3.375	1,187	
		22,225	51,435	22,225	19,431	47,625	33,655	0,254	22,22-14	85,725	30,150	
25,4	16	1.0000	2.775	1.375	1.015	2.125	1.871	0.010	1-12	4.125	1,312	
		25,400	70,485	34,925	25,781	53,975	47,526	0,254	25,4-12	104,775	33,325	

Designation system

Examples: XEFJ/RL 6,35RGX
EFJ/RL22,22

X EFJ/RL 6,35 R G X

Rod end body material

No code Cadmium plated 30NCD16 steel
S Zinc-nickel plated 30NCD16 steel
X Corrosion-resistant steel 17-4PH H1025
T¹⁾ Anodized titanium

Basic designation

Bore code

Thread direction

No code Right-hand thread
G Left-hand thread

Starting torque

No code Standard
X Reduced

1) SKF option, masses and load carrying capability reduced compared to steel rod end body

Dimensions cont., loads and torque

Nominal bore code	Dash number multiples of 1/16 inch	Dimensions		S ±0,005 ±0,127	T +0,003/-0,010 +1,524/-0,762	g ≈	α	Mass ≈	Radial loads		Starting torque	
		F ±0,015 ±0,381	E ≈						Ultimate ¹⁾	Fatigue 10 ⁶ cycles	Standard	Reduced
		in/mm				°	lb/g	lbf/kN	lbf-in/Nm			
4,83	03	0,380	0,25	0,422	0,437	0,07	16	0,07	6 195	1 052	0,53/10	1,1 max
		9,652	6,35	10,719	11,100	1,778		32	27,56	4,68	0,06/1,12	0,12 max
6,35	04	0,380	0,25	0,422	0,437	0,07	16	0,07	6 195	1 052	0,53/10	1,1 max
		9,652	6,35	10,719	11,100	1,778		32	27,56	4,68	0,06/1,12	0,12 max
7,94	05	0,380	0,25	0,422	0,437	0,07	15	0,10	7 585	1 090	1/10	2 max
		9,652	6,35	10,719	11,100	1,778		45	33,74	4,85	0,11/1,12	0,22 max
9,52	06	0,440	0,25	0,567	0,582	0,07	9	0,12	8 940	1 513	1/10	2 max
		11,176	6,35	14,402	14,782	1,778		55	39,77	6,73	0,11/1,12	0,22 max
11,11	07	0,500	0,25	0,610	0,625	0,07	11	0,20	9 595	1 920	1/10	2 max
		12,700	6,35	15,494	15,875	1,778		92	42,68	8,54	0,11/1,12	0,22 max
12,7	08	0,560	0,25	0,735	0,750	0,07	9	0,28	18 750	3 069	1/10	2 max
		14,224	6,35	18,669	19,050	1,778		140	83,40	13,65	0,11/1,12	0,22 max
15,87	10	0,690	0,25	0,860	0,875	0,07	12	0,45	20 680	3 480	1/10	2 max
		17,526	6,35	21,844	22,225	1,778		205	91,99	15,48	0,11/1,12	0,22 max
19,05	12	0,820	0,25	0,985	1,000	0,07	13	0,55	27 795	4 586	1/10	2 max
		20,828	6,35	25,019	25,400	1,778		250	123,64	20,40	0,11/1,12	0,22 max
22,22	14	0,940	0,25	1,110	1,125	0,07	6	1,00	31 725	5 348	2/15,9	4,1 max
		23,876	6,35	28,194	28,575	1,778		450	141,12	23,79	0,23/1,8	0,46 max
25,4	16	1,070	0,25	1,235	1,250	0,07	12	1,45	71 745	8 377	2/15,9	4,1 max
		27,178	6,35	31,369	31,750	1,778		660	319,14	37,26	0,23/1,8	0,46 max

1) Loads are valid for rod end bodies made of alloy steel or corrosion resistant steel. For other rod ends, refer to page 292

3.35 Internal thread inserted high misalignment self-lubricating spherical plain bearing rod end (inch dimensions)

EFJ/RT..R

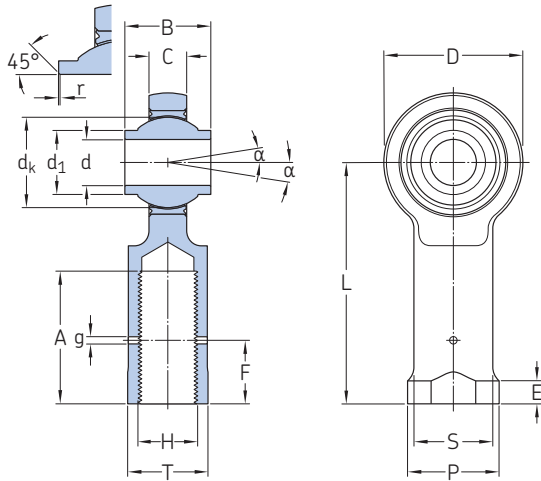

Technical specification	-
Product standard	-
Bearing	XRT..R inch

3.35

Dimensions

Nominal bore code	Dash number multiples of 1/16 inch	Dimensions		B	C	A	H	dk	d1	r	L	P
		d	D									
		0/-0.0005	+0.035/-0.010	0/-0.005	±0.005	+0.06/-0.03	UNJF-3B	≈	≈	+0.012/0	±0.010	±0.010
		0/-0.0127	+889/-0.254	0/-0.127	±0.127	+1,524/-0,762				+0,3/0	±0,254	±0,254
-		in/mm		-	in/mm							
4,83	03	0.1900 4,826	0.750 19,050	0.500 12,700	0.220 5,588	0.750 19,050	5/16-24 7,94-24	0.437 11,100	0.315 8,001	0.004 0,100	1.375 34,925	0.500 12,700
6,35	04	0.2500 6,350	1.000 25,400	0.593 15,062	0.265 6,731	0.937 23,780	3/8-24 9,52-24	0.594 15,080	0.386 9,804	0.004 0,100	1.625 41,275	0.625 15,875
7,94	05	0.3125 7,938	1.125 28,575	0.813 20,650	0.355 9,017	1.062 26,975	7/16-20 11,11-20	0.781 19,838	0.512 13,005	0.004 0,100	1.812 46,025	0.687 17,450
9,52	06	0.3750 9,525	1.125 28,575	0.813 20,650	0.355 9,017	1.062 26,975	7/16-20 11,11-20	0.781 19,838	0.532 13,513	0.004 0,100	1.812 46,025	0.687 17,450
11,11	07	0.4375 11,113	1.312 33,325	0.875 22,225	0.355 9,017	1.125 28,575	1/2-20 12,7-20	0.866 22,000	0.620 15,748	0.004 0,100	2.125 53,975	0.812 20,625
12,7	08	0.5000 12,700	1.500 38,100	0.937 23,799	0.411 10,439	1.500 38,100	5/8-18 15,87-18	0.984 25,000	0.728 18,491	0.004 0,100	2.625 66,675	1.000 25,400
15,87	10	0.6250 15,875	1.750 44,450	1.200 30,480	0.577 14,656	1.750 44,450	3/4-16 19,05-16	1.240 31,500	0.857 21,768	0.004 0,100	2.875 73,025	1.060 26,924
19,05	12	0.7500 19,050	2.000 50,800	1.280 32,512	0.630 16,002	1.875 47,625	7/8-14 22,22-14	1.339 34,000	0.963 24,460	0.004 0,100	3.375 85,725	1.187 30,150
22,22	14	0.8750 22,225	2.200 55,880	1.400 35,560	0.635 16,219	2.000 50,800	7/8-14 22,22-14	1.531 38,887	1.122 28,500	0.004 0,100	3.375 85,725	1.187 30,150
25,4	16	1.0000 25,400	2.750 69,850	1.875 47,625	0.845 21,463	2.125 53,975	1 1/4-12 31,75-12	1.875 47,625	1.272 32,309	0.004 0,100	4.125 104,775	2.020 51,308

Designation system

Examples: XEFJ/RT 6,35RGX
EFJ/RT22,22

X EFJ/RT 6,35 R G X

Rod end body material

No code Cadmium plated 30NCD16 steel
S Zinc-nickel plated 30NCD16 steel
X Corrosion-resistant steel 17-4PH H1025
T¹⁾ Anodized titanium

Basic designation

Bore code

Thread direction

No code Right-hand thread
G Left-hand thread

Starting torque

No code Standard
X Reduced

¹⁾ SKF option, masses and load carrying capability reduced compared to steel rod end body

Dimensions cont., loads and torque

Nominal bore code	Dash number multiples of 1/16 inch	Dimensions		E ≈	S ±0.005 ±0,127	T ±0.010 ±0,254	α	Mass ≈	Radial loads		Starting torque	
		g	F ±0.015 ±0,381						Ultimate ¹⁾	Fatigue 10 ⁶ cycles	Standard	Reduced
		in/mm				°	lb/g	lbf/kN			lbf-in/Nm	
4,83	03	0.07	0.380	0.25	0.422	0.437	15	0.07	4800	762	0.53/5	1 max
		1,778	9,652	6,35	10,719	11,100		31	21,35	3,39	0,06/0,56	0,12 max
6,35	04	0.07	0.440	0.25	0.567	0.582	24	0.13	8185	1 311	0.53/5	1 max
		1,778	11,176	6,35	14,402	14,782		60	36,41	5,83	0,06/0,56	0,12 max
7,94	05	0.07	0.500	0.25	0.610	0.625	23	0.19	8620	1 414	0.7/7	2 max
		1,778	12,700	6,35	15,494	15,875		85	38,34	6,29	0,08/0,8	0,22 max
9,52	06	0.07	0.500	0.25	0.610	0.625	22	0.19	8620	1 414	0.88/9	2 max
		1,778	12,700	6,35	15,494	15,875		85	38,34	6,29	0,10/1,02	0,22 max
11,11	07	0.07	0.560	0.25	0.735	0.750	22	0.31	13025	2 104	0.88/9	2 max
		1,778	14,224	6,35	18,669	19,050		140	57,94	9,36	0,10/1,02	0,22 max
12,7	08	0.07	0.690	0.25	0.860	0.875	20	0.49	18165	2 947	0.88/9	2 max
		1,778	17,526	6,35	21,844	22,225		220	80,80	13,11	0,10/1,02	0,22 max
15,87	10	0.07	0.820	0.25	0.985	1.000	20	0.71	24010	3 973	1/12.4	2 max
		1,778	20,828	6,35	25,019	25,400		321	106,80	17,67	0,11/1,4	0,22 max
19,05	12	0.07	0.940	0.25	1.110	1.125	19	0.97	26990	5 052	1/12.4	2 max
		1,778	23,876	6,35	28,194	28,575		440	120,06	22,47	0,11/1,4	0,22 max
22,22	14	0.07	0.940	0.25	1.110	1.125	19	1.11	28880	5 295	2.21/18	4 max
		1,778	23,876	6,35	28,194	28,575		501	128,46	23,55	0,25/2,04	0,46 max
25,4	16	0.07	1.070	0.25	1.688	1.250	21	2.00	60230	9 858	2.21/18	4 max
		1,778	27,178	6,35	42,875	31,750		908	267,92	43,85	0,25/2,04	0,46 max

¹⁾ Loads are valid for rod end bodies made of alloy steel or corrosion resistant steel. For other rod ends, refer to page 292

Cross-reference

Ball bearing rod ends

Metric bearings

3

EN part number		SKF designation
EN3541Ld'EKA		CdMJEGRN741
EN3541Ld'EKB		CdMJEGRN811
EN3541Ld'ETA		CdMJGRN741
EN3541Ld'ETB		CdMJEGRN811
EN3541Ld'PKA		CdMJGRN741
EN3541Ld'PKB		CdMJGRN811
EN3541Ld'PTA		CdMJGRN741
EN3541Ld'PTB		CdMJGRN811
EN3541Rd'EKA		CdMJERN741
EN3541Rd'EKB		CdMJERN811
EN3541Rd'ETA		CdMJERN741
EN3541Rd'ETB		CdMJERN811
EN3541Rd'PKA		CdMJRN741
EN3541Rd'PKB		CdMJRN811
EN3541Rd'PTA		CdMJRN741
EN3541Rd'PTB		CdMJRN811
EN4036Ld'EKA	EN4036Ld'EKAT	XCdMJEGRN741
EN4036Ld'EKB	EN4036Ld'EKBT	XCdMJEGRN811
EN4036Ld'ENA	EN4036Ld'ENAT	XCdMJEGRN741
EN4036Ld'ENB	EN4036Ld'ENBT	XCdMJEGRN811
EN4036Ld'EMA	EN4036Ld'EMAT	XCdMJEGRK2N741
EN4036Ld'EMB	EN4036Ld'EMBT	XCdMJEGRK2N811
EN4036Ld'PKA	EN4036Ld'PKAT	XCdMJGRN741
EN4036Ld'PKB	EN4036Ld'PKBT	XCdMJGRN811
EN4036Ld'PNA	EN4036Ld'PNAT	XCdMJGRN741
EN4036Ld'PNB	EN4036Ld'PNBT	XCdMJGRN811
EN4036Ld'PMA	EN4036Ld'PMAT	XCdMJGRK2N741

EN part number		SKF designation
EN4036Ld'PMB	EN4036Ld'PMBT	XCdMJGRK2N811
EN4036Rd'EKA	EN4036Rd'EKAT	XCdMJERN741
EN4036Rd'EKB	EN4036Rd'EKBT	XCdMJERN811
EN4036Rd'ENA	EN4036Rd'ENAT	XCdMJERN741
EN4036Rd'ENB	EN4036Rd'ENBT	XCdMJERN811
EN4036Rd'EMA	EN4036Rd'EMAT	XCdMJERK2N741
EN4036Rd'EMB	EN4036Rd'EMBT	XCdMJERK2N811
EN4036Rd'PKA	EN4036Rd'PKAT	XCdMJRN741
EN4036Rd'PKB	EN4036Rd'PKBT	XCdMJRN811
EN4036Rd'PNA	EN4036Rd'PNAT	XCdMJRN741
EN4036Rd'PNB	EN4036Rd'PNBT	XCdMJRN811
EN4036Rd'PMA	EN4036Rd'PMAT	XCdMJRK2N741
EN4036Rd'PMB	EN4036Rd'PMBT	XCdMJRK2N811

Where
d = Bore code
d' = 05 for bore code = 5, 06 for bore code = N 6,
 08 for bore code = N 8, 10 for bore code = N10

Example

EN part number		SKF designation
EN3541L 05 EKA		C 5 MJEGRN741
EN4036R 08 PMB	EN4036R 08 PMBT	XCN 8 MJRK2N811
EN4036L 10 EMB	EN4036L 10 EMBT	XCN 10 MJEGRK2N811

Inch bearings

EN part number	SKF designation	
EN4156Ld'EK1AR	WCNdExGKG74	WCNdEx'GK2G74
EN4156Ld'EK2AR	WCNdExGK2G74	WCNdEx'GKG74
EN4156Ld'PK1AR	WCNd-xGKG74	WCNd-x'GK2G74
EN4156Ld'PK2AR	WCNd-xGK2G74	WCNd-x'GKG74
EN4156Rd'EK1AR	WCNdExKG74	WCNdEx'K2G74
EN4156Rd'EK2AR	WCNdExK2G74	WCNdEx'KG74
EN4156Rd'PK1AR	WCNd-xKG74	WCNd-x'K2G74
EN4156Rd'PK2AR	WCNd-xK2G74	WCNd-x'KG74
EN4156Ld'EK1BR	WCNdExGKG81	WCNdEx'GK2G81
EN4156Ld'EK2BR	WCNdExGK2G81	WCNdEx'GKG81
EN4156Ld'PK1BR	WCNd-xGKG81	WCNd-x'GK2G81
EN4156Ld'PK2BR	WCNd-xGK2G81	WCNd-x'GKG81
EN4156Rd'EK1BR	WCNdExKG81	WCNdEx'K2G81
EN4156Rd'EK2BR	WCNdExK2G81	WCNdEx'KG81
EN4156Rd'PK1BR	WCNd-xKG81	WCNd-x'K2G81
EN4156Rd'PK2BR	WCNd-xK2G81	WCNd-x'KG81
EN4156Ld'EK1CR	WCNdExGK	WCNdEx'GK2
EN4156Ld'EK2CR	WCNdExGK2	WCNdEx'GK
EN4156Ld'PK1CR	WCNd-xGK	WCNd-x'GK2
EN4156Ld'PK2CR	WCNd-xGK2	WCNd-x'GK
EN4156Rd'EK1CR	WCNdExK	WCNdEx'K2
EN4156Rd'EK2CR	WCNdExK2	WCNdEx'K
EN4156Rd'PK1CR	WCNd-xK	WCNd-x'K2
EN4156Rd'PK2CR	WCNd-xK2	WCNd-x'K
EN4157Ld'EK1AR	CNdExGK	CNdEx'GK2
EN4157Ld'EK2AR	CNdExGK2	CNdEx'GK
EN4157Ld'PK1AR	CNd-xGK	CNd-x'GK2

EN part number	SKF designation	
EN4157Ld'PK2AR	CNd-xGK2	CNd-x'GK
EN4157Rd'EK1AR	CNdExK	CNdEx'K2
EN4157Rd'EK2AR	CNdExK2	CNdEx'K
EN4157Rd'PK1AR	CNd-xK	CNd-x'K2
EN4157Rd'PK2AR	CNd-xK2	CNd-x'K
EN4157Ld'EK1BR	CNdExGKG81	CNdEx'GK2G81
EN4157Ld'EK2BR	CNdExGK2G81	CNdEx'GKG81
EN4157Ld'PK1BR	CNd-xGKG81	CNd-x'GK2G81
EN4157Ld'PK2BR	CNd-xGK2G81	CNd-x'GKG81
EN4157Rd'EK1BR	CNdExKG81	CNdEx'K2G81
EN4157Rd'EK2BR	CNdExK2G81	CNdEx'KG81
EN4157Rd'PK1BR	CNd-xKG81	CNd-x'K2G81
EN4157Rd'PK2BR	CNd-xK2G81	CNd-x'KG81

Where

d..x = Bore code, except for d..x = 6,35..6 / 7,94..7 and 9,52..9

d..x' = Bore code with d..x' = 6,35..6 / 7,94..7 or 9,52..9

d' = Incremental number from 01 to 07, 10 to 15 and 20 to 24 in the order of bore codes given pages 57 to 62

Example

EN part number	SKF designation
EN4156L 01 EK1AR	WCN 6,35E4 GKG74
EN4157R 10 PK2BR	CN 7,94-5K2 G81

AS part number	SKF designation
MS21151-1GE	SREP 3ML3SK1
MS21151-1G	REP 3ML3SK1
MS21151-1E	SREP 3ML3S181
MS21151-1	REP 3ML3S181
MS21151-2GE	SREP 3MR3SK1
MS21151-2G	REP 3MR3SK1
MS21151-2E	SREP 3MR3S181
MS21151-2	REP 3MR3S181
MS21151-3GE	SREP 3M6ASK1
MS21151-3G	REP 3M6ASK1
MS21151-3E	SREP 3M6AS181
MS21151-3	REP 3M6AS181
MS21151-3CGE	SREP 3MS6ASK1
MS21151-3CG	REP 3MS6ASK1
MS21151-3CE	SREP 3MS6AS181
MS21151-3C	REP 3MS6AS181
MS21151-4GE	SREP 3M6-2NSK1
MS21151-4G	REP 3M6-2NSK1
MS21151-4E	SREP 3M6-2NS181
MS21151-4	REP 3M6-2NS181
MS21151-4CGE	SREP 3MS6-2NSK1
MS21151-4CG	REP 3MS6-2NSK1
MS21151-4CE	SREP 3MS6-2NS181
MS21151-4C	REP 3MS6-2NS181
MS21151-5GE	SREP 3ML6-2NSK1
MS21151-5G	REP 3ML6-2NSK1
MS21151-5E	SREP 3ML6-2NS181
MS21151-5	REP 3ML6-2NS181
MS21151-5CGE	SREP 3MLS6NSK1
MS21151-5CG	REP 3MLS6NSK1
MS21151-5CE	SREP 3MS6NS181
MS21151-5C	REP 3MS6NS181
MS21151-6GE	SRAP 3M4-2SK1
MS21151-6G	RAP 3M4-2SK1
MS21151-6E	SRAP 3M4-2S181
MS21151-6	RAP 3M4-2S181
MS21151-6CGE	SRAP 3MS4-2SK1
MS21151-6CG	RAP 3MS4-2SK1
MS21151-6CE	SRAP 3MS4-2S181
MS21151-6C	RAP 3MS4-2S181
MS21151-7GE	SREP 3M4-6SK1
MS21151-7G	REP 3M4-6SK1
MS21151-7E	SREP 3M4-6S181
MS21151-7	REP 3M4-6S181
MS21151-7CGE	SREP 3MS4-6SK1
MS21151-7CG	REP 3MS4-6SK1
MS21151-7CE	SREP 3MS4-6S181
MS21151-7C	REP 3MS4-6S181

AS part number	SKF designation
MS21151-8GE	SREP 4M6SK1
MS21151-8G	REP 4M6SK1
MS21151-8E	SREP 4M6S181
MS21151-8	REP 4M6S181
MS21151-8CGE	SREP 4M6-4SK1
MS21151-8CG	REP 4M6-4SK1
MS21151-8CE	SREP 4M6-4S181
MS21151-8C	REP 4M6-4S181
MS21151-9GE	SREP 4ML6SK1
MS21151-9G	REP 4ML6SK1
MS21151-9E	SREP 4ML6S181
MS21151-9	REP 4ML6S181
MS21151-9CGE	SREP 4ML6-4SK1
MS21151-9CG	REP 4ML6-4SK1
MS21151-9CE	SREP 4ML6-4S181
MS21151-9C	REP 4ML6-4S181
MS21151-10GE	SREP 5M6SK1
MS21151-10G	REP 5M6SK1
MS21151-10E	SREP 5M6S181
MS21151-10	REP 5M6S181
MS21151-10CGE	SREP 5M6-2SK1
MS21151-10CG	REP 5M6-2SK1
MS21151-10CE	SREP 5M6-2S181
MS21151-10C	REP 5M6-2S181
MS21151-11GE	SREP 5M7SK1
MS21151-11G	REP 5M7SK1
MS21151-11E	SREP 5M7S181
MS21151-11	REP 5M7S181
MS21151-11CGE	SREP 5MS7SK1
MS21151-11CG	REP 5MS7K1
MS21151-11CE	SREP 5MS7S181
MS21151-11C	REP 5MS7S181
MS21151-12GE	SREP 5M10SK1
MS21151-12G	REP 5M10SK1
MS21151-12E	SREP 5M10S181
MS21151-12	REP 5M10S181
MS21151-12CGE	SREP 5MS10SK1
MS21151-12CG	REP 5MS10K1
MS21151-12CE	SREP 5MS10S181
MS21151-12C	REP 5MS10S181
MS21151-13GE	SRAP10M10SK1
MS21151-13G	RAP10M10SK1
MS21151-13E	SRAP10M10S181
MS21151-13	RAP10M10S181
MS21151-13CGE	SRAP10MS10SK1
MS21151-13CG	RAP10MS10K1
MS21151-13CE	SRAP10MS10S181
MS21151-13C	RAP10MS10S181

AS part number	SKF designation	AS part number	SKF designation
MS21153-1GE	SREPB 3NSK1	MS21153-6C	REP 4F5KS181
MS21153-1G	REPB 3NSK1	MS21153-7GE	SREP 4FL5SK1
MS21153-1E	SREPB 3NS181	MS21153-7G	REP 4FL5SK1
MS21153-1	REPB 3NS181	MS21153-7E	SREP 4FL5S181
MS21153-2GE	SREPB 3N-2SK1	MS21153-7	REP 4FL5S181
MS21153-2G	REPB 3N-2SK1	MS21153-7CGE	SREP 4FL5KSK1
MS21153-2E	SREPB 3N-2S181	MS21153-7CG	REP 4FL5KK1
MS21153-2	REPB 3N-2S181	MS21153-7CE	SREP 4FL5KS181
MS21153-3GE	SREP 3F4SK1	MS21153-7C	REP 4FL5KS181
MS21153-3G	REP 3F4SK1	MS21153-8GE	SREP 4F7SK1
MS21153-3E	SREP 3F4S181	MS21153-8G	REP 4F7SK1
MS21153-3	REP 3F4S181	MS21153-8E	SREP 4F7S181
MS21153-4GE	SREP 3FL4SK1	MS21153-8	REP 4F7S181
MS21153-4G	REP 3FL4SK1	MS21153-9GE	SREP 4FL7SK1
MS21153-4E	SREP 3FL4S181	MS21153-9G	REP 4FL7SK1
MS21153-4	REP 3FL4S181	MS21153-9E	SREP 4FL7S181
MS21153-5GE	SREP 3FL4-3SK1	MS21153-9	REP 4FL7S181
MS21153-5G	REP 3FL4-3SK1	MS21153-10GE	SREP 5F5SK1
MS21153-5E	SREP 3FL4-3S181	MS21153-10G	REP 5F5SK1
MS21153-5	REP 3FL4-3S181	MS21153-10E	SREP 5F5S181
MS21153-6GE	SREP 4F5SK1	MS21153-10	REP 5F5S181
MS21153-6G	REP 4F5SK1	MS21153-11GE	SREP 5FL5SK1
MS21153-6E	SREP 4F5S181	MS21153-11G	REP 5FL5SK1
MS21153-6	REP 4F5S181	MS21153-11E	SREP 5FL5S181
MS21153-6CGE	SREP 4F5KSK1	MS21153-11	REP 5FL5S181
MS21153-6CG	REP 4F5KK1		
MS21153-6CE	SREP 4F5KS181		

Self-lubricating spherical plain bearing rod ends

Metric bearings

EN part number		SKF designation
EN2498Ld'K		EMAJdGRK ¹⁾
EN2498Ld'T		EMAJdGR ¹⁾
EN2498Rd'K		EMAJdRK ¹⁾
EN2498Rd'T		EMAJdR ¹⁾
EN4198Ld'K	EN4198Ld'KT	XEMAJdGRK ¹⁾
EN4198Ld'G	EN4198Ld'GT	XEMAJdGR ¹⁾
EN4198Rd'K	EN4198Rd'KT	XEMAJdRK ¹⁾
EN4198Rd'G	EN4198Rd'GT	XEMAJdR ¹⁾

Where
d = Bore code
d' = d with a 0 replacing the space for bore code ≤ 8,
d for bore code = 10
¹⁾ Except for d = 8SP1A

Example

EN part number		SKF designation
EN2498L 08 K		EMAJ 8 GRK
EN4198R 10 G	EN4198R 10 GT	XEMAJ 10 R

Inch bearings

NSA part number		SKF designation
NSA8143-dRK		RdMRK
NSA8143-dR		RdMR
NSA8143-dLK		RdMLK
NSA8143-dL		RdML
NSA 8149-dR (Except for d = 16)		RdFRCS ¹⁾
NSA 8149-dL (Except for d = 16)		RdFLCS ¹⁾
NSA 8149-16R		R 16 FRCS
NSA 8149-16L		R 16 FLCS

Where
d = Bore code
¹⁾ Except for d = 16

Example

EN part number		SKF designation
NSA8143- 03 RK		R 03 MRK
NSA 8149- 10 L		R 10 FLCS

AS part number		SKF designation
M81935/1-dCKL		EMJ/WASdGK
M81935/1-dCK		EMJ/WASdK
M81935/1-dCL		EMJ/WASdG
M81935/1-dC		EMJ/WASd
M81935/1-dKL		MJ/WASdGK
M81935/1-dK		MJ/WASdK
M81935/1-dL		MJ/WASdG
M81935/1-d		MJ/WASd

Where
d = Bore code (multiples of 1/16 inch)

Example

AS part number		SKF designation
M81935/1- 03 CKL		EMJ/WAS 03 GK
M81935/1- 10 K		MJ/WAS 10 K

AS part number	AS designation
M81935/6- d CKL	EPHMJ/WAS d GK
M81935/6- d CK	EPHMJ/WAS d K
M81935/6- d CL	EPHMJ/WAS d G
M81935/6- d C	EPHMJ/WAS d
M81935/6- d KL	PHMJ/WAS d GK
M81935/6- d K	PHMJ/WAS d K
M81935/6- d L	PHMJ/WAS d G
M81935/6- d	PHMJ/WAS d

Where
d = Bore code (multiples of 1/16 inch)

Example

AS part number	SKF designation
M81935/6- 03 CKL	EPHMJ/WAS 03 GK
M81935/6- 10 K	PHMJ/WAS 10 K

AS part number	SKF designation
M81935/8- d CKL	EPHMJ/NAS d GK
M81935/8- d CK	EPHMJ/NAS d K
M81935/8- d CL	EPHMJ/NAS d G
M81935/8- d C	EPHMJ/NAS d
M81935/8- d KL	PHMJ/NAS d GK
M81935/8- d K	PHMJ/NAS d K
M81935/8- d L	PHMJ/NAS d G
M81935/8- d	PHMJ/NAS d

Where
d = Bore code (multiples of 1/16 inch)

Example

AS part number	SKF designation
M81935/8- 03 CKL	EPHMJ/NAS 03 GK
M81935/8- 10 K	PHMJ/NAS 10 K

AS part number	SKF designation
M81935/4- d CKL	EMJ/NAS d GK
M81935/4- d CK	EMJ/NAS d K
M81935/4- d CL	EMJ/NAS d G
M81935/4- d C	EMJ/NAS d
M81935/4- d KL	MJ/NAS d GK
M81935/4- d K	MJ/NAS d K
M81935/4- d L	MJ/NAS d G
M81935/4- d	MJ/NAS d

Where
d = Bore code (multiples of 1/16 inch)

Example

AS part number	SKF designation
M81935/4- 03 CKL	EMJ/NAS 03 GK
M81935/4- 10 K	MJ/NAS 10 K

AS part number	SKF designation
M81935/2- d CKL	EFJ/WAS d GK
M81935/2- d CK	EFJ/WAS d K
M81935/2- d CWL	EFJ/WAS d GW
M81935/2- d CW	EFJ/WAS d W
M81935/2- d CL	EFJ/WAS d G
M81935/2- d C	EFJ/WAS d
M81935/2- d KL	FJ/WAS d GK
M81935/2- d K	FJ/WAS d K
M81935/2- d WL	FJ/WAS d GW
M81935/2- d W	FJ/WAS d W
M81935/2- d L	FJ/WAS d G
M81935/2- d	FJ/WAS d

Where
d = Bore code (multiples of 1/16 inch)

Example

AS part number	SKF designation
M81935/2- 03 CKL	EFJ/WAS 03 GK
M81935/2- 10 W	FJ/WAS 10 W

3 Self-lubricating spherical plain bearing rod end

3

NSA part number	SKF designation
M81935/7- d CKL	EPHFJ/WAS d GK
M81935/7- d CK	EPHFJ/WAS d K
M81935/7- d CWL	EPHFJ/WAS d GW
M81935/7- d CW	EPHFJ/WAS d W
M81935/7- d CL	EPHFJ/WAS d G
M81935/7- d C	EPHFJ/WAS d
M81935/7- d KL	PHFJ/WAS d GK
M81935/7- d K	PHFJ/WAS d K
M81935/7- d WL	PHFJ/WAS d GW
M81935/7- d W	PHFJ/WAS d W
M81935/7- d L	PHFJ/WAS d G
M81935/7- d	PHFJ/WAS d

Where
d = Bore code (multiples of 1/16 inch)

Example

AS part number	SKF designation
M81935/7- 03 CKL	EPHFJ/WAS 03 GK
M81935/7- 10 W	PHFJ/WAS 10 W

NSA part number	SKF designation
M81935/9- d CKL	EPHFJ/NAS d GK
M81935/9- d CK	EPHFJ/NAS d K
M81935/9- d CWL	EPHFJ/NAS d GW
M81935/9- d CW	EPHFJ/NAS d W
M81935/9- d CL	EPHFJ/NAS d G
M81935/9- d C	EPHFJ/NAS d
M81935/9- d KL	PHFJ/NAS d GK
M81935/9- d K	PHFJ/NAS d K
M81935/9- d WL	PHFJ/NAS d GW
M81935/9- d W	PHFJ/NAS d W
M81935/9- d L	PHFJ/NAS d G
M81935/9- d	PHFJ/NAS d

Where
d = Bore code (multiples of 1/16 inch)

Example

AS part number	SKF designation
M81935/9- 03 CKL	EPHFJ/NAS 03 GK
M81935/9- 10 W	PHFJ/NAS 10 W

AS part number	SKF designation
M81935/5- d CKL	EFJ/NAS d GK
M81935/5- d CK	EFJ/NAS d K
M81935/5- d CWL	EFJ/NAS d GW
M81935/5- d CW	EFJ/NAS d W
M81935/5- d CL	EFJ/NAS d G
M81935/5- d C	EFJ/NAS d
M81935/5- d KL	FJ/NAS d GK
M81935/5- d K	FJ/NAS d K
M81935/5- d WL	FJ/NAS d GW
M81935/5- d W	FJ/NAS d W
M81935/5- d L	FJ/NAS d G
M81935/5- d	FJ/NAS d

Where
d = Bore code (multiples of 1/16 inch)

Example

AS part number	SKF designation
M81935/5- 03 CKL	EFJ/NAS 03 GK
M81935/5- 10 W	FJ/NAS 10 W

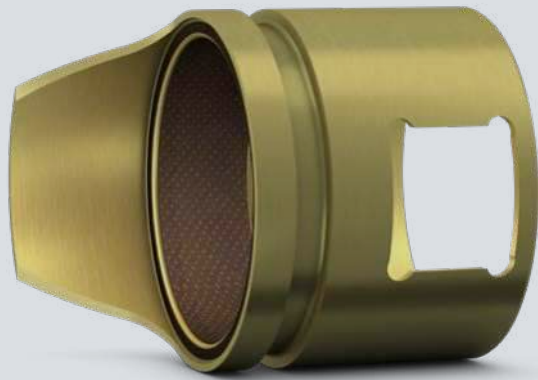

Self-lubricating journal bearings



4 Self-lubricating journal bearings

Designs and variants	392	Product tables	404
Shell materials	392	Metric dimensions	404
Surface treatments	392	4.1 Plain bearings, EN 2285 and 2287	404
Liners	392	4.2 Plain bearings,	406
Customized bearings	392	4.3 Flanged bearings, EN 2286 and EN 2288	408
Bearing selection process	394	4.4 Flanged bearings	410
Selecting bearing size and options	394	Inch dimensions	412
Load carrying capability	394	4.5 Plain bearings, NSA 8145, NSA 8146	412
Static load limits	394	4.6 Plain bearings, AS 81934/1	414
Dynamic load rating	394	4.7 Plain bearings, EN 4534-2 and EN 4536-2	416
Bearing life	394	4.8 Flanged bearings, NSA 8147, NSA 8148	418
Friction and torque	394	4.9 Flanged bearings, AS 81934/2	420
Operating temperature	394	4.10 Flanged bearings, EN 4535-2 and EN 4537-2, code U	422
Selecting fit	396	Cross-reference	426
Fits and tolerances	396	Metric bearings	426
Counterface surfaces	396	Inch bearings	426
Metric bearings	397		
Inch bearings	398		
Bearing data	401		
Material	401		
Surface treatments	401		
Bearing handling	402		
Lubrication	402		
Mounting	402		
Interference fit	402		
Retaining compound	402		
Dismounting	402		
Storage	402		
Customized products	403		
Legacy products	403		
Legacy standards	403		
Customer standards	403		

4 Self-lubricating journal bearings

Journal bearings enable low friction rotation and/or axial sliding of a shaft. They provide a lubricated and wear-resistant surface and enable stable positioning of the guided shaft. If wear in the journal bearing reaches specification limits, the bearing can be replaced without requiring replacement of the surrounding housing structure.

Self-lubricating journal bearings are "maintenance-free" and can accommodate some misalignment between the housing and the shaft. They also prevent fretting between mating parts.

Flanged journal bearings are typically used when axial load carrying capability is needed.

Self-lubricating journal bearings are used widely in aircraft structures. They can be found in many applications including:

- Landing gears
- Flight controls
- Actuators, attachment points and hinges
- Doors
- Helicopter rotors

Designs and variants

The standard assortment of SKF self-lubricating journal bearings is comprised of:

- Plain and flanged bearings
- Two shell materials: corrosion-resistant steel and aluminium alloy
- Two liner types based on reinforced PTFE composites
- A wide range of bore diameters and lengths

SKF manufactures journal bearings complying with international and customer-specific standards. Available product ranges are provided in **table 1** for metric bearings and in **table 2** for inch bearings.

Shell materials

Standard shell materials are:

- corrosion-resistant steel for high load carrying capacity and elevated operating temperatures
- aluminium alloy for lightweight solutions

SKF also supplies customized journal bearings using various other material types and grades, e.g. titanium, 15–5 PH.

For more information and options, refer to *Shell* **page 401**.

Surface treatments

Surface treatments are used to adapt to various application requirements, providing:

- Enhanced corrosion resistance
- Reduced fretting damage

SKF standard surface treatments are passivation for steel and sulfuric acid anodizing for aluminium alloy. For more information and options, refer to *Surface treatments* **page 401**.

Liners

The standard liner types are X1 and Fiberslip:

- X1 demonstrates superior wear characteristics in the majority of applications.
- Fiberslip is more suitable for sliding against softer counterfaces.

In addition, the Textilub liner type is an available customized option for improved performance in specific applications.

For more information, refer to *Liners* **page 401**.

Customized bearings

SKF supplies customized journal bearings to meet specific application requirements. These solutions are the result of SKF's extensive experience and close cooperation between SKF and the customer's application experts. SKF provides total solutions over the full bearing life cycle, including design, testing and partnership.

For more information, refer to *Customized products* **page 403**.

Contact your regional SKF Aerospace partner at: skf.com/go/aero

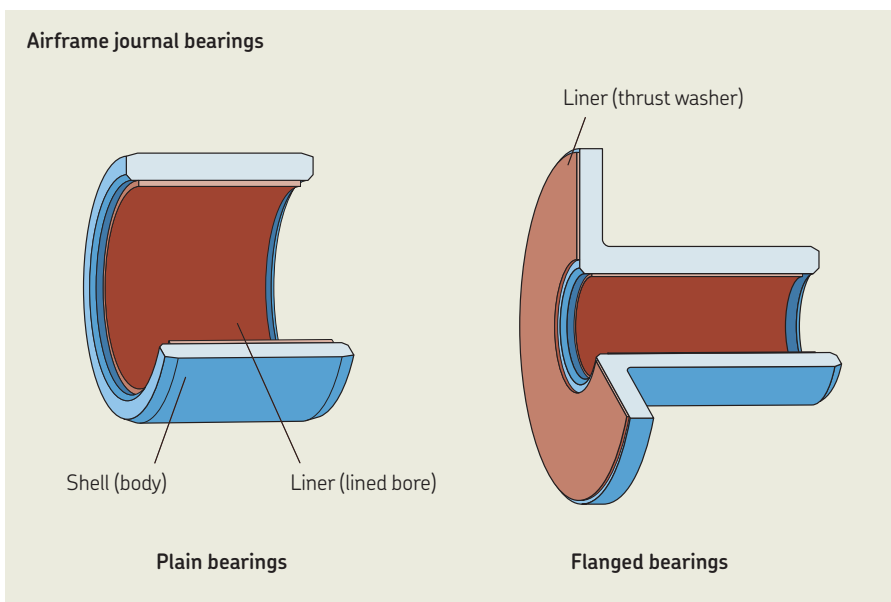

Table 1

SKF self-lubricating journal bearings (metric dimensions)

Shape	Shell material	Standard	Liner	SKF series	Table number	Page
Plain 	Corrosion-resistant steel	EN 2287	X1	13C..Z	4.1	404
		EN 2287	Fiberslip	..K	4.1	404
		–	X1	13D..Z	4.2	406
	Aluminium alloy	EN 2285	X1	13C..Z	4.1	404
		EN 2285	Fiberslip	..K	4.1	404
		–	X1	13D..Z	4.2	406
Flanged 	Corrosion-resistant steel	EN 2288	X1	13C..F	4.3	408
		EN 2288	Fiberslip	..F..K	4.3	408
		–	X1	13D..F	4.4	410
	Aluminium alloy	EN 2286	X1	13C..F	4.3	408
		EN 2286	Fiberslip	..F..K	4.3	408
		–	X1	13D..F	4.4	410

Table 2

SKF self-lubricating journal bearings (inch dimensions)

Shape	Shell material	Standard	Liner	SKF series	Table number	Page
Plain 	Corrosion-resistant steel	NSA 8145	X1	13A..Z..	4.5	412
		NSA 8145	Fiberslip	K..P	4.5	412
		AS 81934/1	X1	13B..Z..	4.6	414
	Aluminium alloy	EN 4536-2	X1	13E..Z..	4.7	416
		NSA 8146	X1	13A..Z..	4.5	412
		NSA 8146	Fiberslip	K..P	4.5	412
Flanged 	Corrosion-resistant steel	NSA 8147	X1	13A..Z..	4.8	418
		NSA 8147	Fiberslip	K..F..P	4.8	418
		AS 81934/2	X1	13B..F..	4.9	420
	Aluminium alloy	EN 4537-2	X1	13E..F..	4.10	422
		NSA 8148	X1	13A..F..	4.8	418
		NSA 8148	Fiberslip	K..F..P	4.8	418
AS 81934/2	X1	13B..F..	4.9	420		
	EN 4535-2	X1	13E..F..	4.10	422	

Bearing selection process

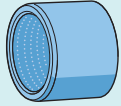
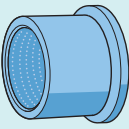
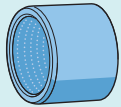
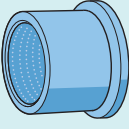
Selecting bearing size and options

If you are looking for a known self-lubricating journal bearing, according to its standard for example, or if you are an experienced bearing expert, use **table 1** and **2** to find the relevant product table.

For help in selecting the appropriate self-lubricating journal bearing size and options, follow these steps:

4

- 1 Determine the range of allowable interface dimensions. Often the boundary dimensions of a bearing are predetermined by the space available on the aircraft system. Typically, the shaft diameter determines the bearing bore diameter.

Determine the radial and axial load requirements. Refer to *Load carrying capability* **page 394**.

- 2 From the product tables (**pages 404 to 425**), find a bearing in an appropriate material with sufficient load carrying capability which best fits the required dimensions

Example

For a plain bearing with a length of 18 mm, to be mounted on a shaft of minimum 20 mm diameter, and into a housing of maximum 26 mm bore diameter, operating under a radial static load of 10 kN, 13D2018AZ aluminium alloy bearing can be selected.

- 3 Choose all other required options, including surface treatments (**page 401**), and refer to fits and counterface recommendations (**page 396**).

If the standard SKF range of self-lubricating journal bearings does not meet your specific needs, contact SKF for a customized design solution, as described in *Customized products* **page 403**.

Load carrying capability

To calculate the load limits of SKF self-lubricating journal bearings, use the formulae provided in **table 3** for metric bearings and **table 4** for inch bearings.

SKF bearings are compliant to AS 81934, AS 81820 and EN 2755. They meet the

requirements of static load, deflection and permanent set, and all dynamic wear limits. For more information about SKF liners including dynamic test performance, refer to *Spherical plain bearings – Load carrying capability* **page 144**. For operating conditions beyond the tested parameters, contact your regional SKF Aerospace partner at: skf.com/go/aero

Static load limits

The compressive strengths of SKF liners are higher than the yield stress of the standard shell materials. Therefore, the static load limit is determined by the yield stress of the shell material.

Dynamic load rating

The radial dynamic load rating, as specified by AS 81934, is the load that a journal bearing can withstand under the following conditions:

- oscillating movement of 25 000 cycles
- oscillating speed ≥ 10 cpm
- wear $\leq 0,114$ mm (0.0045 in)

Bearing life

Bearing life mainly depends on application loads (liner pressure), speed (sliding velocity), and counterface characteristics. Operating temperature and liquid or solid contamination are also important factors for bearing life. For a preliminary check of bearing size in relation to liner pressure and sliding velocity, refer to *Spherical plain bearing – Load carrying capability* **page 144**.

For a bearing life analysis considering relevant parameters, or for customized solutions for individual application requirements, contact your regional SKF Aerospace partner at: skf.com/go/aero

Friction and torque

The friction in self-lubricating journal bearings is determined by the liner and its mating surface under application conditions. For information about the frictional properties of liner materials, refer to *Spherical plain bearings – Friction and torque* **page 146**.

Operating temperature

SKF self-lubricating journal bearings are designed to meet the full temperature requirements of typical aeronautical applications. Their operating temperature is dictated by the temperature limits of the shell material and liner system.

Liner systems can be used at operating temperatures between -55 and $+200$ °C (-67 to $+390$ °F). Immersion into liquid nitrogen at -193 °C (-315 °F) for freeze fitting has no detrimental effect on the liner. For aluminium shell material, the maximum operating temperature is limited to $+120$ °C ($+250$ °F).

When evaluating the suitability of self-lubricating journal bearings for various operating temperatures, the following aspects should be considered:

- Temperature dependent properties of the shell material, refer to *Shell material* **page 401**
- Duration of exposure to the temperature
- Actual load and sliding velocity when exposed to a certain temperature
- Required bearing life

For more information about liner temperature properties, refer to *Spherical plain bearings – Operating temperature* **page 147**.

Table 3

Static load limits and dynamic load ratings, metric values

mm, N and MPa	Radial static load limit	Axial static load limit	Radial dynamic load rating
Plain	$C_s = \frac{3}{4} \sigma_{yield} d (W - 2,5)$	–	$C = 260 d (W - 2,5)$
Flanged	$C_s = \frac{3}{4} \sigma_{yield} d (L - 1,75)$	$C_a = 0,47 \sigma_{yield} ((A - 1,5)^2 - (d + 2,5)^2)$	$C = 260 d (L - 1,75)$

Table 4

Static load limits and dynamic load ratings, inch values

in, lbf and psi	Radial static load limit	Axial static load limit	Radial dynamic load rating
Plain	$C_s = \frac{3}{4} \sigma_{yield} d (W - 0,1)$	–	$C = 37\,500 d (W - 0,1)$
Flanged	$C_s = \frac{3}{4} \sigma_{yield} d (L - 0,07)$	$C_a = 0,47 \sigma_{yield} ((A - 0,06)^2 - (d + 0,1)^2)$	$C = 37\,500 d (L - 0,07)$

4

Bearing dimensions and symbols

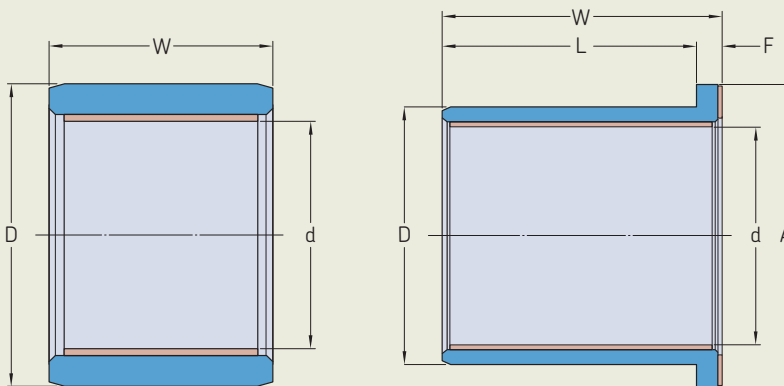

Where:

- A Flange diameter [mm/in]
- L Length to back face of flange [mm/in]
($L = W - F$ [mm/in])
- d Bore diameter [mm/in]
- F Flange width [mm/in]
- D Outer diameter [mm/in]
- W Overall width [mm/in]
- C_a Axial static load limit [N/lbf]
- C_s Radial static load limit [N/lbf]
- C Radial dynamic load rating [N/lbf]
- σ_{yield} Yield stress of shell material [MPa/psi] (table 5)

Table 5

Yield stresses of shell material

Material	Yield stress σ_{yield}	
	MPa	psi
–		
17-4PH H1150	724	105 000
S.80 (FHT)	690	100 050
2618 DTD 5014 TF	340	49 300
2024 T851	400	58 000
2024 T8511	400	58 000

Selecting fit

To use the full load carrying capability of a bearing, it must be fully supported by the shaft and the housing.

Fits and tolerances

Journal bearings are typically interference fitted into their housing or a retaining compound can be used between the journal bearing and housing to maintain the bearing in position. When interference fitted, the installed lined bore size is reduced accordingly. Suitable housing and shaft diameter ranges are provided in **tables 6 to 9, pages 397 to 400**.

4

Counterface surfaces

It is recommended to use a hard surface as a counterface to the liner. Typical solutions are listed below. For softer counterfaces Fiberslip liner should be used. See also NOTE regarding very soft surfaces.

Steel

Hardened steel is the preferred counterface material for the standard self-lubricating journal bearing liners. It is recommended that steel shaft surfaces comply to the following specifications:

- Surface roughness $R_a \leq 0,1 \mu\text{m}$ (4 $\mu\text{in.}$)
- Hardness ≥ 56 HRC

Softer steel counterfaces can be used but with implications on the liner wear rate. A suitable coating can be applied to achieve the required hardness. Refer to *Customized products* **page 403** and contact SKF.

Aluminium alloy

Aluminium alloy counterface surfaces should be hard anodized. Using aluminium instead of steel can reduce bearing life.

Titanium alloy

Titanium alloy counterface surfaces should have a hard surface treatment applied to provide suitable surface properties. Hard chromium plating or similar coating can provide suitable surface properties.

NOTE: Very soft surfaces such as paint films, dry-film lubricants, cadmium or zinc-nickel plating are not suitable as counterface surfaces for the self-lubricating journal bearing liners.

Metric bearings

Table 6

Housing and shaft tolerances by type of fit

Series: ..K, 13C..Z
13D..Z
..F..K, 13C..F
13D..F

Nominal bore Code	Interference fit in housing						Nominal bore Code	Adhesive bonding to housing					
	Housing diameter		Shaft diameter					Housing diameter		Shaft diameter			
	Upper	Lower	Transition fit		Loose fit			Upper	Lower	Transition fit		Loose fit	
–	mm		mm				–	mm		mm			
06	10,015	10,000	6,007	5,999	5,990	5,982	06	10,124	10,074	6,024	6,016	6,004	5,996
08	12,018	12,000	8,007	7,998	7,987	7,978	08	12,129	12,079	8,025	8,016	8,005	7,996
10	14,018	14,000	10,007	9,998	9,987	9,978	10	14,129	14,079	10,025	10,016	10,005	9,996
12	16,018	16,000	12,008	11,997	11,984	11,973	12	16,129	16,079	12,026	12,015	12,006	11,995
15	19,021	19,000	15,008	14,997	14,984	14,973	15	19,135	19,085	15,026	15,015	15,006	14,995
16	20,021	20,000	16,008	15,997	15,984	15,973	16	20,135	20,085	16,026	16,015	16,006	15,995
18	22,021	22,000	18,008	17,997	17,984	17,973	18	22,135	22,085	18,026	18,015	18,006	17,995
20	25,021	25,000	20,009	19,996	19,980	19,967	20	25,135	25,085	20,027	20,014	20,007	19,994
22	26,021	26,000	22,009	21,996	21,980	21,967	22	26,135	26,085	22,027	22,014	22,007	21,994
25	30,021	30,000	25,009	24,996	24,980	24,967	25	30,135	30,085	25,027	25,014	25,007	24,994
28	34,025	34,000	28,009	27,996	27,980	27,967	28	34,142	34,092	28,027	28,014	28,007	27,994
30	36,025	36,000	30,009	29,996	29,980	29,967	30	36,142	36,092	30,027	30,014	30,007	29,994
32	38,025	38,000	32,011	31,995	31,975	31,959	32	38,142	38,092	32,029	32,013	32,009	31,993
35	42,025	42,000	35,011	34,995	34,975	34,959	35	42,142	42,092	35,029	35,013	35,009	34,993
40	48,025	48,000	40,011	39,995	39,975	39,959	40	48,142	48,092	40,029	40,013	40,009	39,993
45	52,030	52,000	45,011	44,995	44,975	44,959	45	52,151	52,101	45,029	45,013	45,009	44,993
50	58,030	58,000	50,011	49,995	49,975	49,959	50	58,151	58,101	50,029	50,013	50,009	49,993

Inch bearings

Table 7

Housing and shaft tolerances by type of fit

Series: K..P
K..F..P
13A..F..
13A..Z..

Interference fit in housing

Adhesive bonding to housing

Nominal bore	Housing diameter		Shaft diameter				Nominal bore	Housing diameter		Shaft diameter					
	Code	Size	Upper	Lower	Transition fit			Loose fit		Code	Upper	Lower	Transition fit		Loose fit
–	in/mm	in/mm	in/mm		in/mm		–	in/mm	in/mm	in/mm		in/mm		in/mm	
04	1/4	0.3754	0.3750	0.2500	0.2496	0.2495	0.2491	04	0.3800	0.3780	0.2511	0.2507	0.2503	0.2499	
	6,350	9,535	9,525	6,350	6,340	6,337	6,327		9,652	9,601	6,378	6,368	6,358	6,347	
05	5/16	0.4380	0.4375	0.3125	0.3121	0.3120	0.3116	05	0.4426	0.4406	0.3138	0.3134	0.3130	0.3126	
	7,938	11,125	11,113	7,938	7,927	7,925	7,915		11,242	11,191	7,971	7,960	7,950	7,940	
06	3/8	0.5005	0.5000	0.3750	0.3746	0.3745	0.3741	06	0.5051	0.5031	0.3764	0.3760	0.3756	0.3752	
	9,525	12,713	12,700	9,525	9,515	9,512	9,502		12,830	12,779	9,561	9,550	9,540	9,530	
08	1/2	0.6882	0.6875	0.5000	0.4996	0.4994	0.4990	08	0.6928	0.6908	0.5014	0.5010	0.5006	0.5002	
	12,700	17,480	17,463	12,700	12,690	12,685	12,675		17,597	17,546	12,736	12,725	12,715	12,705	
10	5/8	0.8133	0.8125	0.6250	0.6246	0.6244	0.6240	10	0.8179	0.8159	0.6265	0.6261	0.6257	0.6253	
	15,875	20,658	20,638	15,875	15,865	15,860	15,850		20,775	20,724	15,913	15,903	15,893	15,883	
12	3/4	0.9383	0.9375	0.7500	0.7495	0.7492	0.7487	12	0.9429	0.9409	0.7516	0.7511	0.7508	0.7503	
	19,050	23,833	23,813	19,050	19,037	19,030	19,017		23,950	23,899	19,091	19,078	19,070	19,058	
14	7/8	1.0633	1.0625	0.8750	0.8745	0.8742	0.8737	14	1.0680	1.0660	0.8767	0.8762	0.8759	0.8754	
	19,050	27,008	26,988	22,225	22,212	22,205	22,192		27,127	27,076	22,268	22,255	22,248	22,235	
16	1	1.1883	1.1875	1.0000	0.9995	0.9992	0.9987	16	1.1930	1.1910	1.0018	1.0013	1.0010	1.0005	
	25,400	30,183	30,163	25,400	25,387	25,380	25,367		30,302	30,251	25,446	25,433	25,425	25,413	
18	1 1/8	1.3135	1.3125	1.1250	1.1245	1.1242	1.1237	18	1.3183	1.3163	1.1271	1.1266	1.1263	1.1258	
	28,575	33,363	33,338	28,575	28,562	28,555	28,542		33,485	33,434	28,628	28,616	28,608	28,595	
20	1 1/4	1.5010	1.5000	1.2500	1.2494	1.2490	1.2484	20	1.5059	1.5039	1.2520	1.2514	1.2512	1.2506	
	31,750	38,125	38,100	31,750	31,735	31,725	31,709		38,250	38,199	31,801	31,786	31,780	31,765	
22	1 3/8	1.6260	1.6250	1.3750	1.3744	1.3740	1.3734	22	1.6309	1.6289	1.3771	1.3765	1.3763	1.3757	
	34,925	41,300	41,275	34,925	34,910	34,900	34,884		41,425	41,374	34,978	34,963	34,958	34,943	
24	1 1/2	1.7510	1.7500	1.5000	1.4994	1.4990	1.4984	24	1.7539	1.7519	1.5021	1.5015	1.5013	1.5007	
	38,100	44,475	44,450	38,100	38,085	38,075	38,059		44,549	44,498	38,153	38,138	38,133	38,118	
28	1 3/4	2.0012	2.0000	1.7500	1.7494	1.7490	1.7484	28	2.0063	2.0043	1.7525	1.7519	1.7517	1.7511	
	44,450	50,830	50,800	44,450	44,435	44,425	44,409		50,960	50,909	44,514	44,498	44,493	44,478	
32	2	2.2512	2.2500	2.0000	1.9993	1.9988	1.9981	32	2.2563	2.2543	2.0025	2.0018	2.0017	2.0010	
	50,800	57,180	57,150	50,800	50,782	50,770	50,752		57,310	57,259	50,864	50,846	50,843	50,825	

4

Table 8

Housing and shaft tolerances by type of fit

Material : Aluminium alloy
 Series: 13B..Z..
 13B..F..
 13E..F..

Interference fit in housing								Adhesive bonding to housing							
Nominal bore Code	Size	Housing diameter		Shaft diameter				Nominal bore Code	Housing diameter	Shaft diameter					
		Upper	Lower	Transition fit		Loose fit				Transition fit		Loose fit			
–	in/mm	in/mm	in/mm	Upper	Lower	Upper	Lower	–	in/mm	in/mm	Upper	Lower	Upper	Lower	
04	1/4	0.3754	0.3750	0.2495	0.2490	0.2489	0.2484	04	0.3800	0.3780	0.2513	0.2508	0.2505	0.2500	
	6,350	9,535	9,525	6,337	6,325	6,322	6,309		9,652	9,601	6,383	6,370	6,363	6,350	
05	5/16	0.4380	0.4375	0.3120	0.3115	0.3114	0.3109	05	0.4426	0.4406	0.3138	0.3133	0.3130	0.3125	
	7,938	11,125	11,113	7,925	7,912	7,910	7,897		11,242	11,191	7,971	7,958	7,950	7,938	
06	3/8	0.5005	0.5000	0.3745	0.3740	0.3739	0.3734	06	0.5051	0.5031	0.3763	0.3758	0.3755	0.3750	
	9,525	12,713	12,700	9,512	9,500	9,497	9,484		12,830	12,779	9,558	9,545	9,538	9,525	
07	7/16	0.5631	0.5624	0.4365	0.4360	0.4358	0.4353	07	0.5677	0.5657	0.4388	0.4383	0.4380	0.4375	
	11,113	14,303	14,285	11,087	11,074	11,069	11,057		14,420	14,369	11,146	11,133	11,125	11,113	
08	1/2	0.6258	0.6251	0.4990	0.4985	0.4983	0.4978	08	0.6305	0.6285	0.5013	0.5008	0.5005	0.5000	
	12,700	15,895	15,878	12,675	12,662	12,657	12,644		16,015	15,964	12,733	12,720	12,713	12,700	
09	9/16	0.6885	0.6878	0.5615	0.5610	0.5608	0.5603	09	0.6932	0.6912	0.5638	0.5633	0.5630	0.5625	
	14,288	17,488	17,470	14,262	14,249	14,244	14,232		17,607	17,556	14,321	14,308	14,300	14,288	
10	5/8	0.8135	0.8127	0.6240	0.6235	0.6233	0.6228	10	0.8181	0.8161	0.6263	0.6258	0.6255	0.6250	
	15,875	20,663	20,643	15,850	15,837	15,832	15,819		20,780	20,729	15,908	15,895	15,888	15,875	
11	1 1/16	0.8760	0.8752	0.6865	0.6860	0.6858	0.6853	11	0.8806	0.8786	0.6888	0.6883	0.6880	0.6875	
	26,988	22,250	22,230	17,437	17,424	17,419	17,407		22,367	22,316	17,496	17,483	17,475	17,463	
12	3/4	0.9386	0.9378	0.7490	0.7485	0.7482	0.7478	12	0.9432	0.9412	0.7513	0.7508	0.7505	0.7500	
	19,050	23,840	23,820	19,025	19,012	19,004	18,994		23,957	23,906	19,083	19,070	19,063	19,050	
14	7/8	1.0638	1.0630	0.8740	0.8735	0.8732	0.8727	14	1.0684	1.0664	0.8763	0.8758	0.8755	0.8750	
	22,225	27,021	27,000	22,200	22,187	22,179	22,167		27,137	27,087	22,258	22,245	22,238	22,225	
16	1	1.1891	1.1883	0.9990	0.9985	0.9982	0.9978	16	1.1938	1.1918	1.0013	1.0008	1.0005	1.0000	
	25,400	30,203	30,183	25,375	25,362	25,354	25,344		30,323	30,272	25,433	25,420	25,413	25,400	
18	1 1/8	1.3141	1.3131	1.1240	1.1235	1.1232	1.1227	18	1.3189	1.3169	1.1263	1.1258	1.1255	1.1250	
	28,575	33,378	33,353	28,550	28,537	28,529	28,517		33,500	33,449	28,608	28,595	28,588	28,575	
20	1 1/4	1.4390	1.4380	1.2490	1.2484	1.2480	1.2474	20	1.4440	1.4420	1.2513	1.2507	1.2505	1.2499	
	31,750	36,551	36,525	31,725	31,709	31,699	31,684		36,678	36,627	31,783	31,768	31,763	31,747	
22	1 3/8	1.5640	1.5630	1.3740	1.3734	1.3730	1.3724	22	1.5699	1.5679	1.3763	1.3757	1.3755	1.3749	
	34,925	39,726	39,700	34,900	34,884	34,874	34,859		39,875	39,825	34,958	34,943	34,938	34,922	
24	1 1/2	1.7515	1.7505	1.4990	1.4984	1.4980	1.4974	24	1.7544	1.7524	1.5013	1.5007	1.5005	1.4999	
	38,100	44,488	44,463	38,075	38,059	38,049	38,034		44,562	44,511	38,133	38,118	38,113	38,097	
26	1 5/8	1.8765	1.8755	1.6240	1.6234	1.6230	1.6224	26	1.8818	1.8798	1.6263	1.6257	1.6255	1.6249	
	41,275	47,663	47,638	41,250	41,234	41,224	41,209		47,798	47,747	41,308	41,293	41,288	41,272	
28	1 3/4	2.0014	2.0002	1.7480	1.7474	1.7480	1.7474	28	2.0065	2.0045	1.7513	1.7506	1.7505	1.7499	
	44,450	50,836	50,805	44,399	44,384	44,399	44,384		50,965	50,914	44,483	44,465	44,463	44,447	
32	2	2.2514	2.2502	1.9990	1.9983	1.9978	1.9971	32	2.2565	2.2545	2.0013	2.0006	2.0005	1.9998	
	50,800	57,186	57,155	50,775	50,757	50,744	50,726		57,315	57,264	50,833	50,815	50,813	50,795	

4

Housing and shaft tolerances by type of fit

Material : Corrosion-resistant steel
 Series: 13B..Z..
 13B..F..
 13E..F..

Interference fit in housing								Adhesive bonding to housing							
Nominal bore		Housing diameter		Shaft diameter				Nominal bore		Housing diameter		Shaft diameter			
Code	Size	Upper	Lower	Transition fit		Loose fit		Code	Upper	Lower	Transition fit		Loose fit		
–	in/mm	in/mm	in/mm	Upper	Lower	Upper	Lower	–	in/mm	in/mm	Upper	Lower	Upper	Lower	
04	1/4	0.3754	0.3750	0.2500	0.2495	0.2494	0.2489	04	0.3800	0.3780	0.2513	0.2508	0.2505	0.2500	
	6,350	9,535	9,525	6,350	6,337	6,335	6,322		9,652	9,601	6,383	6,370	6,363	6,350	
05	5/16	0.4380	0.4375	0.3125	0.3120	0.3119	0.3114	05	0.4426	0.4406	0.3138	0.3133	0.3130	0.3125	
	7,938	11,125	11,113	7,938	7,925	7,922	7,910		11,242	11,191	7,971	7,958	7,950	7,938	
06	3/8	0.5005	0.5000	0.3750	0.3745	0.3744	0.3739	06	0.5051	0.5031	0.3763	0.3758	0.3755	0.3750	
	9,525	12,713	12,700	9,525	9,512	9,510	9,497		12,830	12,779	9,558	9,545	9,538	9,525	
07	7/16	0.5631	0.5624	0.4370	0.4365	0.4363	0.4358	07	0.5677	0.5657	0.4388	0.4383	0.4380	0.4375	
	11,113	14,303	14,285	11,100	11,087	11,082	11,069		14,420	14,369	11,146	11,133	11,125	11,113	
08	1/2	0.6258	0.6251	0.4995	0.4990	0.4988	0.4983	08	0.6305	0.6285	0.5013	0.5008	0.5005	0.5000	
	12,700	15,895	15,878	12,687	12,675	12,670	12,657		16,015	15,964	12,733	12,720	12,713	12,700	
09	9/16	0.6885	0.6878	0.5620	0.5615	0.5613	0.5608	09	0.6932	0.6912	0.5638	0.5633	0.5630	0.5625	
	14,288	17,488	17,470	14,275	14,262	14,257	14,244		17,607	17,556	14,321	14,308	14,300	14,288	
10	5/8	0.8135	0.8127	0.6245	0.6240	0.6238	0.6233	10	0.8181	0.8161	0.6263	0.6258	0.6255	0.6250	
	15,875	20,663	20,643	15,862	15,850	15,845	15,832		20,780	20,729	15,908	15,895	15,888	15,875	
11	11/16	0.8760	0.8752	0.6870	0.6865	0.6863	0.6858	11	0.8806	0.8786	0.6888	0.6883	0.6880	0.6875	
	26,988	22,250	22,230	17,450	17,437	17,432	17,419		22,367	22,316	17,496	17,483	17,475	17,463	
12	3/4	0.9386	0.9378	0.7495	0.7490	0.7487	0.7482	12	0.9432	0.9412	0.7513	0.7508	0.7505	0.7500	
	19,050	23,840	23,820	19,037	19,025	19,017	19,004		23,957	23,906	19,083	19,070	19,063	19,050	
14	7/8	1.0638	1.0630	0.8745	0.8740	0.8737	0.8732	14	1.0684	1.0664	0.8763	0.8758	0.8755	0.8750	
	22,225	27,021	27,000	22,212	22,200	22,192	22,179		27,137	27,087	22,258	22,245	22,238	22,225	
16	1	1.1891	1.1883	0.9995	0.9990	0.9987	0.9982	16	1.1938	1.1918	1.0013	1.0008	1.0005	1.0000	
	25,400	30,203	30,183	25,387	25,375	25,367	25,354		30,323	30,272	25,433	25,420	25,413	25,400	
18	1 1/8	1.3141	1.3131	1.1245	1.1240	1.1237	1.1232	18	1.3189	1.3169	1.1265	1.1258	1.1255	1.1250	
	28,575	33,378	33,353	28,562	28,550	28,542	28,529		33,500	33,449	28,613	28,595	28,588	28,575	
20	1 1/4	1.4390	1.4380	1.2495	1.2489	1.2485	1.2479	20	1.4440	1.4420	1.2513	1.2507	1.2505	1.2499	
	31,750	36,551	36,525	31,737	31,722	31,712	31,697		36,678	36,627	31,783	31,768	31,763	31,747	
22	1 3/8	1.5640	1.5630	1.3745	1.3739	1.3735	1.3729	22	1.5699	1.5679	1.3763	1.3757	1.3755	1.3749	
	34,925	39,726	39,700	34,912	34,897	34,887	34,872		39,875	39,825	34,958	34,943	34,938	34,922	
24	1 1/2	1.7515	1.7505	1.4995	1.4989	1.4985	1.4979	24	1.7544	1.7524	1.5013	1.5007	1.5005	1.4999	
	38,100	44,488	44,463	38,087	38,072	38,062	38,047		44,562	44,511	38,133	38,118	38,113	38,097	
26	1 5/8	1.8765	1.8755	1.6245	1.6239	1.6235	1.6229	26	1.8818	1.8798	1.6263	1.6257	1.6255	1.6249	
	41,275	47,663	47,638	41,262	41,247	41,237	41,222		47,798	47,747	41,308	41,293	41,288	41,272	
28	1 3/4	2.0014	2.0002	1.7495	1.7489	1.7485	1.7479	28	2.0065	2.0045	1.7513	1.7506	1.7505	1.7499	
	44,450	50,836	50,805	44,437	44,422	44,412	44,397		50,965	50,914	44,483	44,465	44,463	44,447	
32	2	2.2514	2.2502	1.9995	1.9988	1.9983	1.9976	32	2.2565	2.2545	2.0013	2.0006	2.0005	1.9998	
	50,800	57,186	57,155	50,787	50,770	50,757	50,739		57,315	57,264	50,833	50,815	50,813	50,795	

Bearing data

Material

Shell

Corrosion-resistant steel (CRES)

Characteristics:

- High strength
- Good fatigue resistance
- Good corrosion resistance without further treatment
- Mechanical properties stable at elevated temperatures; prolonged operation at temperatures > 120 °C (250 °F) possible

Unless otherwise specified, grades used per the applicable product standards are:

- 17-4PH to AMS5643 H1150 equivalent to EN 3161
- 431 to S.80 (FHT) equivalent to EN 3490

Aluminium alloy

Characteristics:

- Lightweight
- Favourable strength-to-weight ratio
- Corrosion-resistant with surface treatment
- Not suitable for continuous operating temperatures > 120 °C (250 °F)

Unless otherwise specified, grades used per the applicable product standards are:

- 2618 to DTD 5014 TF
- 2024 T3511 to EN 2704 or EN 2318, or 2024 T3 to EN 2701 per applicable EN bearing series
- 2024 to AMS-QQ-A-200/3 T8511 or AMS-QQ-A-225/6 T851 for bearing series other than EN

Refer to the relevant product tables.

Liners

SKF standard high-performance liner types (X1 and Fiberslip) consist of woven PTFE yarns reinforced with structural fibres. The X1-40 liner variant has been qualified to AS 81934, AS 81820 and EN 2755.

For more information, refer to *Spherical plain bearings – Liner* **page 148**.

For detailed information about customized liners such as Textilub, contact your regional SKF Aerospace partner at: skf.com/go/aero

Surface treatments

SKF standard surface treatments are described in **table 10**. For information about other surface treatments, contact your regional SKF Aerospace partner at: skf.com/go/aero

The bearing interface dimensions and tolerances from product tables are not modified when surface treatments are used.

Table 10

Surface treatments			
Shell material	Treatment	Specifications	Characteristics/function
Corrosion-resistant steel	Passivation	AMS2700	<ul style="list-style-type: none"> • enhanced corrosion resistance
	Cadmium ¹⁾ plating	AMS03-19 ²⁾ AMS-QQ-P-416	<ul style="list-style-type: none"> • enhanced corrosion resistance • galvanic corrosion resistance • fretting resistance
	Zinc-nickel plating	AMS2417	<ul style="list-style-type: none"> • enhanced corrosion resistance • galvanic corrosion resistance • fretting resistance
Aluminium alloy	Sulfuric acid anodizing	AMS03-25 ¹⁾³⁾ MIL-A-8625	<ul style="list-style-type: none"> • corrosion resistance

¹⁾ Treatment includes chromium 6 compounds and may be subject to environmental legislation.

²⁾ Formerly DEF STAN 03-19

³⁾ Formerly DEF STAN 03-25

Bearing handling

Lubrication

NOTE: Self-lubricating journal bearings must not be lubricated. Any lubricant can cause detrimental effects to the liner. For example, lubricants can cause stick-slip effects or result in variable frictional properties.

Mounting

Journal bearings can be retained in the housing either by an interference fit or by using a retaining compound between the journal bearing and housing.

Interference fitting is recommended for all situations, except when a lined diameter reduction after installation is not acceptable or when ease of replacement is of primary concern.

Interference fit

Bearings mounted with an interference can be pressed into the housing using a mandrel (figure 1).

A temperature difference between the bearing and housing (e.g. cooling the bearing with liquid nitrogen or refrigeration unit, or heating the housing) is recommended to ease mounting.

To counteract fretting or galvanic corrosion between metallic parts, a jointing compound can be applied.

Retaining compound

Using a retaining compound between the journal bearing and housing allows for a clearance fit between bearing and housing. The effectiveness of the compound used should be tested to confirm its suitability for the application requirements

Dismounting

Journal bearings can be removed from application by pressing them out of their housing using the same mandrel design as recommended for mounting (figure 1).

A dismantled bearing should not be reused. SKF supplies oversized bearings, in a range of increments allowing for the reuse of existing housings.

Storage

SKF self-lubricating journal bearings can be stored for up to 15 years if kept in their original, unopened and undamaged packaging. To fully utilize the maximum storage time, the temperature should be between 15 and 25 °C (60 and 75 °F) and the relative humidity kept in the range of 50 to 70%.

After 15 years of storage, the bearings can be returned to SKF for revalidation.

4

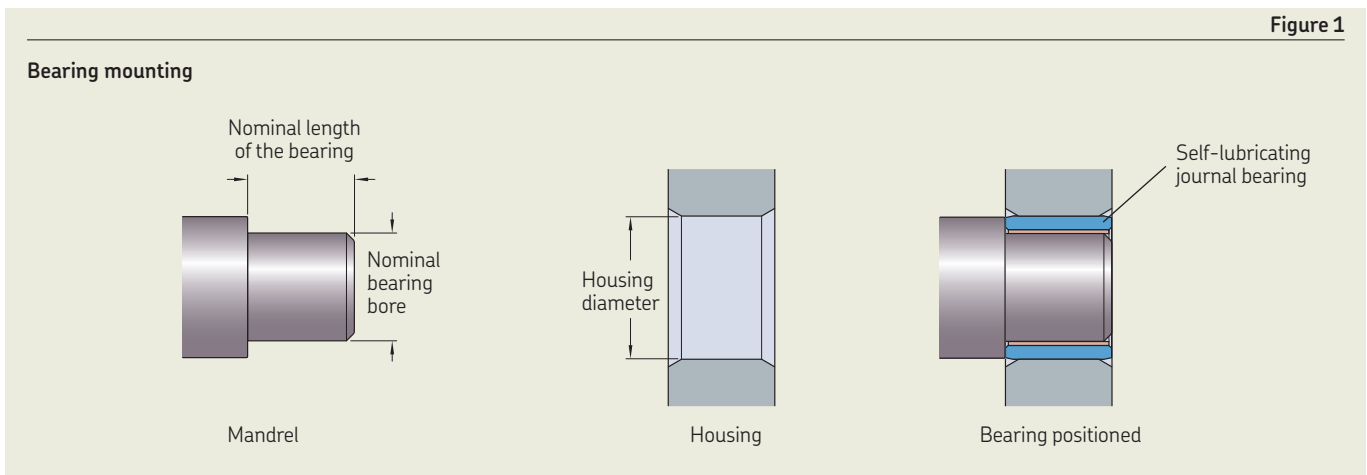

Figure 1

Customized products

SKF designs and manufactures customized journal bearings to meet customer-specific application requirements. Some examples:



General customizations are listed in **table 11**

Legacy products

The following legacy series can still be supplied:

- BCA1..., BCA1..M, BCA2..., BCA2..M
- BLA1..., BLA1..M, BLA2..., BLA2..M
- BFA1..., BFA-C-, BFA2..., BFA-A-
- BPA1..., BPA-C-, BPA2..., BPA-A-
- CDA..., CDA..R
- DJA..., DJA..R

Legacy standards

SKF can supply bearings compliant to the following legacy standards:

- AGS3808, AGS3809, AGS3810, AGS3811
- PAN4832, PAN4833, PAN4834, PAN4835
- BAS7661, BAS7662, BAS7663, BAS7664

Customer standards

Other ranges of standard self-lubricating journal bearings are also available, following customers standards, such as:

- ABS2171 to ABS2174
- ASNA2127 and ASNA2128
- BACB28AB, BACB28AV, BACB28AY, BACB28BF, ...
- NSA 8194 and NSA 8195

Table 11

General customization

- **Geometry**
- **Dimensions**
- **Materials**
 - Alternative corrosion-resistant steels or aluminium alloys
 - Titanium alloys
 - Copper alloys

• Surface treatments

Including:

- Chromic acid anodizing
- Hard chromium plating
- Silver plating
- Hard anodizing
- Dry film lubrication
- Tartaric sulfuric anodizing
- Chemical conversion

Certain treatments include chromium 6 compounds and may be subject to environmental legislation.

Specific customization

- **Retention features**
 - Bolt holes, staked lip, circlip groove, ...
- **Liner type and thickness**
 - Textilub
 - X1
 - Fiberslip
- **Liner location**
- **Double journal bearings (bushpacks)**
- **Additional thrust washers**
- **Unlined journal bearings**

4.1 Plain bearings, EN 2285 and EN 2287 (metric dimensions)

13C..Z, ..K

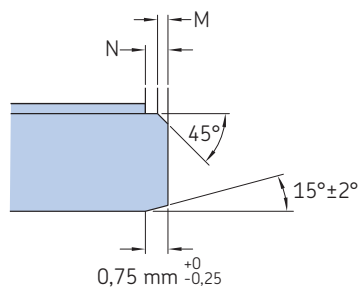
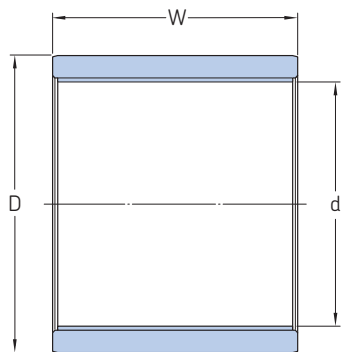

Technical specification	EN 2311
Product standard	EN 2287 (Corrosion-resistant steel) EN 2285 (Aluminium alloy)
Standard materials	
Corrosion-resistant steel:	
13C..Z:	17-4PH
..K:	S.80
Aluminium alloy:	
13C..Z and ..K:	2618 or 2024
Surface treatment: Sulfuric acid anodized	
Liner:	
13C..Z:	X1
..K:	Fiberslip

M	N
mm	
max. 0,5	max. 0,8

Nominal Dimensions bore Code	Length -0,1/-0,4										
	d		D		W						
	Upper	Lower	Upper	Lower	06	08	10	12	15	16	18
-	mm				mm						

06	6,022	6,004	10,024	10,015							
08	8,027	8,005	12,029	12,018							
10	10,027	10,005	14,029	14,018							
12	12,033	12,006	16,029	16,018							
15	15,033	15,006	19,035	19,022							
16	16,033	16,006	20,035	20,022							
18	18,033	18,006	22,035	22,022						1)	
20	20,040	20,007	25,035	25,022						1)	1)
22	22,040	22,007	26,035	26,022						1)	1)
25	25,040	25,007	30,035	30,022						1)	1)
28	28,040	28,007	34,042	34,026						1)	1)
30	30,040	30,007	36,042	36,026						1)	1)
32	32,048	32,009	38,042	38,026						1)	1)
35	35,048	35,009	42,042	42,026							1)
40	40,048	40,009	48,042	48,026							
45	45,048	45,009	52,051	52,032							
50	50,048	50,009	58,051	58,032							

1) SKF option

Designation system

Examples: 13C0806AZY1 13C 06 08 A Z Y1
 13C3025SZC 13C 30 25 S Z C
 1008AKY2 10 08 A K Y2

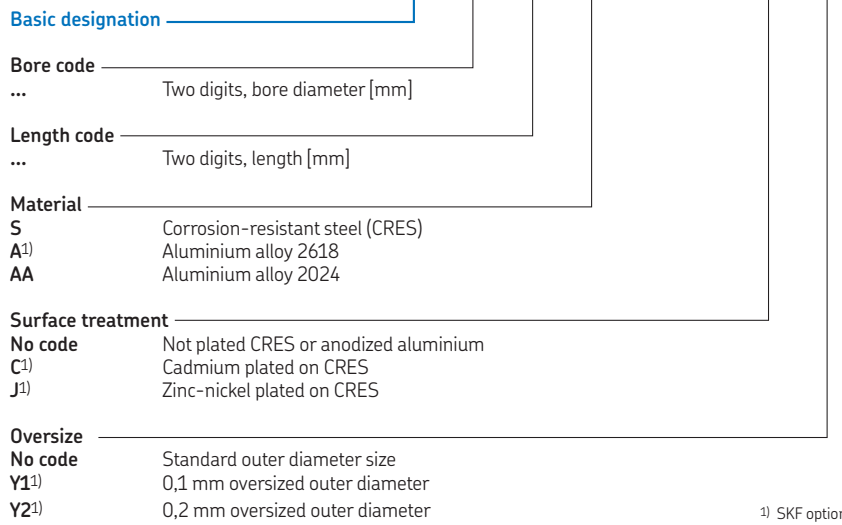

More specifications

Material	391
Surface treatments	391
Liners	391
Load carrying capability	384
Friction and torque	384
Operating temperature	384
Fits and tolerances	386
Counterface surfaces	386
Bearing handling	392

More options and sizes available than the standards offers, see 1).

Customized journal bearings

Contact SKF at skf.com/go/aero

Length -0,1/-0,4

W											Masses	
	20	22	25	28	30	32	35	40	45	50	CRES Per mm length (W)	Aluminium alloy Per mm length (W)
mm											g	

											0,39	0,15
											0,48	0,18
											0,58	0,22
											0,68	0,26
											0,82	0,31
											0,87	0,32
											0,97	0,37
											1,36	0,51
											1,16	0,44
											1,66	0,63
											2,25	0,85
			1)								2,40	0,91
			1)								2,54	0,96
			1)		1)						3,26	1,23
	1)		1)		1)						4,25	1,61
	1)		1)		1)						4,11	1,55
			1)		1)						5,22	1,98

4.2 Plain bearings (metric dimensions)

13D..Z

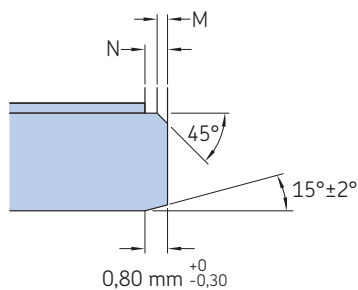
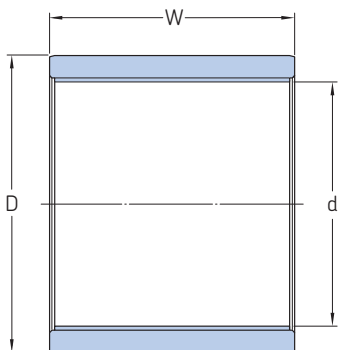

Technical specification

–

Product standard

–

Standard materials

Corrosion-resistant steel:

17-4PH

Surface treatment:

Passivated

Aluminium alloy:

2024

Surface treatment:

Sulfuric acid anodized

Liner:

X1

M	N
mm	
0,45 ^{-0,32}	max. 0,60

4.2

Nominal bore Code	Dimensions				Length –0,1/–0,4						
	d Upper	Lower	D Upper	Lower	W 06	08	10	12	15	18	20
–	mm				mm						
06	6,022	6,004	10,024	10,015							
08	8,027	8,005	12,029	12,018							
10	10,027	10,005	14,029	14,018							
12	12,033	12,006	16,029	16,018							
15	15,033	15,006	19,035	19,022							
16	16,033	16,006	20,035	20,022							
18	18,033	18,006	22,035	22,022							
20	20,040	20,007	25,035	25,022							
22	22,040	22,007	26,035	26,022							
25	25,040	25,007	30,035	30,022							
28	28,040	28,007	34,042	34,026							
30	30,040	30,007	36,042	36,026							
32	32,048	32,009	38,042	38,026							
35	35,048	35,009	42,042	42,026							
40	40,048	40,009	48,042	48,026							
45	45,048	45,009	52,051	52,032							
50	50,048	50,009	58,051	58,032							

Designation system

Examples: 13D0808AZ
13D1215SZCY1

	13D	08	08	A	Z			
	13D	12	15	S	Z	C	Y1	
Basic designation	13D							
Bore code	08							
...	Two digits, bore diameter [mm]							
Length code		08						
...		Two digits, length [mm]						
Material				A				
S	Corrosion-resistant steel (CRES)							
A	Aluminium alloy							
Surface treatment					Z			
No code	Not plated CRES or anodized aluminium							
C	Cadmium plated on CRES							
J	Zinc-nickel plated on CRES							
Oversize							Y1	
No code	Standard outer diameter size							
Y1	0,1 mm oversized outer diameter							
Y2	0,2 mm oversized outer diameter							

More specifications

Material	391
Surface treatments	391
Liners	391
Load carrying capability	384
Friction and torque	384
Operating temperature	384
Fits and tolerances	386
Counterface surfaces	386
Bearing handling	392

Customized journal bearings

Contact SKF at skf.com/go/aero

4.2



Length -0,1/-0,4 W									Masses	
	22	25	28	30	35	40	45	50	CRES Per mm length (W)	Aluminium alloy Per mm length (W)
mm									g	
									0,44	0,18
									0,55	0,22
									0,66	0,26
									0,77	0,31
									0,92	0,37
									0,98	0,40
									1,09	0,44
									1,41	0,56
									1,14	0,46
									1,72	0,68
									2,40	0,94
									2,55	0,99
									2,70	1,05
									2,95	1,54
									4,69	1,78
									4,51	1,72
									5,75	2,18

4.3 Flanged bearings (metric dimensions)

13C..F, ..F..K

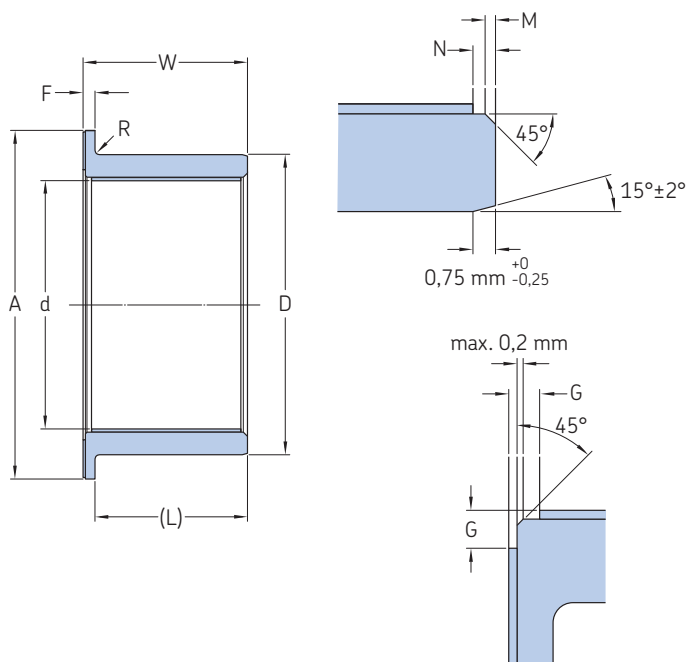

Technical specification	EN 2311
Product standards	EN 2288 (Corrosion-resistant steel) EN 2286 (Aluminium alloy)
Standard materials	
Corrosion-resistant steel:	13C..F: 17-4PH ..F..K: S.80
Aluminium alloy:	13C..F and ..F..K: 2618 or 2024
Surface treatment:	Sulfuric acid anodized
Liner:	13C..F: X1 ..F..K: Fiberslip

Nominal bore code	M	N	R	G
–	mm			
≤ 10	max. 0,5	max. 0,8	0,4 ^{-0,3}	0,90 ^{-0,25}
12 to 18	max. 0,5	max. 0,8	0,75 ^{-0,25}	0,90 ^{-0,25}
≥ 20	max. 0,5	max. 0,8	0,75 ^{-0,25}	1,20 ^{-0,25}

Nominal bore Code	Dimensions						Length $-0,1/-0,4$						
	d Upper	d Lower	D Upper	D Lower	F 0/-0,15	A 0/-0,25	W	06	08	10	12	15	16
–	mm						mm						

06	6,022	6,004	10,024	10,015	1,5	12,0								
08	8,027	8,005	12,029	12,018	1,5	14,0								
10	10,027	10,005	14,029	14,018	1,5	16,0								
12	12,033	12,006	16,029	16,018	1,5	22,0								
15	15,033	15,006	19,035	19,022	1,5	25,0								
16	16,033	16,006	20,035	20,022	1,5	26,0								
18	18,033	18,006	22,035	22,022	1,5	28,0							1)	
20	20,040	20,007	25,035	25,022	1,5	30,0							1)	1)
22	22,040	22,007	26,035	26,022	1,5	32,0							1)	1)
25	25,040	25,007	30,035	30,022	1,5	35,0							1)	1)
28	28,040	28,007	34,042	34,026	2,5	40,0							1)	1)
30	30,040	30,007	36,042	36,026	2,5	42,0							1)	1)
32	32,048	32,009	38,042	38,026	2,5	44,0							1)	1)
35	35,048	35,009	42,042	42,026	2,5	47,0							1)	1)
40	40,048	40,009	48,042	48,026	2,5	52,0								
45	45,048	45,009	52,051	52,032	2,5	57,0								
50	50,048	50,009	58,051	58,032	2,5	62,0								

1) SKF option

Designation system

Examples: 13C0808AFY1 13C 08 08 A F Y1
 13C2020SFC 13C 20 20 S F C
 3220FAKY2 32 20 F A K Y2

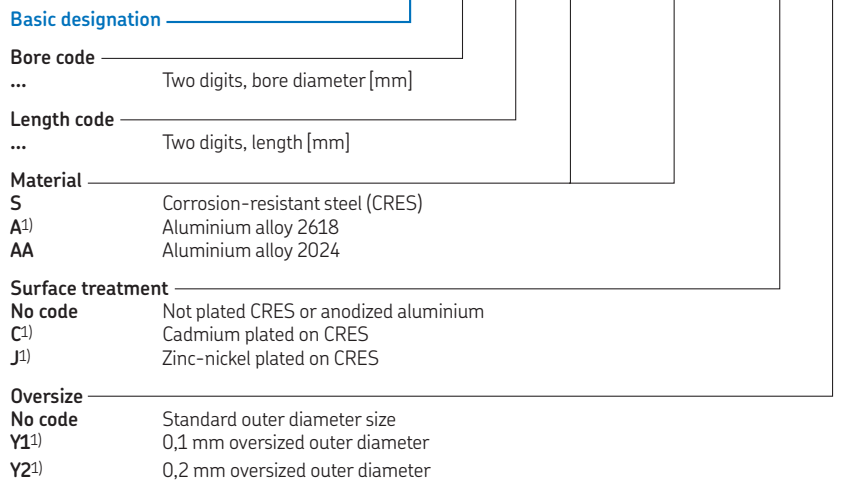

¹⁾ SKF option

More specifications

Material	391
Surface treatments	391
Liners	391
Load carrying capability	384
Friction and torque	384
Operating temperature	384
Fits and tolerances	386
Counterface surfaces	386
Bearing handling	392

More options and sizes available than the standards offers, see 1).

Customized journal bearings

Contact SKF at skf.com/go/aero

Length –0,1/–0,4
 W

20 22 25 28 30 32 35 40 45 50

mm

Masses

CRES	Flange	Aluminium alloy	Flange
Per mm length (L)		Per mm length (L)	

g

Length (mm)	20	22	25	28	30	32	35	40	45	50	CRES Per mm length (L)	Flange	Aluminium alloy Per mm length (L)	Flange
13											0,46	0,44	0,18	0,18
15											0,55	0,55	0,21	0,22
18											0,65	0,66	0,24	0,26
20											0,91	0,77	0,35	0,31
25											1,03	0,92	0,39	0,37
30											1,08	0,98	0,40	0,40
35											1,16	1,09	0,44	0,44
40											1,53	1,41	0,57	0,56
45											1,34	1,14	0,51	0,46
50											1,82	1,72	0,69	0,68
60											2,56	2,40	0,97	0,94
70				1)							2,77	2,55	1,03	0,99
80				1)							2,85	2,70	1,08	1,05
90				1)		1)					3,50	2,95	1,32	1,54
100		1)		1)		1)					4,45	4,69	1,69	1,78
110		1)		1)		1)					4,34	4,51	1,64	1,72
120				1)		1)					5,41	5,75	2,05	2,18

4.4 Flanged bearings (metric dimensions)

13D..F

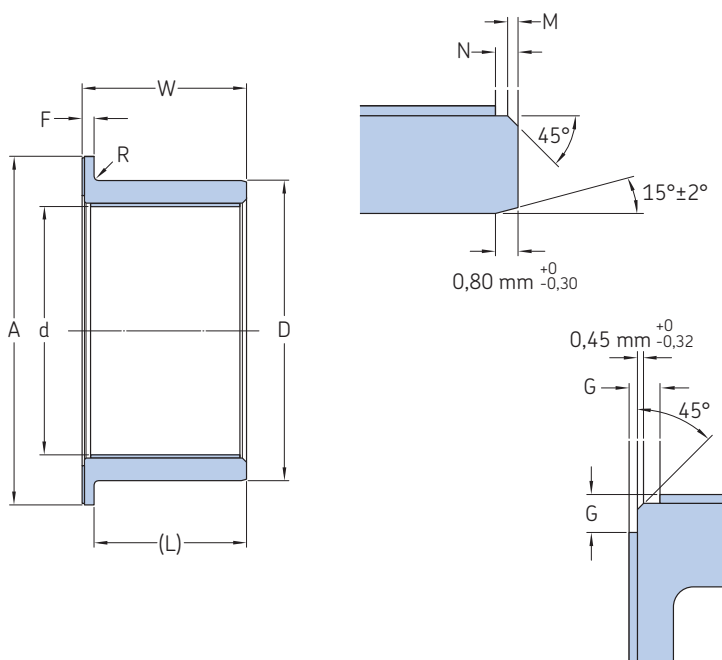

Technical specification

–

Product standards

–

Standard materials

Corrosion-resistant steel:

17-4PH

Surface treatment: Passivated

Aluminium alloy:

2024

Surface treatment: Sulfuric acid anodized

Liner:

X1

M	N	R	G
mm			
0,45 ^{-0,32}	max. 0,60	0,80 ^{-0,30}	1,0 ^{-0,5}

Nominal bore Code	Dimensions		D Upper	Lower	F 0/-0,15	A 0/-0,25	Length -0,1/-0,4					
	d Upper	Lower					06	08	10	12	15	18
–	mm						mm					

06	6,022	6,004	10,024	10,015	1,5	14,0							
08	8,027	8,005	12,029	12,018	1,5	16,0							
10	10,027	10,005	14,029	14,018	1,5	18,0							
12	12,033	12,006	16,029	16,018	1,5	22,0							
15	15,033	15,006	19,035	19,022	1,5	25,0							
16	16,033	16,006	20,035	20,022	1,5	26,0							
18	18,033	18,006	22,035	22,022	1,5	28,0							
20	20,040	20,007	25,035	25,022	1,5	31,0							
22	22,040	22,007	26,035	26,022	1,5	32,0							
25	25,040	25,007	30,035	30,022	1,5	36,0							
28	28,040	28,007	34,042	34,026	2,5	40,0							
30	30,040	30,007	36,042	36,026	2,5	42,0							
32	32,048	32,009	38,042	38,026	2,5	44,0							
35	35,048	35,009	42,042	42,026	2,5	48,0							
40	40,048	40,009	48,042	48,026	2,5	55,0							
45	45,048	45,009	52,051	52,032	2,5	59,0							
50	50,048	50,009	58,051	58,032	2,5	65,0							

Designation system

Examples:	13D0808AFY1	13D	08	08	A	F		Y1
	13D1012SFC	13D	10	12	S	F	C	
	13D3540AFY2	13D	35	40	A	F		Y2

Basic designation	
Bore code	Two digits, bore diameter [mm]
Length code	Two digits, length [mm]
Material	
S	Corrosion-resistant steel (CRES)
A	Aluminium alloy
Surface treatment	
No code	Passivated CRES or sulfuric acid anodised aluminium
C	Cadmium plated on CRES
J	Zinc-nickel plated on CRES
Oversize	
No code	Standard outer diameter size
Y1	0,1 mm oversized outer diameter
Y2	0,2 mm oversized outer diameter

More specifications

Material	391
Surface treatments	391
Liners	391
Load carrying capability	384
Friction and torque	384
Operating temperature	384
Fits and tolerances	386
Counterface surfaces	386
Bearing handling	392

Customized journal bearings

Contact SKF at skf.com/go/aero

Length -0,1/-0,4 W	Length [mm]								Masses [g]				
	20	22	25	28	30	35	40	45	50	CRES Per mm length (L)	Flange	Aluminium alloy Per mm length (L)	Flange
mm													
										0,31	1,47	0,11	0,66
										0,38	1,76	0,14	0,80
										0,46	2,06	0,16	0,93
										0,54	3,12	0,19	1,41
										0,78	3,67	0,28	1,66
										0,82	3,86	0,29	1,74
										0,91	4,23	0,32	1,91
										1,28	5,15	0,46	2,33
										1,10	4,96	0,39	2,24
										1,57	6,16	0,56	2,79
										1,99	12,49	0,71	5,65
										2,12	13,23	0,75	5,98
										2,25	13,96	0,80	6,31
										2,89	16,52	1,03	7,47
										3,77	21,81	1,34	9,86
										3,74	22,29	1,33	10,08
										4,76	26,41	1,69	11,94

4.5 Plain bearings (inch dimensions)

13A..Z..., K..P

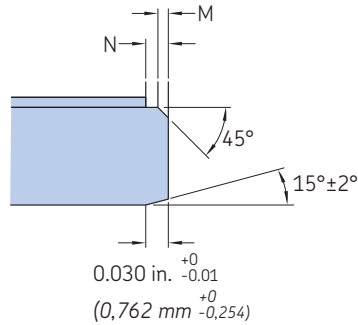
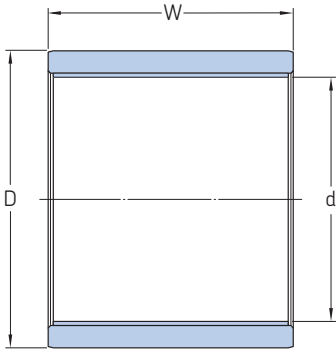

Technical specification	AS 8943
Product standard	NSA 8145 (Corrosion-resistant steel) NSA 8146 (Aluminium alloy)
Standard materials	
Corrosion-resistant steel:	
13A..Z... and K..P:	S.80
Aluminium alloy:	
13A..Z... and K..P:	2618
Surface treatment:	Sulfuric acid anodized
Liner:	
13A..Z...:	X1
K..P:	Fiberslip

Nominal bore code	M		N	
	in/mm			
–				
≤ 12	max. 0.010 max. 0,254	max. 0.025 max. 0,635		
≥ 14	max. 0.020 max. 0,508	max. 0.025 max. 0,635		

Nominal bore	Code	Dimensions		D		Length (W) –0.005/–0.015 (–0,127/–0,381)						
		d		Upper	Lower	5/32	3/16	1/4	5/16	3/8	7/16	1/2
Dia-meter		Upper	Lower	Upper	Lower	3,968 02 ³⁾	4,7625 03	6,35 04	7,935 05	9,525 06	11,115 07	12,7 08
in		in/mm				in/mm						

1/4	04	0.2512 6,401	0.2503 6,358	0.3760 9,550	0.3755 9,538							
5/16	05	0.3139 7,973	0.3130 7,950	0.4386 11,140	0.4381 11,128						2)	
3/8	06	0.3765 9,563	0.3756 9,540	0.5011 12,728	0.5006 12,715						2)	
7/16	07	0.4405 11,188	0.4395 11,164	0.6269 15,924	0.6260 15,900						2)	
1/2	08	0.5016 12,741	0.5006 12,715	0.6888 17,496	0.6883 17,483						2)	
5/8	10	0.6267 15,918	0.6257 15,893	0.8139 20,673	0.8134 20,660						2)	
3/4	12	0.7520 19,101	0.7508 19,070	0.9389 23,848	0.9384 23,835						2)	
7/8	14	0.8771 22,278	0.8759 22,248	1.0640 27,026	1.0635 27,013						2)	
1	16	1.0022 25,456	1.0010 25,425	1.1890 30,201	1.1885 30,188						2)	
1 1/8	18	1.1275 28,639	1.1263 28,608	1.3143 33,383	1.3137 33,368				1)		2)	
1 1/4	20	1.2528 31,821	1.2512 31,780	1.5019 38,148	1.5013 38,133				1)		2)	
1 3/8	22	1.3779 34,999	1.3763 34,958	1.6269 41,323	1.6263 41,308				1)		2)	
1 1/2	24	1.5029 38,174	1.5013 38,133	1.7519 44,498	1.7513 44,483				1)		2)	
1 3/4	28	1.7533 44,534	1.7517 44,493	2.0023 50,858	2.0016 50,841					1)	2)	
2	32	2.0035 50,889	2.0017 50,843	2.2523 57,208	2.2516 57,191					1)	2)	

1) SKF option for corrosion-resistant steel bearings

2) SKF option

3) Code 02 corresponds to a length of 2,5/16 in

Designation system

Examples: 13AAZ0403Y1 13A A Z 04 03 Y1
 13ASZ1012C 13A S Z 10 12 C
 KA0403PY2 K A 04 03 P Y2

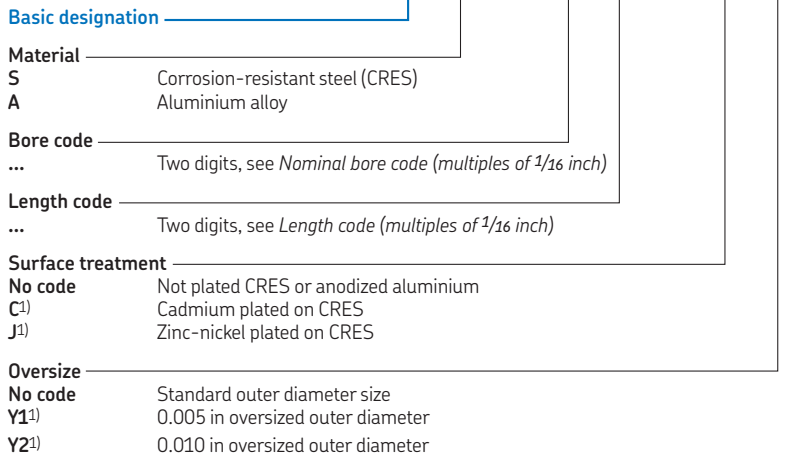

¹⁾ SKF option

More specifications

Material	391
Surface treatments	391
Liners	391
Load carrying capability	384
Friction and torque	384
Operating temperature	384
Fits and tolerances	386
Counterface surfaces	386
Bearing handling	392

More options and sizes available than the standards offers, see 1) and 2).

Customized journal bearings

Contact SKF at skf.com/go/aero

Length (W) –0.005/–0.015 (–0,127/–0,381)									Masses	
5/8	3/4	7/8	1	1 1/4	1 1/2	2	2 1/2	3	CRES	Aluminium alloy
15,88	19,05	22,23	25,5	31,75	38,1	50,8	63,5	76,2	Per inch length (W)	Per inch length (W)
10	12	14	16	20	24	32	40	48	lb/g	

									0.012	0.007
									5,443	3,175
									0.020	0.008
									9,072	3,629
									0.024	0.009
									10,886	4,082
									0.044	0.015
									20,063	6,804
									0.050	0.019
									22,680	8,618
		2)							0.060	0.023
									27,216	10,433
		2)							0.070	0.027
									31,751	12,247
		2)							0.075	0.030
									34,019	13,608
		2)							0.084	0.034
									38,102	15,422
		2)							0.093	0.038
									42,184	17,236
		2)							0.146	0.058
									66,224	26,308
		2)							0.160	0.063
									72,575	28,576
		2)							0.173	0.068
									78,471	30,844
		2)							0.200	0.078
									90,718	35,380
		2)							0.225	0.089
									102,058	40,370

4.6 Plain bearings (inch dimensions)

13B..Z..

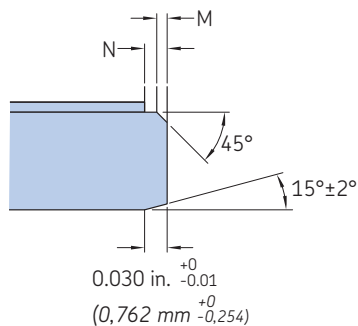
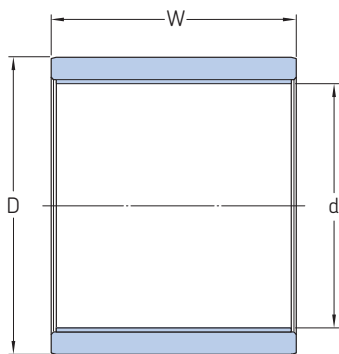

Technical specification AS 81934

Product standard AS 81934/1

Standard materials

Corrosion-resistant steel:

Surface treatment: 17-4PH
Passivated

Aluminium alloy:

Surface treatment: 2024
Sulfuric acid anodized

Liner:

X1

Length code	M	N
–	in/mm	
≤ 12	max. 0.005 max. 0,127	max. 0.010 max. 0,254
≥ 14	max. 0.015 max. 0,381	max. 0.025 max. 0,635

Nominal bore	Code	Dimensions		Length (W) 0/–0.01 0/–0,254													
		d	D	5/32	3/16	7/32	1/4	9/32	5/16	11/32	3/8	7/16	1/2	9/16	5/8	11/16	
Dia-meter		0/–0.0010 0/–0,0254	CRES 0/–0.0005 (0/–0,013) Aluminium alloy ±0.0005 (±0,013)	3,97	4,76	5,56	6,35	7,14	7,94	8,73	9,53	11,11	12,7	14,29	15,88	17,46	
				05	06	07	08	09	10	11	12	14	16	18	20	22	

in in/mm in/mm

1/4	04	0.2515 6,388	0.3760 9,550													
5/16	05	0.3140 7,976	0.4386 11,140													
3/8	06	0.3765 9,563	0.5012 12,730													
7/16	07	0.4390 11,151	0.5638 14,321													
1/2	08	0.5015 12,738	0.6265 15,913													
9/16	09	0.5640 14,326	0.6892 17,506													
5/8	10	0.6265 15,913	0.8142 20,681													
11/16	11	0.6890 17,501	0.8767 22,268													
3/4	12	0.7515 19,088	0.9393 23,858													
7/8	14	0.8765 22,263	1.0645 27,038													
1	16	1.0015 25,438	1.1898 30,221													
1 1/8	18	1.1265 28,613	1.3148 33,396													
1 1/4	20	1.2515 31,788	1.4398 36,571													
1 3/8	22	1.3765 34,963	1.5648 39,746													
1 1/2	24	1.5015 38,138	1.7523 44,508													
1 5/8	26	1.6265 41,313	1.8773 47,683													
1 3/4	28	1.7515 44,488	2.0023 50,858													
2	32	2.0015 50,838	2.2523 57,208													

Designation system

Examples:	13BAZ0406Y1	13B	A	Z	04	06		Y1
	13BSZ1012C	13B	S	Z	10	12	C	
	13BAZ2628Y3	13B	A	Z	26	28		Y3

Basic designation	
Material	
S	Corrosion-resistant steel (CRES)
A	Aluminium alloy
Bore code	
...	Two digits, see <i>Nominal bore code (multiples of 1/16 inch)</i>
Length code	
...	Two digits, see <i>Length code (multiples of 1/32 inch)</i>
Surface treatment	
No code	Passivated CRES or anodized aluminium
C	Cadmium plated on CRES
J	Zinc-nickel plated on CRES
Oversize	
No code	Standard outer diameter size
Y1	0.005 in oversized outer diameter ¹⁾
Y2	0.010 in oversized outer diameter
Y3	0.015 in oversized outer diameter ¹⁾
Y4	0.020 in oversized outer diameter

¹⁾ SKF option

More specifications

Material	391
Surface treatments	391
Liners	391
Load carrying capability	384
Friction and torque	384
Operating temperature	384
Fits and tolerances	386
Counterface surfaces	386
Bearing handling	392

More options available than the standards offers.

Customized journal bearings

Contact SKF at skf.com/go/aero

Length (W) 0/-0.01 0/-0,254																Masses		
3/4	7/8	1	1 1/8	1 1/4	1 3/8	1 1/2	1 5/8	1 3/4	1 7/8	2	2 1/8	2 1/4	2 3/8	2 1/2	2 3/4	3	CRES	Aluminium alloy
19,05	22,23	25,4	28,58	31,75	34,93	38,1	41,28	44,45	47,63	50,8	53,98	57,15	60,33	63,5	69,85	76,2	Per inch length (W)	Per inch length (W)
24	28	32	36	40	44	48	52	56	60	64	68	72	76	80	88	96		

in/mm

lb/g

																	0.016	0.006
																	7,257	2,721
																	0.019	0.007
																	8,618	3,175
																	0.022	0.008
																	9,979	3,629
																	0.025	0.009
																	11,400	4,082
																	0.028	0.011
																	12,700	4,989
																	0.031	0.012
																	14,061	5,443
																	0.056	0.021
																	25,401	9,525
																	0.06	0.022
																	27,215	9,979
																	0.065	0.024
																	29,483	10,886
																	0.075	0.028
																	34,019	12,700
																	0.084	0.031
																	38,102	14,061
																	0.094	0.035
																	42,638	15,876
																	0.103	0.038
																	46,720	17,236
																	0.113	0.041
																	51,256	18,597
																	0.171	0.062
																	77,564	28,123
																	0.183	0.067
																	83,007	30,391
																	0.196	0.071
																	88,904	32,205
																	0.222	0.081
																	100,697	36,741

Designation system

Examples:	13E	A	Z	04	06		Y1
	13E	S	Z	16	36	C	
	13E	A	Z	04	06		Y2

Basic designation	
Material	
S	Corrosion-resistant steel (CRES)
A	Aluminium alloy
Bore code	
...	Two digits, see <i>Nominal bore code (multiples of 1/16 inch)</i>
Length code	
...	Two digits, see <i>Length code (multiples of 1/32 inch)</i>
Surface treatment	
No code	Passivated CRES or anodized aluminium
C ¹⁾	Cadmium plated on CRES
J ¹⁾	Zinc-nickel plated on CRES
Oversize	
No code	Standard outer diameter size
Y1 ¹⁾	0.005 in oversized outer diameter
Y2 ¹⁾	0.010 in oversized outer diameter

¹⁾ SKF option

More specifications

Material	391
Surface treatments	391
Liners	391
Load carrying capability	384
Friction and torque	384
Operating temperature	384
Fits and tolerances	386
Counterface surfaces	386
Bearing handling	392

More options and sizes available than the standards offers, see 1) and 2).

Customized journal bearings

Contact SKF at skf.com/go/aero

Length (W) 0/-0.01 0/-0,254

Length (W) 0/-0.01 0/-0,254																	Masses	
7/8	1	1 1/8	1 1/4	1 3/8	1 1/2	1 5/8	1 3/4	1 7/8	2	2 1/8	2 1/4	2 3/8	2 1/2	2 3/4	3	CRES	Aluminium alloy	
22,23	25,4	28,58	31,75	34,93	38,1	41,28	44,45	47,63	50,8	53,98	57,15	60,33	63,5	69,85	76,2	Per inch length (W)	Per inch length (W)	
28	32	36	40	44	48	52	56	60	64	68	72	76	80	88	96			

in/mm

lb/g

																0,017	0,006
																7,842	2,803
																0,021	0,007
																9,414	3,365
																0,024	0,009
																10,990	3,928
1)																0,028	0,10
																12,571	4,493
1)																0,031	0,011
																14,164	5,062
1)	1)	2)														0,035	0,012
																15,762	5,634
	1)	1)	2)	2)												0,60	0,021
																27,101	9,686
		1)	1)	2)	2)	2)										0,065	0,023
																29,447	10,525
		1)	1)	1)	2)	2)										0,70	0,025
																31,821	11,373
				1)	1)	1)										0,081	0,029
																36,571	13,071
					1)	1)	1)	1)								0,091	0,033
																41,358	14,782
					1)	1)	1)									0,102	0,036
																46,079	16,470
								1)	1)	1)						0,112	0,40
																50,800	18,157
								1)	1)							0,122	0,044
																55,520	19,844
											1)	1)	1)	1)		0,180	0,064
																81,692	29,198
												1)	1)	1)	1)	0,194	0,069
																87,971	31,443
													1)	1)	1)	0,208	0,074
																94,250	33,687
															1)	0,235	0,084
																106,807	38,175

4.8 Flanged bearings (inch dimensions)

13A..F.., K..F..P

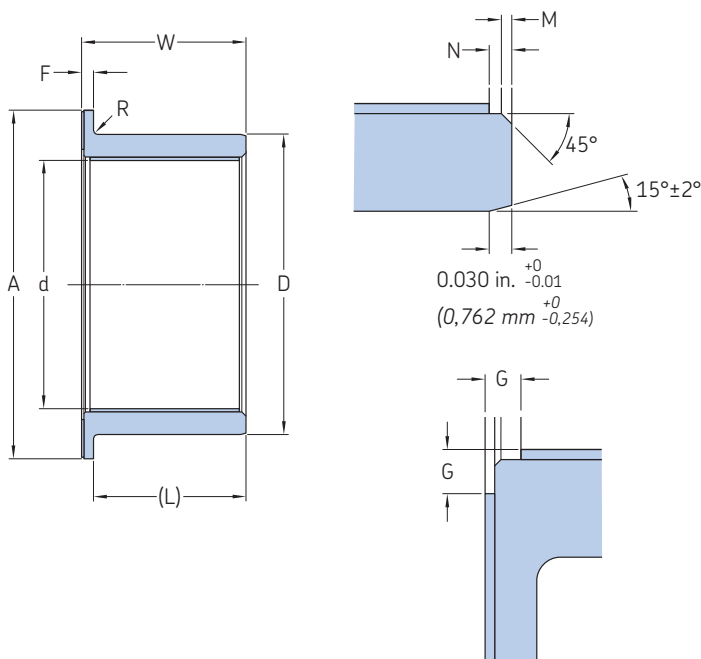

Technical specification AS 8943
Product standards NSA 8147 (Corrosion-resistant steel)
 NSA 8148 (Aluminium alloy)

Standard materials
 Corrosion-resistant steel:
 13A..F.. and K..F..P: S.80
 Aluminium alloy:
 13A..F.. and K..F..P: 2618
 Surface treatment: Sulfuric acid anodized
 Liner:
 13A..F.: X1
 K..F..P: Fiberslip

Nominal bore code	M	N	R	G
-	in/mm			
≤ 12	max. 0.010 max. 0,254	max. 0.025 max. 0,635	0.03 ^{-0,010} 0,762 ^{-0,254}	≈0.020 ≈0,508
≥ 14	max. 0.020 max. 0,508	max. 0.025 max. 0,635	0.03 ^{-0,010} 0,762 ^{-0,254}	≈0.040 ≈1,016

Nominal bore	Dimensions				Length (W) -0.005/-0.015 (-0,127/-0,381)										
	d	D	F	A	5/32	3/16	1/4	5/16	3/8	7/16	1/2				
Code	Upper	Lower	Upper	Lower	0/-0.005	0/-0.010	0/-0.127	0/-0.254	02 ⁴⁾	03	04	05	06	07	08
in	in/mm				in/mm										

1/4	04	0.2512 6,380	0.2503 6,358	0.3760 9,550	0.3755 9,538	0.062 1,6	0.500 12,70		3)	1)					
5/16	05	0.3139 7,973	0.3130 7,950	0.4386 11,140	0.4381 11,128	0.062 1,6	0.562 14,28		3)	1)				3)	
3/8	06	0.3765 9,563	0.3756 9,540	0.5011 12,728	0.5006 12,715	0.062 1,6	0.625 15,87		1)	1)				3)	
7/16	07	0.440 11,188	0.4395 11,164	0.627 15,924	0.626 15,900	0.062 1,6	0.752 19,10			1)				3)	
1/2	08	0.5016 12,741	0.5006 12,715	0.6888 17,496	0.6883 17,483	0.062 1,6	0.875 22,22			1)				3)	
5/8	10	0.6267 15,918	0.6257 15,893	0.8139 20,673	0.8134 20,660	0.062 1,6	1.000 25,40			1)				3)	
3/4	12	0.7520 19,101	0.7508 19,070	0.9389 23,848	0.9384 23,835	0.062 1,6	1.125 28,57			1)				3)	
7/8	14	0.8771 22,278	0.8759 22,248	1.0640 27,026	1.0635 27,013	0.062 1,6	1.250 31,75			1)				3)	
1	16	1.0022 25,456	1.0010 25,425	1.1890 30,201	1.1885 30,188	0.062 1,6	1.375 34,92			1)				3)	
1 1/8	18	1.1275 28,639	1.1263 28,608	1.3143 33,383	1.3137 33,368	0.094 2,4	1.625 41,27				1)			3)	
1 1/4	20	1.2528 31,821	1.2512 31,780	1.5019 38,148	1.5013 38,133	0.094 2,4	1.750 44,45				1)			3)	
1 3/8	22	1.3779 34,999	1.3763 34,958	1.6269 41,323	1.6263 41,308	0.094 2,4	1.875 47,62				1)			3)	
1 1/2	24	1.5029 38,174	1.5013 38,133	1.7519 44,498	1.7513 44,483	0.094 2,4	2.000 50,80				1)			3)	
1 3/4	28	1.7533 44,534	1.7517 44,493	2.0023 50,858	2.0016 50,841	0.094 2,4	2.250 57,15					1)		3)	
2	32	2.0035 50,889	2.0017 50,843	2.2523 57,208	2.2516 57,191	0.094 2,4	2.500 63,50						1)	3)	

1) SKF option for corrosion-resistant steel bearings

2) SKF option for aluminium alloy bearings

3) SKF option

4) Code 02 corresponds to a length of 2,5/16 in

Designation system

Examples: 13AAF0404 13A A F 04 04 Y1
 13ASF1012C 13A S F 10 12 C
 KAF0404PY2 K A F 04 04 P Y2

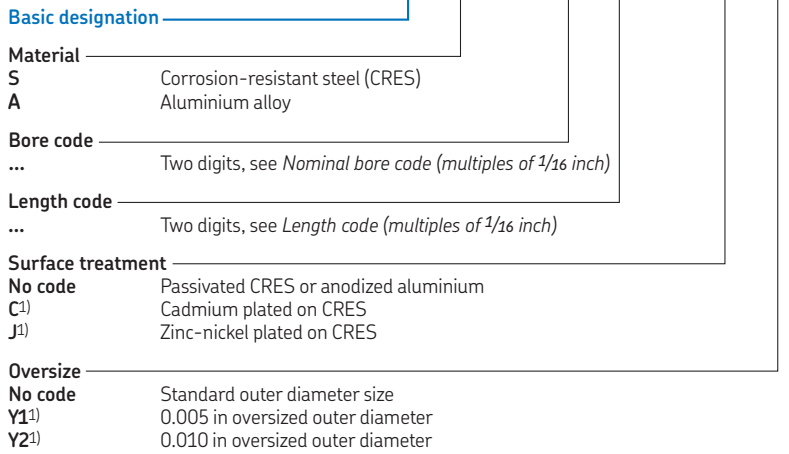

¹⁾ SKF option

More specifications

Material	391
Surface treatments	391
Liners	391
Load carrying capability	384
Friction and torque	384
Operating temperature	384
Fits and tolerances	386
Counterface surfaces	386
Bearing handling	392

More options and sizes available than the standards offers, see 1) to 3).

Customized journal bearings

Contact SKF at skf.com/go/aero

Length (W) –0.005/–0.015 (–0,127/–0,381)

5/8	3/4	13/16	7/8	1	1 1/4	1 1/2	2	2 1/2	3
15,88	19,05	20,64	22,23	25,4	31,75	38,1	50,8	63,5	76,2
10	12	13	14	16	20	24	32	40	48

Masses

CRES	Flange	Aluminium alloy	Flange
Per inch length (L)		Per inch length (L)	

in/mm

lb/g

										0.0132	0.0017	0.0077	0.0006
										5,987	0,771	3,493	0,272
										0.0220	0.0020	0.0088	0.0007
										9,979	0,907	3,992	0,317
										0.0264	0.0022	0.0099	0.0008
										11,975	0,998	4,491	0,363
										0.0340	0.0028	0.0122	0.0010
										15,422	1,270	5,534	0,454
		3)	3)	1)						0.0550	0.0048	0.0209	0.0017
										24,948	2,177	9,480	0,771
		2)	3)		1)					0.0660	0.0056	0.0263	0.0020
										29,937	2,540	11,929	0,907
		3)	3)							0.0770	0.0063	0.0297	0.0023
										34,927	2,858	13,472	1,043
		3)	3)			1)				0.0825	0.0071	0.0330	0.0026
										37,421	3,220	14,969	1,179
		3)	3)							0.0924	0.0078	0.0374	0.0028
										41,912	3,538	16,964	1,270
		3)	3)					3)		0.1023	0.0233	0.0418	0.0084
										46,402	10,569	18,960	3,810
		3)	2)					2)		0.1606	0.0204	0.0638	0.0074
										72,847	9,253	28,939	3,357
		3)	3)							0.1760	0.0220	0.0693	0.0079
										79,832	9,979	31,434	3,583
		3)	3)							0.1903	0.0236	0.0748	0.0085
										86,319	10,705	33,929	3,855
		3)	3)							0.2200	0.0267	0.0858	0.0096
										99,790	12,111	38,918	4,354
		3)	3)							0.2475	0.0299	0.0979	0.0108
										112,264	13,562	44,407	4,899

4.9 Flanged bearings (inch dimensions)

13B..F..

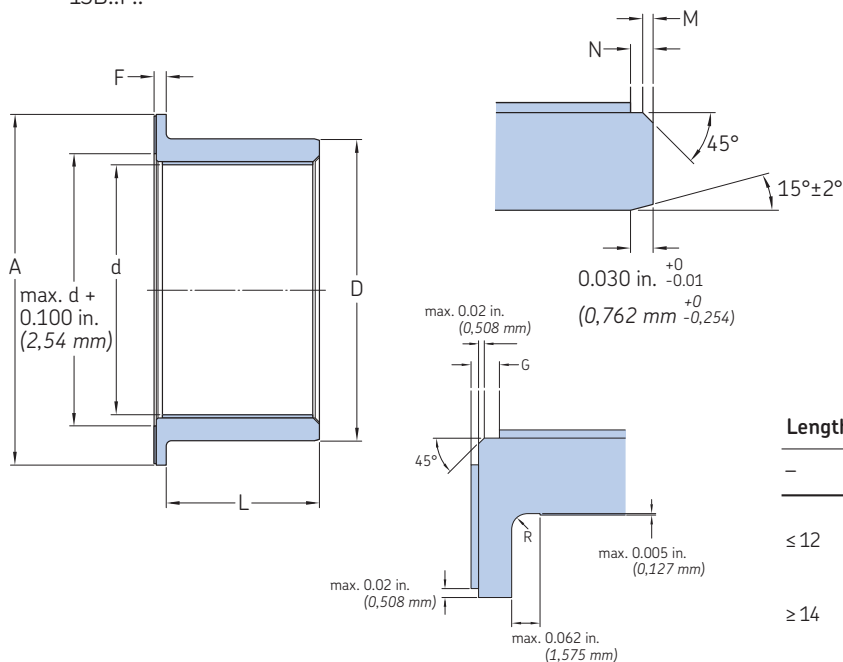

Technical specification	AS 81934
Product standards	AS 81934/2
Standard materials	
Corrosion-resistant steel:	17-4PH
Surface treatment:	Passivated
Aluminium alloy:	2024
Surface treatment:	Sulfuric acid anodized
Liner:	X1

Length code	M	N	R	G
-	in/mm			
≤ 12	max. 0.005 max. 0,127	max. 0.010 max. 0,254	0.010 ±0.005 0,254 ±0,127	max. 0.055 max. 1,397
≥ 14	max. 0.015 max. 0,381	max. 0.025 max. 0,635	0.010 ±0.005 0,254 ±0,127	max. 0.055 max. 1,397

Nominal bore	Dimensions	Length (L) 0/-0.01 0/-0,254														
		d	D	F	A	5/32	3/16	7/32	1/4	9/32	5/16	11/32	3/8	7/16	1/2	9/16
Dia- Code	0/-0.0010 0/-0.0005 ¹⁾	0/-0.005 0/-0.020	0/-0.005 0/-0.020	0/-0.005 0/-0.020	3,97	4,76	5,56	6,35	7,14	7,94	8,73	9,53	11,11	12,7	14,29	15,88
meter	0/-0,0254 0/-0,013	0/-0,127 0/-0,508	0/-0,127 0/-0,508	0/-0,127 0/-0,508	05	06	07	08	09	10	11	12	14	16	18	20

in		in/mm		in/mm													
1/4	04	0.2515 6,388	0.3760 9,550	0.0625 1,587	0.750 19,05												
5/16	05	0.3140 7,976	0.4386 11,140	0.0625 1,587	0.812 20,62												
3/8	06	0.3765 9,563	0.5012 12,730	0.0625 1,587	0.875 22,22												
7/16	07	0.4390 11,151	0.5638 14,321	0.0625 1,587	0.937 23,80												
1/2	08	0.5015 12,738	0.6265 15,913	0.0625 1,587	1.000 25,40												
9/16	09	0.5640 14,326	0.6892 17,506	0.0625 1,587	1.125 28,57												
5/8	10	0.6265 15,913	0.8142 20,681	0.0625 1,587	1.250 31,75												
11/16	11	0.6890 17,501	0.8767 22,268	0.0625 1,587	1.375 34,92												
3/4	12	0.7515 19,088	0.9393 23,858	0.0625 1,587	1.500 38,10												
7/8	14	0.8765 22,263	1.0645 27,038	0.0625 1,587	1.625 41,27												
1	16	1.0015 25,438	1.1898 30,221	0.0625 1,587	1.750 44,45												
1 1/8	18	1.1265 28,613	1.3148 33,396	0.0937 2,380	1.875 47,62												
1 1/4	20	1.2515 31,788	1.4398 36,571	0.0937 2,380	2.000 50,80												
1 3/8	22	1.3765 34,963	1.5648 39,746	0.0937 2,380	2.125 53,97												
1 1/2	24	1.5015 38,138	1.7523 44,508	0.0937 2,380	2.250 57,15												
1 5/8	26	1.6265 41,313	1.8773 47,683	0.0937 2,380	2.375 60,32												
1 3/4	28	1.7515 44,488	2.0023 50,858	0.0937 2,380	2.500 63,50												
2	32	2.0015 50,838	2.2523 57,208	0.0937 2,380	2.750 69,85												

¹⁾ These values apply for corrosion-resistant steel bearings. For aluminium alloy bearings, tolerance is ±0.0005 in (±0,0013 mm)

Designation system

Examples:	13EAF0406UY1	13E	A	F	04	06	U	Y1
	13EAF0406R	13E	A	F	04	06	R	
	13ESF1636UY2	13E	S	F	16	36	U	J Y2

Basic designation	
Material	
S	Corrosion-resistant steel (CRES)
A	Aluminium alloy
Bore code	
...	Two digits, see <i>Nominal bore code (multiples of 1/16 inch)</i>
Length code	
...	Two digits, see <i>Length code (multiples of 1/32 inch)</i>
Geometry	
U	Undercut behind flange
R	Radius behind flange (see page 424)
Surface treatment	
No code	Passivated CRES or anodized aluminium
C ¹⁾	Cadmium plated on CRES ¹⁾
J ¹⁾	Zinc-nickel plated on CRES ¹⁾
Over-size	
No code	Standard outer diameter size
Y1 ¹⁾	0.005 in oversized outer diameter
Y2 ¹⁾	0.010 in oversized outer diameter

¹⁾ SKF option

More specifications

Material	391
Surface treatments	391
Liners	391
Load carrying capability	384
Friction and torque	384
Operating temperature	384
Fits and tolerances	386
Counterface surfaces	386
Bearing handling	392

More options and sizes available than the standards offers, see 1) and 2).

Customized journal bearings

Contact SKF at skf.com/go/aero

Length (W) -0.004/-0.016 -0,10/-0,40																Masses (Code U)			
7/8	1	1 1/8	1 1/4	1 3/8	1 1/2	1 5/8	1 3/4	1 7/8	2	2 1/8	2 1/4	2 3/8	2 1/2	2 3/4	3	CRES	Aluminium alloy		
22,23	25,4	28,58	31,75	34,93	38,1	41,28	44,45	47,63	50,8	53,98	57,15	60,33	63,5	69,85	76,2	Per inch length (L)	Flange	Per inch length (L)	Flange
28	32	36	40	44	48	52	56	60	64	68	72	76	80	88	96				
																0.017	0.0059	0.006	0.0021
																7,842	2,698	2,803	0,965
																0.021	0.0067	0.007	0.0024
																9,414	3,036	3,365	1,086
																0.024	0.0075	0.009	0.0027
																10,990	3,384	3,928	1,211
1)																0.028	0.0082	0.010	0.0029
																12,571	3,724	4,493	1,333
1)																0.031	0.0090	0.011	0.0032
																14,164	4,073	5,062	1,458
1)	1)	1)														0.035	0.0114	0.012	0.0041
																15,762	5,185	5,634	1,855
	1)	1)	1)	2)												0.060	0.0142	0.021	0.0051
																27,101	6,437	9,686	2,303
		1)	1)	1)	2)	2)										0.065	0.0172	0.023	0.0062
																29,447	7,818	10,525	2,797
		1)	1)	1)	1)	2)									0.070	0.0206	0.025	0.0074	
																31,821	9,340	11,373	3,341
				1)	1)	1)							0.081	0.0229	0.029	0.0082			
																36,571	10,382	13,071	3,714
					1)	1)	1)	1)							0.091	0.0252	0.033	0.0090	
																41,358	11,432	14,782	4,090
						1)	1)	1)							0.102	0.0424	0.036	0.0152	
																46,079	19,211	16,470	6,873
							1)	1)	1)						0.112	0.0459	0.040	0.0164	
																50,800	20,828	18,157	7,452
									1)						0.122	0.0495	0.044	0.0177	
																55,520	22,432	19,844	8,026
										1)	1)	1)	1)			0.180	0.0530	0.064	0.0190
																81,692	24,051	29,198	8,606
											1)	1)	1)	1)		0.194	0.0566	0.069	0.0202
																87,971	25,654	31,443	9,180
													1)	1)		0.208	0.0601	0.074	0.0215
																94,250	27,274	33,687	9,759
														1)		0.235	0.0672	0.084	0.0241
																106,807	30,497	38,175	10,913

4.10 Flanged bearings, code R (inch dimensions)

13E..F..

For code U, see page 422

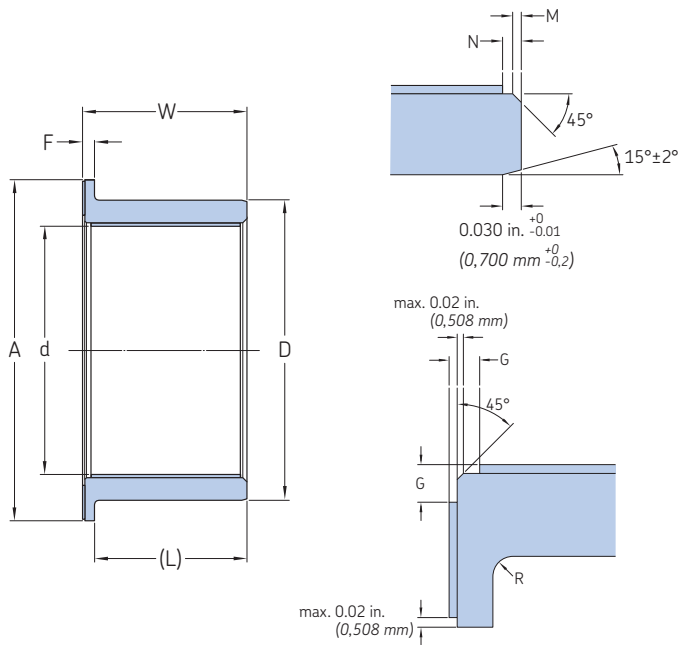

Technical specification	EN 2311
Product standards	EN 4537-2 (Corrosion-resistant steel) EN 4535-2 (Aluminium alloy)
Standard materials	
Corrosion-resistant steel:	17-4PH
Surface treatment:	Passivated
Aluminium alloy:	2024
Surface treatment:	Sulfuric acid anodized
Liner:	X1

Nominal bore code	R	M	N	G
in/mm				
04	0.010 ±0.005 0,25 ±0,13	max. 0.02 max. 0,50	max. 0.03 max. 0,70	max. 0.028 max. 0,70
05	0.020 ±0.005 0,50 ±0,13	max. 0.02 max. 0,50	max. 0.03 max. 0,70	max. 0.028 max. 0,70
06 to 12	0.026 ±0.005 0,65 ±0,13	max. 0.02 max. 0,50	max. 0.03 max. 0,70	max. 0.028 max. 0,70
≥ 14	0.026 ±0.005 0,65 ±0,13	max. 0.02 max. 0,50	max. 0.03 max. 0,70	max. 0.039 max. 1,00

Nominal bore	Dimensions	Length (W) -0.004/-0.016 -0.10/-0.40																
		d	D	F	A (Code R)	3/16	7/32	1/4	9/32	5/16	11/32	3/8	7/16	1/2	9/16	5/8	11/16	3/4
Dia-meter	Code	0/-0.0010 0/-0,0254	0/-0.0005 ³⁾ 0/-0,0127	0/-0.005 0/-0,127	0/-0.020 0/-0,508	4,76	5,56	6,35	7,14	7,94	8,73	9,53	11,11	12,7	14,29	15,88	17,46	19,05
in	in/mm	in/mm																

in	in/mm	d	D	F	A (Code R)	3/16	7/32	1/4	9/32	5/16	11/32	3/8	7/16	1/2	9/16	5/8	11/16	3/4
1/4	04	0.2515 6,388	0.3760 9,550	0.0625 1,587	0.5000 12,700								1)	1)				
5/16	05	0.3140 7,976	0.4386 11,140	0.0625 1,587	0.5630 14,290										1)	1)		
3/8	06	0.3765 9,563	0.5012 12,730	0.0625 1,587	0.6250 15,880											1)	1)	1)
7/16	07	0.4390 11,151	0.5638 14,321	0.0625 1,587	0.7500 19,050												1)	1)
1/2	08	0.5015 12,738	0.6265 15,913	0.0625 1,587	0.8750 22,230													
9/16	09	0.5640 14,326	0.6892 17,506	0.0625 1,587	0.9380 23,820	2)	2)	2)	2)	2)	2)	2)	2)	2)	2)	2)	2)	2)
5/8	10	0.6265 15,913	0.8142 20,681	0.0625 1,587	1.0000 25,400													
11/16	11	0.6890 17,501	0.8767 22,268	0.0625 1,587	1.0630 26,990													
3/4	12	0.7515 19,088	0.9393 23,858	0.0625 1,587	1.1250 28,580													
7/8	14	0.8765 22,263	1.0645 27,038	0.0625 1,587	1.2500 31,750													
1	16	1.0015 25,438	1.1898 30,221	0.0625 1,587	1.3750 34,930													
1 1/8	18	1.1265 28,613	1.3148 33,396	0.094 2,390	1.6250 41,280													
1 1/4	20	1.2515 31,788	1.4398 36,571	0.094 2,390	1.7500 44,450													
1 3/8	22	1.3765 34,963	1.5648 39,746	0.094 2,390	1.8750 47,630													
1 1/2	24	1.5015 38,138	1.7523 44,508	0.094 2,390	2.0000 50,800													
1 5/8	26	1.6265 41,313	1.8773 47,683	0.094 2,390	2.1250 53,980									2)	2)	2)	2)	2)
1 3/4	28	1.7515 44,488	2.0023 50,858	0.094 2,390	2.2500 57,150													
2	32	2.0015 50,838	2.2523 57,208	0.094 2,390	2.5000 63,500													

1) SKF option for corrosion-resistant steel bearings 2) SKF option

3) These values apply for corrosion-resistant steel bearings. For aluminium alloy bearings, tolerance is ±0.0005 in (±0.0013 mm)

Cross-reference

Metric bearings

EN part number	SKF designation	
EN2285-dWAR	dWAAK	13CdWAAZ
EN2286-dWAR	dWFAAK	13CdWAAF
EN2287-dWA	dWWSK	13CdWSZ
EN2288-dW	dWFSK	13CdWSF

Where

d = inner diameter of journal bearing

W = overall width of journal bearing

Example

EN part number	SKF designation	
EN2285-2022AR	2022AAK	13C2022AAZ
EN2288-5040	5040FSK	13C5040SF

AS part number	SKF designation	
M81934/1-dAOW	13BAZdW	
M81934/1-dCOW	13BSZdW	
M81934/1-dCOWP	13BSZdWC	
M81934/1-dCOWE	13BSZdWJ	
M81934/1-dAOWT	13BAZdWY2	
M81934/1-dCOWT	13BSZdWY2	
M81934/1-dCOWPT	13BSZdWCY2	
M81934/1-dCOWET	13BSZdWJY2	
M81934/1-dAOWU	13BAZdWY4	
M81934/1-dCOWU	13BSZdWY4	
M81934/1-dCOWPU	13BSZdWCY4	
M81934/1-dCOWEU	13BSZdWJY4	
M81934/2-dAOL	13BAFdL	
M81934/2-dCOL	13BSFdL	
M81934/2-dCOLP	13BSFdLC	
M81934/2-dCOLE	13BSFdLJ	
M81934/2-dAOLT	13BAFdLY2	
M81934/2-dCOLT	13BSFdLY2	
M81934/2-dCOLPT	13BSFdLCY2	
M81934/2-dCOLET	13BSFdLJY2	
M81934/2-dAOLU	13BAFdLY4	
M81934/2-dCOLU	13BSFdLY4	
M81934/2-dCOLPU	13BSFdLCY4	
M81934/2-dCOLEU	13BSFdLJY4	

Where

d = inner diameter of journal bearing

W = overall width of journal bearing

L = length to back face of flange

Example

AS part number	SKF designation	
M81934/1-08C014	13BSZ0814	
M81934/2-20A032U	13BAF2032Y4	

Inch bearings

EN part number	SKF designation	
EN4534-2VdOW	13EAZdW	
EN4536-2TdOW	13ESZdW	
EN4535-2DdVOW	13EAFdWU	
EN4535-2FdVOW	13EAFdWR	
EN4537-2DdTOW	13ESFdWU	
EN4537-2FdTOW	13ESFdWR	

Where

d = inner diameter of journal bearing

W = overall width of journal bearing

Example

EN part number	SKF designation	
EN4536-2T09006	13ESZ0906	
EN4535-2D04V012	13EAF0412U	

NSA part number	SKF designation	
NSA8145- d-X	KS dWP	13ASZ dW
NSA8146- d-X	KA dWP	13AAZ dW
NSA8147- d-X	KS FdWP	13ASF dW
NSA8148- d-X	KA FdWP	13AAF dW

Where

d = inner diameter of journal bearing

W = overall width of journal bearing

X = $W \times 2$ (except for $W = 02$ where $X = 05$)

Example

NSA part number	SKF designation	
NSA8145- 08-12	KS 0806P	13ASZ 0806
NSA8146- 06-08	KA 0604P	13AAZ 0604



Engineered pulleys



5 Engineered pulleys

Designs and variants	430
Pulley selection process	430
Load carrying capability	431
Lubrication	431
Operating temperature.	431
Internal clearance.	431
Material.	431
Rolling bearings	431
Pulley bodies.	431
Surface treatments.	432
Rolling bearings	432
Pulley bodies.	432
Sealing solutions.	432
Legacy products	432

5 Engineered pulleys

Pulleys are used widely in flight control applications for cable control. They consist of a body and an inserted rolling bearing with a cage.

Pulleys carry loads and enable rotational movements with minimal friction.

5 Designs and variants

Pulleys are made of either a metallic or a non-metallic body and a rolling bearing. The bearing is typically crimped into a metallic ring inserted in the body (**figures 1 and 2**). Pulley bodies can have one or two grooves to accommodate cables (**figure 3**). Bearings used for pulleys are single row or double row deep groove ball bearings with a cage.

Compared to standard full complement airframe bearings as described in *Rolling Bearings* **page 30**, pulley bearings with a cage provide:

- Reduced friction
- Reduced load carrying capability. Refer to *Load carrying capability* **page 431** for more information about the capacity of pulley bearings.

The pulley grooves are designed considering the external diameter of the cables. When coated, consider the cable diameter and the coating thickness.

Pulley selection process

The pulley design, including material, number of bearing rolling elements and number of pulley body grooves, is selected based on load carrying capability requirements, (**page 431**), cable diameter and compactness requirements.

Often the boundary dimensions of a pulley are predetermined by the space available on the aircraft system. Typically, the shaft diameter determines the bearing bore diameter.

Other options including *Lubrication* **page 431**, *Sealing solutions* **page 432**, *Surface treatments* **page 432** and *Internal clearance* **page 431**, are then selected.

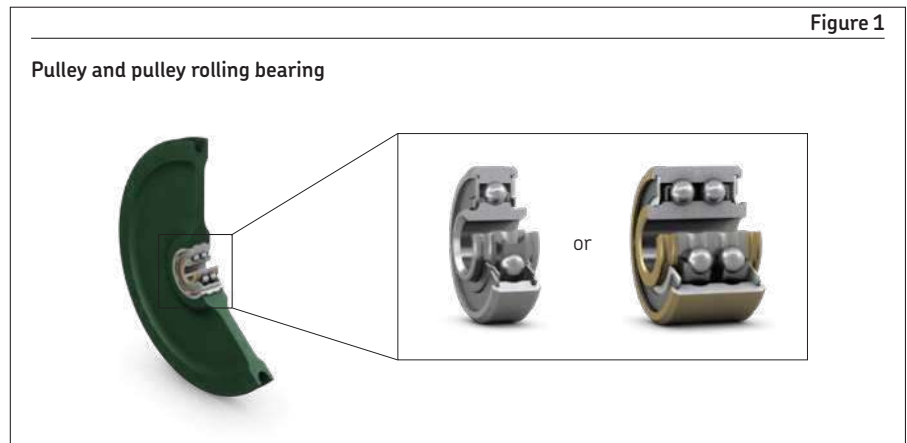

Load carrying capability

Pulleys can sustain static radial loads and dynamic loads.

The load carrying capability of pulleys is described by:

- CE** Endurance dynamic load
- CR** Radial static load of the pulley
- CB** Groove flange strength static load
- CL** Bearing-pulley body bond strength static load

These loads, as defined in AS 7034 (Pulleys, groove, anti-friction bearing, grease lubricated, aircraft, general specification) and EN 2062 (Fully non-metallic body pulleys, with bearings, for control cables technical specification aerospace series), are linked to the cable strengths, which are a function of the cable diameter, cable structure and materials.

Pulleys are designed according to the relevant product standards and tested as per the relevant technical standards.

Contact SKF for more information.

Lubrication

The pulley bearings are lubricated for life and cannot be relubricated. At least 80% of the free space in the bearing is filled with grease. Lubricant details are listed in **table 1**:

Lubrication is primarily chosen according to the operating temperature.

Operating temperature

The permissible operating temperature of pulleys is typically limited by the capability of the grease in the bearing. See **table 1**.

For operation outside this temperature range, bearing life and performance may be reduced. Contact SKF.

Internal clearance

Pulley bearings can be provided with standard or increased internal clearance, as defined in *Rolling bearings – Internal clearance* **page 47**.

Material

Rolling bearings

Bearing rings and rolling elements are either made of bearing steel or corrosion-resistant steel (**table 2**).

Cages are made of light alloy steel.

Pulley bodies

Non-metallic pulley bodies are made of a moulded glass fibre reinforced phenolic compound.

Metallic pulley bodies are made of aluminium alloy (grade 2024 to QQ-A-200/3 T8511).

Crimping rings are typically made of aluminium alloy or light alloy steel.

Contact SKF for other materials.



Surface treatments

Surface treatments are used to increase general corrosion resistance and fretting resistance.

Rolling bearings

Surface treatments are applied to ring surfaces, except raceways and the bore of the inner ring.

Cadmium or zinc-nickel plating can be selected.

- Cadmium plating is applied according to AMS QQP416. It is carried out with or without a chromate treatment following the chosen standard. This treatment can include chromium 6 compounds and may be subject to environmental legislation.
- Zinc-nickel plating is a chromium 6 free alternative to cadmium plating, compliant to environmental legislation. Zinc-nickel plating is applied in accordance with AMS 2417.

Pulley bodies

Metallic pulley bodies are typically protected by sulfuric acid anodizing and a wear-resistant coating in the groove in accordance with the relevant product standards.

Sulfuric acid anodizing complies with AMS03-25 (formerly DEF STAN 03-25) or MIL-A-8625.

SKF can propose other surface treatments for specific purposes.

Sealing solutions

There are two types of bearing sealing solutions to prevent ingress of foreign matter:

- Shield
- Seal

Sealing can increase the starting rotational torque.

Refer to the *Rolling bearings* section **page 30** for more information.

Legacy products

The following legacy series according to their relevant standards can still be supplied:

Metric P., PNA., P..SP., P..MSP..

Metric PN., PA., EN 2081, technical standard EN 2062

Inch P..SP, technical standard AS 7034

Inch PNU 219 ... to PNU 221 ..., MIL-DTL-7034/1 to MIL-DTL-7034/3, technical standard AS 7034

Table 1

Standard greases

NATO codes	Standard	Operating temperature
G354	MIL PRF 23827 type I	-73 to +121 °C (-100 to +250 °F)
G395	MIL PRF 81322	-54 to +177 °C (-64 to +350 °F)

Table 2

Pulley rolling bearing materials

Steel type	Corrosion resistance	Hardness HRC	Material designation	EN standards	AMS standards	Designation
Bearing steel	Moderate	60 to 64	52 100	EN 2031	AMS 6440 or AMS 6444	100Cr6 (100C6)
Corrosion-resistant steel	Good	≥ 58	440C	EN 2030	AMS 5630 or AMS 5618	X105CrMo17 (Z100CD17)

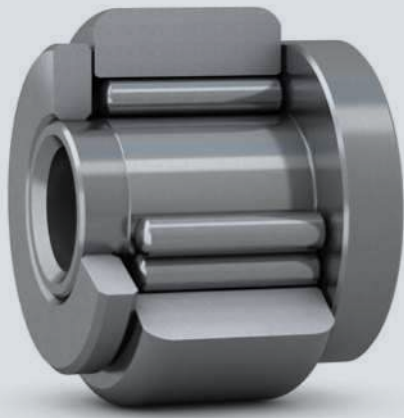

Engineered needle bearings

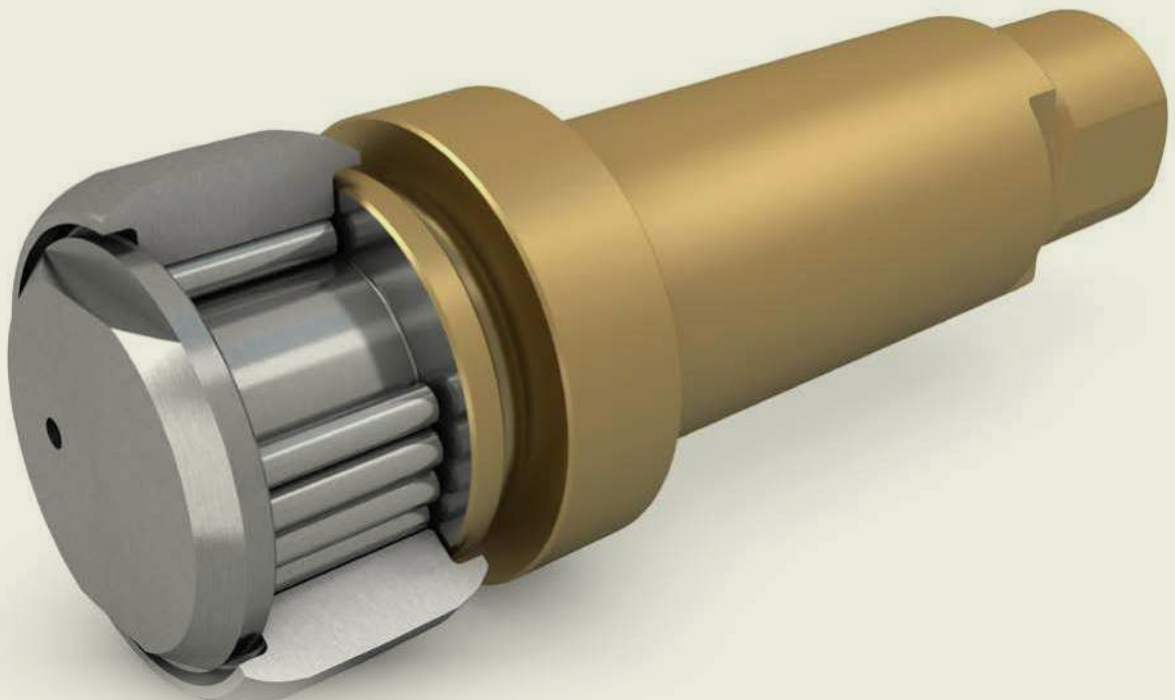

6 Engineered needle bearings

Designs and variants	436
Basic selection process	436
Load carrying capability	436
Lubrication	437
Lubricants	437
Operating temperature	437
Material	437
Surface treatments	437
Mounting	437

6 Engineered needle bearings

Needle bearings are used widely in flight control applications. They are a compact solution that interposes between two elements in translation with respect to each other and enable rotational movements with minimal friction, at relatively low speed.

Designs and variants

SKF supplies needle bearings with:

- An integrated axle – such units are generally referred to as needle track roller bearings, while needle bearings with no integrated axle are referred to as needle roller bearings
- One or two rows of rolling elements

See **figure 1**.

Designs with an integrated axle are typically the most compact solution.

Bearings with a double row of rolling elements typically have a larger load carrying capability than a same size bearing with a single row of rolling elements.

For general information about rolling bearings, refer to *Rolling bearings* chapter **page 30** for more information.

Contact SKF for specific designs, such as track rollers with liners or with cylindrical rollers as rolling elements.

Basic selection process

Needle bearings are selected based on load carrying capability (**page 436**) and compactness.

Often the boundary dimensions of a bearing are predetermined by the space available on the aircraft system. Typically, the shaft diameter determines the bearing bore diameter.

Other options including *Lubrication* **page 437**, *Materials* **page 437** and *Surface treatments* **page 437** are then selected.

Load carrying capability

Needle bearings can accommodate static and dynamic radial loads, as defined in *Rolling bearings – Load carrying capabilities* **page 37**.

Bearing life depends on many parameters, such as load, speed, oscillation angle, lubrication and environmental conditions.

Contact SKF for more information.

6

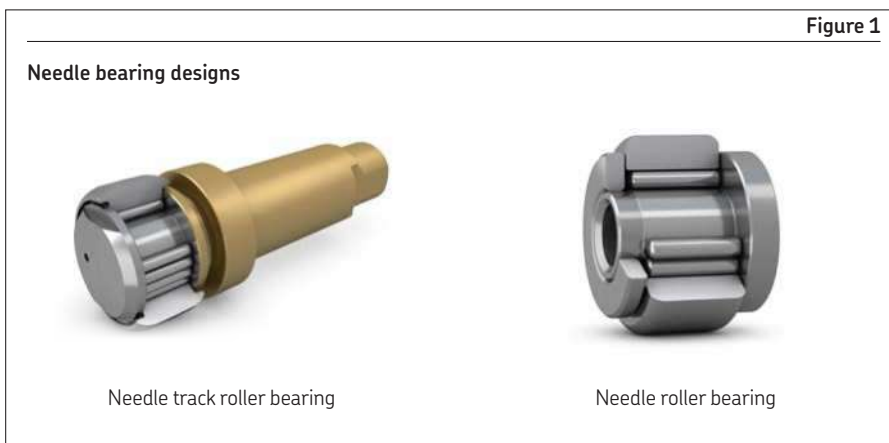

Lubrication

Needle bearings are supplied with grease, ready to be put into operation.

Depending on application conditions, they may require periodic relubrication. This is especially suitable for endurance loading conditions. For optimum bearing performance, relubrication should be performed frequently, for instance, during aircraft planned maintenance.

The lubrication helps to:

- Reduce friction
- Reduce wear rate
- Extend bearing service life
- Protect against corrosion
- Block contamination from entering the bearing

Lubricants

For typical greases used for needle bearings, see **table 1**.

Lubrication is primarily chosen according to the operating temperature.

WARNING: To prevent risk of bearing failure, use the same lubricant as supplied when relubricating.

Operating temperature

The permissible operating temperature of needle roller bearings is typically limited by the grease capability. See **table 1**.

For operation outside this temperature range, bearing life and performance may be reduced. Contact SKF.

Material

Rolling elements can be made of bearing steels for good mechanical properties or corrosion-resistant steels for increased corrosion resistance.

Axles are typically made of case-hardening steel materials with a soft core and hard surface, providing increased mechanical resistance.

Rings can be made of bearing steel for good mechanical properties, corrosion-resistant steel for increased corrosion resistance, or case-hardening steel with a soft core and hard surface, providing increased mechanical resistance.

Table 2 gives the different designations, reference standards and key characteristics of materials used for SKF needle bearings.

Surface treatments

Surface treatments are used to increase general corrosion resistance and increase fretting resistance.

Typical surface treatments can include, but are not limited to:

- Cadmium plating per AMS03-19 (Formerly DEF STAN 03-19) or AMS QQP416¹⁾
- Zinc-nickel plating per AMS 2417
- Chemical passivation per AMS 2700
- Nitriding

Contact SKF for more information and other specific surface treatments.

Table 1

Standard greases		
NATO codes	Standard	Operating temperature
G354	MIL PRF 23827 type I	-73 to +121 °C (-100 to +250 °F)
G395	MIL PRF 81322	-54 to +177 °C (-64 to +350 °F)

Table 2

Material type	Corrosion resistance	Material designation	EN	AMS	Equivalent designation
Bearing steel	Moderate	52100	EN 2031	AMS 6440 or AMS 6444	100Cr6 (100C6)
Corrosion-resistant steel	Good	440C	EN 2030	AMS 5630 or AMS 5618	X105CrMo17 (Z100CD17)
Case hardening alloy steel	Moderate	9315	EN 2099	AMS 6263	16NCD13
Case hardening corrosion-resistant steel	Good	431	EN 3490	AMS 5628	Z15CN17.03

Mounting

Needle roller bearings are typically mounted with a clearance fit between the bearing inner ring and the shaft.

Needle track roller bearings are typically mounted with a transition fit between the bearing axle and the housing (H7g6).

¹⁾ Treatment includes chromium 6 compounds and may be subject to environmental legislation



Engineered composite solutions



7 Engineered composite solutions

Design and variants	440
Structural rods	440
Adjustable rods	441
Other composite solutions	441

7 Engineered composite solutions

SKF has unique expertise in designing, manufacturing and testing composite solutions.

SKF supplies composite rods and fittings for airframe applications, customized to meet the most demanding application requirements including lightweight and high load carrying capability.

SKF composite solutions can be used to achieve a targeted stiffness and accommodate vibrations. They have low thermal expansion properties and reduce the risk of corrosion compared to metallic rod designs.

Composites can be made from:

- Glass fibre, providing electrical insulation
- Carbon fibre, providing electrical conductivity

The application of paint on composite rods is possible.

A conduction braid can also be provided.

Composite rods can be supplied with interfaces such as fork ends or rod ends and using inserted or integrated bearings. For more information about the design and capability of different interfaces, refer to *Rod ends* **page 280**, *Spherical plain bearings* **page 126**, *Rolling bearings* **page 30** and *Self-lubricating journal bearings* **page 390**.

Composite solutions can be found in many applications including:

- Centre-wing boxes
- Floor to floor connection
- Motion transmission
- Belly fairing
- Flight control applications

Design and variants

Structural rods

Structural rods are typically used in centre-wing box applications and as floor beam struts. They consist of a tube and fork end made in one monolithic composite part, see **figure 1**. They are designed to sustain high tension and compression loads.

SKF supplies dimensions from 40 to 100 mm (1.57 to 3.94 in) in tube diameter and from 600 to 2 500 mm (23.6 to 98.4 in) in length.

For information on customized designs, refer to *Other composite solutions* **page 441**.



Figure 1

Structural rods

Adjustable rods

Adjustable rods consist of a composite tube with a standard or customized metallic rod end (Refer to *Airframe rod ends*, page 280 for more information) or fork end as interfaces, see **figure 2**.

They are typically used in fairing or flight control applications.

They allow for precision length adjustment to application requirements by screwing or unscrewing of the rod end or fork end. A locking device based on standard or customized nut (with or without locking hole) and washer (tab washer, lock washer with half turn adjustment or lock washer with radial serrations) is used.

Fork ends, nuts and washers are typically made of:

- Anodized titanium
- Corrosion-resistant steel, passivated or cadmium plated
- Cadmium plated steel

The body-end connection is typically made by using a titanium insert.

SKF supplies dimensions from 14 to 40 mm (0.55 to 1.57 in) in tube diameter and from 200 to 2 000 mm (7.87 to 78.7 in) in length.

For information on customized designs, refer to *Other composite solutions*, below.

Other composite solutions

SKF Black Design composite fittings as well as other rod designs and other solutions for interfaces to applications can be supplied. Some examples are given in **figure 3**.

Contact SKF at skf.com/go/aero for more customized designs.

Figure 2

Adjustable rods



Figure 3

Examples of other composite solutions



SKF Black Design composite fitting



Customized rod design



Universal joints



Double fork end



B Customized bearings for aeroengine solutions

8 Customized bearings for aeroengine solutions 444





Customized bearings for aeroengine solutions



8 Customized bearings for aeroengine solutions

Design and variants	447
Sizes	448
Tolerances	448
Special design features and options	448
Materials	449
Materials of rings and rolling elements	449
Materials of cages	449
Storage	450
Bearing remanufacturing	450

SKF Aeroengine bearings are customized solutions for aircraft engines and transmission equipment (gearbox, drivetrain). They are high precision, compact bearings with an exceptional power to weight ratio.







Such bearings can offer long service lives and can operate at high speeds and under severe environmental conditions, such as high temperature, see **table 2**.

SKF's unique capabilities in technology development and testing of customized solutions for aeroengine bearings has helped aircraft engines to become more fuel-efficient, lightweight and reliable.

SKF supplies aeroengine ball bearings (deep groove, angular contact, three and four-point contact), cylindrical roller bearings, tapered roller bearings and spherical roller bearings, customized to meet the most demanding requirements.

Example of solutions can include but are not limited to:

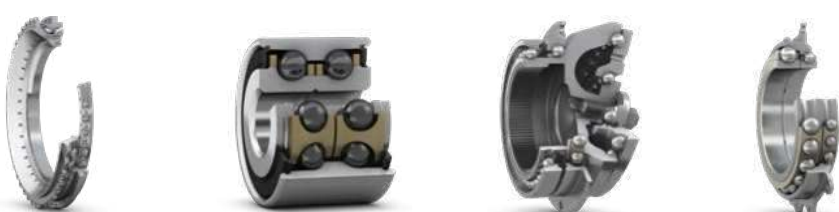
Table 1

Function	Typical SKF solutions
Engines and auxiliary power units (APU) main shaft bearings	
Accessory gearbox bearings (AGB), propeller gearbox bearings (PGB) and reduction gearbox bearings (RGB)	
Bearings for helicopter drive-trains: transmission bearings, intermediate and tail gearbox bearings, mast rotor bearings	
Helicopter main rotor bearings: swash plate bearings and blade support bearings.	
Bearings for auxiliary systems: fuel pumps, starters, flight-control gearboxes, electromechanical actuation systems and thrust reversers, telecommunication systems support.	
Spacecraft applications: engines, pumps, etc.	

Design and variants

Table 3 provides general guidelines for selecting bearing type based on application requirements. For more information, contact your regional SKF partner at www.skf.com/go/aero.

Double row deep groove ball bearings, double row angular contact ball bearings and double row tapered roller bearings are typically pre-loaded. The pre-loading is used to:

- Enhance the bearing load carrying capability
- Enhance the dynamic misalignment capability of the bearing
- Increase the bearing stiffness

Aeroengine bearings can use SKF Aerospace precision specialty balls, available in a wide range of dimensions, materials and precision tolerances to meet the most demanding application requirements.

SKF also supplies specialty balls separately for various applications including fluid and flow controls, linear guides, balls screws, or ball transfer units.

As aeroengine bearings are used in high-speed applications, they are typically oil lubricated and have cages as rolling element separators to avoid friction between rolling elements.

Table 2

Typical operating condition		
Range	Temperature (°C / °F)	Speed factor ($nd_m^{1)}$)
Low to normal	< 150 °C (< 302 °F)	< 1,5 million nd_m
Normal to high	150 °C to 220 °C (302 °F to 428 °F)	1,5 to 2,5 million nd_m
High to very high	> 220 °C (> 428 °F)	> 2,5 million nd_m

1) The speed factor nd_m is defined as the rotational speed (in rotations per minute r/min) multiplied by the bearing mean diameter (mm)

Table 3

Bearing type	Number of rows and pre-load	Load carrying capability			Misalignment		Suitable for		
		Radial load	Axial load	Moment load	Static	Dynamic	High speed	High stiffness	Low friction
Deep groove ball bearings	1 row	++	++	++	++	-	+++	++	++++
	2 rows pre-loaded	+++	+++	+++	++	+	++	+++	+++
Angular contact ball bearings	1 row	++	+++ ←	--	++	-	++++	++	+++
	2 rows pre-loaded	+++	+++	++	++	+	+++	+++	++
Three and four-point contact	1 row	++ ¹⁾	+++	--	++	-	++++	++	+++
Cylindrical roller bearings	1 row	+++	-	--	+	-	++++	+++	+++
	2 rows	+++	++	--	+	+	+++	++++	++
Tapered roller bearings	1 row	++++	+++ ←	++	-	-	+++	+++	+
	2 rows pre-loaded	++++	+++	++	+	+	++	++++	-
Spherical roller bearings	1 row	+++	++	--	++++	++	++	+++	++
	2 rows	++++	++	--	++++	++	++	++++	++

++++ excellent
 +++ very good
 ++ good
 + fair
 - poor
 ← single direction

1) Must be combined with a higher axial load

Sizes

Typical bearing sizes are from 8 mm (0.31 in.) bore to 800 mm (31.5 in.) outside diameter.

SKF Aerospace precision specialty balls have typical sizes from 0,7 to 64 mm (0.03 to 2.52 in.) in diameter.

Tolerances

Common tolerance classes for SKF Aeroengine bearings are:

ISO tolerance class ¹⁾	ABEC/RBEC equivalence	Description
Normal	ABEC 1 or RBEC 1	Minimum standard for all SKF Aeroengine bearings
Class 6	ABEC 3 or RBEC 3	Tighter tolerances than Normal
Class 5	ABEC 5 or RBEC 5	Tighter tolerances than Class 6
Class 4	ABEC 7 or RBEC 7	Tighter tolerances than Class 5
Class 2	ABEC 9	Tighter tolerances than class 4, only used for specific high demanding applications

¹⁾ Tolerance classes for radial bearings, and the corresponding values are specified in ISO 492 (Rolling bearings – radial bearings – tolerances).

In addition to bearings in accordance with standardized tolerance classes, SKF supplies bearings with customized tolerances. For more information, contact your regional SKF partner at skf.com/go/aero.

SKF Aerospace precision specialty balls used in aeroengine bearings can be provided with tolerances compliant to ABMA or ISO grade 3 to 48.

Special design features and options

• Flanges

Flanges are used for mounting and fixing the part to the application interface. This solution is especially suitable to avoid modification of the assembled fit and bearing torque when the materials used for the housing and shaft result in differing coefficients of thermal expansion.

• Customized features to accommodate vibration

Common features include flexible outer ring in steel with flanges and dampers (squirrel cages, squeeze films).

• Dismounting grooves

Aeroengine bearings are often mounted with an interference fit on the shaft. Inner rings with dismounting grooves facilitate maintenance operation, reducing time and improving safety.

• Lubrication grooves and holes

Bearings can be designed with customized lubrication grooves to direct the lubricant to the rolling contacts and improve bearing performance, or to facilitate oil drainage and reduce power loss.

• Anti-rotation features

Face slots or lugs can be used to locate the bearing rings in the housing.

For more information and more customized designs, contact SKF.

Materials

Materials of rings and rolling elements

SKF uses advanced premium quality metallic alloys, usually protected from the atmosphere and impurities by melting (or double melting) inside a vacuum container. The result is a cleaner, more uniform steel with the superior properties required for the most demanding applications.

Depending on the materials used, aerospace bearings can also be supplied with different heat treatments, such as through hardening or case hardening and with different surface treatments, such as carburizing and nitriding to meet specific application requirements.

Typical materials used for aeroengine bearings are displayed in **table 4**.

Rolling elements are made of steel (typically 52100, M50, or other corrosion-resistant steels) or ceramic. Ceramic rolling elements can be used when the application calls for:

- Light weight
- High stiffness
- Enhanced speed capability and reduced power loss
- Operation under very high temperatures and/or with exposure to contaminated environments.

Materials of cages

Typical materials for cages are:

Steel

Steel cages have high strength and can be used at elevated temperatures. Steel cages are standard for many aeroengine bearing designs. They are typically silver plated for enhanced friction performance, even with intermittently poor lubrication conditions.

Brass

Brass is unaffected by most common bearing lubricants, including synthetic oils and greases. Brass cages can be used at operating temperatures up to 250 °C (482 °F).

Machined brass cages are typically used for ball and cylindrical roller bearings (single and double row), as well as for double row angular contact ball bearings

Brass cages can also be silver plated for enhanced friction performance, even with intermittently poor lubrication conditions.

Other materials can be supplied by SKF for the cages, rings and rolling elements, customized to meet the most demanding application requirements.

Table 4

Typical ring materials

Material designation	Equivalent designation	AMS standards	Heat and surface treatment	Corrosion resistance	Use for structural parts	Performance in contaminated environment	Performance in high temperature environment
52100	100Cr6 (100C6)	AMS 6444	Through hardened	+	+	+	+
M50	80MoCrV42-16	AMS 6491	Through hardened Nitrided	+	+	++	++
M50-NiL	C-13MoCrNiV40	AMS 6278	Carburized Carburized and nitrided	+	+++	++	++
9310	–	–	Carburized	+	+++	++	+
32CDV13	32CrMoV13	AMS 6481	Nitrided	+	+++	++	++
Chromex40©	X40CrMoVN16.2	AMS 5925	Through hardened	++	+	+	++
440C	X105CrMo17 (Z100CD17)	AMS 5618	Through hardened	++	+	+	++
BG42©	–	AMS 5749	Through hardened	++	+	+	++

+++ excellent
++ good
+ moderate

Polyether ether ketone (PEEK)

Glass or carbon fibre reinforced PEEK is typically used for demanding applications where there are either high speeds or a need for chemical resistance. The maximum operating temperature is limited to 130 °C (266 °F). Excursions up to 200 °C (390 °F) can be allowed, contact SKF for more information.

For operation outside this temperature range, performance of the cage PEEK material and of the bearing can be reduced. Contact SKF for more information.

PEEK is typically used for angular contact ball bearings and for cylindrical roller bearings.

Storage

Aeroengine bearings are typically vacuum packed.

To maintain the integrity of the product during storage, SKF recommends the following practices:

- Practice a "first in, first out" inventory policy
- Store bearings flat, in a vibration-free, dry area with cool steady temperature.
- Keep bearings in their original packaging until immediately prior to mounting in application to prevent the ingress of contaminants and corrosion.
- Respect the recommended storage time indicated on the packaging. Standard storage life is five years maximum.

Beyond this limit, the ageing of the lubricant and of the packaging can lead to a reduced bearing protection and cause corrosion as well as bearing performance reduction. The bearing should therefore be inspected and reconditioned by SKF to increase the allowable storage time.

Bearing remanufacturing

SKF is EASA Part 145 certified and SKF Bearing Remanufacturing Programme is designed to return a bearing to service in the shortest possible time, while ensuring the highest quality workmanship on a very cost-effective basis. Remanufacturing includes the necessary inspections and quality controls.

A bearing repaired by SKF performs like a new bearing, with the same warranty but at a significantly lower cost.

SKF can support the maintenance of all ball or roller bearings, by performing the required inspections, regardless of the original manufacturer.

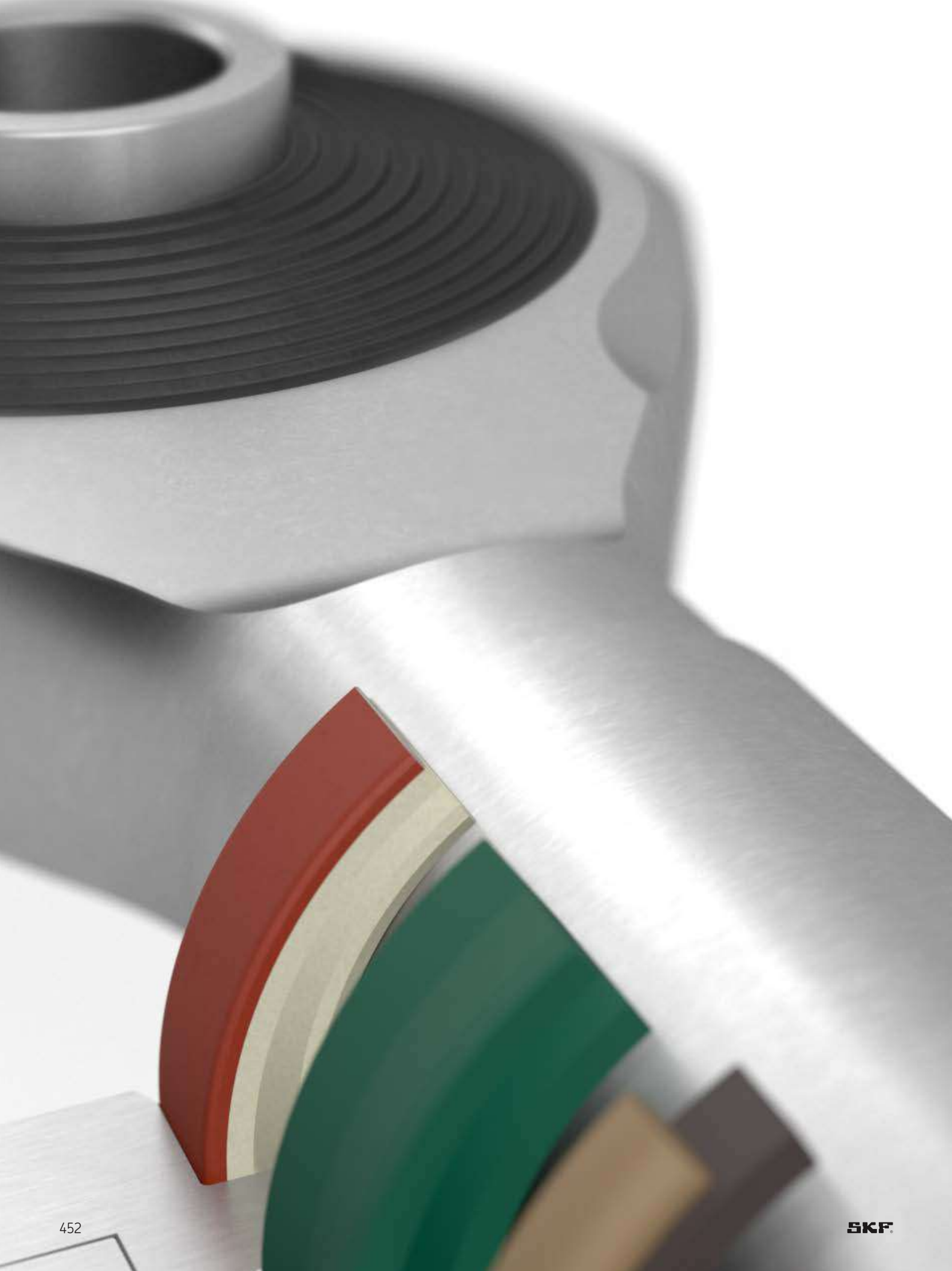

C Other aerospace solutions

9 Aerospace thin section bearings	454
10 Aerospace specialty and engineered balls	462
11 Aerospace sealing solutions	468
12 Elastomeric and damping solutions	476



Aerospace thin section bearings



9 Aerospace thin section bearings

SKF Reali-Slim thin section bearings	456
Sizes	456
Bearing types and common design features overview	457
Options	459
Cage types	459
Sealing and shielding	460
Materials	460
Rings and balls	460
Cages	461
Seals	461
Coatings	461
Bearing remanufacturing	461
Engineered designs	461
Ultra-Slim thin section bearings	461
Other engineered designs	461

SKF is a leading manufacturer of thin section bearings, including the standard SKF Reali-Slim product range, one of the most widely used thin section bearings in the world.

Such bearings have a cross-section that remains constant over the range of bore sizes. This is in sharp contrast to other bearings in which the cross-section increases as the bore diameter increases. The constant cross-section of thin section bearings is a suitable solution when designing products that vary in size depending on shaft diameter and power requirements.

SKF thin section bearing solutions save weight, create space, reduce friction, increase design flexibility and provide excellent running accuracy.

Space and weight savings of up to 85% can be achieved. Such savings are typically known to eliminate enough material and components to reduce system costs by up to 40%.

Despite their slim profile, thin section bearings have enough load capacity to meet the most demanding specifications in a wide range of aerospace applications, including target systems, navigation devices, helicopter swash plates and gearboxes, propulsion and control systems, radars, satellites, space rovers, etc. Thin section bearings are also suitable for many other applications in various industries, such as industrial machinery, oil and gas, medical and renewable energy.

SKF thin section bearings are available in the industry's largest variety of materials, cage options, cross sections, internal clearance or preload choices, lubricants, corrosion resistance options, contact angles, and precision levels.

In addition to the standard range of SKF Reali-Slim products (page 456), SKF supplies both engineered designs (including SKF Ultra-Slim thin section bearings, see page 461) and customized designs.

Specific customization of thin section bearings can include changes in materials, sizes, tolerances, specifications, internal clearances, preload, lubricants (adapted to specific low torque requirements, operating temperatures, required moisture resistance, operation under vacuum etc.), packaging, etching of high points, tagging bearings with actual dimensions as requested, cages, duplexing, data sheets, acceptance testing, use of ISO class 7 facilities for cleanroom assembly etc. Contact SKF for more information.

SKF also supplies remanufactured bearings (refer to *Bearing remanufacturing* page 461).

For more information, go to: https://www.kaydonbearings.com/downloads/210-603-Kaydon_Reali-Slim_Bearing_Catalog_Apr-2020.pdf

SKF Reali-Slim thin section bearings

Sizes

Each series of SKF Reali-Slim thin section bearings is based on a single cross section, which remains constant as the bore diameter increases. By using the same series of thin section bearings throughout a product line, common components can be standardized and the bearing envelope can be conserved.

The inch dimensions family of SKF Reali-Slim bearings includes seven open series (figure 1) and five sealed series (figure 2), ranging from 1.000 to 40.000 in. (25,4 to 1016,0 mm) bore diameters. These series range from 0.187 x 0.187 in. (4,7498 x 4,7498 mm) to 1.000 x 1.000 in. (25,4 x 25,4 mm) cross section.

For applications requiring metric boundary dimensions or for dimensional interchangeability with other products, SKF supplies the SKF Reali-Slim mm series of bearings. They can be:

- Open or sealed (figure 3)
- In cross sections of 8 x 8 mm, 13 x 13 mm or 20 x 20 mm
- With bore diameters ranging from 20 mm to 360 mm

Figure 1

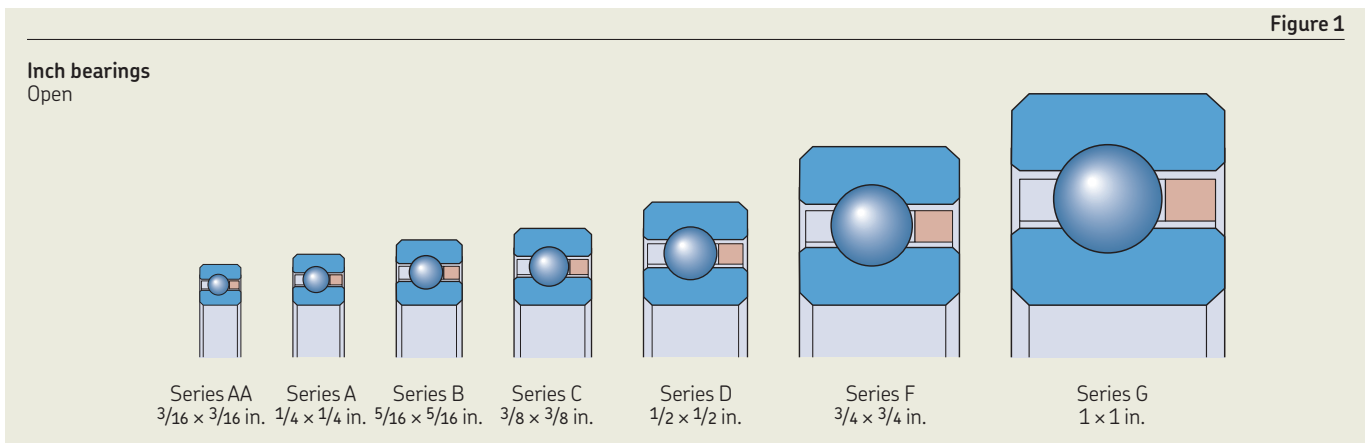

Bearing types and common design features overview

To support various load scenarios (radial, axial and moment load), SKF Reali-Slim bearings are available in three basic types: radial contact (Type C), angular contact (Type A), and four-point contact (Type X). Open bearings are available from stock in three configurations (Types A, C and X). Stock sealed bearings are available in Types C and X only. Refer to *Bearing types* page 458.

SKF provides options such as special lubricants, and materials including ceramic balls, as well as other features to meet the most demanding specifications. For enhanced corrosion resistance the SKF stainless steel SKF Reali-Slim or Endura-Slim series of bearings can be used. Endurakote plating can also be used to provide corrosion protection equal to or better than a full 440C stainless steel bearing. Refer to *Materials and Coating* pages 460 and 461.

SKF supplies both open or sealed bearings. Sealing is used for applications where bearings can be exposed to damaging particulates. Refer to *Sealing and shielding* page 460.

SKF Reali-Slim bearings are available with various cage options to space the rolling elements uniformly and prevent contact between them. Cage types include continuous ring “snap-over pocket”, continuous ring circular pocket, formed wire, toroid, polytetrafluoroethylene (PTFE) spacers, and spacer ball separators. Refer to *Cage types* page 459.

Bearings can be provided in a wide range of:

- Precisions, typically from class 1 per ABEC 1F to class 6 per ABEC 7F.
- Internal clearances, typically from 0.0000 to 0.0005 in. (0,000 to 0,127 mm), and up to 0.0050 to 0.0060 in. (0,127 to 0,1524 mm), or preload, typically from 0.0000 to 0.0005 in. (0,000 to 0,127 mm), and up to 0.0020 to 0.0030 in. (0,0508 to 0,0762 mm).

Table 1, page 458 gives the key characteristics of the different types of SKF Reali-Slim bearings.

Figure 2

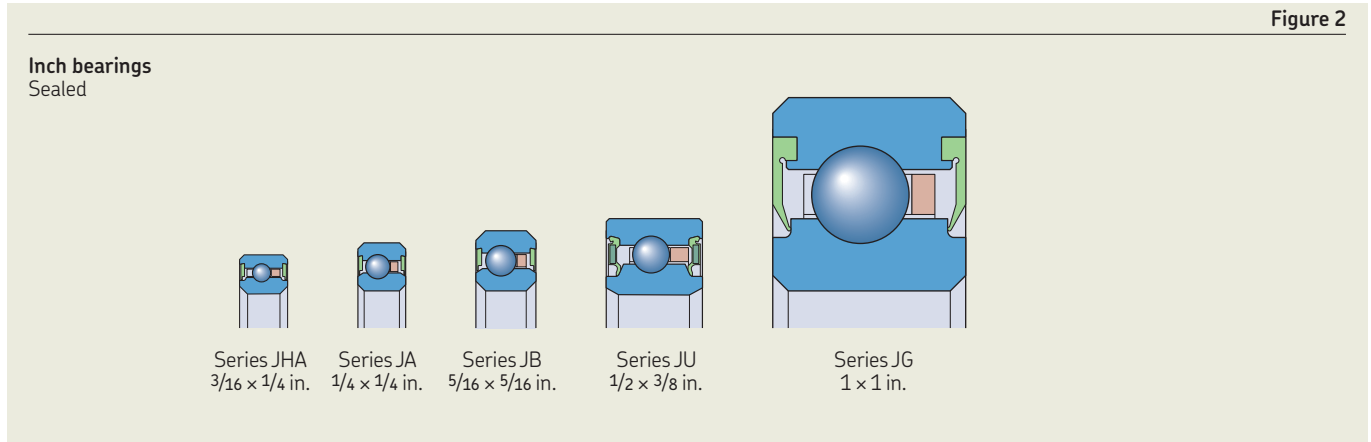
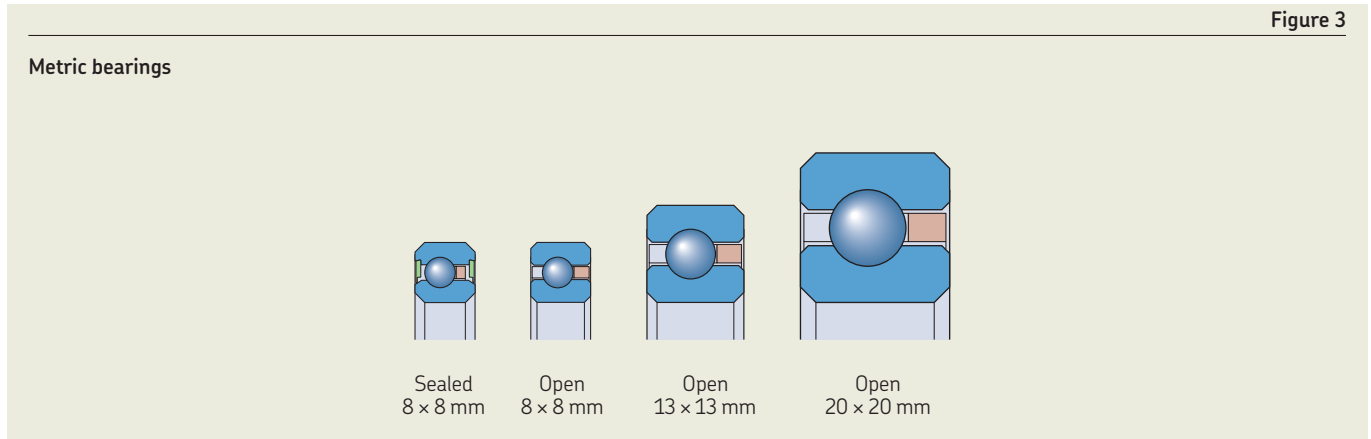
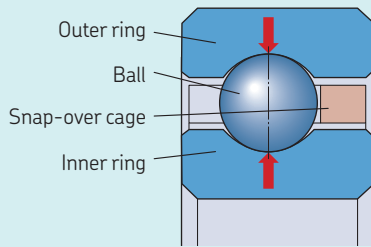

Figure 3



Bearing types

Radial contact bearing (Type C)



Description

A single row radial ball bearing of conventional design. It is a Conrad-type assembly, which means that it is assembled by eccentric displacement of the inner ring within the outer ring which permits insertion of about half of a full complement of balls.

Although the Type C bearing is designed primarily for radial load application, it can be configured to accept some axial (thrust) load in either direction. But, if thrust is a concern, a set of angular contact bearings should be considered for the specific application.

Angular contact bearing (Type A)

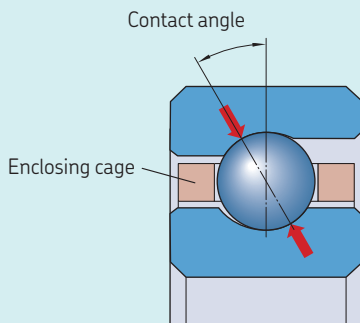

A deep groove bearing with reduced shoulder on one side of inner or outer ring raceways. The Type A bearing is also a conventional design. It features a circular pocket cage and a 30° contact angle along with approximately 67% of a full complement of balls. The chief benefit of the Type A bearing is that it provides greater thrust capacity than a Type C or Type X bearing. Because of its counterbored outer ring, a Type A bearing has unidirectional thrust capacity. Thus, this bearing should be mounted in opposition to another bearing to establish and maintain the contact angle, and to support reversing thrust loads.

Four-point contact bearing (Type X)

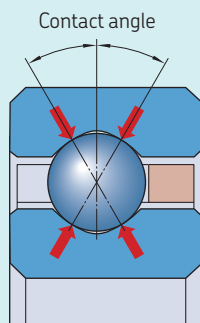

Standard bearing products are most often designed to handle either radial or axial loading conditions. The unique feature of the Reali-Slim Type X four-point contact bearing is that the gothic arch geometry of the inner and outer rings enables a single bearing to carry three types of loading (radial, axial and moment) simultaneously if needed. This makes it the bearing of choice for many applications since a single four-point contact bearing can often replace two bearings, providing a simplified design. Type X bearings may also be furnished with an internal diametral preload for those applications requiring greater stiffness or zero free play. This is accomplished by using balls that are larger than the space provided between the raceways. The balls and raceways, therefore, have some elastic deformation in the absence of an external load.

NOTE: SKF does not recommend the use of two Type X bearings on a common shaft, as it could result in an unacceptable frictional moment.

Options

Cage types

The principal function of a bearing cage is to space the rolling elements uniformly to prevent contact between them. This is to avoid abrasion of the rolling elements and reduce bearing wear that could affect life and torque characteristics.

Typical cage designs include:

- The commonly used standard continuous ring “snap-over pocket” cage (**figure 4**)
- Continuous ring circular cages, when a larger number of rolling elements is required (**figure 5** and **figure 6**)
- Formed wire cage, when maximum capacity is required. This enables the greatest possible number of balls on Type A bearings (**figure 7**).

In some critical positioning applications, uniformity of torque is more important than the actual mean torque level. Specially designed toroids (**figure 8**), PTFE spacer slugs (**figure 9**), spacer balls (**figure 10**) or helical compression springs (**figure 11**) have proven in a number of such instances to be satisfactory for ball separation – by their nature they give a large amount of individual and cumulative circumferential freedom to the balls. To prevent this freedom from being detrimental, the rotational speeds must be kept low and loads comparatively light.

SKF can support the selection of the most appropriate cage or spacer solution. Contact your regional SKF Aerospace partner at: skf.com/go/aero

Figure 4

Continuous ring “Snap-over pocket” cage

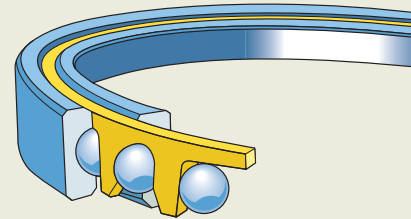

Figure 5

Continuous ring pocket cage

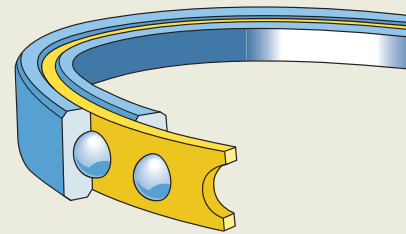

Figure 6

Riveted ring circular pocket cage

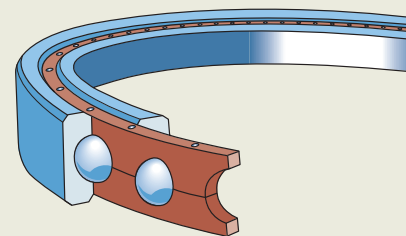

Figure 7

Formed wire cage

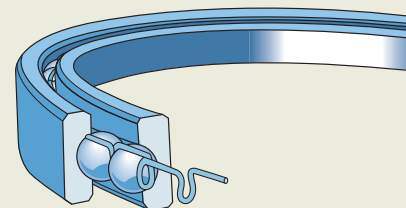

Figure 8

Toroid spacer

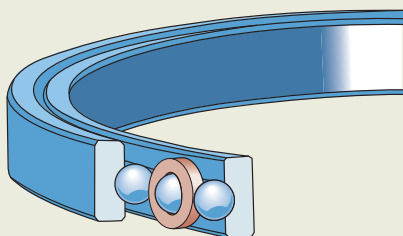

Figure 9

PTFE spacer slugs

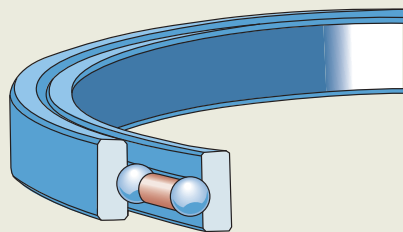

Figure 10

Spacer balls

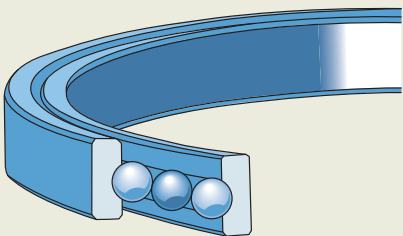
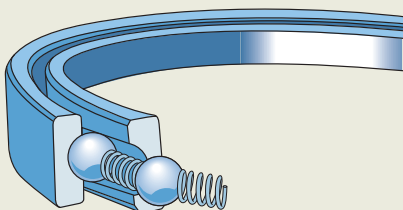

Figure 11

Helical spring



Sealing and shielding

For optimum performance of SKF Reali-Slim thin section bearings, it is important to keep them clean and well lubricated. Properly designed and mounted seals and shields help accomplish this.

A sealing solution creates a contacting closure between the stationary and rotating parts. Seals are retained in the outer ring and make positive contact with the inner ring.

A shielding solution also creates a closure but without positive contact.

Seals are more effective to retain the lubricant within and exclude contamination from the bearing. But sealing increases bearing torque, generates more heat, and as a result, sealed bearings have a lower speed limit than an open or shielded bearing. Integral seals and shields offer a very compact overall design with the additional advantage of protecting the bearing before, during and after installation.

Where application requires a low weight compact solution, and when a seal or shield is required on one side only, single-sealed or single-shielded bearings are available as custom options.

NOTE: Sealed Reali-Slim bearings are pre-lubricated with a general-purpose grease. Operating conditions (i.e. time, temperature, speed, environment) may result in premature lubrication degradation. A variety of lubricants are available as options to meet the most demanding application requirements.

Materials

Rings and balls

Rings and balls are made of 52100 type steel per ASTM A-295 or of 440C stainless steel per AMS 5630 when better corrosion resistance is required.

Stainless steel is typically required when the bearing needs to:

- Operate in close proximity to corrosive chemicals
- Operate with lubricants which do not protect against corrosion
- Be ready-to-use, ultra-clean bearings with no preservative on them

440C stainless steel meets a minimum of 58 HRC hardness level and can support the same loading as 52100 steel.

Rolling elements can also be provided in ceramic material. Such bearings are generally referred to as hybrid bearings. The physical properties of the ceramic rolling elements (precision, hardness, light weight) provide additional benefits such as improved repeatability, low torque, high stiffness, and resistance to wear under marginal or no-lube conditions.

In applications where both corrosion resistance and chemical resistance are required, P series bearings may be required. These bearings have rings made of 17-4PH stainless steel and have ceramic balls.

Standard bearings are processed for operating temperatures up to 121 °C (250 °F). At temperatures above this limit, reductions in material hardness can affect bearing capacity, which will reduce the bearing's dynamic life. When full capacity is required at higher temperatures, the use of M series bearings may be required.

Manufactured from M50 tool steel for balls and rings and assembled with stainless steel cages, these bearings can provide full bearing capacity at temperatures greater than 121 °C (250 °F). However, careful consideration to the bearing lubricant must also be taken.

Cages

Cages are made of brass, stainless steel, non-metallic materials such as phenolic laminate, PTFE, and polyether ether ketone (PEEK) or other materials depending on operating conditions.

Stainless steel cages are used in stainless steel bearings or high temperature applications for corrosion resistance. Non-metallic cages are used where light weight and/or lubricant absorption are required.

Seals

Seals are typically made of nitrile rubber. For operation at high temperatures or in contaminated environments, silicone or Viton materials can be used.

Coatings

Endurakote plating protects bearings from corrosion and provides substantial life improvements in contaminated environments. Endurakote plating is applied over conventional bearing materials such as 52100 steel and offers the same corrosion resistance as bearings made of 440C stainless steel. The coating is applied to the entire bearing ring surface, including the raceways, leaving no area unprotected from corrosion. Endurakote plating is hard chromium, electrodeposited by a proprietary process. The hard, dense exterior surface formed by the coating is excellent in the retention of the lubricant film and is extremely wear resistant. Endurakote plating achieves a true molecular bond, and will not flake or peel even under the high contact stresses experienced in the bearing contacts.



Bearing remanufacturing

The SKF Bearing Remanufacturing Programme is designed to return a bearing to service in the shortest possible time, while ensuring the highest quality workmanship on a very cost-effective basis. Remanufacturing includes the necessary inspections and quality controls.

A bearing repaired by SKF performs like a new bearing, with the same warranty but at a significantly lower cost.

Bearings with bores as small as 250 mm (10 in.) and bearings with outer diameters as large as 6 100 mm (240 in.) can be remanufactured. SKF remanufacturing solutions extend to all ball and roller bearings, regardless of the original manufacturer.

Engineered designs

Ultra-Slim thin section bearings

Ultra-Slim bearings have an extremely thin cross section that provides great size and weight reductions for light to medium duty applications with slow or intermittent rotation.

They are used for applications in aerospace, robotics or anywhere precise positioning and lightweight designs are critical. At just 2,5 mm (0.1 in.) wide, Ultra-Slim bearings are available in bore sizes ranging from 35 to 170 mm (1.38 to 6.7 in.). Their compact profile allows the use of Ultra-Slim bearings in many highly confined spaces. Ultra-Slim bearings are made of stainless steel for corrosion resistance. They are available as angular contact (Type A), radial contact (Type C), and four-point contact (Type X) bearing types.

Hybrid bearings with ceramic balls are available on request. These are often used when lubrication is marginal or when lower wear generation and/or lower torque levels are required.

Other engineered designs

SKF supplies other engineered thin section bearing designs, including:

- Metric ball bearings four-point contact BB series, typically used as an alternative to cross-roller bearings
- SKF Reali-Slim TT series, four-point contact, small scale, thin section turntable bearings
- Tapered roller bearings KT series, single row radial type

For other engineered and customized designs, contact SKF.



10

Aerospace specialty and engineered balls



10 Aerospace specialty and engineered balls

- Products** **464**
- Flatted balls..... 464
- Hollow balls..... 464
- Ball plugs..... 465
- Tooling and checking balls 465
- Master ball sets..... 465

- Materials** **466**

- Ball grades**..... **467**

In addition to supplying precision aerospace specialty balls, typically used for rolling bearings (refer to *Airframe rolling bearings* page 30 and *Aeroengine rolling bearings* page 444), SKF supplies other types of balls in a wide range of materials, sizes and grades, engineered to meet many different aerospace and industrial applications.

Flatted balls, hollow balls and ball plugs are used in fluid and flow control applications. For measurement and positioning, SKF supplies tooling and checking balls, and master ball sets.

SKF also supplies a wide range of customized ball designs to meet the most demanding application requirements.

Products

Flatted balls

Flatted balls are typically used in fluid and flow control devices such as valve stems. They can also be used as shoes in rotating equipments, such as swash plate shoes. They can be supplied in a wide range of materials and sizes: 1,5 mm to 63,5 mm ($1/16$ to 2.5 in.) diameter. Some examples are given in **figure 1**.

Hollow balls

Hollow balls are typically used in ball transfer units and fluid control devices such as fluid and tank valves. They can be supplied in a wide range of materials and sizes: 9,525 mm to 63,5 mm ($3/8$ to 2.5 in.) diameter. See **figure 2**.

Figure 1

Flatted balls



Figure 2

Hollow balls



Ball plugs

Ball plugs are typically used during the investment casting process of airfoils and blades, where tubular channels or vent holes in the casting are plugged by ball elements.

Ball plugs can be customized to application requirements. SKF supplies any increment of sizes from 1,5 to 25,4 mm (*1/16 to 1 in.*) diameter.

Typical materials used for ball plugs include nickel alloyed steels such as Hastelloy. For more information, refer to *Materials* page 472.

See example in **figure 3**.

Tooling and checking balls

SKF tooling and checking balls are extensively used as metrology tools. They can be supplied in many metric or inch sizes. They are typically made of high precision finely finished 440C stainless steel material with hardness 55 to 58 HRC.

Designs can include:

- A reference shoulder for positive positioning and re-positioning.
- A shank that can be press-fitted into a hole.

Some examples are given in **figure 4**.

Master ball sets

Master ball sets are extensively used as metrology tools for close-tolerance measurements. SKF ball sets have the necessary certifications, including that of the National Institute of Standards and Technology.

Typical applications include checking of flatness and parallelism, as well as depth and diameter measurements.

Materials used are highly corrosion resistant, humidity resistant and abrasion resistant, such as tungsten carbide tool steel.

The following specifications are supplied :

Specification	Inch set	Metric set
Size range	1/16 to 1 in. (<i>1,5875 to 25,4 mm</i>) diameter in 1/32 in. (<i>0,79375 mm</i>) increments, with 31 balls per set	1 to 25 mm in 1 mm increments, with 25 balls per set
Diameter tolerance	±0.000010 in. (<i>0,254 μm</i>)	±0,3 μm
Sphericity	0.000010 in. (<i>0,254 μm</i>)	0,2 μm
Micro-finish	1 μin. (<i>0,0254 μm</i>)	0,02 μm
Hardness HRA	88 to 92	88 to 92

Some examples are given in **figure 5**.

Figure 3

Ball plugs



Figure 4

Tooling and checking balls



Figure 5

Master ball set



Materials

SKF supplies balls in a wide range of materials, designed to meet a variety of needs, including:

- **52100 steel**

The standard material for most off-the-shelf balls, with excellent strength characteristics and the capability to withstand moderate impact loading conditions. With suitable through-hardened heat treatment, 52100 steel can be used at operating temperatures up to 200 °C (400 °F).

- **Tool steels such as M50 steel**

Suitable for temperatures between 200 and 427 °C (400 and 800 °F), M50 steel maintains its hardness, capacity and thermal stability better than standard bearing steels in high-temperature applications. The vacuum arc re-melting process used to produce M50 steel results in extremely clean material that is highly resistant to wear and oxidation, offers consistent metallurgical properties, and maintains a typical hardness range of 60 to 65 HRC.

This material can be nitrided (M50-NiL steel) for greater fracture toughness that makes it ideal for high-temperature applications that also involve high shock loading conditions.

- **440C stainless steel**

This high carbon chromium steel is designed to provide maximum hardness in stainless ball applications. When heat treated, 440C stainless can attain 63 HRC hardness.

Balls made of 440C stainless perform exceptionally well in corrosive environments. When treated with a low-temperature process using liquid nitrogen, they can maintain their stability at temperatures down to nearly -185 °C (-300 °F).

- **Silicon nitride**

The characteristics of silicon nitride make it ideal for use in applications where high speed, high temperature, low operating noise, electrical insulation, high stiffness and high hardness are required. As a result, ceramics balls offer significant advantages over traditional materials when used in rolling bearings, ball valves, gage tips and ballizing applications.

SKF has pioneered the use of silicon nitride balls by developing a unique production process and the quality control procedures required to reliably manufacture high precision, ceramic rolling elements.

The result of this process is exceptional quality and reliable performance.

- **Other materials for specific applications**

Other corrosion-resistant steels and tool steels (including tungsten carbide tool steel), nickel based alloys (including Inconel or Hastelloy) or cobalt alloyed steel for high temperature applications, non-metallic (including nylon, typically used for lightweight solutions) and glass materials, titanium alloys, etc.

Ball grades

SKF Aerospace specialty balls can be supplied with tolerances compliant to ABMA grade 3 to 1000. See **table 1** for more information.

Table 1

SKF Aerospace specialty ball grades				
ABMA grade	Ball diameter tolerance	Spherical form uniformity tolerance	Basic diameter tolerance	Surface roughness
$\mu\text{in./}\mu\text{m}$				
3	3/0,08	5/0,13	± 30 $\pm 0,75$	0.5/0,012
5	5/0,13	10/0,25	+50/-40 +1,25/-1,00	0.8/0,020
10	10/0,25	20/0,50	+50/-40 +1,25/-1,00	1.0/0,025
16	16/0,40	32/0,80	+50/-40 +1,25/-1,00	1.0/0,025
24	24/0,60	48/1,20	± 100 $\pm 2,50$	2.0/0,050
48	48/1,20	96/2,40	± 200 $\pm 5,00$	3.0/0,080
100	100/2,50	200/5,00	± 500 $\pm 12,50$	5.0/0,125
200	200/5,00	400/10,00	± 1000 $\pm 25,00$	8.0/0,200
500	500/13,00	1000/25,00	± 2000 $\pm 50,00$	- 1)
1000	1000/25,00	2000/50,00	± 5000 $\pm 125,00$	- 1)

1) Not applicable



Aerospace sealing solutions



11 Aerospace sealing solutions

Product range	470
Materials	470
Sealing rings	471
Aerospace carbon seals for turbine engines	472
Applications	472
Radial shaft seals	472
Diaphragm seals and boots	473
Cassette seals	473
Wear sleeves	473
SKF Speedi-Sleeve	473
SKF Speedi-Sleeve Gold	473
Custom designed wear sleeves	473
Hydraulic seals	474
Piston seals	474
Rod and buffer seals	474
Wiper seals	474
Guide rings	474
Fluid handling seals	475
SKF Spectraseal	475
Rotary manifold seals	475
Locking T-seals	475

SKF supplies a wide range of sealing solutions, from seal replacement to the design of customized seals for extremely demanding applications. This is enabled by SKF's unmatched understanding of the interaction between seals, bearings, lubrication and operating conditions (temperatures, speeds, pressures, etc.).

With unique capabilities in seal design, materials, testing and manufacturing, SKF sealing solutions meet the most demanding application requirements. They can be found in power transmission systems, actuators, pumps and fluid handling systems.

SKF supports the entire product life cycle with:

- SKF simulation tool for seals, used to explore the non-linear behaviour of various sealing materials and designs. This helps to predict sealing performance under various operating conditions.
- Tests that can be conducted on-site at your location, or at one of our global testing facilities. Seals can be tested in static or dynamic loading conditions using rotating and reciprocating test rigs capable of simulating operating conditions including extreme pressures and temperatures. SKF testing capability also includes tests of durability, performance, contaminant exclusion, salt fog corrosion, cold fracture, pump rate, frictional moment, dry wear, and chemical compatibility.

For example, SKF has made significant investments in high speed test rigs for carbon seals to allow demonstration testing of new designs and validation testing of design changes. Testing is performed to match flight profiles for engine applications under simulated flight conditions.

Results from thousands of seal tests conducted by SKF annually, generate valuable know-how for failure analyses and performance optimization.

- High manufacturing flexibility. SKF manufacturing capability includes both moulded (in compression, injection or transfer) and machined seals. SKF manufactures seals on demand and delivers them worldwide and in quantities ranging from a few parts (prototypes for example) to serial production.

Product range

Aerospace seals are available in a wide range of designs and materials, for applications from the smallest gearbox to the largest swash plate.

SKF's assortment comprises many products that meet international and customer standards including ISO, ASTM, or DIN standards.

When needed, a combination of different seals and arrangements can be used to achieve best sealing performance in complex operating conditions.

Materials

Aerospace seals are exposed to a wide range of challenging operating conditions such as high temperature, speed, pressure and contact with chemicals. To handle these and other harsh conditions, it is essential to select the most suitable sealing materials.

To meet the most demanding application requirements, SKF sealing solutions use a wide range of rubbers, thermoplastic elastomers and other materials such as high-performance plastics:

- **Thermoset elastomers**

Extremely flexible materials that can be stretched and deflected with relatively little force. Many of them deliver excellent resistance to oils, greases, or other media.

- **Thermoplastic elastomers**

Thermoplastic elastomers offer advantages typical of both rubber and plastic materials. SKF's high performance polyurethanes (TPU) combine excellent abrasion and wear resistance, low compression set and tear strength, and outstanding pressure resistance.

- **PTFE**

Engineered to handle extreme conditions, polytetrafluoroethylene (PTFE) and its compounds can withstand aggressive chemicals plus high temperatures and pressures. Thanks to their extremely low coefficient of friction, they can also tolerate dry running conditions.

- **Carbon**

Carbon is typically used for applications with very high-speed and high-temperature rotary sealings, as in aircraft engine and auxiliary power unit (APU) main shafts. In such extreme operating conditions, elastomer, thermoplastic or PTFE materials may not be adequate.

- **Plastics**

From engineering plastics to high performance plastics such as polyether ether ketone (PEEK), SKF's range of specialty plastic materials can meet higher temperature, chemical and mechanical property requirements.

- **Other materials**

Including rubbers and metals. SKF also constantly develops solutions that are uniquely engineered for high performance applications, such as ECOPUR thermoplastic polyurethane, a proprietary SKF material.

Sealing rings

SKF is a major designer and manufacturer of sealing rings, used to meet the most demanding application requirements.

SKF sealing rings are specified for a broad range of static and dynamic aerospace applications including:

- Turbine engine bearing damper
- Piston engines
- Secondary seals in carbon seal assemblies
- Actuators
- Auxiliary power units (APU)
- Environmental control units
- High temperature valve applications

Patented joint configurations are available for applications requiring the strictest leakage control and for blind assembly applications. Various coatings are also used and are specified based on the needs of the application.

For sealing rings, SKF provides a proprietary AMS 7310 iron. This is a preferred ring material for many aircraft engine applications with a proven history of superior performance characteristics. Metallic ferrous rings, high temperature alloys such as Inconel, and thermo-plastic and thermoset non-metallic materials can also be supplied. For example, SKF's proprietary PTFE blends can be used for optimum wear and sealing efficiency to meet specific application requirements.

SKF designs and supplies the optimum sealing ring solution for your application to ensure long life, performance and reliability.

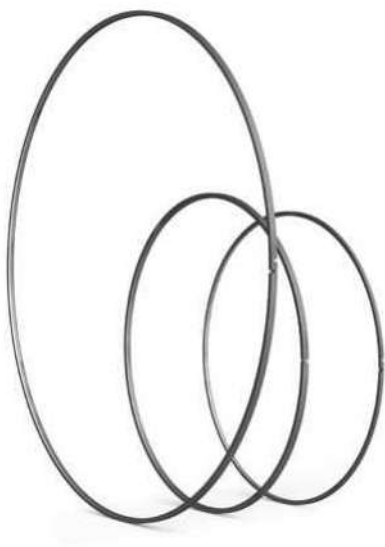

Sealing rings

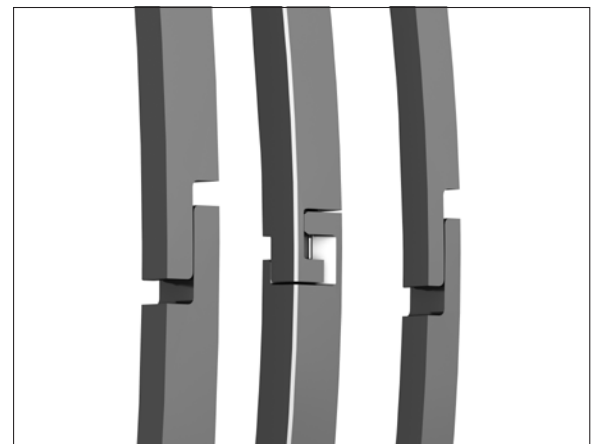

Sealing ring solutions

Aerospace carbon seals for turbine engines

Carbon seals reduce costs by extending life and delivering outstanding performance in harsh operating conditions, setting quality standards for many commercial and military engines.

Applications

- Main shaft bearing seals in aircraft engines
 - Bearing compartment face seals
- Bearing compartment circumferential seals
- Bearing compartment bushing seals
- Main engine bearing compartment seals
 - Turbine engine shaft seals to seal the main shaft bearing compartment and oil sump
- Air seals
- APU seals
- Auxiliary gear box seals
- Engine seals

SKF carbon seals can be designed with features providing hydrodynamic capability. Such features have shown clear performance advantages in reducing heat generation and extending seal life, reducing load on engine oil management systems and maximizing time on wing.

SKF carbon seals can be supplied with shaft seal runners. Runners are used to interface with the seal. They have a fine surface finish and surface treatment to ensure optimum performance. SKF also supplies other support structures and spacers to the sealing assemblies to assure the proper interface of mating components.

Radial shaft seals

SKF supplies an array of proven shaft sealing solutions that protect bearings, keep lubricants in and improve system reliability.

At work in power transmissions across aerospace and every major industry, SKF radial shaft seals support greater uptime in everything from the smallest high-speed machine tools to the largest wind turbines.

SKF rubber and metal outside diameter shaft seals resist aggressive aerospace oils and can be designed with hydrodynamic features to optimize the functionality of the seal. Such designs are moulded in geometries that induce a hydrodynamic pumping action that allows the temperature under the lip to remain lower and reduces the carbonization of oil at the main sealing surface.

11



Carbon seals



Radial shaft seals

Diaphragm seals and boots

Diaphragm seals are used for sealing across a shaft or inner member to the housing. They handle the torsional motion or oscillation of the shaft.

Boots are used for sealing in applications with reciprocation or torsional motion.

Diaphragm seals and boots are thin walled products with unique convoluted shapes. They are used for contamination exclusion in dynamic applications with torsional and/or rotational motion.

SKF offers a wide range of materials to meet the most demanding applications requirements.

Cassette seals

Cassette seals are multi-component seals that provide an optimized sealing counterface by incorporating a wear sleeve (refer to *Wear sleeves* for more information). It uses high-performance elastomeric materials and allows for the inclusion of multi-lip designs to improve contamination exclusion and sealing performance.

Wear sleeves

Over time, contaminants, high pressure and speed, or inadequate lubrication can cause particles to be trapped underneath a shaft sealing lip. Wear grooves begin to form on the shaft as it rotates, eventually leading to sealing failure and severe shaft damage.

Repairs usually involve dismounting, replacing or re-machining the shaft, and installing a new seal. SKF Speedi-Sleeve and custom designed wear sleeves offer a much faster, more cost-effective alternative.

SKF Speedi-Sleeve

SKF Speedi-Sleeve is a thin-walled wear sleeve that is simply pressed into position over the shaft to provide an excellent sealing surface for radial shaft seals. In fact, its surface properties result in a better counterface than what can normally be achieved on a shaft. Whether it is used to reduce initial shaft machining expenses or to limit downtime costs while repairing a worn shaft, SKF Speedi-Sleeve offers enhanced sealing system performance and benefits for both OEM and aftermarket customers – without the need to change the original seal size.

SKF Speedi-Sleeves are made of a proprietary stainless steel material, providing increased strength and excellent ductility properties. Imperceptible lubricant pockets enable the lubricant to reside on the sleeve and prevent dry running of the sealing lip that otherwise can create excessive wear.

SKF Speedi-Sleeve Gold

SKF Speedi-Sleeve Gold is an enhanced version of the standard SKF Speedi-Sleeve, offering improved resistance to abrasive wear. Designed for applications where extended sealing system life is needed, SKF Speedi-Sleeve Gold bridges the performance gap between the standard sleeve and expensive custom shaft treatments. A thin, metallic coating applied to the base stainless steel imparts a gold colour and significantly increases durability. SKF Speedi-Sleeve Gold is particularly effective in environments where there are abrasive contaminants, especially when combined with a seal manufactured from the SKF fluoro rubber material, SKF Duralife.

Custom designed wear sleeves

Designed in various thicknesses and diameters to suit the application, these replaceable wear sleeves are manufactured with the correct surface finish to ensure optimum performance from the sealing system.



Diaphragm seal and boot



Cassette seal



Wear sleeves

Hydraulic seals

For fluid power applications like hydraulic cylinders, seals have to withstand extreme operating conditions and high-power density demands. SKF can meet these requirements with highly engineered designs and proprietary material formulations that provide outstanding mechanical properties and excellent chemical compatibility with various hydraulic fluids.

Piston seals

Piston seals maintain sealing contact between the piston and the cylinder bore. Optimized for single and double-acting cylinders, piston seals prevent leakage past the piston while allowing an oil film to minimize friction and wear. The SKF piston seal profiles can feature:

- Polyamide/nitrile, polyurethane materials or SKF's proprietary X-ECOPUR PS material, developed specifically for piston seals
- Step-shaped split for easy installation and effective sealing for high pressure applications
- Optimized dynamic surface profiles and side vent notches

Rod and buffer seals

Rod and buffer seals maintain sealing contact in sliding motion between the cylinder head and the piston rod. SKF has a wide range of rod and buffer seals to prevent failures and boost system reliability.

Designed for heavy-duty applications, rod seals are typically single lip and made of SKF's proprietary ECOPUR thermoplastic polyurethane.

Designed to protect the rod seal from system pressure spikes, SKF buffer seals support rod seal functionality and longer hydraulic cylinder service life. They are typically U-cup designs suitable for heavy-duty applications.

Wiper seals

SKF wiper seals prevent contaminants from being transported into the system with the reciprocating piston rod.

SKF supplies single-acting press-in profiles, widely used in applications with heavy contamination. For snap-in applications, SKF supplies solutions featuring the functional benefits of a press-in seal, but with snap-in convenience and better rod tracking.

Guide rings

Non-metallic SKF guide rings accommodate radial loads acting on the cylinder assembly, prevent wear and guide the rod in the cylinder head as well as the piston in the cylinder bore to avoid damage. This can lead to smoother operation and longer service life.

SKF polymeric material guides are precision machined and available in reinforced polyamide, phenolic resin and fabric or PTFE, and deliver substantial improvements in seal life and sealing performance. For heavy duty applications, SKF guide rings include piston guide rings, rod guide rings or solutions that can be used in either rod or piston applications.

11



Piston seals



Rod and buffer seals



Wiper seals



Guide rings

Fluid handling seals

For fluid handling applications where seals come into direct contact with aggressive fluids or slurries, SKF supplies sealing solutions that can withstand these harsh conditions.

SKF Spectraseal

The SKF Spectraseal product line is used when conventional elastomer or thermoplastic seals cannot withstand temperature extremes from cryogenic temperatures of -193 to $+290$ °C (-315 to $+550$ °F), aggressive chemicals and solvents, abrasive or non-lubricating media, high surface speeds and/or high pressures. SKF Spectraseal are seals machined from engineered plastic materials such as PTFE-based compounds, ultra-high molecular weight polyethylene (UHMWPE), PEEK and other high performance plastics. They are also available in materials with a very low coefficient of friction, enabling sealing at high surface speeds in dry or non-lubricated conditions while reducing linear or rotating friction.

Rotary manifold seals

SKF rotary manifold sealing solutions maintain proper fluid flow between machine components for virtually any application, including those optimized for low friction to enable greater energy efficiency and service life.

Locking T-seals

The Locking T-seal is an SKF patented design where a ridge on the hard plastic anti-extrusion ring is able to snap into a groove moulded or machined into the elastomer lip, locking the T-seals anti-extrusion ring in the right position.

Locking T-seals from SKF enable easier assembly and less risk of damage, even in remote locations or with automated equipment. The seals feature ridges that snap into place when installed and mechanically lock the anti-extrusion rings in the proper orientation. The seals can also be used in dynamic reciprocating applications, as well as high-pressure static connections.



SKF Spectraseal



Rotary manifold seals



Locking T-seal



12

Aerospace elastomeric and damping solutions

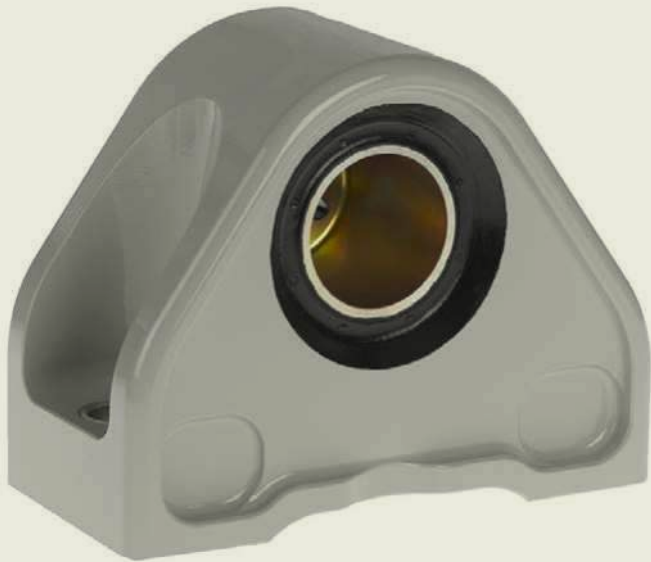

12 Aerospace elastomeric and damping solutions

Product range 478
Elastomeric bearings 478
Isolators and mounts 479
Dampers 479

Today, reduced direct operating costs (DOCs) and improved efficiencies and sustainability are driving new aircraft design. To achieve these goals, SKF supplies aerospace elastomeric solutions that:

- Carry heavy loads while absorbing, dampening and controlling large deflections occurring simultaneously in several directions
- Make aircraft lighter by reducing multi-component assemblies into single-units for compactness and minimal maintenance requirements
- Provide longer life and good performance in operation under severe environmental conditions including humidity and contamination (such as dust)

SKF has extensive experience in developing, engineering, testing and manufacturing elastomeric solutions. SKF's unmatched expertise is used to optimize elastomeric solutions by making them quieter, smoother, safer and more reliable. Through custom formulation, compounding, moulding and bonding of precision elastomeric products, SKF solves the most demanding application specific problems in aerospace.

For example, replacing traditional helicopter main rotor hubs with elastomeric bearings can result in:

- 75% reduction in the number of parts
- 20% reduction in weight
- 50% life increase
- 75% reduction in maintenance costs

Product range

Aerospace elastomeric solutions are produced by layering elastomers between shims of substrates.

SKF supplies a wide range of materials including high quality elastomeric formulas and specific rubber compounds to meet your needs.

SKF supplies a wide range of elastomeric solutions, as presented below. They can be customized to meet the most demanding application requirements.

Elastomeric bearings

Elastomeric bearings are of a laminated design built up from thin individual layers. They are used as flexible joints to accommodate multi-modulus deflections with minimized power loss and optimized stress-strain distribution. Some examples are given in **figure 1**.

Figure 1

Elastomeric bearings
Product examples



Isolators and mounts

Isolators and mounts are solutions with a targeted stiffness to accommodate vibration within a system or as a joint between components. They are made of materials with extensive resistance to environmental conditions including contamination and temperature. Some examples are given in **figure 2**.

Dampers

Dampers use modulus adjustable materials to:

- Reduce the hysteresis effect
- Absorb shocks and energy

Typical applications include helicopter rotor lead lag dampers. Some examples are given in **figure 3**.

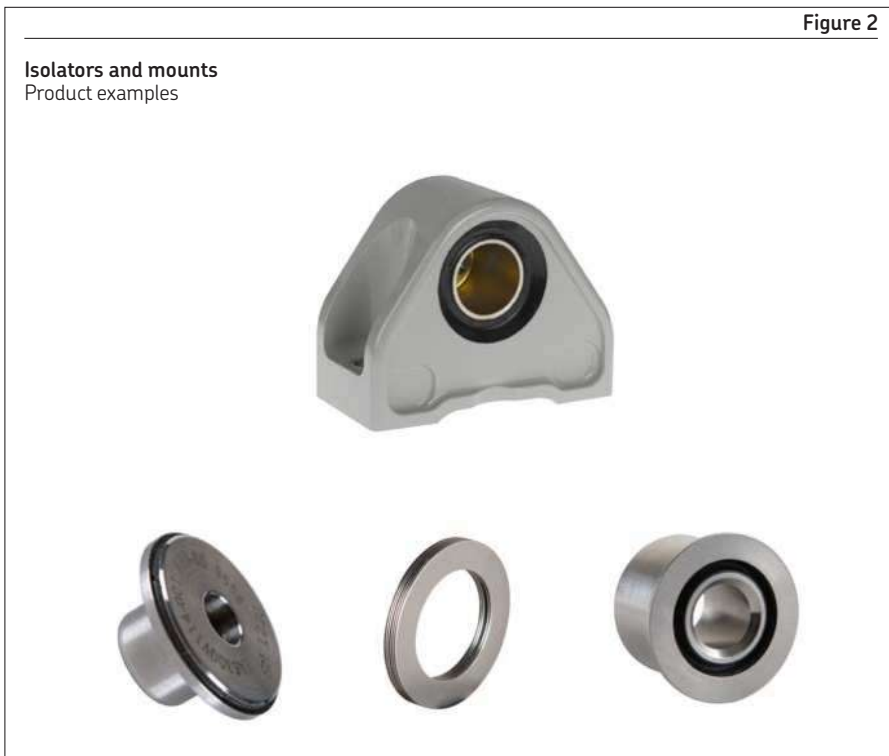

D Index

Text index 482
Table index 490

Text index

Symboler

Δdmp, see tolerances 45, 140, 149
ΔDmp, see tolerances 45, 140, 149
Δds, see tolerances 45, 140, 149
ΔDs, see tolerances 45, 140, 149
11AN..., see legacy products 151
11AW..., see legacy products 151
11BN.. 238
11BN..., see cross-reference to legacy products 151
11BW.. 151, 248, 249, 250, 251
11BW..., see cross-reference to legacy products 151
11C..E.. 216, 220
11C..E..., see cross-reference to legacy products 151
11C..N.. 214, 216
11C..N..., see cross-reference to legacy products 151
11C..W.. 216, 220
11C..W..., see cross-reference to legacy products 151
11E..H 224
11E..H, see cross-reference to legacy products 151
11F..E.. 216, 220
11F..E..., see cross-reference to legacy products 151
11F..N.. 214, 216
11F..N..., see cross-reference to legacy products 151
11F..W.. 216
11F..W..., see cross-reference to legacy products 151
11HN.. 238
11HN..., see cross-reference to legacy products 151
11HW.. 248
11HW..., see cross-reference to legacy products 151
11LBN.. 242
11LBN..., see cross-reference to legacy products 151
11LBW.. 252
11LBW..., see cross-reference to legacy products 151
11LHN.. 242
11LHN..., see cross-reference to legacy products 151
11LHW.. 252
11LHW..., see cross-reference to legacy products 151
12BF.. 358
12BF..., see cross-reference to legacy products 295
12BM.. 344
12BM..., see cross-reference to legacy products 295
12BNF.. 366
12BNF..., see cross-reference to legacy products 295

12BNM.. 348
12BNM..., see cross-reference to legacy products 295
12CF.. 362
12CF..., see cross-reference to legacy products 295
12CM.. 346
12CM..., see cross-reference to legacy products 295
12CNF.. 368
12CNF..., see cross-reference to legacy products 295
12CNM.. 350
12CNM..., see cross-reference to legacy products 295
15-5PH
 Customized products 141
15CDV6, see material 46
16NCD13 286
16NCD13, see material 437
17-4PH, see material 46, 139, 148, 289, 291, 395, 401, 460
30NCD16, see material 289, 291
32CDV13, see material 449
32CrMoV13, see material 449
40NCD7, see material 291
80MoCrV42-16, see material 449
100Cr6 (100C6), see material 46, 138, 286, 432, 437, 449, 460
431, see material 46, 286, 401, 437
440C, see material 46, 138, 139, 148, 286, 291, 432, 437, 449, 457, 460, 466
2024, see material 395, 401, 431
2618, see material 395, 401
4340, see material 291
9310, see material 449
9315, see material 286, 437
52100, see material 46, 138, 286, 437, 449, 460
..SN, see legacy products 151
..SW, see legacy products 151

A

ABS0576
 Spherical plain bearings 148
ABS2171, see customer standards 403
ABS2172, see customer standards 403
ABS2173, see customer standards 403
ABS2174, see customer standards 403
Adjustable rod, see engineered composite solutions 441
Aeroengine bearings 445
AGS3808, see legacy standards 403
AGS3809, see legacy standards 403
AGS3810, see legacy standards 403
AGS3811, see legacy standards 403
Airframe solutions 15
Alloy steel, see material 46, 47, 286, 289, 291, 431, 437
Aluminium alloy, see customized products 150
Aluminium alloy, see material 392, 401, 431
AMS03-19, see surface treatments 139, 149, 290, 292, 401, 437
AMS03-25, see surface treatments 401, 432
AMS 2417, see surface treatments 46, 139, 149, 292, 432, 437
AMS 2460, see surface treatments 139, 149
AMS 2700, see surface treatments 46, 139, 149, 292, 437
AMS 4533, see material 138, 139
AMS 4535, see material 138, 139
AMS 4640, see material 139
AMS 4643, see material 139, 289, 291
AMS 4928, see material 289, 291
AMS 5618, see material 46, 138, 139, 432, 437, 449
AMS 5628, see material 46, 286, 437
AMS 5629
 Customized products 141
 Material 291
AMS 5629, see material 148
AMS 5630, see material 46, 138, 139, 148, 432, 437, 460
AMS 5643 148
AMS 5643, see material 46
AMS 5659
 Customized bearings 141
AMS 5749, see products 449
AMS 5925, see material 449
AMS 6263, see material 286, 437
AMS 6278, see material 449
AMS 6415, see material 291
AMS 6440, see material 46, 138, 432, 437
AMS 6444, see material 46, 138, 432, 437, 449
AMS 6481, see material 449
AMS 6491, see material 449
AMS 7310, see material 471
AMS-QQ-A-200/3, see material 401
AMS-QQ-A-225/6, see material 401
AMS-QQ-P-146, see surface treatments 139
AMS-QQ-P-416, see surface treatments 149, 286, 290, 292, 401
AMS-S-5000, see material 291
Angled head
 Rod ends 293
Angular contact ball bearing, see customized bearings for aeroengine solutions 445
Angular contact bearing
 Aerospace thin section bearings 458
Anti-rotation features
 Customized bearings for aeroengine solutions 448
 Customized products for Airframe metal-to-metal spherical plain bearings 141
 Customized products for Airframe rod ends 295
 Customized products for Spherical plain bearings 150
 Groove and keyway for Airframe rod ends 293

Application

- Aerospace sealing solutions 471
- Aerospace specialty and engineered balls 464
- Aerospace thin section bearings 456
- Airframe solutions 15
- Customized bearings for aeroengine solutions 446
- Engineered composite solutions 440
- Engineered needle bearings 436
- Engineered pulleys 430
- Rod ends 282
- Rolling bearings 32
- Self-lubricating journal bearings 392
- Spherical plain bearings 128
- AP., see pulley 51
- AS 7034
 - Engineered pulleys 431
- AS 7034, see legacy products 432
- AS 14101 21, 143, 236, 238
- AS 14102 21, 143, 248
- AS 14103 21, 143, 248
- AS 14104 21, 143, 236, 238
- AS 15001
 - Rod ends 289
- AS 21151 24, 283, 332
- AS 21153 24, 283, 334
- AS 21154 19, 133, 186
- AS 21155 19, 133, 186
- AS 21230, see legacy standards 151
- AS 21231, see legacy standards 151
- AS 21232, see legacy standards 151
- AS 21233, see legacy standards 151
- AS 21428 17, 33, 92
- AS 21443, see pulley 51
- AS 27640 17, 33, 78
- AS 27641 17, 33, 80
- AS 27642 17, 33, 84
- AS 27643 17, 33, 114
- AS 27644 17, 33, 98
- AS 27645 17, 33, 106
- AS 27646 17, 33, 92, 94
- AS 27647 17, 33, 100
- AS 27648 17, 33, 102
- AS 81819
 - Spherical plain bearings 148
- AS 81820
 - Self-lubricating journal bearings 394
 - Spherical plain bearings 144, 148
- AS 81820/1 21, 143, 240, 242
- AS 81820/2 21, 143, 252
- AS 81820/3 21, 143, 252
- AS 81820/4 21, 143, 240, 242
- AS 81934
 - Self-lubricating journal bearings 394
 - Spherical plain bearings 148
- AS 81934/1 26, 393
- AS 81934/2 26, 393
- AS 81935
 - Rod ends 293
 - AS 81935/1 24, 283, 344
 - AS 81935/2 24, 283, 358
 - AS 81935/4 24, 283, 348
 - AS 81935/5 24, 283, 366
 - AS 81935/6 24, 283, 346
 - AS 81935/7 24, 283, 362
 - AS 81935/8 24, 283, 350
 - AS 81935/9 24, 283, 370
 - AS 81936/1 19, 133, 206
 - AS 81936/2 19, 133, 206
 - AS 82819
 - Spherical plain bearings 148
- ASNA2121, see customer standards 151
- ASNA2122, see customer standards 151
- ASNA2123, see customer standards 151
- ASNA2124, see customer standards 151
- ASNA2127, see customer standards 403
- ASNA2128, see customer standards 403
- ASTM A-295, see material 460
- Axial internal clearance
 - Rolling bearings 47
 - Spherical plain bearings 136

Axial load

- Aerospace thin section bearings 457
- Customized bearings for aeroengine solutions 447
- Rolling bearings 35
- Self-lubricating journal bearings 395
- Spherical plain bearings 134
- Axial load factor
 - Rolling bearings 38
- Axial location
 - Rolling bearings 42
- Axial projected area Aa
 - Spherical plain bearings 144
- Axial static limit load Ca
 - Rod ends 292
 - Rolling bearings 37
 - Self-lubricating journal bearing 395
 - Spherical plain bearings 134, 144
- Axial translation
 - Spherical plain bearings 128
- Axle
 - Rolling bearings 51
- Aerospace elastomeric and damping solutions 476

B

- BACB28AB, see customer standards 403
- BACB28AV, see customer standards 403
- BACB28AY, see customer standards 403
- BACB28BF, see customer standards 403
- Ball grades
 - Aerospace specialty and engineered balls 467
- Ballpin
 - Spherical plain bearings 150
- Ball plugs, see aerospace specialty and engineered balls 465
- Ball(s)
 - Aerospace specialty and engineered balls 464
 - Aerospace thin section bearings 458
 - Rolling bearings 32
 - Terminology 32
- BAS7661, see legacy standards 403
- BAS7662, see legacy standards 403
- BAS7663, see legacy standards 403
- BAS7664, see legacy standards 403
- Basic radial static limit load Co
 - Rolling bearings 37
- BB series
 - Aerospace thin section bearings 461
- BCA1..M, see legacy products 403
- BCA1..., see legacy products 403
- BCA2..M, see legacy products 403
- BCA2..., see legacy products 403
- Bearing designs
 - Aerospace thin section bearings 457
 - Customized bearings for aeroengine solutions 447
 - Engineered composite solutions 440
 - Engineered needle bearings 436
 - Engineered pulleys 430
 - Rod ends 282
 - Rolling bearings 32
 - Self-lubricating journal bearings 392
 - Spherical plain bearings 132, 142
- Bearing functions
 - Aerospace thin section bearings 457
 - Customized bearings for aeroengine solutions 447
 - Engineered composite solutions 440
 - Engineered needle bearings 436
 - Engineered pulleys 430
 - Rod ends 282
 - Rolling bearings 32
 - Self-lubricating journal bearings 392
 - Spherical plain bearings 132, 142
- Bearing geometries
 - Aerospace thin section bearings 457
 - Bearing functions 436
 - Customized bearings for aeroengine solutions 447
 - Engineered composite solutions 440
 - Engineered pulleys 430
 - Rod ends 282
 - Rolling bearings 32
 - Self-lubricating journal bearings 392
 - Spherical plain bearings 132, 142
- Bearing life
 - Engineered needle bearings 436
 - Rolling bearings 39
 - Self-lubricating journal bearings 394
 - Spherical plain bearings 144
- Bearing-pulley body bond strength static load
 - Engineered pulleys 431
- Bearing series
 - Aerospace thin section bearings 457
 - Customized bearings for aeroengine solutions 447
 - Engineered composite solutions 440
 - Engineered needle bearings 436
 - Engineered pulleys 430
 - Rod ends 282
 - Rolling bearings 32
 - Self-lubricating journal bearings 392
 - Spherical plain bearings 132, 142
- Bearing steel, see material 46, 138, 432, 437
- Bearing types
 - Aerospace thin section bearings 457
 - Airframe introduction 28
 - Rolling bearings 35
 - Spherical plain bearings 129
- Bearing variants
 - Customized bearings for aeroengine solutions 447
 - Engineered composite solutions 440
 - Engineered needle bearings 436
 - Engineered pulleys 430
 - Rod ends 282
 - Rolling bearings 34
 - Self-lubricating journal bearings 392
 - Spherical plain bearings 132, 142
- BFA1..., see legacy products 403
- BFA2..., see legacy products 403
- BFA-A-, see legacy products 403
- BFA-C-, see legacy products 403
- BG42, see material 449
- BLA1..M, see legacy products 403
- BLA1..., see legacy products 403
- BLA2..M, see legacy products 403
- BLA2..., see legacy products 403
- Body, see shell 392
- Bolted plate
 - Spherical plain bearings 155
- Bolt holes
 - Self-lubricating journal bearings 403
- Boots, see aerospace sealing solutions 469
- Bore diameter d
 - Self-lubricating journal bearings 395
- Bore motion, see dynamic loading condition 135
- BPA1..., see legacy products 403
- BPA2..., see legacy products 403
- BPA-A-, see legacy products 403
- BPA-C-, see legacy products 403
- Brass, see material 449, 461
- Bronze aluminium, see material 139
- Bronze beryllium, see material 138
- Bronze, see material 129, 131
- Bronze/steel, see sliding contact surface combination 131, 135
- Bump stops
 - Rod ends 295
 - Spherical plain bearings 141, 150

C

C-13MoCrNiV40, see material 449
C25
Spherical plain bearings 145
Cable
Engineered pulleys 430
Cadmium, see surface treatments 46, 139, 149, 286, 290, 292, 396, 401, 432, 437, 441
Cage
Aerospace thin section bearings 459
Customized bearings for aeroengine solutions 447
Engineered pulleys 430
Rolling bearings 51
Carbon fibre
Customized bearings for aeroengine solutions 450
Engineered composite solutions 440
Carbon seals, see aerospace sealing solutions 469
Carbon, see material 470
Carburized, see material 449
Case hardening alloy steel, see material 286, 437
Case hardening corrosion-resistant steel, see material 286, 437
Case hardening steel
Engineered needle bearings 437
Rolling bearings 51
Cassette seals, see aerospace sealing solutions 469
CDA..R, see legacy products 403
CDA..., see legacy products 403
Ceramic
Aerospace specialty and engineered balls 466
Aerospace thin section bearings 457
Customized bearings for aeroengine solutions 449
Rolling bearings 51
Chemical conversion
Self-lubricating journal bearings 403
Chemical passivation
Engineered needle bearings 437
Rod ends 292
Rolling bearings 51
Self-lubricating journal bearings 401
Spherical plain bearings 149
Chemical passivation, see surface treatments 139
Chromate, see surface treatments 46, 432
Chromex40, see material 449
Chromic acid anodizing
Self-lubricating journal bearings 403
Chromium 6, see surface treatments 46, 51, 139, 141, 149, 150, 286, 290, 292, 401, 403, 432
Chromium, see surface treatments 139, 149, 151, 396, 403, 461
Circlip groove
Self-lubricating journal bearings 403
Coating
Aerospace thin section bearings 461
Spherical plain bearings 148
Cobalt alloys
Spherical plain bearings 141
Combined loads
Rolling bearings 38
Spherical plain bearings 134
Compactness
Aerospace thin section bearings 460
Customized bearings for aeroengine solutions 446
Engineered pulleys 430
Rolling bearings 36
Composite 439
Conduction braid
Engineered composite solutions 440

Contacts II
Contaminants
Aerospace elastomeric and damping solutions 478
Aerospace thin section bearings 460
Customized bearings for aeroengine solutions 449
Rolling bearings 40
Spherical plain bearing 140, 149
Spherical plain bearings 131, 145
Controlled clearance, see bearing functions 142, 147, 152
Corrosion resistance
Rod ends 286
Spherical plain bearings 131
Corrosion resistance, see material 46, 148, 286, 290
Corrosion resistance, see surface treatments 46, 139, 149
Corrosion-resistant high nitrogen steel (CREN)
Rolling bearings 51
Corrosion-resistant steel, see material 46, 138, 139, 148, 286, 289, 290
Counterbore
Spherical plain bearings 141, 150
Counterface
Self-lubricating journal bearing 396
CRES, see material 401
Crimping ring
Engineered pulleys 431
Cross-reference
Rod ends 382
Rolling bearings 118
Self-lubricating journal bearings 426
Spherical plain bearings 268
Cross-reference to legacy products
Rod ends 295
Spherical plain bearings 151
CuAl10Ni5Fe4, see material 139
CuBe 1.9, see material 138, 139
Customer standards
Self-lubricating journal bearings 403
Spherical plain bearings 151
Customized products
Rod ends 295
Rolling bearings 51
Self-lubricating journal bearings 403
Spherical plain bearings 141, 150
Cylindrical roller bearing, see customized bearings for aeroengine solutions 445
Cobalt alloys
Aerospace specialty and engineered balls 466

D

Dampers, see customized bearings for aeroengine solutions 448
Dampers, see elastomeric and damping solutions 477
Damping solutions 477
Deep-groove ball bearing, see customized bearings for aeroengine solutions 445
Deep groove ball bearing, see engineered pulleys 430
Deep groove ball bearing, see rolling bearings 31
Deep groove ball bearing with self-aligning ring, see rolling bearings 31
Deflection
Aerospace elastomeric and damping solutions 478
Self-lubricating journal bearings 394
Spherical plain bearings 144
DEF STAN 03-19, see surface treatments 139, 149, 290, 292, 401, 437
DEF STAN 03-25, see surface treatments 401, 432
Design features
Aerospace thin section bearings 457
Customized bearings for aeroengine solutions 448
Rod ends 284
Spherical plain bearings 130
Deviation of a single bore diameter, see tolerances 45, 140, 149
Deviation of a single outside diameter, see tolerances 45, 140, 149
Diagonal internal clearance
Rolling bearings 47
Diaphragm seals, see aerospace sealing solutions 469
Dismounting
Rod ends 294
Rolling bearings 50
Self-lubricating journal bearings 402
Spherical plain bearings 155
Dismounting grooves
Customized bearings for aeroengine solutions 448
DJA..R, see legacy products 403
DJA., see legacy products 403
Double ended links
Rod ends 295
Double fork end
Engineered composite solutions 441
Double journal bearings
Self-lubricating journal bearings 403
Double row bearing, see customized bearings for aeroengine solutions 447
Double row bearing, see engineered needle bearings 436
Double row bearing, see engineered pulleys 430
Double row bearing, see rod ends 285
Double row bearing, see rolling bearings 31
Download II
Dry film lubrication
Self-lubricating journal bearings 403
Dry lubricants
Spherical plain bearings 139
DTD 5014 TF, see material 395, 401
Dynamic load
Engineered pulleys 431
Rod ends 292
Rolling bearings 38
Spherical plain bearings 135, 144
Dynamic load for rod ends with inserted bearings
Rod ends 292
Dynamic loading condition
Spherical plain bearings 135
Dynamic load rating
Rolling bearings 38
Self-lubricating journal bearings 394
Spherical plain bearings 135, 144
Dynamic operating load P
Rolling bearings 39
Dynamic radial load
Engineered needle bearings 436
Dynamic rotational torque, see rotational frictional moment 146
Dynamic wear limit
Self-lubricating journal bearings 394
Spherical plain bearings 144

E

3490, see material 46
EASA Part 145, see remanufacturing 450
ECOPUR, see material 470
Elastomeric bearings, see elastomeric and damping solutions 477
Elastomeric solutions 477
EN 2009, see legacy standards 51
EN 2010, see legacy standards 51
EN 2011, see legacy standards 51
EN 2012, see legacy standards 51
EN 2013, see legacy standards 51
EN 2014, see legacy standards 51
EN 2015, see legacy standards 51
EN 2016, see legacy standards 51
EN 2017, see legacy standards 51
EN 2018, see legacy standards 51
EN 2019, see legacy standards 51
EN 2020, see legacy standards 51
EN 2030, see material 46, 138, 139, 148, 432, 437
EN 2031, see material 46, 138, 432, 437
EN 2062
 Engineered pulleys 431
EN 2062, see legacy products 432
EN 2081, see legacy products 432
EN 2099, see material 286, 437
EN 2137, see material 289, 291
EN 2249, see material 46
EN 2285 26, 393, 404
EN 2286 26, 393, 408
EN 2287 26, 393, 404
EN 2288 26, 393, 408
EN 2318, see material 401
EN 2335 19, 133, 168
EN 2336 19, 133, 156
EN 2475, see material 289, 291
EN 2498 23, 283, 312
EN 2539, see material 46, 139, 148, 289, 291
EN 2584 20, 143, 216
EN 2585 20, 143, 220
EN 2588 19, 133, 156
EN 2701, see material 401
EN 2704, see material 401
EN 2755
 Self-lubricating journal bearings 394
 Spherical plain bearings 144
EN 3045 17, 33, 54
EN 3046 17, 33, 54
EN 3047 17, 33, 54
EN 3048 20, 143, 214
EN 3053 17, 33, 72
EN 3054 17, 33, 72
EN 3055 17, 33, 72
EN 3056 17, 33, 62
EN 3057 17, 33, 62
EN 3058 17, 33, 62
EN 3059 17, 33, 64
EN 3060 17, 33, 64
EN 3061 17, 33, 64
EN 3182, see pulley 51
EN 3281 17, 33, 58
EN 3282 17, 33, 58
EN 3283 17, 33, 58
EN 3284 17, 33, 54
EN 3285 17, 33, 54
EN 3286 17, 33, 54
EN 3287 17, 33, 68
EN 3288 17, 33, 68
EN 3289 17, 33, 68
EN 3290 17, 33, 74
EN 3291 17, 33, 74
EN 3292 17, 33, 74
EN 3311, see material 289, 291
EN 3490, see material 46, 286, 401, 437
EN 3541 23, 283, 296
EN 3629, see pulley 51

EN 4033 17, 33, 58
EN 4034 17, 33, 70
EN 4036 23, 283, 296
EN 4037 20, 143, 214
EN 4038 20, 143, 216
EN 4039 20, 143, 220
EN 4040 20, 143, 224
EN 4041 17, 33, 66
EN 4156 24, 283, 326
EN 4157 24, 283, 326
EN 4198 23, 283, 312
EN 4265 19, 133, 198
EN 4266 19, 133, 198
EN 4351, see legacy standards 295
EN 4534-2 26, 393
EN 4535-2 26, 393
EN 4536-2 26, 393
EN 4537-2 26, 393
EN 6046 19, 133, 190, 192
End of life criteria
 Spherical plain bearings 135
Endurakote, see coatings 461
Endurance
 Rod ends 292
 Spherical plain bearings 144
Endurance dynamic load CE
 Engineered pulleys 431
Endurance, see dynamic loading condition 135, 144, 292
Endura-Slim
 Aerospace thin section bearings 457
Equivalent radial static load Ps
 Rolling bearings 38
External thread
 Rod end body features 293
 Rod ends 282
 Terminology 282

F

Fatigue
 Rod ends 292
 Spherical plain bearings 135, 144
Fatigue load carrying capability Pmax
 Rod ends 292
Fatigue, see dynamic loading condition 135, 144, 292
Fatigue, see material 401
Features
 Rod ends 293
Female thread, see internal thread 282
Fiberslip 404, 412, 418
 Liner 150, 392
 Self-lubricating journal bearings 403
 Spherical plain bearings 150
Fit
 Engineered needle bearings 437
 Rolling bearings 42
 Self-lubricating journal bearings 396
 Spherical plain bearings 152
Flange
 Customized bearings for aeroengine solutions 448
 Rolling bearings 32
 Spherical plain bearings 141, 150
 Terminology 32
Flanged bearing
 Rolling bearings 44
Flanged bearing, see self-lubricating journal bearings 391
Flange diameter A
 Self-lubricating journal bearings 395
Flanged units
 Rolling bearings 44
Flange width F
 Self-lubricating journal bearings 395

Flatted balls, see aerospace specialty and engineered balls 463
Fluid handling seals, see aerospace sealing solutions 469
Fork end
 Engineered composite solutions 440
Four-point contact bearing
 Aerospace thin section bearings 458
Fretting resistance, see fit 402
Fretting resistance, see surface treatments 46, 131, 139, 149, 286, 401, 432, 437
Friction coefficient μ
 Spherical plain bearings 146
Full complement 32
Fiberslip 408

G

G353, see lubrication 136
G354, see lubrication 39, 136, 285, 288, 432, 437
G395, see lubrication 39, 136, 285, 288, 432, 437
Gap, see split inner ring 132
Glass fibre
 Customized bearings for aeroengine solutions 450
 Engineered composite solutions 440
 Engineered pulleys 431
 Rolling bearings 47
Glass, see material 466
Graphite lubricants, see dry lubricants 139
Greased-for-life
 Rod ends 288
 Rolling bearings 28
 Spherical plain bearings 137
Grease fitting
 Rod ends 282
 Terminology 282
Grease input, see lubrication grooves 137, 289
Grease, see lubrication 39, 137, 285, 288, 431, 437
Groove
 Engineered pulleys 430
Groove flange strength static load CB
 Engineered pulleys 431
Guide rings, see aerospace sealing solutions 469

H

Hard anodizing
 Self-lubricating journal bearings 403
Hard chromium plating
 Self-lubricating journal bearings 403
Hard chromium, see coatings 461
Hard chromium, see surface treatments 139, 149, 396
Hardness, see material 46, 138, 139, 148, 286, 289, 291, 396, 432, 460, 466
Head shape
 Rod ends 293
High frequency motion
 Rod ends 282
High frequency oscillation
 Spherical plain bearings 131
High load, see bearing functions 132
High misalignment, see bearing functions 21, 132, 143
High speed
 Customized bearings for aeroengine solutions 446

High temperature
 Aerospace carbon seals for turbine engines 471
 Aerospace elastomeric and damping solutions 479
 Aerospace thin section bearings 460
 Customized bearings for aeroengine solutions 449
 Customized products 51, 141
 Rolling bearings 51
 Sealing rings 471
 Spherical plain bearings 141
 Hollow balls, see aerospace specialty and engineered balls 463
 Horizontal groove, see locating groove 282
 Hybrid bearings
 Aerospace thin section bearings 460
 Hydraulic seals, see aerospace sealing solutions 469

I
 Increased internal clearance
 Engineered pulleys 431
 Rolling bearings 48
 Inner ring
 Aerospace thin section bearings 458
 Rolling bearings 32
 Spherical plain bearings 128
 Terminology 32, 128
 Inner ring side run-out with raceway, see tolerances 45
 Insert
 Engineered composite solutions 441
 Inserted spherical plain bearing
 Rod ends 282
 Terminology 282
 Integrated axle
 Engineered needle bearings 436
 Rolling bearings 51
 Integrated metal-to-metal spherical plain bearing
 Rod ends 282
 Terminology 282
 Integrated rolling bearing
 Rod ends 282
 Terminology 282
 Interfaces
 Rolling bearings 42
 Spherical plain bearings 152
 Internal clearance
 Aerospace thin section bearings 457
 Engineered pulleys 431
 Rod ends 289
 Rolling bearings 47
 Spherical plain bearings 136, 147
 Internal thread
 Rod ends 282
 Terminology 282
 ISO 8075, see surface treatments 46, 139, 149
 Isolators, see elastomeric and damping solutions 477

J
 JN..C, see pulley 51
 Jointing compound
 Spherical plain bearings 153
 Journal bearings, see self-lubricating journal bearings 25

K
 Kea, see tolerances 45
 Keyway
 Rod ends 282
 Terminology 282
 Kia, see tolerances 45
 KT series
 Aerospace thin section bearings 461

L
 L10 life
 Rolling bearings 39
 L50 life
 Rolling bearings 38
 Left-hand thread
 Rod ends 293
 Legacy products
 Engineered pulleys 432
 How to use the catalogue 13
 Rod ends 295
 Self-lubricating journal bearings 403
 Spherical plain bearings 151
 Legacy standards
 How to use the catalogue 13
 Rod ends 295
 Rolling bearings 51
 Spherical plain bearings 151
 Length to back face of flange L
 Self-lubricating journal bearings 395
 Light, see bearing geometries 132, 142
 Lightweight
 Aerospace elastomeric and damping solutions 478
 Aerospace specialty and engineered balls 466
 Aerospace thin section bearings 461
 Customized bearings for aeroengine solutions 449
 Engineered composite solutions 440
 Rod ends 289, 291
 Self-lubricating journal bearings 392, 401
 Spherical plain bearings 141, 150
 Limit of usable liner thickness, see end of life criteria 145
 Lined bore
 Rod ends 292
 Self-lubricating journal bearings 392
 Spherical plain bearings 150
 Liner
 Self-lubricating journal bearings 392, 401
 Spherical plain bearings 128
 Terminology 128, 392
 Liner in bore
 Spherical plain bearings 141
 Liquid nitrogen, see material 466
 Liquid nitrogen, see mounting 153, 402
 Liquid nitrogen, see operating temperature 147, 394
 Load carrying capability
 Customized bearings for aeroengine solutions 447
 Engineered composite solutions 440
 Engineered needle bearings 436
 Engineered pulleys 431
 Rod ends 292
 Rolling bearings 37
 Self-lubricating journal bearings 394
 Spherical plain bearings 134, 144

Loaded frictional moment T
 Spherical plain bearings 146
 Loader slot
 Spherical plain bearings 132
 Load-life relationship
 Rolling bearings 39
 Locating groove
 Rod ends 282
 Terminology 282
 Locating locking hole
 Rod ends 293
 Locking device
 Engineered composite solutions 441
 Locking T-seals, see aerospace sealing solutions 469
 Lubrication
 Engineered needle bearings 437
 Engineered pulleys 431
 Rod ends 285, 288
 Rolling bearings 39
 Self-lubricating journal bearings 402
 Spherical plain bearings 137
 Lubrication grooves
 Customized bearings for aeroengine solutions 448
 Rod ends 289
 Rolling bearings 51
 Spherical plain bearings 128, 137, 141
 Terminology 128

M
 M50
 Aerospace specialty and engineered balls 466
 Aerospace thin section bearings 461
 Rolling bearings 51
 M50-NiL, see material 449, 466
 M50, see material 449, 461, 466
 Maintenance-free
 Self-lubricating journal bearings 28, 392
 Spherical plain bearings 28, 130
 Male thread, see external thread 282
 Manufacturing capabilities 10
 Master ball sets, see aerospace specialty and engineered balls 463
 Material
 Aerospace sealing solutions 470
 Aerospace specialty and engineered balls 466
 Aerospace thin section bearings 460
 Customized bearings for aeroengine solutions 449
 Engineered needle bearings 437
 Engineered pulleys 431
 Rod ends 286, 289, 291
 Rolling bearings 45
 Self-lubricating journal bearings 401
 Spherical plain bearings 138, 148
 Maximum allowable internal clearance limit, see end of life criteria 135, 145
 Metal, see material 470
 Metal-to-metal, see spherical plain bearings
 Rolling bearings 127
 Metal-to-metal spherical plain bearing rod end, see rod ends 281
 MIL-A-8625, see surface treatments 290, 401, 432
 MIL-DTL-7034/1, see legacy products 432

MIL-DTL-7034/2, see legacy products 432
 MIL-DTL-7034/3, see legacy products 432
 MIL G 21164, see lubrication 136
 MIL PRF 23827, see lubrication 39, 136, 285, 288, 432, 437
 MIL PRF 81322, see lubrication 39, 136, 285, 288, 432, 437
 Misalignment
 Customized bearings for aeroengine solutions 447
 Rolling bearings 36
 Spherical plain bearings 128
 Moment load
 Aerospace thin section bearings 457
 Customized bearings for aeroengine solutions 447
 MoS₂, see dry lubricants 139
 Mounting
 Engineered needle bearings 437
 Rod ends 294
 Rolling bearings 49
 Self-lubricating journal bearings 402
 Spherical plain bearings 153
 Mounts, see elastomeric and damping solutions 477
 M series
 Aerospace thin section bearings 460

N

Narrow, see bearing geometries 132, 142
 Needle bearings 435
 Needle roller bearing, see needle bearings 435
 Needle track roller bearing, see needle bearings 435
 Nickel alloys
 Aerospace specialty and engineered balls 466
 Spherical plain bearings 141
 Nitrided, see material 449, 466
 Nitriding
 Rolling bearings 51
 Nitriding, see surface treatments 437
 Nitrile rubber, see material 461
 Non-metallic materials, see material 47, 431, 461, 466, 471
 Notches
 Spherical plain bearings 141, 150
 NSA 8134 21, 143, 232
 NSA 8134, see customer standards 151
 NSA 8135 21, 143, 244
 NSA 8135, see customer standards 151
 NSA 8136 21, 143, 232
 NSA 8136, see customer standards 151
 NSA 8137 21, 143, 244
 NSA 8137, see customer standards 151
 NSA 8143 24, 283, 352
 NSA 8145 26, 393
 NSA 8146 26, 393
 NSA 8147 26, 393
 NSA 8148 26, 393
 NSA 8149 24, 283, 374
 NSA 8194, see customer standards 403
 NSA 8195, see customer standards 403
 Nut and washer design
 Rolling bearings 51
 Spherical plain bearings 141, 150
 Nylon, see material 466

O

Oil
 Customized bearings for aeroengine solutions 447
 Open bearings
 Aerospace thin section bearings 457
 Operating clearance
 Rolling bearings 48
 Spherical plain bearings 152
 Operating temperature
 Aerospace sealing solutions 470
 Aerospace thin section bearings 460
 Customized bearings for aeroengine solutions 449
 Engineered needle bearings 437
 Engineered pulleys 431
 Rod ends 285, 289, 291
 Rolling bearings 40
 Self-lubricating journal bearings 394
 Spherical plain bearings 138, 147
 Outer diameter D
 Self-lubricating journal bearings 395
 Outer race, see outer ring 32, 128, 458
 Outer ring
 Aerospace thin section bearings 458
 Rolling bearings 32
 Spherical plain bearings 128
 Terminology 32, 128
 Outer ring side run-out with raceway, see tolerances 45
 Oversize
 Rolling bearings 49
 Self-lubricating journal bearings 402
 Spherical plain bearings 155
 Overall width W
 Self-lubricating journal bearings 395

P

Paint
 Engineered composite solutions 440
 Rod ends 293
 PAN4832, see legacy standards 403
 PAN4833, see legacy standards 403
 PAN4834, see legacy standards 403
 PAN4835, see legacy standards 403
 PA., see legacy products 432
 PD..K, see pulley 51
 PEEK, see polyether ether ketone 450
 PEEK, see Polyether ether ketone 461, 470, 475
 Permanent set
 Self-lubricating journal bearings 394
 Spherical plain bearings 144
 PH13.8
 Customized products 141
 see material 141
 PH13.8, see material 291
 Phenolic laminate, see material 461
 PHUFJ/XRE., see cross-reference to legacy products 295
 PHUFJ/XRL., see cross-reference to legacy products 295
 PHUMJ/XRE., see cross-reference to legacy products 295
 PHUMJ/XRL., see cross-reference to legacy products 295
 Pin
 Spherical plain bearings 141, 150
 Piston seals, see aerospace sealing solutions 469
 P.K, see pulley 51
 Plain bearing, see self-lubricating journal bearings 391
 Plastic, see material 470
 P.MSP, see legacy products 432
 PNA., see legacy products 432
 PN., see legacy products 432
 PNU 219, see legacy products 432
 PNU 220, see legacy products 432
 PNU 221, see legacy products 432
 Pockets
 Spherical plain bearings 141, 150
 Polyether ether ketone, see material 450, 461, 470, 475
 Polyurethane, see material 470
 Precision
 Aerospace specialty and engineered balls 463
 Aerospace thin section bearings 456, 457
 Customized bearings for aeroengine solutions 446
 Engineered composite solutions 441
 Rolling bearings 48
 Precision bearings
 Aerospace thin section bearings 456
 Customized bearings for aeroengine solutions 446
 Rolling bearings 48
 Precision specialty balls
 Aerospace specialty and engineered balls 463
 Customized bearings for aeroengine solutions 448
 Rolling bearings 45
 Pre-loading
 Customized bearings for aeroengine solutions 447
 Pre-staked design
 Spherical plain bearings 141
 Terminology 130
 Product range
 Aerospace sealing solutions 470
 Elastomeric and damping solutions 478
 Rod ends 282
 Rolling bearings 32
 Self-lubricating journal bearings 392
 Spherical plain bearings 132, 142
 P., see legacy products 432
 P series
 Aerospace thin section bearings 460
 P.SP, see legacy products 432
 PTFE fibres, see liner 148, 401
 PTFE, see liner 130, 142, 401
 PTFE, see material 47, 457, 470
 Pulley 430
 Rolling bearings 51
 Pulley body
 Engineered pulleys 430
 Pushout load
 Spherical plain bearings 154
 PVD
 Rolling bearings 51
 Spherical plain bearings 141, 150

Q

Quality management 10

R

Radial contact bearing
Aerospace thin section bearings 458

Radial dynamic load rating C
Self-lubricating journal bearings 395

Radial internal clearance
Rolling bearings 47
Spherical plain bearings 136, 147

Radial load
Aerospace thin section bearings 457
Customized bearings for aeroengine solutions 447
Rolling bearings 37
Spherical plain bearings 134, 144

Radial projected area Ar
Spherical plain bearings 144

Radial run-out of assembled bearing inner ring, see tolerances 45

Radial run-out of assembled bearing outer ring, see tolerances 45

Radial shaft seals, see aerospace sealing solutions 469

Radial static limit load Cs
Rod ends 292
Rolling bearings 37
Self-lubricating journal bearings 395
Spherical plain bearings 144

Radial ultimate load
Rod ends 292
Rolling bearings 37
Spherical plain bearings 135, 144

Reduced clearance
Rolling bearings 48
Spherical plain bearings 136

Reduced torque
Spherical plain bearings 147

Reliability factor K
Rolling bearings 39

Relubricated
Rod ends 288
Spherical plain bearings 28

Relubrication
Engineered needle bearings 437
Rod ends 289
Rolling bearings 51
Spherical plain bearings 28, 137

Remanufacturing
Aerospace thin section bearings 461
Customized bearings for aeroengine solutions 450

Resin, see liner 148

Retainer
Rolling bearings 32
Terminology 32

Retaining compound
Self-lubricating journal bearings 402
Spherical plain bearings 153

Retention
Spherical plain bearings 154

Retention feature
Self-lubricating journal bearings 403

Right-hand thread
Rod ends 293

RL..SP., see cross-reference to legacy products 151

Rod and buffer seals, see aerospace sealing solutions 469

Rod end bearings 22

Rod end body
Rod ends 282
Terminology 282

Rod end body load carrying capability
Rod ends 292

Roller(s)
Rolling bearings 32
Terminology 32

Rolling bearing rod end, see rod ends 281

Rolling bearings 16

Rotary manifold seals, see aerospace sealing solutions 469

Rotating equipment performance 8

Rotation
Spherical plain bearings 128

Rotational frictional moment
Rolling bearings 41
Spherical plain bearings 146

Round head
Rod ends 293

Rubber, see material 470

S

S97, see material 289, 291

Seal
Spherical plain bearings 128
Terminology 128

Sealing rings, see aerospace sealing solutions 469

Sealing solutions 469
Rod ends 286, 290, 292
Rolling bearings 47
Spherical plain bearing 140, 149

Seals
Aerospace thin section bearings 460
Engineered pulleys 432
Rod ends 286, 290, 292
Rolling bearings 32, 40
Spherical plain bearings 140, 149
Terminology 32

Sea, see tolerances 45

Seizing resistance
Spherical plain bearings 131

Selection criteria
Rod ends 284
Rolling bearings 35
Spherical plain bearings 129, 131

Selection process 28
Engineered needle bearings 436
Engineered pulleys 430
Rolling bearings 36
Self-lubricating journal bearings 394
Spherical plain bearings 134, 142

Self-aligning ball bearing, see rolling bearings 31

Self-lubricating, see spherical plain bearings 127

Self-lubricating spherical plain bearing rod end, see rod ends 281

Shackle
Spherical plain bearings 141

Shank
Rod ends 282
Terminology 282

Shell
Self-lubricating journal bearings 392
Terminology 392

Shields
Aerospace thin section bearings 460
Engineered pulleys 432
Rod ends 286, 290, 292
Rolling bearings 32, 40
Spherical plain bearings 128, 140, 149
Terminology 32, 128

Sia, see tolerances 45

Silicon nitride, see material 466

Silicon, see material 461

Silver plating
Rolling bearings 51
Self-lubricating journal bearing 403
Spherical plain bearings 141, 150

Silver plating, see material 449

Single plane mean bore diameter deviation, see tolerances 45, 140, 149

Single plane mean outside diameter deviation, see tolerances 45, 149

Single row bearing, see rolling bearings 31

Size
Aerospace thin section bearings 456
Customized bearings for aeroengine solutions 448
Rod ends 285, 287, 291
Rolling bearings 36
Self-lubricating journal bearings 394
Spherical plain bearings 134, 142

SKF Black design composite fitting 439

SKF care 9

SKF Reali-Slim 456
Aerospace thin section bearings 456

SKF Reali-Slim TT series
Aerospace thin section bearings 461

SKF rolling bearings (industrial bearings) 10

SKF slewing ring bearings 10

SKF Spectraseal, see aerospace sealing solutions 469

SKF Speedi-Sleeve Gold, see aerospace sealing solutions 469

SKF Speedi-Sleeve, see aerospace sealing solutions 469

SKF super precision bearings 10

Sleeve
Spherical plain bearings 141

Sliding contact surface combination
Spherical plain bearings 129, 135

Slots, see loader slot 132

Specialty balls 463
Customized bearings for aeroengine solutions 447

Speed factor
Customized bearings for aeroengine solutions 447

Spherical plain bearings 18, 126

Spherical roller bearing, see customized bearings for aeroengine solutions 445

Spherical roller bearing, see rolling bearings 31

Split inner ring
Spherical plain bearings 132

Stainless steel, see material 46, 138, 139, 148, 291, 432, 437, 457, 460, 473

Staked lip
Self-lubricating journal bearings 403
Spherical plain bearings 141

Staking
Rod ends 289, 291
Rolling bearings 42
Spherical plain bearings 154

Staking groove
Rolling bearings 51
Spherical plain bearings 128
Terminology 128

Standard clearance
Spherical plain bearings 136

Starting torque
Rolling bearings 41
Spherical plain bearings 146

Static axial limit load Ca
Spherical plain bearings 144

Static limit load
Rod ends 292
Rolling bearings 37
Self-lubricating journal bearings 394, 395
Spherical plain bearings 134, 144

- Static load
 - Rod ends 292
 - Rolling bearings 37
 - Self-lubricating journal bearings 395
 - Spherical plain bearings 134
- Static radial limit load Cs
 - Rolling bearings 37
 - Self-lubricating journal bearings 395
 - Spherical plain bearings 134, 144
- Static radial load CR
 - Engineered needle bearings 436
 - Engineered pulleys 431
- Static ultimate load
 - Rod ends 292
 - Rolling bearings 37
- Steel/bronze, see sliding contact surface combination 135
- Steel/steel, see sliding contact surface combination 135
- Stiffness
 - Aerospace elastomeric and damping solutions 479
 - Aerospace specialty and engineered balls 466
 - Aerospace thin section bearings 458
 - Customized bearings for aeroengine solutions 447
 - Engineered composite solutions 440
 - Spherical plain bearings 136, 146
- Storage
 - Customized bearings for aeroengine solutions 450
 - Rod ends 294
 - Rolling bearings 50
 - Self-lubricating journal bearings 402
 - Spherical plain bearings 155
- Stress ratio R
 - Rod ends 292
- Structural fibres, see liner 148, 401
- Structural rod, see engineered composite solutions 439
- Sulfuric acid anodizing, see surface treatments 401, 432
- Surface treatments
 - Engineered needle bearings 437
 - Engineered pulleys 432
 - Rod ends 286, 290, 292
 - Rolling bearings 46
 - Self-lubricating journal bearings 401
 - Spherical plain bearings 139, 149
- Swaged
 - Spherical plain bearings 132, 142
- Swivelling
 - Rolling bearings 32
 - Spherical plain bearings 128, 146
- Swivelling frictional moment 28
- Self-lubricating journal bearings 390
- Single plane mean outside diameter deviation, see tolerances 140
- Relubricated 137
- Stainless steel, see material 449
- Static ultimate load
 - Spherical plain bearings 135
- Swivelling frictional moment
 - Rolling bearings 41

T

- TA6V, see material 289, 291
- Tapered roller bearing, see aerospace thin section bearings 461
- Tapered roller bearings, see customized bearings for aeroengine solutions 445
- Tartaric sulfuric anodizing
 - Self-lubricating journal bearings 403

- Tear drop head
 - Rod ends 293
- Tensile strength (Rm), see material 286, 289, 291
- Textilub
 - Self-lubricating journal bearings 403
 - Spherical plain bearings 150
- Thermal expansion
 - Customized bearings for aeroengine solutions 448
 - Engineered composite solutions 440
 - Rolling bearings 42
 - Spherical plain bearings 136, 147
- Thermoplastic elastomers, see material 470
- Thin section bearings 455
- Threaded plate
 - Spherical plain bearings 155
- Thread type
 - Rod ends 293
- Three and four-point contact ball bearings, see customized bearings for aeroengine solutions 445
- Through hardened, see material 449, 466
- Thrust washer, see liner 392
- Ti6Al4V, see material 289, 291
- Titanium alloy, see customized products 141, 150, 295, 403
- Titanium alloy, see material 289, 291, 396, 466
- Tolerances
 - Customized bearings for aeroengine solutions 448
 - Rolling bearings 45
 - Self-lubricating journal bearings 396
 - Spherical plain bearings 140, 149
- Tooling and checking balls, see aerospace specialty and engineered balls 463
- Tool steel, see material 466
- Torque
 - Rod ends 285, 291
 - Rolling bearings 41
 - Self-lubricating journal bearings 394
 - Spherical plain bearings 146
- TPU, see material 470
- Tube
 - Engineered composite solutions 440

U

- UFJ/XRE..., see cross-reference to legacy products 295
- UFJ/XRL..., see cross-reference to legacy products 295
- Ultimate static loads
 - Spherical plain bearings 135
- Ultra-Slim thin section bearings
 - Aerospace thin section bearings 461
- UMJ/XRE..., see cross-reference to legacy products 295
- UMJ/XRL..., see cross-reference to legacy products 295
- Units 6
- Universal joint
 - Engineered composite solutions 441
- Unlined journal bearings
 - Self-lubricating journal bearings 403
- Unloaded torque
 - Spherical plain bearings 146
- Use cases 13

V

- Vertical groove, see keyway 282, 293
- Viton, see material 461

W

- Wear rate
 - Spherical plain bearings 145
- Wear resistance
 - Spherical plain bearings 131
- Wear-resistant coating
 - Engineered pulleys 432
- Wear sleeves, see aerospace sealing solutions 469
- Wide, see bearing geometries 132, 142
- Wiper seals, see aerospace sealing solutions 469

X

- X1
 - Self-lubricating journal bearings 392, 403
 - Spherical plain bearings 148
- X1-40
 - Self-lubricating journal bearings 392
 - Spherical plain bearings 148
- X40CrMoVN16.2, see material 449
- X105CrMo17, see material 46, 138, 139, 432, 437, 449
- XCR, see surface treatments 139, 149
- XLHP, see coating 148
- XLNT, see coating 148
- XL, see coating 148
- XRA..., see cross-reference to legacy products 151
- XRE...A..., see cross-reference to legacy products 151
- XRE..., see cross-reference to legacy products 151
- XRL..., see cross-reference to legacy products 151

Z

- Z6CNU17.04, see material 46, 139, 148, 289, 291
- Z15CN17.03, see material 46, 286, 437
- Z100CD17, see material 46, 138, 139, 148, 432, 437, 449
- Zinc-nickel, see surface treatments 46, 139, 149, 286, 290, 292, 401

Table index

11BH..

13ASF..

Designation	Product	Product table No. Page ¹⁾	Designation	Product	Product table No. Page ¹⁾
11BH..	Airframe spherical plain bearings – Self-lubricating high misalignment (inch dimensions), no coating	2.32 258	11LBN..	For the cross-reference designation of this legacy product, see NAS..A..	
11BN..	For the cross-reference designation of this legacy product, see NAS..		11LBW..	For the cross-reference designation of this legacy product, see WAS..A..	
11BW..	For the cross-reference designation of this legacy product, see WAS..		11LHN..	For the cross-reference designation of this legacy product, see NAS..A..	
11C..E.. for bore code 5	For the cross-reference designation of this legacy product, see WEN..		11LHW..	For the cross-reference designation of this legacy product, see WAS..A..	
11C..E.. for bore code 8 and ≥ 12 (except 2 ²⁾)	For the cross-reference designation of this legacy product, see NEN..		11NH..	Airframe spherical plain bearings – Self-lubricating high misalignment (inch dimensions), XLNT coated sphere	2.32 258
11C..N.. for bore code ≥ 12	For the cross-reference designation of this legacy product, see LEN..		12BF..	For the cross-reference designation of this legacy product, see FJ/WAS.., EFJ/WAS.., SFJ/WAS.., SEFJ/WAS..	
11C..N.. for bore codes 6 and 10	For the cross-reference designation of this legacy product, see NEN..		12BM..	For the cross-reference designation of this legacy product, see MJ/WAS.., EMJ/WAS.., SMJ/WAS.., SEMJ/WAS..	
11C..W.. for bore code ≥ 6	For the cross-reference designation of this legacy product, see WEN..		12BNF..	For the cross-reference designation of this legacy product, see FJ/NAS.., EFJ/NAS.., SFJ/NAS.., SEFJ/NAS..	
11C..W.. for bore codes 5 and 22	For the cross-reference designation of this legacy product, see NEN..		12BNM..	For the cross-reference designation of this legacy product, see MJ/NAS.., EMJ/NAS.., SMJ/NAS.., SEMJ/NAS..	
11DH..	Airframe spherical plain bearings – Self-lubricating high misalignment (inch dimensions), XCR plating on sphere	2.32 258	12CF..	For the cross-reference designation of this legacy product, see PHFJ/WAS.., EPHFJ/WAS..	
11E..H..	For the cross-reference designation of this legacy product, see HMEN..		12CM..	For the cross-reference designation of this legacy product, see PHMJ/WAS.., EPHMJ/WAS..	
11F..E.. for bore code 5	For the cross-reference designation of this legacy product, see WEN..		12CNF..	For the cross-reference designation of this legacy product, see PHEJ/NAS.., EPHFJ/NAS..	
11F..E.. for bore code 8 and ≥ 12 (except 2 ²⁾)	For the cross-reference designation of this legacy product, see NEN..		12CNM..	For the cross-reference designation of this legacy product, see PHMJ/NAS.., EPHMJ/NAS..	
11F..N.. for bore code ≥ 12	For the cross-reference designation of this legacy product, see LEN..		13AAF..	Airframe self-lubricating journal bearings – Flanged bearings, NSA 8148, inch dimensions, aluminium alloy, liner X1	4.8 418
11F..N.. for bore codes 6 and 10	For the cross-reference designation of this legacy product, see NEN..		13AAZ..	Airframe self-lubricating journal bearings – Plain bearings, NSA 8146, inch dimensions, aluminium alloy, liner X1	4.5 412
11F..W.. for bore code ≥ 6	For the cross-reference designation of this legacy product, see WEN..		13ASF..	Airframe self-lubricating journal bearings – Flanged bearings, NSA 8147, inch dimensions, corrosion-resistant-steel, liner X1	4.8 418
11F..W.. for bore codes 5 and 22	For the cross-reference designation of this legacy product, see NEN..				
11HH..	Airframe spherical plain bearings – Self-lubricating high misalignment (inch dimensions), XL coated sphere	2.32 258			
11HN..	For the cross-reference designation of this legacy product, see NAS..				
11HW..	For the cross-reference designation of this legacy product, see WAS..				
11KH..	Airframe spherical plain bearings – Self-lubricating high misalignment (inch dimensions), XLHT coated sphere	2.32 258			

¹⁾ Starting page of the product table.

Designation	Product	Product table		Designation	Product	Product table	
		No.	Page ¹⁾			No.	Page ¹⁾
13ASZ..	Airframe self-lubricating journal bearings – Plain bearings, NSA 8145, inch dimensions, corrosion-resistant-steel, liner X1	4.5	412	..AAK	Airframe self-lubricating journal bearings – Plain bearings, EN 2285, metric dimensions, aluminium alloy 2024, liner Fiberslip	4.1	404
13BAF..	Airframe self-lubricating journal bearings – Flanged bearings, AS 81934/2, inch dimensions, aluminium alloy	4.9	420	AG..	Airframe rolling bearings – Deep groove ball bearing double row (metric dimensions), not plated bearing steel	1.5	60
13BAZ..	Airframe self-lubricating journal bearings – Plain bearings, AS 81934/1, inch dimensions, aluminium alloy	4.6	414	AGN..	Airframe rolling bearings – Deep groove ball bearing double row, EN 3056 (metric dimensions), not plated bearing steel	1.6	62
13BSF..	Airframe self-lubricating journal bearings – Flanged bearings, AS 81934/2, inch dimensions, corrosion-resistant-steel	4.9	420	..AK	Airframe self-lubricating journal bearings – Plain bearings, metric dimensions, aluminium alloy 2618, liner Fiberslip	4.1	404
13BSZ..	Airframe self-lubricating journal bearings – Plain bearings, AS 81934/1, inch dimensions, corrosion-resistant-steel	4.6	414	AS 14101	For bearings according to this standard, see NAS.., ZNAS.., SZNAS.., ENAS.., ZENAS.., SZENAS..		
13C..AAF	Airframe self-lubricating journal bearings – Flanged bearings, EN 2286, metric dimensions, aluminium alloy 2024, liner X1	4.3	408	AS 14102	For bearings according to this standard, see WAS.., ZWAS.., SZWAS.., EWAS.., ZEWAS.., SZEWAS..		
13C..AAZ	Airframe self-lubricating journal bearings – Plain bearings, EN 2285, metric dimensions, aluminium alloy 2024, liner X1	4.1	404	AS 14103	For bearings according to this standard, see WAS.., ZWAS.., SZWAS.., EWAS.., ZEWAS.., SZEWAS..		
13C..AF	Airframe self-lubricating journal bearing – Flanged bearings, metric dimensions, aluminium alloy 2618, liner X1	4.3	408	AS 14104	For bearings according to this standard, see NAS.., ZNAS.., SZNAS.., ENAS.., ZENAS.., SZENAS..		
13C..AZ	Airframe self-lubricating journal bearing – Plain bearings, metric dimensions, aluminium alloy 2618, liner X1	4.1	404	AS 21151	For bearings according to this standard, see REP..M.., RA..M.., RAP..M.., REP..MR.., SREP..M.., SRA..M.., SRAP..M.., SREP..MR.., REP..ML.., RA..ML.., RAP..ML.., SREP..ML.., SRA..ML.., SRAP..ML..		
13C..SF	Airframe self-lubricating journal bearing – Flanged bearings, EN 2288, metric dimensions, corrosion-resistant-steel 17-4PH, liner X1	4.3	408	AS 21153	For bearings according to this standard, see REP.., REP..F.., SREP.., SREP..F.., REP..L.., REP..FL.., SREP..L.., SREP..FL..		
13C..SZ	Airframe self-lubricating journal bearing – Plain bearings, EN 2287, metric dimensions, corrosion-resistant-steel 17-4PH, liner X1	4.1	404	AS 21154	For bearings according to this standard, see ZWME.., ZWQME.., SZWQME..		
13D..AF	Airframe self-lubricating journal bearing – Flanged bearings, metric dimensions, aluminium alloy	4.4	410	AS 21155	For bearings according to this standard, see ZWME.., ZWQME.., SZWQME..		
13D..AZ	Airframe self-lubricating journal bearings – Plain bearings, metric dimensions, aluminium alloy	4.2	406	AS 21428	For bearings according to this standard, see MB5.., SMB5..		
13D..SF	Airframe self-lubricating journal bearings – Flanged bearings, metric dimensions, corrosion-resistant-steel	4.4	410	AS 27640	For bearings according to this standard, see KP.., KP..L, SKP.., SKP..L		
13D..SZ	Airframe self-lubricating journal bearings – Plain bearings, metric dimensions, aluminium alloy	4.2	406	AS 27641	For bearings according to this standard, see KP..A, SKP..A		
13EAF..	Airframe self-lubricating journal bearings – Flanged bearings, EN 4535-2, aluminium alloy	4.10	422	AS 27642	For bearings according to this standard, see KP..B, SKP..B		
13EAZ..	Airframe self-lubricating journal bearings – Plain bearings, EN 4534-2, inch dimensions, aluminium alloy	4.7	416	AS 27643	For bearings according to this standard, see KSP.., KSP..A, KSP..L, SKSP.., SKSP..A, SKSP..L		
13ESF..	Airframe self-lubricating journal bearings – Flanged bearings, EN 4537-2, corrosion-resistant-steel	4.10	422	AS 27644	For bearings according to this standard, see DPP.., SDPP..		
13ESZ..	Airframe self-lubricating journal bearings – Plain bearings, EN 4536-2, inch dimensions, corrosion-resistant-steel	4.7	416	AS 27646	For bearings according to this standard, see B5.., SB5..		
				AS 27646	For bearings according to this standard, see DSP.., SDSP..		
				AS 27647	For bearings according to this standard, see DW.., DW..K2, DW..K, SDW.., SDW..K2, SDW..K		
				AS 27648	For bearings according to this standard, see KP..BS, SKP..BS		
				AS 81820/1	For bearings according to this standard, see NAS..A.., ZNAS..A.., SZNAS..A.., ENAS..A.., ZENAS..A.., SZENAS..A..		

¹⁾ Starting page of the product table.

Designation	Product	Product table		Designation	Product	Product table	
		No.	Page ¹⁾			No.	Page ¹⁾
AS 81820/2	For bearings according to this standard, see WAS..A., ZWAS..A., SZWAS..A., EWAS..A., ZEWAS..A., SZEWAS..A.			CN..JESP..	Airframe rod ends – External thread rod end with integrated rolling bearing (inch dimensions), sealed bearing in bearing steel and rod end body in cadmium plated steel with UNJF profile thread	3.14	322
AS 81820/3	For bearings according to this standard, see WAS..A., ZWAS..A., SZWAS..A., EWAS..A., ZEWAS..A., SZEWAS..A.			CN..JSP..	Airframe rod ends – External thread rod end with integrated rolling bearing (inch dimensions), shielded bearing in bearing steel and rod end body in cadmium plated steel with UNJF profile thread	3.14	322
AS 81820/4	For bearings according to this standard, see NAS..A., ZNAS..A., SZNAS..A., ENAS..A., ZENAS..A., SZENAS..A.			CN..M	Airframe rod ends – External thread rod end with integrated rolling bearing (metric dimensions), shielded bearing in bearing steel and rod end body in cadmium plated steel	3.2	298
AS 81934/1	For bearings according to this standard, see 13BAZ.., 13BSZ..			CN..ME	Airframe rod ends – External thread rod end with integrated rolling bearing (metric dimensions), sealed bearing in bearing steel and rod end body in cadmium plated steel	3.2	298
AS 81934/2	For bearings according to this standard, see 13BAF.., 13BSF..			CN..MESP..	Airframe rod ends – External thread rod end with integrated rolling bearing (inch dimensions), sealed bearing in bearing steel and rod end body in cadmium plated steel with UNF profile thread	3.2	298
AS 81935/1	For bearings according to this standard, see MJ/WAS.., EMJ/WAS..			CN..MESP1	Airframe rod ends – External thread rod end with integrated rolling bearing (metric dimensions), sealed bearing in bearing steel and rod end body in cadmium plated steel	3.14	322
AS 81935/2	For bearings according to this standard, see FJ/WAS.., EFJ/WAS..			CN..MJ..	Airframe rod ends – External thread rod end with integrated rolling bearing, EN 3541 (metric dimensions), bearing in bearing steel and rod end body in cadmium plated steel	3.1	296
AS 81935/4	For bearings according to this standard, see MJ/NAS.., EMJ/NAS..			CN..MSP..	Airframe rod ends – External thread rod end with integrated rolling bearing (inch dimensions), shielded bearing in bearing steel and rod end body in cadmium plated steel with UNF profile thread	3.14	322
AS 81935/5	For bearings according to this standard, see FJ/NAS.., EFJ/NAS..			CN..MSP1	Airframe rod ends – External thread rod end with integrated rolling bearing (metric dimensions), shielded bearing in bearing steel and rod end body in cadmium plated steel	3.2	298
AS 81935/6	For bearings according to this standard, see EPHMJ/WAS.., PHMJ/WAS..			DPP..	Airframe rolling bearings – Deep groove ball bearing double row, AS 27644 (inch dimensions), cadmium plated bearing steel, standard tolerance	1.20	98
AS 81935/7	For bearings according to this standard, see PHFJ/WAS.., EPHFJ/WAS..			DSP..	Airframe rolling bearings – Self-aligning ball bearing double row, AS 27643 (inch dimensions), cadmium plated bearing steel, standard tolerance	1.26	114
AS 81935/8	For bearings according to this standard, see PHMJ/NAS.., EPHMJ/NAS..			DSRP..	Airframe rolling bearings – Spherical roller bearing single row (inch dimensions), cadmium plated bearing steel	1.27	116
AS 81935/9	For bearings according to this standard, see PHFJ/NAS.., EPHFJ/NAS..			DW..	Airframe rolling bearings – Deep groove ball bearing double row, AS 27647 (inch dimensions), cadmium plated bearing steel, standard tolerance	1.21	100
AS 81936/1	For bearings according to this standard, see QXMB..						
AS 81936/2	For bearings according to this standard, see QXMB..						
B5..	Airframe rolling bearings – Deep groove ball bearing single row, AS 27646 (inch dimensions), cadmium plated bearing steel, standard tolerance	1.18	92				
B55..	Airframe rolling bearings – Deep groove ball bearing double row (inch dimensions), cadmium plated bearing steel	1.19	96				
C..M	Airframe rod ends – External thread rod end with integrated rolling bearing (metric dimensions), shielded bearing in bearing steel and rod end body in cadmium plated steel	3.2	298				
C..ME	Airframe rod ends – External thread rod end with integrated rolling bearing (metric dimensions), sealed bearing in bearing steel and rod end body in cadmium plated steel	3.2	298				
C..MJ..	Airframe rod ends – External thread rod end with integrated rolling bearing, EN 3541 (metric dimensions), bearing in bearing steel and rod end body in cadmium plated steel	3.1	296				
CN..-..	Airframe rod ends – External thread rod end with integrated rolling bearing, EN 4156 (inch dimensions), shielded bearing in bearing steel and rod end body in cadmium plated steel	3.15	326				
CN..E..	Airframe rod ends – External thread rod end with integrated rolling bearing, EN 4156 (inch dimensions), sealed bearing in bearing steel and rod end body in cadmium plated steel	3.15	326				

¹⁾ Starting page of the product table.

Designation	Product	Product table No. Page ¹⁾	Designation	Product	Product table No. Page ¹⁾
DW..K	Airframe rolling bearings – Deep groove ball bearing double row, AS 27647 (inch dimensions), cadmium plated bearing steel, standard tolerance	1.21 100	EFJ/QMTC..R	Airframe rod ends – Internal thread inserted high misalignment metal-to-metal spherical plain bearing rod end (inch dimensions), cadmium plated steel rod end body, bronze beryllium inner ring and corrosion-resistant-steel outer ring with lubrication by the rod end body	3.35 380
DW..K2	Airframe rolling bearings – Deep groove ball bearing double row, AS 27647 (inch dimensions), cadmium plated bearing steel, standard tolerance	1.21 100	EFJ/QMTC..R	For the bearing used in this rod end, see QMT..	
EF..	Airframe rod ends – Internal thread integrated metal-to-metal spherical plain bearing rod end (metric dimensions), cadmium plated steel inner ring and cadmium plated steel rod end body	3.11 316	EFJ/QMT..R	Airframe rod ends – Internal thread inserted high misalignment metal-to-metal spherical plain bearing rod end (inch dimensions), cadmium plated steel rod end body, bronze beryllium inner ring and corrosion-resistant-steel outer ring without lubrication groove	3.35 380
EFJ/NAS..	Airframe rod ends – Internal thread inserted narrow self-lubricating spherical plain bearing rod end, AS 81935/5 (inch dimensions), PH13.8 inner ring and cadmium plated 4340 steel rod end body	3.27 358	EFJ/QMT..R	For the bearing used in this rod end, see QMT..	
EFJ/NAS..	For the bearing used in this rod end, see NAS..		EFJ/QMTS..R	Airframe rod ends – Internal thread inserted high misalignment metal-to-metal spherical plain bearing rod end (inch dimensions), cadmium plated steel rod end body, bronze beryllium inner ring and corrosion-resistant-steel outer ring with lubrication by the inner ring	3.35 380
EFJ/QML..	Airframe rod ends – Internal thread inserted wide metal-to-metal spherical plain bearing rod end (metric dimensions), cadmium plated steel rod end body, bronze beryllium inner ring and corrosion-resistant-steel outer ring	3.12 318	EFJ/QMTS..R	For the bearing used in this rod end, see QMT..	
EFJ/QML..	For the bearing used in this rod end, see QML..		EFJ/RL..	Airframe rod ends – Internal thread inserted wide self-lubricating spherical plain bearing rod end (metric dimensions), cadmium plated 30NCD16 steel rod end	3.6 306
EFJ/QMLC..R	Airframe rod ends – Internal thread inserted wide metal-to-metal spherical plain bearing rod end (inch dimensions), cadmium plated steel rod end body, bronze beryllium inner ring and corrosion-resistant-steel outer ring with lubrication by the rod end body	3.34 378	EFJ/RL..	For the bearing used in this rod end, see WEN..	
EFJ/QMLC..R	For the bearing used in this rod end, see QML..		EFJ/RL..R..	Airframe rod ends – Internal thread inserted wide self-lubricating spherical plain bearing rod end (inch dimensions), cadmium plated 30NCD16 steel rod end	3.30 370
EFJ/QML..R	Airframe rod ends – Internal thread inserted wide metal-to-metal spherical plain bearing rod end (inch dimensions), cadmium plated steel rod end body, bronze beryllium inner ring and corrosion-resistant-steel outer ring without lubrication groove	3.34 378	EFJ/RL..R..	For the bearing used in this rod end, see WAS..	
EFJ/QML..R	For the bearing used in this rod end, see QML..		EFJ/RT..	Airframe rod ends – Internal thread inserted high-misalignment self-lubricating spherical plain bearing rod end (metric dimensions), cadmium plated 30NCD16 steel rod end	3.7 308
EFJ/QMLC..R	For the bearing used in this rod end, see QML..		EFJ/RT..	For the bearing used in this rod end, see XRT..	
EFJ/QMLS..R	Airframe rod ends – Internal thread inserted wide metal-to-metal spherical plain bearing rod end (inch dimensions), cadmium plated steel rod end body, bronze beryllium inner ring and corrosion-resistant-steel outer ring with lubrication by the inner ring	3.34 378	EFJ/RT..R..	Airframe rod ends – Internal thread inserted high-misalignment self-lubricating spherical plain bearing rod end (inch dimensions), cadmium plated 30NCD16 steel rod end	3.31 372
EFJ/QMLS..R	For the bearing used in this rod end, see QML..		EFJ/RT..R..	For the bearing used in this rod end, see XRT..	
EFJ/QMT..	Airframe rod ends – Internal thread inserted high misalignment metal-to-metal spherical plain bearing rod end (metric dimensions), cadmium plated steel rod end body, bronze beryllium inner ring and corrosion-resistant-steel outer ring	3.13 320	EFJ/WAS..	Airframe rod ends – Internal thread inserted wide self-lubricating spherical plain bearing rod end, AS 81935/2 (inch dimensions), PH13.8 inner ring and cadmium plated 4340 steel rod end body	3.25 350
EFJ/QMT..	For the bearing used in this rod end, see QMT..		EFJ/WAS..	For the bearing used in this rod end, see WAS..	

¹⁾ Starting page of the product table.

Designation	Product	Product table No. Page ¹⁾	Designation	Product	Product table No. Page ¹⁾
EFJ/WML..	Airframe rod ends – Internal thread inserted wide metal-to-metal spherical plain bearing rod end (metric dimensions), cadmium plated steel rod end body, corrosion-resistant-steel inner ring and corrosion-resistant-steel outer ring	3.12 318	EFJ/WMTS..R	Airframe rod ends – Internal thread inserted high misalignment metal-to-metal spherical plain bearing rod end (inch dimensions), cadmium plated steel rod end body, corrosion-resistant-steel inner ring and corrosion-resistant-steel outer ring with lubrication by the inner ring	3.35 380
EFJ/WML..	For the bearing used in this rod end, see WML..		EFJ/WMTS..R	For the bearing used in this rod end, see WMT..	
EFJ/WMLC..R	Airframe rod ends – Internal thread inserted wide metal-to-metal spherical plain bearing rod end (inch dimensions), cadmium plated steel rod end body, corrosion-resistant-steel inner ring and corrosion-resistant-steel outer ring with lubrication by the rod end body	3.34 378	EFJ/WQML..	Airframe rod ends – Internal thread inserted wide metal-to-metal spherical plain bearing rod end (metric dimensions), cadmium plated steel rod end body, corrosion-resistant-steel inner ring and bronze aluminium outer ring	3.12 318
EFJ/WMLC..R	For the bearing used in this rod end, see WML..		EFJ/WQML..	For the bearing used in this rod end, see WQML..	
EFJ/WML..R	Airframe rod ends – Internal thread inserted wide metal-to-metal spherical plain bearing rod end (inch dimensions), cadmium plated steel rod end body, corrosion-resistant-steel inner ring and corrosion-resistant-steel outer ring without lubrication groove	3.34 378	EFJ/WQMLC..R	Airframe rod ends – Internal thread inserted wide metal-to-metal spherical plain bearing rod end (inch dimensions), cadmium plated steel rod end body, corrosion-resistant-steel inner ring and bronze aluminium outer ring with lubrication by the rod end body	3.34 378
EFJ/WML..R	For the bearing used in this rod end, see WML..		EFJ/WQMLC..R	For the bearing used in this rod end, see WQML..	
EFJ/WMLS..R	Airframe rod ends – Internal thread inserted wide metal-to-metal spherical plain bearing rod end (inch dimensions), cadmium plated steel rod end body, corrosion-resistant-steel inner ring and corrosion-resistant-steel outer ring with lubrication by the inner ring	3.34 378	EFJ/WQML..R	Airframe rod ends – Internal thread inserted wide metal-to-metal spherical plain bearing rod end (inch dimensions), cadmium plated steel rod end body, corrosion-resistant-steel inner ring and bronze aluminium outer ring without lubrication groove	3.34 378
EFJ/WMLS..R	For the bearing used in this rod end, see WML..		EFJ/WQML..R	For the bearing used in this rod end, see WQML..	
EFJ/WMT..	Airframe rod ends – Internal thread inserted high misalignment metal-to-metal spherical plain bearing rod end (metric dimensions), cadmium plated steel rod end body, corrosion-resistant-steel inner ring and corrosion-resistant-steel outer ring	3.13 320	EFJ/WQMLS..R	Airframe rod ends – Internal thread inserted wide metal-to-metal spherical plain bearing rod end (inch dimensions), cadmium plated steel rod end body, corrosion-resistant-steel inner ring and bronze aluminium outer ring with lubrication by the inner ring	3.34 378
EFJ/WMT..	For the bearing used in this rod end, see WMT..		EFJ/WQMLS..R	For the bearing used in this rod end, see WQML..	
EFJ/WMTC..R	Airframe rod ends – Internal thread inserted high misalignment metal-to-metal spherical plain bearing rod end (inch dimensions), cadmium plated steel rod end body, corrosion-resistant-steel inner ring and corrosion-resistant-steel outer ring with lubrication by the rod end body	3.35 380	EFJ/WQMT..	Airframe rod ends – Internal thread inserted high misalignment metal-to-metal spherical plain bearing rod end (metric dimensions), cadmium plated steel rod end body, corrosion-resistant-steel inner ring and bronze aluminium outer ring	3.13 320
EFJ/WMTC..R	For the bearing used in this rod end, see WMT..		EFJ/WQMT..	For the bearing used in this rod end, see WQMT..	
EFJ/WMT..R	Airframe rod ends – Internal thread inserted high misalignment metal-to-metal spherical plain bearing rod end (inch dimensions), cadmium plated steel rod end body, corrosion-resistant-steel inner ring and corrosion-resistant-steel outer ring without lubrication groove	3.35 380	EFJ/WQMTC..R	Airframe rod ends – Internal thread inserted high misalignment metal-to-metal spherical plain bearing rod end (inch dimensions), cadmium plated steel rod end body, corrosion-resistant-steel inner ring and bronze aluminium outer ring with lubrication by the rod end body	3.35 380
EFJ/WMT..R	For the bearing used in this rod end, see WMT..		EFJ/WQMTC..R	For the bearing used in this rod end, see WQMT..	

¹⁾ Starting page of the product table.

Designation	Product	Product table No.	Page ¹⁾	Designation	Product	Product table No.	Page ¹⁾
EFJ/WQMT..R	Airframe rod ends – Internal thread inserted high misalignment metal-to-metal spherical plain bearing rod end (inch dimensions), cadmium plated steel rod end body, corrosion-resistant-steel inner ring and bronze aluminium outer ring without lubrication groove	3.35	380	EMJ/QMLS..R	Airframe rod ends – External thread inserted wide metal-to-metal spherical plain bearing rod end (inch dimensions), cadmium plated steel rod end body, bronze beryllium inner ring and corrosion-resistant-steel outer ring with lubrication by the inner ring	3.32	374
EFJ/WQMT..R	For the bearing used in this rod end, see WQMT..			EMJ/QMLS..R	For the bearing used in this rod end, see QML..		
EFJ/WQMTS..R	Airframe rod ends – Internal thread inserted high misalignment metal-to-metal spherical plain bearing rod end (inch dimensions), cadmium plated steel rod end body, corrosion-resistant-steel inner ring and bronze aluminium outer ring with lubrication by the inner ring	3.35	380	EMJ/QMT..	Airframe rod ends – External thread inserted high misalignment metal-to-metal spherical plain bearing rod end (metric dimensions), cadmium plated steel rod end body, bronze beryllium inner ring and corrosion-resistant-steel outer ring	3.10	314
EFJ/WQMTS..R	For the bearing used in this rod end, see WQMT..			EMJ/QMT..	For the bearing used in this rod end, see QMT..		
EM..	Airframe rod ends – External thread integrated metal-to-metal spherical plain bearing rod end (metric dimensions), cadmium plated steel inner ring and cadmium plated steel rod end body	3.8	310	EMJ/QMTC..R	Airframe rod ends – External thread inserted high misalignment metal-to-metal spherical plain bearing rod end (inch dimensions), cadmium plated steel rod end body, bronze beryllium inner ring and corrosion-resistant-steel outer ring with lubrication by the rod end body	3.33	376
EMA..	Airframe rod ends – External thread inserted self-lubricating spherical plain bearing rod end, EN 2498 (metric dimensions), cadmium plated 30NCD16 steel rod end	3.3	300	EMJ/QMTC..R	For the bearing used in this rod end, see QMT..		
EMA..	For the bearing used in this rod end, see HMEN..R..			EMJ/QMT..R	Airframe rod ends – External thread inserted high misalignment metal-to-metal spherical plain bearing rod end (inch dimensions), cadmium plated steel rod end body, bronze beryllium inner ring and corrosion-resistant-steel outer ring without lubrication groove	3.33	376
EMJ/NAS..	Airframe rod ends – External thread inserted narrow self-lubricating spherical plain bearing rod end, AS 81935/4 (inch dimensions), PH13.8 inner ring and cadmium plated 4340 steel rod end body	3.20	340	EMJ/QMT..R	For the bearing used in this rod end, see QMT..		
EMJ/NAS..	For the bearing used in this rod end, see ENAS..			EMJ/QMTS..R	Airframe rod ends – External thread inserted high misalignment metal-to-metal spherical plain bearing rod end (inch dimensions), cadmium plated steel rod end body, bronze beryllium inner ring and corrosion-resistant-steel outer ring with lubrication by the inner ring	3.33	376
EMJ/QML..	Airframe rod ends – External thread inserted wide metal-to-metal spherical plain bearing rod end (metric dimensions), cadmium plated steel rod end body, bronze beryllium inner ring and corrosion-resistant-steel outer ring	3.9	312	EMJ/QMTS..R	For the bearing used in this rod end, see QMT..		
EMJ/QML..	For the bearing used in this rod end, see QML..			EMJ/RL..	Airframe rod ends – External thread inserted wide self-lubricating spherical plain bearing rod end (metric dimensions), cadmium plated 30NCD16 steel rod end	3.4	302
EMJ/QMLC..R	Airframe rod ends – External thread inserted wide metal-to-metal spherical plain bearing rod end (inch dimensions), cadmium plated steel rod end body, bronze beryllium inner ring and corrosion-resistant-steel outer ring with lubrication by the rod end body	3.32	374	EMJ/RL..	For the bearing used in this rod end, see WEN..		
EMJ/QMLC..R	For the bearing used in this rod end, see QML..			EMJ/RL..R..	Airframe rod ends – External thread inserted wide self-lubricating spherical plain bearing rod end (inch dimensions), cadmium plated 30NCD16 steel rod end	3.23	346
EMJ/QML..R	Airframe rod ends – External thread inserted wide metal-to-metal spherical plain bearing rod end (inch dimensions), cadmium plated steel rod end body, bronze beryllium inner ring and corrosion-resistant-steel outer ring without lubrication groove	3.32	374	EMJ/RL..R..	For the bearing used in this rod end, see WAS..		
EMJ/QML..R	For the bearing used in this rod end, see QML..			EMJ/RT..	Airframe rod ends – External thread inserted high-misalignment self-lubricating spherical plain bearing rod end (metric dimensions), cadmium plated 30NCD16 steel rod end	3.5	304
				EMJ/RT..	For the bearing used in this rod end, see XRT..		

¹⁾ Starting page of the product table.

Designation	Product	Product table		Designation	Product	Product table	
		No.	Page ¹⁾			No.	Page ¹⁾
EMJ/RT..R..	Airframe rod ends – External thread inserted high-misalignment self-lubricating spherical plain bearing rod end (inch dimensions), cadmium plated 30NCD16 steel rod end	3.24	348	EMJ/WMTC..R	Airframe rod ends – External thread inserted high misalignment metal-to-metal spherical plain bearing rod end (inch dimensions), cadmium plated steel rod end body, corrosion-resistant-steel inner ring and corrosion-resistant-steel outer ring with lubrication by the rod end body	3.33	376
EMJ/RT..R..	For the bearing used in this rod end, see XRT..			EMJ/WMTC..R	For the bearing used in this rod end, see WMT..		
EMJ/WAS..	Airframe rod ends – External thread inserted wide self-lubricating spherical plain bearing rod end, AS 81935/1 (inch dimensions), PH13.8 inner ring and cadmium plated 4340 steel rod end body	3.18	336	EMJ/WMT..R	Airframe rod ends – External thread inserted high misalignment metal-to-metal spherical plain bearing rod end (inch dimensions), cadmium plated steel rod end body, corrosion-resistant-steel inner ring and corrosion-resistant-steel outer ring without lubrication groove	3.33	376
EMJ/WAS..	For the bearing used in this rod end, see EWAS..			EMJ/WMT..R	For the bearing used in this rod end, see WMT..		
EMJ/WML..	Airframe rod ends – External thread inserted wide metal-to-metal spherical plain bearing rod end (metric dimensions), cadmium plated steel rod end body, corrosion-resistant-steel inner ring and corrosion-resistant-steel outer ring	3.9	312	EMJ/WMTS..R	Airframe rod ends – External thread inserted high misalignment metal-to-metal spherical plain bearing rod end (inch dimensions), cadmium plated steel rod end body, corrosion-resistant-steel inner ring and corrosion-resistant-steel outer ring with lubrication by the inner ring	3.33	376
EMJ/WML..	For the bearing used in this rod end, see WML..			EMJ/WMTS..R	For the bearing used in this rod end, see WMT..		
EMJ/WMLC..R	Airframe rod ends – External thread inserted wide metal-to-metal spherical plain bearing rod end (inch dimensions), cadmium plated steel rod end body, corrosion-resistant-steel inner ring and corrosion-resistant-steel outer ring with lubrication by the rod end body	3.32	374	EMJ/WQML..	Airframe rod ends – External thread inserted wide metal-to-metal spherical plain bearing rod end (metric dimensions), cadmium plated steel rod end body, corrosion-resistant-steel inner ring and bronze aluminium outer ring	3.9	312
EMJ/WMLC..R	For the bearing used in this rod end, see WML..			EMJ/WQML..	For the bearing used in this rod end, see WQML..		
EMJ/WML..R	Airframe rod ends – External thread inserted wide metal-to-metal spherical plain bearing rod end (inch dimensions), cadmium plated steel rod end body, corrosion-resistant-steel inner ring and corrosion-resistant-steel outer ring without lubrication groove	3.32	374	EMJ/WQMLC..R	Airframe rod ends – External thread inserted wide metal-to-metal spherical plain bearing rod end (inch dimensions), cadmium plated steel rod end body, corrosion-resistant-steel inner ring and bronze aluminium outer ring with lubrication by the rod end body	3.32	374
EMJ/WML..R	For the bearing used in this rod end, see WML..			EMJ/WQML..R	For the bearing used in this rod end, see WQML..		
EMJ/WMLS..R	Airframe rod ends – External thread inserted wide metal-to-metal spherical plain bearing rod end (inch dimensions), cadmium plated steel rod end body, corrosion-resistant-steel inner ring and corrosion-resistant-steel outer ring with lubrication by the inner ring	3.32	374	EMJ/WQML..R	Airframe rod ends – External thread inserted wide metal-to-metal spherical plain bearing rod end (inch dimensions), cadmium plated steel rod end body, corrosion-resistant-steel inner ring and bronze aluminium outer ring without lubrication groove	3.32	374
EMJ/WMLS..R	For the bearing used in this rod end, see WML..			EMJ/WQMLS..R	Airframe rod ends – External thread inserted wide metal-to-metal spherical plain bearing rod end (inch dimensions), cadmium plated steel rod end body, corrosion-resistant-steel inner ring and bronze aluminium outer ring with lubrication by the inner ring	3.32	374
EMJ/WMT..	Airframe rod ends – External thread inserted high misalignment metal-to-metal spherical plain bearing rod end (metric dimensions), cadmium plated steel rod end body, corrosion-resistant-steel inner ring and corrosion-resistant-steel outer ring	3.10	314	EMJ/WQMLS..R	For the bearing used in this rod end, see WQML..		
EMJ/WMT..	For the bearing used in this rod end, see WMT..						

¹⁾ Starting page of the product table.

Designation	Product	Product table No. Page ¹⁾	Designation	Product	Product table No. Page ¹⁾
EMJ/WQMT..	Airframe rod ends – External thread inserted high misalignment metal-to-metal spherical plain bearing rod end (metric dimensions), cadmium plated steel rod end body, corrosion-resistant-steel inner ring and bronze aluminium outer ring	3.10 314	EN 3054	For bearings according to this standard, see ZK., ZKN., ZK.F, ZKN..F	
EMJ/WQMT..	For the bearing used in this rod end, see WQMT..		EN 3055	For bearings according to this standard, see WK., WKN., WK.F, WKN..F	
EMJ/WQMT..R	Airframe rod ends – External thread inserted high misalignment metal-to-metal spherical plain bearing rod end (inch dimensions), cadmium plated steel rod end body, corrosion-resistant-steel inner ring and bronze aluminium outer ring with lubrication by the rod end body	3.33 376	EN 3056	For bearings according to this standard, see AGN..	
EMJ/WQMT..R	For the bearing used in this rod end, see WQMT..		EN 3057	For bearings according to this standard, see ZAGN..	
EMJ/WQMT..R	Airframe rod ends – External thread inserted high misalignment metal-to-metal spherical plain bearing rod end (inch dimensions), cadmium plated steel rod end body, corrosion-resistant-steel inner ring and bronze aluminium outer ring without lubrication groove	3.33 376	EN 3058	For bearings according to this standard, see WAGN..	
EMJ/WQMT..R	For the bearing used in this rod end, see WQMT..		EN 3059	For bearings according to this standard, see TRCE., STRCE..	
EMJ/WQMT..R	Airframe rod ends – External thread inserted high misalignment metal-to-metal spherical plain bearing rod end (inch dimensions), cadmium plated steel rod end body, corrosion-resistant-steel inner ring and bronze aluminium outer ring with lubrication by the inner ring	3.33 376	EN 3060	For bearings according to this standard, see ZTRCE., SZTRCE..	
EMJ/WQMT..R	For the bearing used in this rod end, see WQMT..		EN 3061	For bearings according to this standard, see XTRCE..	
EMJ/WQMTS..R	Airframe rod ends – External thread inserted high misalignment metal-to-metal spherical plain bearing rod end (inch dimensions), cadmium plated steel rod end body, corrosion-resistant-steel inner ring and bronze aluminium outer ring with lubrication by the inner ring	3.33 376	EN 3281	For bearings according to this standard, see TA..	
EMJ/WQMTS..R	For the bearing used in this rod end, see WQMT..		EN 3282	For bearings according to this standard, see ZTA..	
EN 2285	For bearings according to this standard, see 13C..AAZ, ..AAK		EN 3283	For bearings according to this standard, see WATA..	
EN 2286	For bearings according to this standard, see 13C..AAF, ..FAAK		EN 3284	For bearings according to this standard, see JNA..	
EN 2287	For bearings according to this standard, see 13C..SZ, ..SK		EN 3285	For bearings according to this standard, see ZJNA..	
EN 2288	For bearings according to this standard, see 13C..SF		EN 3286	For bearings according to this standard, see WJNA..	
EN 2335	For bearings according to this standard, see WMA..		EN 3287	For bearings according to this standard, see KN..	
EN 2336	For bearings according to this standard, see GE..		EN 3288	For bearings according to this standard, see ZKN..	
EN 2498	For bearings according to this standard, see EMA..		EN 3289	For bearings according to this standard, see WKN..	
EN 2584	For bearings according to this standard, see NEN..		EN 3290	For bearings according to this standard, see KNA..F	
EN 2585	For bearings according to this standard, see WEN..		EN 3291	For bearings according to this standard, see ZKNA..F	
EN 2588	For bearings according to this standard, see WGE..		EN 3292	For bearings according to this standard, see WKNA..F	
EN 2618	For bearings according to this standard, see 13C..AZ, ..AK, 13C..AF, ..FSK		EN 3541	For bearings according to this standard, see C..MJ., C..MJ..	
EN 3045	For bearings according to this standard, see JNA..		EN 4034	For bearings according to this standard, see WKNRCE..	
EN 3046	For bearings according to this standard, see ZJNA..		EN 4036	For bearings according to this standard, see XC..MJ., XC..MJ..	
EN 3047	For bearings according to this standard, see WJNA..		EN 4037	For bearings according to this standard, see LEN..	
EN 3048	For bearings according to this standard, see LEN..		EN 4038	For bearings according to this standard, see NEN..	
EN 3053	For bearings according to this standard, see K., KN., K.F, KN..F		EN 4039	For bearings according to this standard, see WEN..	
			EN 4040	For bearings according to this standard, see HMEN..	
			EN 4041	For bearings according to this standard, see TRCEI., XTRCEI..	
			EN 4156	For bearings according to this standard, see CN.-., CN..E..	
			EN 4157	For bearings according to this standard, see WCN.-., WCN..E..	
			EN 4198	For bearings according to this standard, see XEMA..	
			EN 4265	For bearings according to this standard, see ENL..	
			EN 4266	For bearings according to this standard, see ZENL..	
			EN 4534-2	For bearings according to this standard, see 13EAF..	
			EN 4535-2	For bearings according to this standard, see 13EAF..	
			EN 4536-2	For bearings according to this standard, see 13ESZ..	

¹⁾ Starting page of the product table.

Designation	Product	Product table		Designation	Product	Product table	
		No.	Page ¹⁾			No.	Page ¹⁾
EN 4537-2	For bearings according to this standard, see 13ESF..			FJ/NAS..	Airframe rod ends – Internal thread inserted narrow self-lubricating spherical plain bearing rod end, AS 81935/5 (inch dimensions), 440C inner ring and cadmium plated 4340 steel rod end body	3.27	358
EN 6046	For bearings according to this standard, see ENE.., ZENE..			FJ/NAS..	For the bearing used in this rod end, see NAS..		
ENAS..	Airframe spherical plain bearings – Self-lubricating narrow, AS 14101, AS 14104 (inch dimensions), PH13.8 inner ring and not plated outer ring	2.26	236	FJ/WAS..	Airframe rod ends – Internal thread inserted wide self-lubricating spherical plain bearing rod end, AS 81935/2 (inch dimensions), 440C inner ring and cadmium plated 4340 steel rod end body	3.25	350
ENAS..	For rod ends using this bearing, see EMJ/NAS.., SEMJ/NAS.., EPHMJ/NAS.., EFJ/NAS.., SEFJ/NAS.., PHFJ/NAS..			FJ/WAS..	For the bearing used in this rod end, see WAS..		
ENAS..A..	Airframe spherical plain bearings – Self-lubricating narrow, AS 81820/1, AS 81820/4 (inch dimensions), PH13.8 inner ring and not plated outer ring	2.27	240	..FSK	Airframe self-lubricating journal bearings – Flanged bearings, EN 2288, metric dimensions, corrosion-resistant-steel 17-4PH, liner Fiberslip	4.3	408
ENE..	Airframe spherical plain bearings – Metal-to-metal swaged narrow, EN 6046 (inch dimensions), not plated	2.12	190	..FSK	Airframe self-lubricating journal bearings – Flanged bearings, metric dimensions, aluminium alloy 2618, liner Fiberslip	4.3	408
ENL..	Airframe spherical plain bearings – Metal-to-metal swaged wide, EN 4265 (inch dimensions), not plated	2.14	198	GE..	Airframe spherical plain bearings – Metal-to-metal loader slot, EN 2336 (metric dimensions), bearing steel inner ring and outer ring not plated	2.1	156
EPHFJ/NAS..	Airframe rod ends – Internal thread inserted narrow self-lubricating spherical plain bearing rod end, AS 81935/9 (inch dimensions), PH13.8 inner ring and passivated PH13.8 rod end body	3.28	362	GL..	Airframe spherical plain bearings – Metal-to-metal loader slot normal (metric dimensions), bearing steel inner ring and outer ring not plated	2.2	160
EPHFJ/NAS..	For the bearing used in this rod end, see NAS..			GLD..	Airframe spherical plain bearings – Metal-to-metal loader slot normal (metric dimensions), bearing steel inner ring and outer ring not plated	2.2	160
EPHFJ/WAS..	Airframe rod ends – Internal thread inserted wide self-lubricating spherical plain bearing rod end, AS 81935/7 (inch dimensions), PH13.8 inner ring and passivated PH13.8 rod end body	3.26	354	GLS..	Airframe spherical plain bearings – Metal-to-metal loader slot normal (metric dimensions), bearing steel inner ring and outer ring not plated	2.2	160
EPHFJ/WAS..	For the bearing used in this rod end, see WAS..			GLS..MRTG	Airframe spherical plain bearings – Metal-to-metal loader slot normal reinforced (metric dimensions), bearing steel inner ring and outer ring not plated with molybdenum disulfide	2.3	164
EPHMJ/NAS..	Airframe rod ends – External thread inserted narrow self-lubricating spherical plain bearing rod end, AS 81935/8 (inch dimensions), PH13.8 inner ring and passivated PH13.8 rod end body	3.21	342	GLS..RTG	Airframe spherical plain bearings – Metal-to-metal loader slot normal reinforced (metric dimensions), bearing steel inner ring and outer ring not plated	2.3	164
EPHMJ/NAS..	For the bearing used in this rod end, see ENAS..			GLS..TAG	Airframe spherical plain bearings – Metal-to-metal loader slot normal (metric dimensions), bearing steel inner ring and outer ring not plated	2.2	160
EPHMJ/WAS..	Airframe rod ends – External thread inserted wide self-lubricating spherical plain bearing rod end, AS 81935/6 (inch dimensions), PH13.8 inner ring and passivated PH13.8 rod end body	3.19	338	GT..	Airframe spherical plain bearings – Metal-to-metal loader slot wide (metric dimensions), bearing steel inner ring and outer ring not plated	2.4	166
EPHMJ/WAS..	For the bearing used in this rod end, see EWAS..			GT..	Airframe spherical plain bearings – Metal-to-metal loader slot wide (inch dimensions), bearing steel inner ring and outer ring not plated	2.10	184
EWAS..	Airframe spherical plain bearings – Self-lubricating narrow, AS 14102, AS 14103 (inch dimensions), PH13.8 inner ring and not plated outer ring	2.29	248	HMEN..	Airframe spherical plain bearings – Self-lubricating high-misalignment, EN 4040 (metric dimensions), not plated	2.21	224
EWAS..A..	Airframe spherical plain bearings – Self-lubricating narrow, AS 81820/2, AS 81820/3 (inch dimensions), PH13.8 inner ring and not plated outer ring	2.30	252	HMEN..	For rod ends using this bearing, see EMA.., SEMA.., XEMA.., TEMA..		125
..FAAK	Airframe self-lubricating journal bearings – Flanged bearings, EN 2286, metric dimensions, aluminium alloy 2024, liner Fiberslip	4.3	408				

¹⁾ Starting page of the product table.

Designation	Product	Product table		Designation	Product	Product table	
		No.	Page ¹⁾			No.	Page ¹⁾
JN..	Airframe rolling bearings – Deep groove ball bearing single row (metric dimensions), not plated bearing steel	1.1	52	KP..B	Airframe rolling bearings – Deep groove ball bearing single row, AS 27642 (inch dimensions), cadmium plated bearing steel, standard tolerance	1.16	84
JNA..	Airframe rolling bearings – Deep groove ball bearing single row, EN 3284, EN 3045 (metric dimensions), not plated bearing steel	1.2	54	KP..BS	Airframe rolling bearings – Deep groove ball bearing with self-aligning ring single row, AS 27648 (inch dimensions), cadmium plated bearing steel, standard tolerance	1.22	102
K..	Airframe rolling bearings – Spherical roller bearing single row, EN 3053 (metric dimensions), not plated bearing steel	1.11	72	KP..L	Airframe rolling bearings – Deep groove ball bearing single row, AS 27640 (inch dimensions), cadmium plated bearing steel, standard tolerance	1.14	78
KAF..P	Airframe self-lubricating journal bearings – Flanged bearings, NSA 8148, inch dimensions, aluminium alloy, liner Fiberslip	4.8	418	KP..LPSP..	Airframe rolling bearings – Deep groove ball bearing single row (inch dimensions), cadmium plated bearing steel, shielded	1.17	90
KA..P	Airframe self-lubricating journal bearings – Plain bearings, NSA 8146, inch dimensions, aluminium alloy, liner Fiberslip	4.5	412	KP..LSP..	Airframe rolling bearings – Deep groove ball bearing single row (inch dimensions), cadmium plated bearing steel, sealed	1.17	90
K..D	Airframe rolling bearings – Spherical roller bearing double row (metric dimensions), not plated bearing steel	1.13	76	KP..PSP..	Airframe rolling bearings – Deep groove ball bearing single row (inch dimensions), cadmium plated bearing steel, shielded	1.17	90
K..F	Airframe rolling bearings – Spherical roller bearing single row, EN 3053 (metric dimensions), not plated bearing steel	1.11	72	KP..SP..	Airframe rolling bearings – Deep groove ball bearing single row (inch dimensions), cadmium plated bearing steel, sealed	1.17	90
KN..	Airframe rolling bearings – Self-aligning ball bearing double row, EN 3287 (metric dimensions), not plated bearing steel	1.9	68	KSF..P	Airframe self-lubricating journal bearings – Flanged bearings, NSA 8147, inch dimensions, corrosion-resistant-steel, liner Fiberslip	4.8	418
KN..	Airframe rolling bearings – Self-aligning ball bearing double row (inch dimensions), not plated bearing steel	1.25	112	KS..P	Airframe self-lubricating journal bearings – Plain bearings, NSA 8145, inch dimensions, corrosion-resistant-steel, liner Fiberslip	4.5	412
KN..	Airframe rolling bearings – Spherical roller bearing single row, EN 3053 (metric dimensions), not plated bearing steel	1.11	72	KSP..	Airframe rolling bearings – Self-aligning ball bearing single row, AS 27645 (inch dimensions), cadmium plated bearing steel, standard tolerance	1.23	106
KNA..F	Airframe rolling bearings – Spherical roller bearing single row, EN 3290 (metric dimensions), not plated bearing steel	1.12	74	KSP..A	Airframe rolling bearings – Self-aligning ball bearing single row, AS 27645 (inch dimensions), cadmium plated bearing steel, standard tolerance	1.23	106
KN..F	Airframe rolling bearings – Spherical roller bearing single row, EN 3053 (metric dimensions), not plated bearing steel	1.11	72	KSP..APSP..	Airframe rolling bearings – Self-aligning ball bearing single row (inch dimensions), cadmium plated bearing steel, shielded	1.24	110
KNRCE..	Airframe rolling bearings – Self-aligning ball bearing double row (metric dimensions), not plated bearing steel	1.10	70	KSP..ASP..	Airframe rolling bearings – Self-aligning ball bearing single row (inch dimensions), cadmium plated bearing steel, sealed	1.24	110
KP..	Airframe rolling bearings – Deep groove ball bearing single row, AS 27640 (inch dimensions), cadmium plated bearing steel, standard tolerance	1.14	78	KSP..L	Airframe rolling bearings – Self-aligning ball bearing single row, AS 27645 (inch dimensions), cadmium plated bearing steel, standard tolerance	1.24	110
KP..A	Airframe rolling bearings – Deep groove ball bearing single row, AS 27641 (inch dimensions), cadmium plated bearing steel, standard tolerance	1.15	80	KSP..PSP..	Airframe rolling bearings – Self-aligning ball bearing single row (inch dimensions), cadmium plated bearing steel, shielded	1.24	110
KP..APSP..	Airframe rolling bearings – Deep groove ball bearing single row (inch dimensions), cadmium plated bearing steel, shielded	1.17	90	KSP..SP..	Airframe rolling bearings – Self-aligning ball bearing single row (inch dimensions), cadmium plated bearing steel, sealed	1.24	110
KP..ASP..	Airframe rolling bearings – Deep groove ball bearing single row (inch dimensions), cadmium plated bearing steel, sealed	1.17	90				

¹⁾ Starting page of the product table.

Designation	Product	Product table No. Page ¹⁾	Designation	Product	Product table No. Page ¹⁾
LEN..	Airframe spherical plain bearings – Self-lubricating light, EN 3048, EN 4037 (metric dimensions), not plated	2.18 214	MKP..L	Airframe rolling bearings – Deep groove ball bearing single row (inch dimensions), cadmium plated bearing steel, reduced tolerance and SKF super precision	1.14 78
MB5..	Airframe rolling bearings – Deep groove ball bearing single row, AS 21428 (inch dimensions), cadmium plated bearing steel, reduced clearance and precision	1.18 92	MKSP..	Airframe rolling bearings – Self-aligning ball bearing single row (inch dimensions), cadmium plated bearing steel, reduced tolerance and SKF super precision	1.23 106
MDPP..	Airframe rolling bearings – Deep groove ball bearing double row (inch dimensions), cadmium plated bearing steel, reduced tolerance and SKF super precision	1.20 98	MKSP..A	Airframe rolling bearings – Self-aligning ball bearing single row (inch dimensions), cadmium plated bearing steel, reduced tolerance and SKF super precision	1.23 106
MDSP..	Airframe rolling bearings – Self-aligning ball bearing double row (inch dimensions), cadmium plated bearing steel, reduced tolerance and SKF super precision	1.26 114	MKSP..L	Airframe rolling bearings – Self-aligning ball bearing single row (inch dimensions), cadmium plated bearing steel, reduced tolerance and SKF super precision	1.23 106
MDW..	Airframe rolling bearings – Deep groove ball bearing double row (inch dimensions), cadmium plated bearing steel, reduced tolerance and SKF super precision	1.21 100	NAS..	Airframe spherical plain bearings – Self-lubricating narrow, AS 14101, AS 14104 (inch dimensions), 440C inner ring and not plated outer ring	2.26 236
MDW..K	Airframe rolling bearings – Deep groove ball bearing double row (inch dimensions), cadmium plated bearing steel, reduced tolerance and SKF super precision	1.21 100	NAS..	For rod ends using this bearing, see MJ/NAS.., SMJ/NAS.., PHMJ/NAS.., FJ/NAS.., SFJ/NAS.., PHFJ/NAS..	
MDW..K2	Airframe rolling bearings – Deep groove ball bearing double row (inch dimensions), cadmium plated bearing steel, reduced tolerance and SKF super precision	1.21 100	NAS..A..	Airframe spherical plain bearings – Self-lubricating narrow, AS 81820/1, AS 81820/4 (inch dimensions), 440C inner ring and not plated outer ring	2.27 240
MJ/NAS..	Airframe rod ends – External thread inserted narrow self-lubricating spherical plain bearing rod end, AS 81935/4 (inch dimensions), 440C inner ring and cadmium plated 4340 steel rod end body	3.20 340	NEN..	Airframe spherical plain bearings – Self-lubricating narrow, EN 2584, EN 4038 (metric dimensions), not plated	2.19 216
MJ/NAS..	For the bearing used in this rod end, see NAS..		NSA 8134	For bearings according to this standard, see SN..	
MJ/WAS..	Airframe rod ends – External thread inserted wide self-lubricating spherical plain bearing rod end, AS 81935/1 (inch dimensions), 440C inner ring and cadmium plated 4340 steel rod end body	3.18 336	NSA 8135	For bearings according to this standard, see SW..	
MJ/WAS..	For the bearing used in this rod end, see WAS..		NSA 8136	For bearings according to this standard, see SN..	
MKP..	Airframe rolling bearings – Deep groove ball bearing single row (inch dimensions), cadmium plated bearing steel, reduced tolerance and SKF super precision	1.14 78	NSA 8137	For bearings according to this standard, see SW..	
MKP..A	Airframe rolling bearings – Deep groove ball bearing single row (inch dimensions), cadmium plated bearing steel, reduced tolerance and SKF super precision	1.15 80	NSA 8143	For bearings according to this standard, see R..M..	
MKP..B	Airframe rolling bearings – Deep groove ball bearing single row (inch dimensions), cadmium plated bearing steel, reduced tolerance and SKF super precision	1.16 84	NSA 8145	For bearings according to this standard, see 13ASZ.., KS..P	
MKP..BS	Airframe rolling bearings – Deep groove ball bearing with self-aligning ring single row (inch dimensions), cadmium plated bearing steel, reduced tolerance and SKF super precision	1.22 102	NSA 8146	For bearings according to this standard, see 13AAZ.., KA..P	
			NSA 8147	For bearings according to this standard, see 13ASF.., KSF..P	
			NSA 8148	For bearings according to this standard, see 13AAF.., KAF..P	
			NSA 8149	For bearings according to this standard, see R..F..	
			PHFJ/NAS..	Airframe rod ends – Internal thread inserted narrow self-lubricating spherical plain bearing rod end, AS 81935/9 (inch dimensions), 440C inner ring and passivated PH13.8 rod end body	3.28 362
			PHFJ/NAS..	For the bearing used in this rod end, see NAS..	
			PHFJ/WAS..	Airframe rod ends – Internal thread inserted wide self-lubricating spherical plain bearing rod end, AS 81935/7 (inch dimensions), 440C inner ring and passivated PH13.8 rod end body	3.26 354
			PHFJ/WAS..	For the bearing used in this rod end, see WAS..	

¹⁾ Starting page of the product table.

Designation	Product	Product table		Designation	Product	Product table	
		No.	Page ¹⁾			No.	Page ¹⁾
PHMJ/NAS..	Airframe rod ends – External thread inserted narrow self-lubricating spherical plain bearing rod end, AS 81935/8 (inch dimensions), 440C inner ring and passivated PH13.8 rod end body	3.21	342	QGLS..MRTG	Airframe spherical plain bearings – Metal-to-metal loader slot normal reinforced , (metric dimensions), bronze beryllium inner ring and corrosion-resistant-steel outer ring not plated with molybdenum disulfide	2.3	164
PHMJ/NAS..	For the bearing used in this rod end, see NAS..			QGLS..RTG	Airframe spherical plain bearings – Metal-to-metal loader slot normal reinforced , (metric dimensions), bronze beryllium inner ring and corrosion-resistant-steel outer ring not plated	2.3	164
PHMJ/WAS..	Airframe rod ends – External thread inserted wide self-lubricating spherical plain bearing rod end, AS 81935/6 (inch dimensions), 440C inner ring and passivated PH13.8 rod end body	3.19	338	QGLS..TAG	Airframe spherical plain bearings – Metal-to-metal loader slot normal, (metric dimensions), bronze beryllium inner ring and corrosion-resistant-steel outer ring not plated	2.2	160
PHMJ/WAS..	For the bearing used in this rod end, see WAS..			QGT..	Airframe spherical plain bearings – Metal-to-metal loader slot wide , (metric dimensions), bronze beryllium inner ring and corrosion-resistant-steel outer ring not plated	2.4	166
PHUFJ/XRE..	For the cross-reference designation of this legacy product, see PHFJ/NAS..., EPHFJ/NAS..			QGT..	Airframe spherical plain bearings – Metal-to-metal loader slot wide, (inch dimensions), bronze beryllium inner ring and corrosion-resistant-steel outer ring not plated	2.10	184
PHUFJ/XRL..	For the cross-reference designation of this legacy product, see PHFJ/WAS..., EPHFJ/WAS..			QMA..	Airframe spherical plain bearings – Metal-to-metal swaged split (metric dimensions),bronze beryllium inner ring and corrosion-resistant-steel outer ring not plated	2.5	168
PHUMJ/XRE..	For the cross-reference designation of this legacy product, see PHMJ/NAS..., EPHMJ/NAS..			QME..	Airframe spherical plain bearings – Metal-to-metal swaged narrow (metric dimensions),bronze beryllium inner ring and corrosion-resistant-steel outer ring not plated	2.6	172
PHUMJ/XRL..	For the cross-reference designation of this legacy product, see PHMJ/WAS..., EPHMJ/WAS..			QME..	Airframe spherical plain bearings – Metal-to-metal swaged narrow (inch dimensions),bronze beryllium inner ring and corrosion-resistant-steel outer ring not plated	2.11	186
Q2PL..	Airframe spherical plain bearings – Metal-to-metal swaged split (metric dimensions),bronze beryllium inner ring and corrosion-resistant-steel outer ring not plated	2.9	182	QML..	Airframe spherical plain bearings – Metal-to-metal swaged wide (metric dimensions),bronze beryllium inner ring and corrosion-resistant-steel outer ring not plated	2.7	176
Q2PL..	Airframe spherical plain bearings – Metal-to-metal swaged split (inch dimensions),bronze beryllium inner ring and corrosion-resistant-steel outer ring not plated	2.17	210	QML..	Airframe spherical plain bearings – Metal-to-metal swaged wide (inch dimensions),bronze beryllium inner ring and corrosion-resistant-steel outer ring not plated	2.13	194
QEF..	Airframe rod ends – Internal thread integrated metal-to-metal spherical plain bearing rod end (metric dimensions), bronze beryllium inner ring and corrosion-resistant-steel rod end body	3.8	316	QML..	For rod ends using this bearing, see EMJ/QML..., SEMJ/QML..., SEMJ/QML..., TEMJ/QML..., EFJ/QML..., SEFJ/QML..., SEFJ/QML..., TEFJ/QML..., EMJ/QML..R, SEMJ/QML..R, SEMJ/QML..R, TEMJ/QML..R, EFJ/QML..R, SEFJ/QML..R, SEFJ/QML..R, TEFJ/QML..R, EMJ/QML..R, SEMJ/QML..R, XEMJ/QML..R, TEMJ/QML..R, EFJ/QML..R, SEFJ/QML..R, XEFJ/QML..R, TEFJ/QML..R, EMJ/QMLC..R, SEMJ/QMLC..R, XEMJ/QMLC..R, TEMJ/QMLC..R, EFJ/QMLC..R, SEFJ/QMLC..R, XEFJ/QMLC..R, TEFJ/QMLC..R		
QEM..	Airframe rod ends – External thread integrated metal-to-metal spherical plain bearing rod end (metric dimensions), bronze beryllium inner ring and corrosion-resistant-steel rod end body	3.8	310				
QGE..	Airframe spherical plain bearings – Metal-to-metal loader slot (metric dimensions), bronze beryllium inner ring and corrosion-resistant-steel outer ring not plated	2.1	156				
QGL..	Airframe spherical plain bearings – Metal-to-metal loader slot normal, (metric dimensions), bronze beryllium inner ring and corrosion-resistant-steel outer ring not plated	2.2	160				
QGLD..	Airframe spherical plain bearings – Metal-to-metal loader slot normal, (metric dimensions), bronze beryllium inner ring and corrosion-resistant-steel outer ring not plated	2.2	160				
QGLS..	Airframe spherical plain bearings – Metal-to-metal loader slot normal, (metric dimensions), bronze beryllium inner ring and corrosion-resistant-steel outer ring not plated	2.2	160				

¹⁾ Starting page of the product table.

Designation	Product	Product table		Designation	Product	Product table	
		No.	Page ¹⁾			No.	Page ¹⁾
QMT..	Airframe spherical plain bearings – Metal-to-metal swaged high misalignment (metric dimensions), bronze beryllium inner ring and corrosion-resistant-steel outer ring not plated	2.8	180	REP..FL..	Airframe rod ends – Internal thread rod end with integrated rolling bearing, AS 21153 (inch dimensions), bearing in bearing steel and rod end body in cadmium plated steel with left-hand thread	3.17	334
QMT..	Airframe spherical plain bearings – Metal-to-metal swaged high misalignment (inch dimensions), bronze beryllium inner ring and corrosion-resistant-steel outer ring not plated	2.15	202	REP..L..	Airframe rod ends – Internal thread rod end with integrated rolling bearing, AS 21153 (inch dimensions), bearing in bearing steel and rod end body in cadmium plated steel with left-hand thread	3.17	334
QMT..	For rod ends using this bearing, see EMJ/QMT.., SEMJ/QMT.., SEMJ/QMT.., TEMJ/QMT.., EFJ/QMT.., SEFJ/QMT.., SEFJ/QMT.., TEFJ/QMT.., EMJ/QMT..R, SEMJ/QMT..R, SEMJ/QMT..R, TEMJ/QMT..R, EFJ/QMT..R, SEFJ/QMT..R, SEFJ/QMT..R, TEFJ/QMT..R, EMJ/QMTS..R, SEMJ/QMTS..R, XEMJ/QMTS..R, TEMJ/QMTS..R, EFJ/QMTS..R, SEFJ/QMTS..R, XEFJ/QMTS..R, TEFJ/QMTS..R, EMJ/QMTC..R, SEMJ/QMTC..R, XEMJ/QMTC..R, TEMJ/QMTC..R, EFJ/QMTC..R, SEFJ/QMTC..R, XEFJ/QMTC..R, TEFJ/QMTC..R			REP..M..	Airframe rod ends – External thread rod end with integrated rolling bearing, AS 21151 (inch dimensions), bearing in bearing steel and rod end body in cadmium plated steel with right-hand thread	3.16	332
QXMB..	Airframe spherical plain bearings – Metal-to-metal swaged, AS 81936/1, AS 81936/2 (inch dimensions), not plated	2.16	206	REP..ML..	Airframe rod ends – External thread rod end with integrated rolling bearing, AS 21151 (inch dimensions), bearing in bearing steel and rod end body in cadmium plated steel with left-hand thread	3.16	332
RA..M..	Airframe rod ends – External thread rod end with integrated rolling bearing, AS 21151 (inch dimensions), bearing in bearing steel and rod end body in cadmium plated steel with right-hand thread	3.16	332	REP..MR..	Airframe rod ends – External thread rod end with integrated rolling bearing, AS 21151 (inch dimensions), bearing in bearing steel and rod end body in cadmium plated steel with right-hand thread	3.16	332
RA..ML..	Airframe rod ends – External thread rod end with integrated rolling bearing, AS 21151 (inch dimensions), bearing in bearing steel and rod end body in cadmium plated steel with left-hand thread	3.16	332	R..F..	Airframe rod ends – Internal thread self-lubricating spherical plain bearing rod end, NSA 8149 (inch dimensions)	3.29	366
RAP..M..	Airframe rod ends – External thread rod end with integrated rolling bearing, AS 21151 (inch dimensions), bearing in bearing steel and rod end body in cadmium plated steel with right-hand thread	3.16	332	R..F..	For the bearing used in this rod end, see SW..		
RAP..ML..	Airframe rod ends – External thread rod end with integrated rolling bearing, AS 21151 (inch dimensions), bearing in bearing steel and rod end body in cadmium plated steel with left-hand thread	3.16	332	RL..SP...	For the cross-reference designation of this legacy product, see HMEN..		
REP..	Airframe rod ends – Internal thread rod end with integrated rolling bearing, AS 21153 (inch dimensions), bearing in bearing steel and rod end body in cadmium plated steel with right-hand thread	3.17	334	R..M..	Airframe rod ends – External thread self-lubricating spherical plain bearing rod end, NSA 8143 (inch dimensions)	3.22	344
REP..F..	Airframe rod ends – Internal thread rod end with integrated rolling bearing, AS 21153 (inch dimensions), bearing in bearing steel and rod end body in cadmium plated steel with right-hand thread	3.17	334	R..M..	For the bearing used in this rod end, see SW..		
				SB5..	Airframe rolling bearings – Deep groove ball bearing single row, AS 27646 (inch dimensions), zinc-nickel plated bearing steel, standard tolerance	1.18	92
				SB55..	Airframe rolling bearings – Deep groove ball bearing double row (inch dimensions), zinc-nickel plated bearing steel	1.19	96
				SC..M	Airframe rod ends – External thread rod end with integrated rolling bearing (metric dimensions), shielded bearing in bearing steel and rod end body in zinc-nickel plated steel	3.2	298
				SC..ME	Airframe rod ends – External thread rod end with integrated rolling bearing (metric dimensions), sealed bearing in bearing steel and rod end body in zinc-nickel plated steel	3.2	298
				SC..MJ..	Airframe rod ends – External thread rod end with integrated rolling bearing (metric dimensions), bearing in bearing steel and rod end body in zinc-nickel plated steel	3.1	296

¹⁾ Starting page of the product table.

Designation	Product	Product table		Designation	Product	Product table	
		No.	Page ¹⁾			No.	Page ¹⁾
SCN...-..	Airframe rod ends – External thread rod end with integrated rolling bearing (inch dimensions), shielded bearing in bearing steel and rod end body in zinc-nickel plated steel	3.15	326	SDSRP..	Airframe rolling bearings – Spherical roller bearing single row (inch dimensions), zinc-nickel plated bearing steel	1.27	116
SCN..E..	Airframe rod ends – External thread rod end with integrated rolling bearing (inch dimensions), sealed bearing in bearing steel and rod end body in zinc-nickel plated steel	3.15	326	SDW..	Airframe rolling bearings – Deep groove ball bearing double row, AS 27647 (inch dimensions), zinc-nickel plated bearing steel, standard tolerance	1.21	100
SCN..JESP..	Airframe rod ends – External thread rod end with integrated rolling bearing (inch dimensions), sealed bearing in bearing steel and rod end body in zinc-nickel plated steel with UNJF profile thread	3.14	322	SDW..K	Airframe rolling bearings – Deep groove ball bearing double row, AS 27647 (inch dimensions), zinc-nickel plated bearing steel, standard tolerance	1.21	100
SCN..JSP..	Airframe rod ends – External thread rod end with integrated rolling bearing (inch dimensions), shielded bearing in bearing steel and rod end body in zinc-nickel plated steel with UNJF profile thread	3.14	322	SDW..K2	Airframe rolling bearings – Deep groove ball bearing double row, AS 27647 (inch dimensions), zinc-nickel plated bearing steel, standard tolerance	1.21	100
SCN..M	Airframe rod ends – External thread rod end with integrated rolling bearing (metric dimensions), shielded bearing in bearing steel and rod end body in zinc-nickel plated steel	3.2	298	SEF..	Airframe rod ends – Internal thread integrated metal-to-metal spherical plain bearing rod end (metric dimensions), zinc-nickel plated steel inner ring and zinc-nickel plated steel rod end body	3.8	316
SCN..ME	Airframe rod ends – External thread rod end with integrated rolling bearing (metric dimensions), sealed bearing in bearing steel and rod end body in zinc-nickel plated steel	3.2	298	SEFJ/NAS..	Airframe rod ends – Internal thread inserted narrow self-lubricating spherical plain bearing rod end (inch dimensions), PH13.8 inner ring and zinc-nickel plated 4340 steel rod end body	3.27	358
SCN..MESP..	Airframe rod ends – External thread rod end with integrated rolling bearing (inch dimensions), sealed bearing in bearing steel and rod end body in zinc-nickel plated steel with UNF profile thread	3.14	322	SEFJ/NAS..	For the bearing used in this rod end, see NAS..		
SCN..MESP1	Airframe rod ends – External thread rod end with integrated rolling bearing (metric dimensions), sealed bearing in bearing steel and rod end body in zinc-nickel plated steel	3.2	298	SEFJ/QML..	Airframe rod ends – Internal thread inserted wide metal-to-metal spherical plain bearing rod end (metric dimensions), zinc-nickel plated steel rod end body, bronze beryllium inner ring and corrosion-resistant-steel outer ring	3.12	318
SCN..MJ..	Airframe rod ends – External thread rod end with integrated rolling bearing (metric dimensions), bearing in bearing steel and rod end body in zinc-nickel plated steel	3.1	296	SEFJ/QML..	For the bearing used in this rod end, see QML..		
SCN..MSP..	Airframe rod ends – External thread rod end with integrated rolling bearing (inch dimensions), shielded bearing in bearing steel and rod end body in zinc-nickel plated steel with UNF profile thread	3.14	322	SEFJ/QML..	Airframe rod ends – Internal thread inserted wide metal-to-metal spherical plain bearing rod end (metric dimensions), corrosion-resistant-steel rod end body, bronze beryllium inner ring and corrosion-resistant-steel outer ring	3.12	318
SCN..MSP1	Airframe rod ends – External thread rod end with integrated rolling bearing (metric dimensions), shielded bearing in bearing steel and rod end body in zinc-nickel plated steel	3.2	298	SEFJ/QML..R	Airframe rod ends – Internal thread inserted wide metal-to-metal spherical plain bearing rod end (inch dimensions), zinc-nickel plated steel rod end body, bronze beryllium inner ring and corrosion-resistant-steel outer ring with lubrication by the rod end body	3.34	378
SDPP..	Airframe rolling bearings – Deep groove ball bearing double row, AS 27644 (inch dimensions), zinc-nickel plated bearing steel, standard tolerance	1.20	98	SEFJ/QMLC..R	For the bearing used in this rod end, see QML..		
SDSP..	Airframe rolling bearings – Self-aligning ball bearing double row, AS 27643 (inch dimensions), zinc-nickel plated bearing steel, standard tolerance	1.26	114	SEFJ/QML..R	Airframe rod ends – Internal thread inserted wide metal-to-metal spherical plain bearing rod end (inch dimensions), zinc-nickel plated steel rod end body, bronze beryllium inner ring and corrosion-resistant-steel outer ring without lubrication groove	3.34	378
				SEFJ/QML..R	For the bearing used in this rod end, see QML..		

¹⁾ Starting page of the product table.

Designation	Product	Product table		Designation	Product	Product table	
		No.	Page ¹⁾			No.	Page ¹⁾
SEFJ/QMLS..R	Airframe rod ends – Internal thread inserted wide metal-to-metal spherical plain bearing rod end (inch dimensions), zinc-nickel plated steel rod end body, bronze beryllium inner ring and corrosion-resistant-steel outer ring with lubrication by the inner ring	3.34	378	SEFJ/RT..	For the bearing used in this rod end, see XRT..		
SEFJ/QMLS..R	For the bearing used in this rod end, see QML..			SEFJ/RT..R..	Airframe rod ends – Internal thread inserted high-misalignment self-lubricating spherical plain bearing rod end (inch dimensions), zinc-nickel plated 30NCD16 steel rod end	3.31	372
SEFJ/QMT..	Airframe rod ends – Internal thread inserted high misalignment metal-to-metal spherical plain bearing rod end (metric dimensions), zinc-nickel plated steel rod end body, bronze beryllium inner ring and corrosion-resistant-steel outer ring	3.13	320	SEFJ/RT..R..	For the bearing used in this rod end, see XRT..		
SEFJ/QMT..	For the bearing used in this rod end, see QMT..			SEFJ/WAS..	Airframe rod ends – Internal thread inserted wide self-lubricating spherical plain bearing rod end (inch dimensions), PH13.8 inner ring and zinc-nickel plated 4340 steel rod end body	3.25	350
SEFJ/QMT..	Airframe rod ends – Internal thread inserted high misalignment metal-to-metal spherical plain bearing rod end (metric dimensions), corrosion-resistant-steel rod end body, bronze beryllium inner ring and corrosion-resistant-steel outer ring	3.13	320	SEFJ/WAS..	For the bearing used in this rod end, see WAS..		
SEFJ/QMT..	For the bearing used in this rod end, see QMT..			SEFJ/WML..	Airframe rod ends – Internal thread inserted wide metal-to-metal spherical plain bearing rod end (metric dimensions), zinc-nickel plated steel rod end body, corrosion-resistant-steel inner ring and corrosion-resistant-steel outer ring	3.12	318
SEFJ/QMTC..R	Airframe rod ends – Internal thread inserted high misalignment metal-to-metal spherical plain bearing rod end (inch dimensions), zinc-nickel plated steel rod end body, bronze beryllium inner ring and corrosion-resistant-steel outer ring with lubrication by the rod end body	3.35	380	SEFJ/WML..	For the bearing used in this rod end, see WML..		
SEFJ/QMTC..R	For the bearing used in this rod end, see QMT..			SEFJ/WML..	Airframe rod ends – Internal thread inserted wide metal-to-metal spherical plain bearing rod end (metric dimensions), corrosion-resistant-steel rod end body, corrosion-resistant-steel inner ring and corrosion-resistant-steel outer ring	3.12	318
SEFJ/QMT..R	Airframe rod ends – Internal thread inserted high misalignment metal-to-metal spherical plain bearing rod end (inch dimensions), zinc-nickel plated steel rod end body, bronze beryllium inner ring and corrosion-resistant-steel outer ring without lubrication groove	3.35	380	SEFJ/WML..	For the bearing used in this rod end, see WML..		
SEFJ/QMT..R	For the bearing used in this rod end, see QMT..			SEFJ/WMLC..R	Airframe rod ends – Internal thread inserted wide metal-to-metal spherical plain bearing rod end (inch dimensions), zinc-nickel plated steel rod end body, corrosion-resistant-steel inner ring and corrosion-resistant-steel outer ring with lubrication by the rod end body	3.34	378
SEFJ/QMTS..R	Airframe rod ends – Internal thread inserted high misalignment metal-to-metal spherical plain bearing rod end (inch dimensions), zinc-nickel plated steel rod end body, bronze beryllium inner ring and corrosion-resistant-steel outer ring with lubrication by the inner ring	3.35	380	SEFJ/WMLC..R	For the bearing used in this rod end, see WML..		
SEFJ/QMTS..R	For the bearing used in this rod end, see QMT..			SEFJ/WML..R	Airframe rod ends – Internal thread inserted wide metal-to-metal spherical plain bearing rod end (inch dimensions), zinc-nickel plated steel rod end body, corrosion-resistant-steel inner ring and corrosion-resistant-steel outer ring without lubrication groove	3.34	378
SEFJ/RL..	Airframe rod ends – Internal thread inserted wide self-lubricating spherical plain bearing rod end (metric dimensions), zinc-nickel plated 30NCD16 steel rod end	3.6	306	SEFJ/WML..R	For the bearing used in this rod end, see WML..		
SEFJ/RL..	For the bearing used in this rod end, see WEN..			SEFJ/WMLS..R	Airframe rod ends – Internal thread inserted wide metal-to-metal spherical plain bearing rod end (inch dimensions), zinc-nickel plated steel rod end body, corrosion-resistant-steel inner ring and corrosion-resistant-steel outer ring with lubrication by the inner ring	3.34	378
SEFJ/RT..	Airframe rod ends – Internal thread inserted high-misalignment self-lubricating spherical plain bearing rod end (metric dimensions), zinc-nickel plated 30NCD16 steel rod end	3.7	308	SEFJ/WMLS..R	For the bearing used in this rod end, see WML..		

¹⁾ Starting page of the product table.

Designation	Product	Product table		Designation	Product	Product table	
		No.	Page ¹⁾			No.	Page ¹⁾
SEFJ/WMT..	Airframe rod ends – Internal thread inserted high misalignment metal-to-metal spherical plain bearing rod end (metric dimensions), zinc-nickel plated steel rod end body, corrosion-resistant-steel inner ring and corrosion-resistant-steel outer ring	3.13	320	SEFJ/WQMLC..R	Airframe rod ends – Internal thread inserted wide metal-to-metal spherical plain bearing rod end (inch dimensions), zinc-nickel plated steel rod end body, corrosion-resistant-steel inner ring and bronze aluminium outer ring with lubrication by the rod end body	3.34	378
SEFJ/WMT..	For the bearing used in this rod end, see WMT..			SEFJ/WQMLC..R	For the bearing used in this rod end, see WQML..		
SEFJ/WMT..	Airframe rod ends – Internal thread inserted high misalignment metal-to-metal spherical plain bearing rod end (metric dimensions), corrosion-resistant-steel rod end body, corrosion-resistant-steel inner ring and corrosion-resistant-steel outer ring	3.13	320	SEFJ/WQML..R	Airframe rod ends – Internal thread inserted wide metal-to-metal spherical plain bearing rod end (inch dimensions), zinc-nickel plated steel rod end body, corrosion-resistant-steel inner ring and bronze aluminium outer ring without lubrication groove	3.34	378
SEFJ/WMT..	For the bearing used in this rod end, see WMT..			SEFJ/WQML..R	For the bearing used in this rod end, see WQML..		
SEFJ/WMTC..R	Airframe rod ends – Internal thread inserted high misalignment metal-to-metal spherical plain bearing rod end (inch dimensions), zinc-nickel plated steel rod end body, corrosion-resistant-steel inner ring and corrosion-resistant-steel outer ring with lubrication by the rod end body	3.35	380	SEFJ/WQMLS..R	Airframe rod ends – Internal thread inserted wide metal-to-metal spherical plain bearing rod end (inch dimensions), zinc-nickel plated steel rod end body, corrosion-resistant-steel inner ring and bronze aluminium outer ring with lubrication by the inner ring	3.34	378
SEFJ/WMTC..R	For the bearing used in this rod end, see WMT..			SEFJ/WQMLS..R	For the bearing used in this rod end, see WQML..		
SEFJ/WMT..R	Airframe rod ends – Internal thread inserted high misalignment metal-to-metal spherical plain bearing rod end (inch dimensions), zinc-nickel plated steel rod end body, corrosion-resistant-steel inner ring and corrosion-resistant-steel outer ring without lubrication groove	3.35	380	SEFJ/WQMT..	Airframe rod ends – Internal thread inserted high misalignment metal-to-metal spherical plain bearing rod end (metric dimensions), zinc-nickel plated steel rod end body, corrosion-resistant-steel inner ring and bronze aluminium outer ring	3.13	320
SEFJ/WMT..R	For the bearing used in this rod end, see WMT..			SEFJ/WQMT..	For the bearing used in this rod end, see WQMT..		
SEFJ/WMTS..R	Airframe rod ends – Internal thread inserted high misalignment metal-to-metal spherical plain bearing rod end (inch dimensions), zinc-nickel plated steel rod end body, corrosion-resistant-steel inner ring and corrosion-resistant-steel outer ring with lubrication by the inner ring	3.35	380	SEFJ/WQMT..	Airframe rod ends – Internal thread inserted high misalignment metal-to-metal spherical plain bearing rod end (metric dimensions), corrosion-resistant-steel rod end body, corrosion-resistant-steel inner ring and bronze aluminium outer ring	3.13	320
SEFJ/WMTS..R	For the bearing used in this rod end, see WMT..			SEFJ/WQMT..	For the bearing used in this rod end, see WQMT..		
SEFJ/WQML..	Airframe rod ends – Internal thread inserted wide metal-to-metal spherical plain bearing rod end (metric dimensions), zinc-nickel plated steel rod end body, corrosion-resistant-steel inner ring and bronze aluminium outer ring	3.12	318	SEFJ/WQMTC..R	Airframe rod ends – Internal thread inserted high misalignment metal-to-metal spherical plain bearing rod end (inch dimensions), zinc-nickel plated steel rod end body, corrosion-resistant-steel inner ring and bronze aluminium outer ring with lubrication by the rod end body	3.35	380
SEFJ/WQML..	For the bearing used in this rod end, see WQML..			SEFJ/WQMTC..R	For the bearing used in this rod end, see WQMT..		
SEFJ/WQML..	Airframe rod ends – Internal thread inserted wide metal-to-metal spherical plain bearing rod end (metric dimensions), corrosion-resistant-steel rod end body, corrosion-resistant-steel inner ring and bronze aluminium outer ring	3.12	318	SEFJ/WQMT..R	Airframe rod ends – Internal thread inserted high misalignment metal-to-metal spherical plain bearing rod end (inch dimensions), zinc-nickel plated steel rod end body, corrosion-resistant-steel inner ring and bronze aluminium outer ring without lubrication groove	3.35	380
SEFJ/WQML..	For the bearing used in this rod end, see WQML..			SEFJ/WQMT..R	For the bearing used in this rod end, see WQMT..		

¹⁾ Starting page of the product table.

Designation	Product	Product table No. Page ¹⁾	Designation	Product	Product table No. Page ¹⁾
SEFJ/WQMTS..R	Airframe rod ends – Internal thread inserted high misalignment metal-to-metal spherical plain bearing rod end (inch dimensions), zinc-nickel plated steel rod end body, corrosion-resistant-steel inner ring and bronze aluminium outer ring with lubrication by the inner ring	3.35 380	SEMJ/QMLS..R	Airframe rod ends – External thread inserted wide metal-to-metal spherical plain bearing rod end (inch dimensions), zinc-nickel plated steel rod end body, bronze beryllium inner ring and corrosion-resistant-steel outer ring with lubrication by the inner ring	3.32 374
SEFJ/WQMTS..R	For the bearing used in this rod end, see WQMT..		SEMJ/QMLS..R	For the bearing used in this rod end, see QML..	
SEM..	Airframe rod ends – External thread integrated metal-to-metal spherical plain bearing rod end (metric dimensions), zinc-nickel plated steel inner ring and zinc-nickel plated steel rod end body	3.8 310	SEMJ/QMT..	Airframe rod ends – External thread inserted high misalignment metal-to-metal spherical plain bearing rod end (metric dimensions), zinc-nickel plated steel rod end body, bronze beryllium inner ring and corrosion-resistant-steel outer ring	3.10 314
SEMA..	Airframe rod ends – External thread inserted self-lubricating spherical plain bearing rod end (metric dimensions), zinc-nickel plated 30NCD16 steel rod end	3.3 300	SEMJ/QMT..	For the bearing used in this rod end, see QMT..	
SEMA..	For the bearing used in this rod end, see HMEN..R..		SEMJ/QMT..	Airframe rod ends – External thread inserted high misalignment metal-to-metal spherical plain bearing rod end (metric dimensions), corrosion-resistant-steel rod end body, bronze beryllium inner ring and corrosion-resistant-steel outer ring	3.10 314
SEMJ/NAS..	Airframe rod ends – External thread inserted narrow self-lubricating spherical plain bearing rod end (inch dimensions), PH13.8 inner ring and zinc-nickel plated 4340 steel rod end body	3.20 340	SEMJ/QMT..	For the bearing used in this rod end, see QMT..	
SEMJ/NAS..	For the bearing used in this rod end, see ENAS..		SEMJ/QMTC..R	Airframe rod ends – External thread inserted high misalignment metal-to-metal spherical plain bearing rod end (inch dimensions), zinc-nickel plated steel rod end body, bronze beryllium inner ring and corrosion-resistant-steel outer ring with lubrication by the rod end body	3.33 376
SEMJ/QML..	Airframe rod ends – External thread inserted wide metal-to-metal spherical plain bearing rod end (metric dimensions), zinc-nickel plated steel rod end body, bronze beryllium inner ring and corrosion-resistant-steel outer ring	3.9 312	SEMJ/QMTC..R	For the bearing used in this rod end, see QMT..	
SEMJ/QML..	For the bearing used in this rod end, see QML..		SEMJ/QMT..R	Airframe rod ends – External thread inserted high misalignment metal-to-metal spherical plain bearing rod end (inch dimensions), zinc-nickel plated steel rod end body, bronze beryllium inner ring and corrosion-resistant-steel outer ring without lubrication groove	3.33 376
SEMJ/QML..	Airframe rod ends – External thread inserted wide metal-to-metal spherical plain bearing rod end (metric dimensions), corrosion-resistant-steel rod end body, bronze beryllium inner ring and corrosion-resistant-steel outer ring	3.9 312	SEMJ/QMT..R	For the bearing used in this rod end, see QMT..	
SEMJ/QML..	For the bearing used in this rod end, see QML..		SEMJ/QMTS..R	Airframe rod ends – External thread inserted high misalignment metal-to-metal spherical plain bearing rod end (inch dimensions), zinc-nickel plated steel rod end body, bronze beryllium inner ring and corrosion-resistant-steel outer ring with lubrication by the inner ring	3.33 376
SEMJ/QMLC..R	Airframe rod ends – External thread inserted wide metal-to-metal spherical plain bearing rod end (inch dimensions), zinc-nickel plated steel rod end body, bronze beryllium inner ring and corrosion-resistant-steel outer ring with lubrication by the rod end body	3.32 374	SEMJ/QMTS..R	For the bearing used in this rod end, see QMT..	
SEMJ/QMLC..R	For the bearing used in this rod end, see QML..		SEMJ/RL..	Airframe rod ends – External thread inserted wide self-lubricating spherical plain bearing rod end (metric dimensions), zinc-nickel plated 30NCD16 steel rod end	3.4 302
SEMJ/QML..R	Airframe rod ends – External thread inserted wide metal-to-metal spherical plain bearing rod end (inch dimensions), zinc-nickel plated steel rod end body, bronze beryllium inner ring and corrosion-resistant-steel outer ring without lubrication groove	3.32 374	SEMJ/RL..	For the bearing used in this rod end, see WEN..	
SEMJ/QML..R	For the bearing used in this rod end, see QML..		SEMJ/RL..R..	Airframe rod ends – External thread inserted wide self-lubricating spherical plain bearing rod end (inch dimensions), zinc-nickel plated 30NCD16 steel rod end	3.23 346
			SEMJ/RL..R..	For the bearing used in this rod end, see WAS..	

¹⁾ Starting page of the product table.

Designation	Product	Product table		Designation	Product	Product table	
		No.	Page ¹⁾			No.	Page ¹⁾
SEMJ/RT..	Airframe rod ends – External thread inserted high-misalignment self-lubricating spherical plain bearing rod end (metric dimensions), zinc-nickel plated 30NCD16 steel rod end	3.5	304	SEMJ/WMT..	Airframe rod ends – External thread inserted high misalignment metal-to-metal spherical plain bearing rod end (metric dimensions), zinc-nickel plated steel rod end body, corrosion-resistant-steel inner ring and corrosion-resistant-steel outer ring	3.10	314
SEMJ/RT..	For the bearing used in this rod end, see XRT..			SEMJ/WMT..	For the bearing used in this rod end, see WMT..		
SEMJ/RT..R..	Airframe rod ends – External thread inserted high-misalignment self-lubricating spherical plain bearing rod end (inch dimensions), zinc-nickel plated 30NCD16 steel rod end	3.24	348	SEMJ/WMT..	Airframe rod ends – External thread inserted high misalignment metal-to-metal spherical plain bearing rod end (metric dimensions), corrosion-resistant-steel rod end body, corrosion-resistant-steel inner ring and corrosion-resistant-steel outer ring	3.10	314
SEMJ/RT..R..	For the bearing used in this rod end, see XRT..			SEMJ/WMT..	For the bearing used in this rod end, see WMT..		
SEMJ/WAS..	Airframe rod ends – External thread inserted wide self-lubricating spherical plain bearing rod end (inch dimensions), PH13.8 inner ring and zinc-nickel plated 4340 steel rod end body	3.18	336	SEMJ/WMT..	Airframe rod ends – External thread inserted high misalignment metal-to-metal spherical plain bearing rod end (inch dimensions), zinc-nickel plated steel rod end body, corrosion-resistant-steel inner ring and corrosion-resistant-steel outer ring with lubrication by the rod end body	3.33	376
SEMJ/WAS..	For the bearing used in this rod end, see EWAS..			SEMJ/WMT..R	For the bearing used in this rod end, see WMT..		
SEMJ/WML..	Airframe rod ends – External thread inserted wide metal-to-metal spherical plain bearing rod end (metric dimensions), zinc-nickel plated steel rod end body, corrosion-resistant-steel inner ring and corrosion-resistant-steel outer ring	3.9	312	SEMJ/WMT..R	Airframe rod ends – External thread inserted high misalignment metal-to-metal spherical plain bearing rod end (inch dimensions), zinc-nickel plated steel rod end body, corrosion-resistant-steel inner ring and corrosion-resistant-steel outer ring without lubrication groove	3.33	376
SEMJ/WML..	For the bearing used in this rod end, see WML..			SEMJ/WMT..R	For the bearing used in this rod end, see WMT..		
SEMJ/WML..	Airframe rod ends – External thread inserted wide metal-to-metal spherical plain bearing rod end (metric dimensions), corrosion-resistant-steel inner ring and corrosion-resistant-steel outer ring	3.9	312	SEMJ/WMT..R	Airframe rod ends – External thread inserted high misalignment metal-to-metal spherical plain bearing rod end (inch dimensions), zinc-nickel plated steel rod end body, corrosion-resistant-steel inner ring and corrosion-resistant-steel outer ring with lubrication by the inner ring	3.33	376
SEMJ/WML..	For the bearing used in this rod end, see WML..			SEMJ/WMT..R	For the bearing used in this rod end, see WMT..		
SEMJ/WMLC..R	Airframe rod ends – External thread inserted wide metal-to-metal spherical plain bearing rod end (inch dimensions), zinc-nickel plated steel rod end body, corrosion-resistant-steel inner ring and corrosion-resistant-steel outer ring with lubrication by the rod end body	3.32	374	SEMJ/WMTS..R	Airframe rod ends – External thread inserted wide metal-to-metal spherical plain bearing rod end (metric dimensions), zinc-nickel plated steel rod end body, corrosion-resistant-steel inner ring and bronze aluminium outer ring	3.9	312
SEMJ/WMLC..R	For the bearing used in this rod end, see WML..			SEMJ/WQML..	For the bearing used in this rod end, see WQML..		
SEMJ/WML..R	Airframe rod ends – External thread inserted wide metal-to-metal spherical plain bearing rod end (inch dimensions), zinc-nickel plated steel rod end body, corrosion-resistant-steel inner ring and corrosion-resistant-steel outer ring without lubrication groove	3.32	374	SEMJ/WQML..	Airframe rod ends – External thread inserted wide metal-to-metal spherical plain bearing rod end (metric dimensions), corrosion-resistant-steel rod end body, corrosion-resistant-steel inner ring and bronze aluminium outer ring	3.9	312
SEMJ/WML..R	For the bearing used in this rod end, see ML..			SEMJ/WQML..	For the bearing used in this rod end, see WQML..		
SEMJ/WMLS..R	Airframe rod ends – External thread inserted wide metal-to-metal spherical plain bearing rod end (inch dimensions), zinc-nickel plated steel rod end body, corrosion-resistant-steel inner ring and corrosion-resistant-steel outer ring with lubrication by the inner ring	3.32	374	SEMJ/WQML..	For the bearing used in this rod end, see WQML..		
SEMJ/WMLS..R	For the bearing used in this rod end, see WML..						

¹⁾ Starting page of the product table.

Designation	Product	Product table No. Page ¹⁾	Designation	Product	Product table No. Page ¹⁾
SEMJ/WQMLC..R	Airframe rod ends – External thread inserted wide metal-to-metal spherical plain bearing rod end (inch dimensions), zinc-nickel plated steel rod end body, corrosion-resistant-steel inner ring and bronze aluminium outer ring with lubrication by the rod end body	3.32 374	SEMJ/WQMTS..R	Airframe rod ends – External thread inserted high misalignment metal-to-metal spherical plain bearing rod end (inch dimensions), zinc-nickel plated steel rod end body, corrosion-resistant-steel inner ring and bronze aluminium outer ring with lubrication by the inner ring	3.33 376
SEMJ/WQMLC..R	For the bearing used in this rod end, see WQML..		SEMJ/WQMTS..R	For the bearing used in this rod end, see WQMT..	
SEMJ/WQML..R	Airframe rod ends – External thread inserted wide metal-to-metal spherical plain bearing rod end (inch dimensions), zinc-nickel plated steel rod end body, corrosion-resistant-steel inner ring and bronze aluminium outer ring without lubrication groove	3.32 374	SFJ/NAS..	Airframe rod ends – Internal thread inserted narrow self-lubricating spherical plain bearing rod end (inch dimensions), 440C inner ring and zinc-nickel plated 4340 steel rod end body	3.27 358
SEMJ/WQML..R	For the bearing used in this rod end, see WQML..		SFJ/NAS..	For the bearing used in this rod end, see NAS..	
SEMJ/WQMLS..R	Airframe rod ends – External thread inserted wide metal-to-metal spherical plain bearing rod end (inch dimensions), zinc-nickel plated steel rod end body, corrosion-resistant-steel inner ring and bronze aluminium outer ring with lubrication by the inner ring	3.32 374	SFJ/WAS..	Airframe rod ends – Internal thread inserted wide self-lubricating spherical plain bearing rod end (inch dimensions), 440C inner ring and zinc-nickel plated 4340 steel rod end body	3.25 350
SEMJ/WQMLS..R	For the bearing used in this rod end, see WQML..		SFJ/WAS..	For the bearing used in this rod end, see WAS..	
SEMJ/WQMT..	Airframe rod ends – External thread inserted high misalignment metal-to-metal spherical plain bearing rod end (metric dimensions), zinc-nickel plated steel rod end body, corrosion-resistant-steel inner ring and bronze aluminium outer ring	3.10 314	SH..	Airframe spherical plain bearings – Self-lubricating high misalignment (inch dimensions)	2.31 256
SEMJ/WQMT..	For the bearing used in this rod end, see WQMT..		..SK	Airframe self-lubricating journal bearings – Plain bearings, EN 2287, metric dimensions, corrosion-resistant-steel S.80, liner Fiberslip	4.1 404
SEMJ/WQMT..	Airframe rod ends – External thread inserted high misalignment metal-to-metal spherical plain bearing rod end (metric dimensions), corrosion-resistant-steel rod end body, corrosion-resistant-steel inner ring and bronze aluminium outer ring	3.10 314	SKP..	Airframe rolling bearings – Deep groove ball bearing single row, AS 27640 (inch dimensions), zinc-nickel plated bearing steel, standard tolerance	1.14 78
SEMJ/WQMT..	For the bearing used in this rod end, see WQMT..		SKP..A	Airframe rolling bearings – Deep groove ball bearing single row, AS 27641 (inch dimensions), zinc-nickel plated bearing steel, standard tolerance	1.15 80
SEMJ/WQMT..R	Airframe rod ends – External thread inserted high misalignment metal-to-metal spherical plain bearing rod end (inch dimensions), zinc-nickel plated steel rod end body, corrosion-resistant-steel inner ring and bronze aluminium outer ring with lubrication by the rod end body	3.33 376	SKP..APSP..	Airframe rolling bearings – Deep groove ball bearing single row (inch dimensions), zinc-nickel plated bearing steel, shielded	1.17 90
SEMJ/WQMT..R	For the bearing used in this rod end, see WQMT..		SKP..ASP..	Airframe rolling bearings – Deep groove ball bearing single row inch dimensions), zinc-nickel plated bearing steel, sealed	1.17 90
SEMJ/WQMT..R	Airframe rod ends – External thread inserted high misalignment metal-to-metal spherical plain bearing rod end (inch dimensions), zinc-nickel plated steel rod end body, corrosion-resistant-steel inner ring and bronze aluminium outer ring without lubrication groove	3.33 376	SKP..B	Airframe rolling bearings – Deep groove ball bearing single row, AS 27642 (inch dimensions), zinc-nickel plated bearing steel, standard tolerance	1.16 84
SEMJ/WQMT..R	For the bearing used in this rod end, see WQMT..		SKP..BS	Airframe rolling bearings – Deep groove ball bearing with self-aligning ring single row, AS 27648 (inch dimensions), zinc-nickel plated bearing steel, standard tolerance	1.22 102
SEMJ/WQMT..R	Airframe rod ends – External thread inserted high misalignment metal-to-metal spherical plain bearing rod end (inch dimensions), zinc-nickel plated steel rod end body, corrosion-resistant-steel inner ring and bronze aluminium outer ring without lubrication groove	3.33 376	SKP..L	Airframe rolling bearings – Deep groove ball bearing single row, AS 27640 (inch dimensions), zinc-nickel plated bearing steel, standard tolerance	1.14 78
SEMJ/WQMT..R	For the bearing used in this rod end, see WQMT..		SKP..LPSP..	Airframe rolling bearings – Deep groove ball bearing single row (inch dimensions), zinc-nickel plated bearing steel, shielded	1.17 90

¹⁾ Starting page of the product table.

Designation	Product	Product table		Designation	Product	Product table	
		No.	Page ¹⁾			No.	Page ¹⁾
SKP..LSP..	Airframe rolling bearings – Deep groove ball bearing single row (inch dimensions), zinc-nickel plated bearing steel, sealed	1.17	90	SMDW..K2	Airframe rolling bearings – Deep groove ball bearing double row (inch dimensions), zinc-nickel plated bearing steel, reduced tolerance and SKF super precision	1.21	100
SKP..PSP..	Airframe rolling bearings – Deep groove ball bearing single row (inch dimensions), zinc-nickel plated bearing steel, shielded	1.17	90	SMJ/NAS..	Airframe rod ends – External thread inserted narrow self-lubricating spherical plain bearing rod end (inch dimensions), 440C inner ring and zinc-nickel plated 4340 steel rod end body	3.20	340
SKP..SP..	Airframe rolling bearings – Deep groove ball bearing single row (inch dimensions), zinc-nickel plated bearing steel, sealed	1.17	90	SMJ/NAS..	For the bearing used in this rod end, see NAS..		
SKSP..	Airframe rolling bearings – Self-aligning ball bearing single row, AS 27645 (inch dimensions), zinc-nickel plated bearing steel, standard tolerance	1.23	106	SMJ/WAS..	Airframe rod ends – External thread inserted wide self-lubricating spherical plain bearing rod end (inch dimensions), 440C inner ring and zinc-nickel plated 4340 steel rod end body	3.18	336
SKSP..A	Airframe rolling bearings – Self-aligning ball bearing single row, AS 27645 (inch dimensions), zinc-nickel plated bearing steel, standard tolerance	1.23	106	SMJ/WAS..	For the bearing used in this rod end, see WAS..		
SKSP..APSP..	Airframe rolling bearings – Self-aligning ball bearing single row (inch dimensions), zinc-nickel plated bearing steel, shielded	1.24	110	SMKP..	Airframe rolling bearings – Deep groove ball bearing single row (inch dimensions), zinc-nickel plated bearing steel, reduced tolerance and SKF super precision	1.14	78
SKSP..ASP..	Airframe rolling bearings – Self-aligning ball bearing single row (inch dimensions), zinc-nickel plated bearing steel, sealed	1.24	110	SMKP..A	Airframe rolling bearings – Deep groove ball bearing single row (inch dimensions), zinc-nickel plated bearing steel, reduced tolerance and SKF super precision	1.15	80
SKSP..L	Airframe rolling bearings – Self-aligning ball bearing single row, AS 27645 (inch dimensions), zinc-nickel plated bearing steel, standard tolerance	1.23	106	SMKP..B	Airframe rolling bearings – Deep groove ball bearing single row (inch dimensions), zinc-nickel plated bearing steel, reduced tolerance and SKF super precision	1.16	84
SKSP..PSP..	Airframe rolling bearings – Self-aligning ball bearing single row (inch dimensions), zinc-nickel plated bearing steel, shielded	1.24	110	SMKP..BS	Airframe rolling bearings – Deep groove ball bearing with self-aligning ring single row (inch dimensions), zinc-nickel plated bearing steel, reduced tolerance and SKF super precision	1.22	102
SKSP..SP..	Airframe rolling bearings – Self-aligning ball bearing single row (inch dimensions), zinc-nickel plated bearing steel, sealed	1.24	110	SMKP..L	Airframe rolling bearings – Deep groove ball bearing single row (inch dimensions), zinc-nickel plated bearing steel, reduced tolerance and SKF super precision	1.14	78
SMB5..	Airframe rolling bearings – Deep groove ball bearing single row, AS 21428 (inch dimensions), zinc-nickel plated bearing steel, reduced clearance and precision	1.18	92	SMKSP..	Airframe rolling bearings – Self-aligning ball bearing single row (inch dimensions), zinc-nickel plated bearing steel, reduced tolerance and SKF super precision	1.23	106
SMDPP..	Airframe rolling bearings – Deep groove ball bearing double row (inch dimensions), zinc-nickel plated bearing steel, reduced tolerance and SKF super precision	1.20	98	SMKSP..A	Airframe rolling bearings – Self-aligning ball bearing single row (inch dimensions), zinc-nickel plated bearing steel, reduced tolerance and SKF super precision	1.23	106
SMDSP..	Airframe rolling bearings – Self-aligning ball bearing double row (inch dimensions), zinc-nickel plated bearing steel, reduced tolerance and SKF super precision	1.26	114	SMKSP..L	Airframe rolling bearings – Self-aligning ball bearing single row (inch dimensions), zinc-nickel plated bearing steel, reduced tolerance and SKF super precision	1.23	106
SMDW..	Airframe rolling bearings – Deep groove ball bearing double row (inch dimensions), zinc-nickel plated bearing steel, reduced tolerance and SKF super precision	1.21	100	SN..	Airframe spherical plain bearings – Self-lubricating narrow, NSA 8134, NSA 8136 (inch dimensions)	2.25	232
SMDW..K	Airframe rolling bearings – Deep groove ball bearing double row (inch dimensions), zinc-nickel plated bearing steel, reduced tolerance and SKF super precision	1.21	100	SN..ZT..	Airframe spherical plain bearings – Self-lubricating narrow controlled clearance (inch dimensions)	2.24	230

¹⁾ Starting page of the product table.

Designation	Product	Product table		Designation	Product	Product table	
		No.	Page ¹⁾			No.	Page ¹⁾
SRA..M..	Airframe rod ends – External thread rod end with integrated rolling bearing, AS 21151 (inch dimensions), bearing in bearing steel and rod end body in zinc-nickel plated steel with right-hand thread	3.16	332	STRCE..	Airframe rolling bearings – Deep groove ball bearing with self-aligning ring single row, EN 3059 (metric dimensions), bearing steel bearing and zinc-nickel plated steel self-aligning ring	1.7	64
SRA..ML..	Airframe rod ends – External thread rod end with integrated rolling bearing, AS 21151 (inch dimensions), bearing in bearing steel and rod end body in zinc-nickel plated steel with left-hand thread	3.16	332	STRCEI..	Airframe rolling bearings – Deep groove ball bearing with self-aligning ring single row (metric dimensions), zinc-nickel plated bearing steel bearing and zinc-nickel plated steel self-aligning ring	1.8	56
SRAP..M..	Airframe rod ends – External thread rod end with integrated rolling bearing, AS 21151 (inch dimensions), bearing in bearing steel and rod end body in zinc-nickel plated steel with right-hand thread	3.16	332	SUFJ/XRE..	For the cross-reference designation of this legacy product, see SFJ/NAS.., SEFJ/NAS..		
SRAP..ML..	Airframe rod ends – External thread rod end with integrated rolling bearing, AS 21151 (inch dimensions), bearing in bearing steel and rod end body in zinc-nickel plated steel with left-hand thread	3.16	332	SUFJ/XRL..	For the cross-reference designation of this legacy product, see SFJ/WAS.., SEFJ/WAS..		
SREP..	Airframe rod ends – Internal thread rod end with integrated rolling bearing, AS 21153 (inch dimensions), bearing in bearing steel and rod end body in zinc-nickel plated steel with right-hand thread	3.17	334	SUMJ/XRE..	For the cross-reference designation of this legacy product, see SMJ/NAS.., SEMJ/NAS..		
SREP..F..	Airframe rod ends – Internal thread rod end with integrated rolling bearing, AS 21153 (inch dimensions), bearing in bearing steel and rod end body in zinc-nickel plated steel with right-hand thread	3.17	334	SUMJ/XRL..	For the cross-reference designation of this legacy product, see SMJ/WAS.., SEMJ/WAS..		
SREP..FL..	Airframe rod ends – Internal thread rod end with integrated rolling bearing, AS 21153 (inch dimensions), bearing in bearing steel and rod end body in zinc-nickel plated steel with left-hand thread	3.17	334	SW..	Airframe spherical plain bearings – Self-lubricating wide, NSA 8135, NSA 8137 (inch dimensions)	2.28	244
SREP..L..	Airframe rod ends – Internal thread rod end with integrated rolling bearing, AS 21153 (inch dimensions), bearing in bearing steel and rod end body in zinc-nickel plated steel with left-hand thread	3.17	334	SW..	For rod ends using this bearing, see R..M.., R..F..		
SREP..M..	Airframe rod ends – External thread rod end with integrated rolling bearing, AS 21151 (inch dimensions), bearing in bearing steel and rod end body in zinc-nickel plated steel with right-hand thread	3.16	332	SWATRCE..	Airframe rolling bearings – Deep groove ball bearing with self-aligning ring single row (metric dimensions), corrosion-resistant-steel bearing and zinc-nickel plated steel self-aligning ring	1.7	64
SREP..ML..	Airframe rod ends – External thread rod end with integrated rolling bearing, AS 21151 (inch dimensions), bearing in bearing steel and rod end body in zinc-nickel plated steel with left-hand thread	3.16	332	SWATRCEI..	Airframe rolling bearings – Deep groove ball bearing with self-aligning ring single row (metric dimensions), corrosion-resistant-steel bearing and zinc-nickel plated steel self-aligning ring	1.8	56
SREP..MR..	Airframe rod ends – External thread rod end with integrated rolling bearing, AS 21151 (inch dimensions), bearing in bearing steel and rod end body in zinc-nickel plated steel with right-hand thread	3.16	332	SWC..M	Airframe rod ends – External thread rod end with integrated rolling bearing (metric dimensions), shielded bearing in corrosion-resistant-steel and rod end body in zinc-nickel plated steel	3.2	298
				SWC..ME	Airframe rod ends – External thread rod end with integrated rolling bearing (metric dimensions), sealed bearing in corrosion-resistant-steel and rod end body in zinc-nickel plated steel	3.2	298
				SWC..MJ..	Airframe rod ends – External thread rod end with integrated rolling bearing (metric dimensions), bearing in corrosion-resistant-steel and rod end body in zinc-nickel plated steel	3.1	296
				SWCN..-..	Airframe rod ends – External thread rod end with integrated rolling bearing (inch dimensions), shielded bearing in corrosion-resistant-steel and rod end body in zinc-nickel plated steel	3.15	326
				SWCN..E..	Airframe rod ends – External thread rod end with integrated rolling bearing (inch dimensions), sealed bearing in corrosion-resistant-steel and rod end body in zinc-nickel plated steel	3.15	326

¹⁾ Starting page of the product table.

Designation	Product	Product table		Designation	Product	Product table	
		No.	Page ¹⁾			No.	Page ¹⁾
SWCN..JESP..	Airframe rod ends – External thread rod end with integrated rolling bearing (inch dimensions), sealed bearing in corrosion-resistant-steel and rod end body in zinc-nickel plated steel with UNJF profile thread	3.14	322	SWRA..M..	Airframe rod ends – External thread rod end with integrated rolling bearing (inch dimensions), bearing in corrosion-resistant-steel and rod end body in zinc-nickel plated steel with right-hand thread	3.16	332
SWCN..JSP..	Airframe rod ends – External thread rod end with integrated rolling bearing (inch dimensions), shielded bearing in corrosion-resistant-steel and rod end body in zinc-nickel plated steel with UNJF profile thread	3.14	322	SWRA..ML..	Airframe rod ends – External thread rod end with integrated rolling bearing (inch dimensions), bearing in corrosion-resistant-steel and rod end body in zinc-nickel plated steel with left-hand thread	3.16	332
SWCN..M	Airframe rod ends – External thread rod end with integrated rolling bearing (metric dimensions), shielded bearing in corrosion-resistant-steel and rod end body in zinc-nickel plated steel	3.2	298	SWRAP..M..	Airframe rod ends – External thread rod end with integrated rolling bearing (inch dimensions), bearing in corrosion-resistant-steel and rod end body in zinc-nickel plated steel with right-hand thread	3.16	332
SWCN..ME	Airframe rod ends – External thread rod end with integrated rolling bearing (metric dimensions), sealed bearing in corrosion-resistant-steel and rod end body in zinc-nickel plated steel	3.2	298	SWRAP..ML..	Airframe rod ends – External thread rod end with integrated rolling bearing (inch dimensions), bearing in corrosion-resistant-steel and rod end body in zinc-nickel plated steel with left-hand thread	3.16	332
SWCN..MESP..	Airframe rod ends – External thread rod end with integrated rolling bearing (inch dimensions), sealed bearing in corrosion-resistant-steel and rod end body in zinc-nickel plated steel with UNF profile thread	3.14	322	SWREP..	Airframe rod ends – Internal thread rod end with integrated rolling bearing (inch dimensions), bearing in corrosion-resistant-steel and rod end body in zinc-nickel plated steel with right-hand thread	3.17	334
SWCN..MESP1	Airframe rod ends – External thread rod end with integrated rolling bearing (metric dimensions), sealed bearing in corrosion-resistant-steel and rod end body in zinc-nickel plated steel	3.2	298	SWREP..F..	Airframe rod ends – Internal thread rod end with integrated rolling bearing (inch dimensions), bearing in corrosion-resistant-steel and rod end body in zinc-nickel plated steel with right-hand thread	3.17	334
SWCN..MJ..	Airframe rod ends – External thread rod end with integrated rolling bearing (metric dimensions), bearing in corrosion-resistant-steel and rod end body in zinc-nickel plated steel	3.1	296	SWREP..FL..	Airframe rod ends – Internal thread rod end with integrated rolling bearing (inch dimensions), bearing in corrosion-resistant-steel and rod end body in zinc-nickel plated steel with left-hand thread	3.17	334
SWCN..MSP..	Airframe rod ends – External thread rod end with integrated rolling bearing (inch dimensions), shielded bearing in corrosion-resistant-steel and rod end body in zinc-nickel plated steel with UNF profile thread	3.14	322	SWREP..L..	Airframe rod ends – Internal thread rod end with integrated rolling bearing (inch dimensions), bearing in corrosion-resistant-steel and rod end body in zinc-nickel plated steel with left-hand thread	3.17	334
SWCN..MSP1	Airframe rod ends – External thread rod end with integrated rolling bearing (metric dimensions), shielded bearing in corrosion-resistant-steel and rod end body in zinc-nickel plated steel	3.2	298	SWREP..M..	Airframe rod ends – External thread rod end with integrated rolling bearing (inch dimensions), bearing in corrosion-resistant-steel and rod end body in zinc-nickel plated steel with right-hand thread	3.16	332
SWEF..	Airframe rod ends – Internal thread integrated metal-to-metal spherical plain bearing rod end (metric dimensions), corrosion-resistant-steel inner ring and zinc-nickel plated steel rod end body	3.8	316	SWREP..ML..	Airframe rod ends – External thread rod end with integrated rolling bearing (inch dimensions), bearing in corrosion-resistant-steel and rod end body in zinc-nickel plated steel with left-hand thread	3.16	332
SWEM..	Airframe rod ends – External thread integrated metal-to-metal spherical plain bearing rod end (metric dimensions), corrosion-resistant-steel inner ring and zinc-nickel plated steel rod end body	3.8	310	SWREP..MR..	Airframe rod ends – External thread rod end with integrated rolling bearing (inch dimensions), bearing in corrosion-resistant-steel and rod end body in zinc-nickel plated steel with right-hand thread	3.16	332
				SZAG..	Airframe rolling bearings – Deep groove ball bearing double row (metric dimensions), zinc-nickel plated bearing steel	1.5	60

¹⁾ Starting page of the product table.

Designation	Product	Product table		Designation	Product	Product table	
		No.	Page ¹⁾			No.	Page ¹⁾
SZAGN..	Airframe rolling bearings – Deep groove ball bearing double row, (metric dimensions), zinc-nickel plated bearing steel	1.6	62	SZGT..	Airframe spherical plain bearings – Metal-to-metal loader slot wide (inch dimensions), bearing steel inner ring and outer ring zinc-plated plated	2.10	184
SZENAS..	Airframe spherical plain bearings – Self-lubricating narrow, AS 14101, AS 14104 (inch dimensions), PH13.8 inner ring and zinc-nickel plated outer ring	2.26	236	SZHMEN..	Airframe spherical plain bearings – Self-lubricating high-misalignment (metric dimensions), zinc-nickel plated	2.21	224
SZENAS..A..	Airframe spherical plain bearings – Self-lubricating narrow, AS 81820/1, AS 81820/4 (inch dimensions), PH13.8 inner ring and zinc-nickel plated outer ring	2.27	240	SZJN..	Airframe rolling bearings – Deep groove ball bearing single row (metric dimensions), zinc-nickel plated bearing steel	1.1	52
SZENE..	Airframe spherical plain bearings – Metal-to-metal swaged narrow (inch dimensions), zinc-nickel plated	2.12	190	SZJNA..	Airframe rolling bearings – Deep groove ball bearing single row (metric dimensions), zinc-nickel plated bearing steel	1.2	54
SZENL..	Airframe spherical plain bearings – Metal-to-metal swaged wide (inch dimensions), zinc-nickel plated	2.14	198	SZK..	Airframe rolling bearings – Spherical roller bearing single row (metric dimensions), zinc-nickel plated bearing steel	1.11	72
SZEWAS..	Airframe spherical plain bearings – Self-lubricating narrow, AS 14102, AS 14103 (inch dimensions), PH13.8 inner ring and zinc-nickel plated outer ring	2.29	248	SZK..D	Airframe rolling bearings – Spherical roller bearing double row (metric dimensions), zinc-nickel plated bearing steel	1.13	76
SZEWAS..A..	Airframe spherical plain bearings – Self-lubricating narrow, AS 81820/2, AS 81820/3 (inch dimensions), PH13.8 inner ring and zinc-nickel plated outer ring	2.30	252	SZK..F	Airframe rolling bearings – Spherical roller bearing single row (metric dimensions), zinc-nickel plated bearing steel	1.11	72
SZGE..	Airframe spherical plain bearings – Metal-to-metal loader slot (metric dimensions), bearing steel inner ring and outer ring zinc-plated plated	2.1	156	SZKN..	Airframe rolling bearings – Self-aligning ball bearing double row, (metric dimensions), zinc-nickel plated bearing steel	1.9	68
SZGL..	Airframe spherical plain bearings – Metal-to-metal loader slot normal (metric dimensions), bearing steel inner ring and outer ring zinc-plated plated	2.2	160	SZKN..	Airframe rolling bearings – Self-aligning ball bearing double row (inch dimensions), zinc-nickel plated bearing steel	1.25	112
SZGLD..	Airframe spherical plain bearings – Metal-to-metal loader slot normal (metric dimensions), bearing steel inner ring and outer ring zinc-plated plated	2.2	160	SZKN..	Airframe rolling bearings – Spherical roller bearing single row (metric dimensions), zinc-nickel plated bearing steel	1.11	72
SZGLS..	Airframe spherical plain bearings – Metal-to-metal loader slot normal (metric dimensions), bearing steel inner ring and outer ring zinc-plated plated	2.2	160	SZKNA..F	Airframe rolling bearings – Spherical roller bearing single row (metric dimensions), zinc-nickel plated bearing steel	1.12	74
SZGLS..MRTG	Airframe spherical plain bearings – Metal-to-metal loader slot normal reinforced (metric dimensions), bearing steel inner ring and outer ring zinc-plated plated with molybdenum disulfide	2.3	164	SZKN..F	Airframe rolling bearings – Spherical roller bearing single row (metric dimensions), zinc-nickel plated bearing steel	1.11	72
SZGLS..RTG	Airframe spherical plain bearings – Metal-to-metal loader slot normal reinforced (metric dimensions), bearing steel inner ring and outer ring zinc-plated plated	2.3	164	SZKNRCE..	Airframe rolling bearings – Self-aligning ball bearing double row (metric dimensions), zinc-nickel plated bearing steel	1.10	70
SZGLS..TAG	Airframe spherical plain bearings – Metal-to-metal loader slot normal (metric dimensions), bearing steel inner ring and outer ring zinc-plated plated	2.2	160	SZLEN..	Airframe spherical plain bearings – Self-lubricating light (metric dimensions), zinc-nickel plated	2.18	214
SZGT..	Airframe spherical plain bearings – Metal-to-metal loader slot wide (metric dimensions), bearing steel inner ring and outer ring zinc-plated plated	2.4	166	SZMWKP..A	Airframe rolling bearings – Deep groove ball bearing single row (inch dimensions), zinc-nickel plated corrosion-resistant-steel, reduced tolerance and SKF super precision	1.15	80
				SZMWKP..B	Airframe rolling bearings – Deep groove ball bearing single row (inch dimensions), zinc-nickel plated corrosion-resistant-steel, reduced tolerance and SKF super precision	1.16	84
				SZNAS..	Airframe spherical plain bearings – Self-lubricating narrow, AS 14101, AS 14104 (inch dimensions), 440C inner ring and zinc-nickel plated outer ring	2.26	236

¹⁾ Starting page of the product table.

Designation	Product	Product table		Designation	Product	Product table	
		No.	Page ¹⁾			No.	Page ¹⁾
SZNAS..A..	Airframe spherical plain bearings – Self-lubricating narrow, AS 81820/1, AS 81820/4 (inch dimensions), 440C inner ring and zinc-nickel plated outer ring	2.27	240	SZQMA..	Airframe spherical plain bearings – Metal-to-metal swaged light (metric dimensions), bronze beryllium inner ring and corrosion-resistant-steel outer ring zinc-nickel plated	2.5	168
SZHEN..	Airframe spherical plain bearings – Self-lubricating narrow (metric dimensions), zinc-nickel plated	2.19	216	SZQME..	Airframe spherical plain bearings – Metal-to-metal swaged narrow (metric dimensions), bronze beryllium inner ring and corrosion-resistant-steel outer ring zinc-nickel plated	2.6	172
SZQ2PL..	Airframe spherical plain bearings – Metal-to-metal swaged split (metric dimensions), bronze beryllium inner ring and corrosion-resistant-steel outer ring zinc-nickel plated	2.9	182	SZQME..	Airframe spherical plain bearings – Metal-to-metal swaged narrow (inch dimensions), bronze beryllium inner ring and corrosion-resistant-steel outer ring zinc-nickel plated	2.11	186
SZQ2PL..	Airframe spherical plain bearings – Metal-to-metal swaged split (inch dimensions), bronze beryllium inner ring and corrosion-resistant-steel outer ring zinc-nickel plated	2.17	210	SZQML..	Airframe spherical plain bearings – Metal-to-metal swaged wide (metric dimensions), bronze beryllium inner ring and corrosion-resistant-steel outer ring zinc-nickel plated	2.7	176
SZQGE..	Airframe spherical plain bearings – Metal-to-metal loader slot (metric dimensions), plated bronze beryllium inner ring and corrosion-resistant-steel outer ring zinc-plated	2.1	156	SZQML..	Airframe spherical plain bearings – Metal-to-metal swaged wide (inch dimensions), bronze beryllium inner ring and corrosion-resistant-steel outer ring zinc-nickel plated	2.13	194
SZQGL..	Airframe spherical plain bearings – Metal-to-metal loader slot normal (metric dimensions), plated bronze beryllium inner ring and corrosion-resistant-steel outer ring zinc-plated	2.2	160	SZQMT..	Airframe spherical plain bearings – Metal-to-metal swaged high misalignment (metric dimensions), bronze beryllium inner ring and corrosion-resistant-steel outer ring zinc-nickel plated	2.8	180
SZQGLD..	Airframe spherical plain bearings – Metal-to-metal loader slot normal (metric dimensions), plated bronze beryllium inner ring and corrosion-resistant-steel outer ring zinc-plated	2.2	160	SZQMT..	Airframe spherical plain bearings – Metal-to-metal swaged high misalignment (inch dimensions), bronze beryllium inner ring and corrosion-resistant-steel outer ring zinc-nickel plated	2.15	202
SZQGLS..	Airframe spherical plain bearings – Metal-to-metal loader slot normal (metric dimensions), plated bronze beryllium inner ring and corrosion-resistant-steel outer ring zinc-plated	2.2	160	SZQXMB..	Airframe spherical plain bearings – Metal-to-metal swaged (inch dimensions), zinc-nickel plated	2.16	206
SZQGLS..MRTG	Airframe spherical plain bearings – Metal-to-metal loader slot normal reinforced (metric dimensions), plated bronze beryllium inner ring and corrosion-resistant-steel outer ring zinc-plated with molybdenum disulfide	2.3	164	SZRL..SP...	For the cross-reference designation of this legacy product, see SZHMEN..		
SZQGLS..RTG	Airframe spherical plain bearings – Metal-to-metal loader slot normal reinforced (metric dimensions), plated bronze beryllium inner ring and corrosion-resistant-steel outer ring zinc-plated	2.3	164	SZT..	Airframe rolling bearings – Deep groove ball bearing single row (metric dimensions), zinc-nickel plated bearing steel	1.3	56
SZQGLS..TAG	Airframe spherical plain bearings – Metal-to-metal loader slot normal (metric dimensions), plated bronze beryllium inner ring and corrosion-resistant-steel outer ring zinc-plated	2.2	160	SZTA..	Airframe rolling bearings – Deep groove ball bearing single row (metric dimensions), zinc-nickel plated bearing steel	1.4	58
SZQGT..	Airframe spherical plain bearings – Metal-to-metal loader slot wide (metric dimensions), plated bronze beryllium inner ring and corrosion-resistant-steel outer ring zinc-plated	2.4	166	SZTRCE..	Airframe rolling bearings – Deep groove ball bearing with self-aligning ring single row EN 3060 (metric dimensions), zinc-nickel plated bearing steel and zinc-nickel plated steel self-aligning ring	1.7	64
SZQGT..	Airframe spherical plain bearings – Metal-to-metal loader slot wide (inch dimensions), plated bronze beryllium inner ring and corrosion-resistant-steel outer ring zinc-plated	2.10	184	SZW2PL..	Airframe spherical plain bearings – Metal-to-metal swaged split (metric dimensions), corrosion-resistant-steel inner ring and outer ring zinc-nickel plated	2.9	182
				SZW2PL..	Airframe spherical plain bearings – Metal-to-metal swaged split (inch dimensions), corrosion-resistant-steel inner ring and outer ring zinc-nickel plated	2.17	210
				SZWAG..	Airframe rolling bearings – Deep groove ball bearing double row (metric dimensions), zinc-nickel plated corrosion-resistant-steel	1.5	60

¹⁾ Starting page of the product table.

Designation	Product	Product table		Designation	Product	Product table	
		No.	Page ¹⁾			No.	Page ¹⁾
SZWAGN..	Airframe rolling bearings – Deep groove ball bearing double row (metric dimensions), zinc-nickel plated corrosion-resistant-steel	1.6	62	SZWGLD..	Airframe spherical plain bearings – Metal-to-metal loader slot normal (metric dimensions), plated corrosion-resistant-steel inner ring and outer ring zinc-plated	2.2	160
SZWAS..	Airframe spherical plain bearings – Self-lubricating narrow, AS 14102, AS 14103 (inch dimensions), 440C inner ring and zinc-nickel plated outer ring	2.29	248	SZWGLS..	Airframe spherical plain bearings – Metal-to-metal loader slot normal (metric dimensions), plated corrosion-resistant-steel inner ring and outer ring zinc-plated	2.2	160
SZWAS..A..	Airframe spherical plain bearings – Self-lubricating narrow, AS 81820/2, AS 81820/3 (inch dimensions), 440C inner ring and zinc-nickel plated outer ring	2.30	252	SZWGLS..MRTG	Airframe spherical plain bearings – Metal-to-metal loader slot normal reinforced (metric dimensions), plated corrosion-resistant-steel inner ring and outer ring zinc-plated with molybdenum disulfide	2.3	164
SZWATA..	Airframe rolling bearings – Deep groove ball bearing single row (metric dimensions), zinc-nickel plated corrosion-resistant-steel	1.4	58	SZWGLS..RTG	Airframe spherical plain bearings – Metal-to-metal loader slot normal reinforced (metric dimensions), plated corrosion-resistant-steel inner ring and outer ring zinc-plated	2.3	164
SZWB5..	Airframe rolling bearings – Deep groove ball bearing single row (inch dimensions), zinc-nickel plated corrosion-resistant-steel, standard tolerance	1.18	92	SZWGLS..TAG	Airframe spherical plain bearings – Metal-to-metal loader slot normal (metric dimensions), plated corrosion-resistant-steel inner ring and outer ring zinc-plated	2.2	160
SZWB55..	Airframe rolling bearings – Deep groove ball bearing double row (inch dimensions), zinc-nickel plated corrosion-resistant-steel	1.19	96	SZWGT..	Airframe spherical plain bearings – Metal-to-metal loader slot wide (metric dimensions), plated corrosion-resistant-steel inner ring and outer ring zinc-plated	2.4	166
SZWDPP..	Airframe rolling bearings – Deep groove ball bearing double row (inch dimensions), zinc-nickel plated corrosion-resistant-steel, standard tolerance	1.20	98	SZWGT..	Airframe spherical plain bearings – Metal-to-metal loader slot wide (inch dimensions), plated corrosion-resistant-steel inner ring and outer ring zinc-plated	2.10	184
SZWDSP..	Airframe rolling bearings – Self-aligning ball bearing double row (inch dimensions), zinc-nickel plated corrosion-resistant-steel, standard tolerance	1.26	114	SZWJN..	Airframe rolling bearings – Deep groove ball bearing single row (metric dimensions), zinc-nickel plated corrosion-resistant-steel	1.1	52
SZWDSP..	Airframe rolling bearings – Spherical roller bearing single row (inch dimensions), zinc-nickel plated corrosion-resistant-steel	1.27	116	SZWJNA..	Airframe rolling bearings – Deep groove ball bearing single row (metric dimensions), zinc-nickel plated corrosion-resistant-steel	1.2	54
SZWDW..	Airframe rolling bearings – Deep groove ball bearing double row (inch dimensions), zinc-nickel plated corrosion-resistant-steel, standard tolerance	1.21	100	SZWK..	Airframe rolling bearings – Spherical roller bearing single row (metric dimensions), zinc-nickel plated corrosion-resistant-steel	1.11	72
SZWDW..K	Airframe rolling bearings – Deep groove ball bearing double row (inch dimensions), zinc-nickel plated corrosion-resistant-steel, standard tolerance	1.21	100	SZWK..D	Airframe rolling bearings – Spherical roller bearing double row (metric dimensions), zinc-nickel plated corrosion-resistant-steel	1.13	76
SZWDW..K2	Airframe rolling bearings – Deep groove ball bearing double row (inch dimensions), zinc-nickel plated corrosion-resistant-steel, standard tolerance	1.21	100	SZWK..F	Airframe rolling bearings – Spherical roller bearing single row (metric dimensions), zinc-nickel plated corrosion-resistant-steel	1.11	72
SZWEN..	Airframe spherical plain bearings – Self-lubricating wide (metric dimensions), zinc-nickel plated	2.20	220	SZWKN..	Airframe rolling bearings – Self-aligning ball bearing double row (metric dimensions), zinc-nickel plated corrosion-resistant-steel	1.9	68
SZWGE..	Airframe spherical plain bearings – Metal-to-metal loader slot (metric dimensions), plated corrosion-resistant-steel inner ring and outer ring zinc-plated	2.1	156	SZWKN..	Airframe rolling bearings – Self-aligning ball bearing double row (inch dimensions), cadmium plated corrosion-resistant-steel	1.25	112
SZWGL..	Airframe spherical plain bearings – Metal-to-metal loader slot normal (metric dimensions), plated corrosion-resistant-steel inner ring and outer ring zinc-plated	2.2	160	SZWKN..	Airframe rolling bearings – Spherical roller bearing single row (metric dimensions), zinc-nickel plated corrosion-resistant-steel	1.11	72

¹⁾ Starting page of the product table.

Designation	Product	Product table		Designation	Product	Product table	
		No.	Page ¹⁾			No.	Page ¹⁾
SZWKNA..F	Airframe rolling bearings – Spherical roller bearing single row (metric dimensions), zinc-nickel plated corrosion-resistant-steel	1.12	74	SZWKSP..A	Airframe rolling bearings – Self-aligning ball bearing single row (inch dimensions), zinc-nickel plated corrosion-resistant-steel, standard tolerance	1.23	106
SZWKNA..F	Airframe rolling bearings – Spherical roller bearing single row (metric dimensions), zinc-nickel plated corrosion-resistant-steel	1.11	72	SZWKSP..APSP..	Airframe rolling bearings – Self-aligning ball bearing single row (inch dimensions), zinc-nickel plated corrosion-resistant-steel, shielded	1.24	110
SZWKNRCE..	Airframe rolling bearings – Self-aligning ball bearing double row (metric dimensions), zinc-nickel plated corrosion-resistant-steel	1.10	70	SZWKSP..ASP..	Airframe rolling bearings – Self-aligning ball bearing single row (inch dimensions), zinc-nickel plated corrosion-resistant-steel, sealed	1.24	110
SZWKP..	Airframe rolling bearings – Deep groove ball bearing single row (inch dimensions), zinc-nickel plated corrosion-resistant-steel, standard tolerance	1.14	78	SZWKSP..L	Airframe rolling bearings – Self-aligning ball bearing single row (inch dimensions), zinc-nickel plated corrosion-resistant-steel, standard tolerance	1.23	106
SZWKP..A	Airframe rolling bearings – Deep groove ball bearing single row (inch dimensions), zinc-nickel plated corrosion-resistant-steel, standard tolerance	1.15	80	SZWKSP..PSP..	Airframe rolling bearings – Self-aligning ball bearing single row (inch dimensions), zinc-nickel plated corrosion-resistant-steel, shielded	1.24	110
SZWKP..APSP..	Airframe rolling bearings – Deep groove ball bearing single row (inch dimensions), cadmium plated corrosion-resistant-steel, shielded	1.17	90	SZWKSP..SP..	Airframe rolling bearings – Self-aligning ball bearing single row (inch dimensions), zinc-nickel plated corrosion-resistant-steel, sealed	1.24	110
SZWKP..ASP..	Airframe rolling bearings – Deep groove ball bearing single row (inch dimensions), cadmium plated corrosion-resistant-steel, sealed	1.17	90	SZWMA..	Airframe spherical plain bearings – Metal-to-metal swaged light (metric dimensions), corrosion-resistant-steel inner ring and outer ring zinc-nickel plated	2.5	168
SZWKP..B	Airframe rolling bearings – Deep groove ball bearing single row (inch dimensions), zinc-nickel plated corrosion-resistant-steel, standard tolerance	1.16	84	SZWMB5..	Airframe rolling bearings – Deep groove ball bearing single row (inch dimensions), zinc-nickel plated corrosion-resistant-steel, reduced clearance and precision	1.18	92
SZWKP..BS	Airframe rolling bearings – Deep groove ball bearing with self-aligning ring single row (inch dimensions), zinc-nickel plated corrosion-resistant-steel, standard tolerance	1.22	102	SZWMDDPP..	Airframe rolling bearings – Deep groove ball bearing double row (inch dimensions), zinc-nickel plated corrosion-resistant-steel, reduced tolerance and SKF super precision	1.20	98
SZWKP..L	Airframe rolling bearings – Deep groove ball bearing single row (inch dimensions), zinc-nickel plated corrosion-resistant-steel, standard tolerance	1.14	78	SZWMDDSP..	Airframe rolling bearings – Self-aligning ball bearing double row (inch dimensions), zinc-nickel plated corrosion-resistant-steel, reduced tolerance and SKF super precision	1.26	114
SZWKP..LPSP..	Airframe rolling bearings – Deep groove ball bearing single row (inch dimensions), cadmium plated corrosion-resistant-steel, shielded	1.17	90	SZWMDW..	Airframe rolling bearings – Deep groove ball bearing double row (inch dimensions), zinc-nickel plated corrosion-resistant-steel, reduced tolerance and SKF super precision	1.21	100
SZWKP..LSP..	Airframe rolling bearings – Deep groove ball bearing single row (inch dimensions), cadmium plated corrosion-resistant-steel, sealed	1.17	90	SZWMDW..K	Airframe rolling bearings – Deep groove ball bearing double row (inch dimensions), zinc-nickel plated corrosion-resistant-steel, reduced tolerance and SKF super precision	1.21	100
SZWKP..PSP..	Airframe rolling bearings – Deep groove ball bearing single row (inch dimensions), cadmium plated corrosion-resistant-steel, shielded	1.17	90	SZWMDW..K2	Airframe rolling bearings – Deep groove ball bearing double row (inch dimensions), zinc-nickel plated corrosion-resistant-steel, reduced tolerance and SKF super precision	1.21	100
SZWKP..SP..	Airframe rolling bearings – Deep groove ball bearing single row (inch dimensions), cadmium plated corrosion-resistant-steel, sealed	1.17	90				
SZWKSP..	Airframe rolling bearings – Self-aligning ball bearing single row (inch dimensions), zinc-nickel plated corrosion-resistant-steel, standard tolerance	1.23	106				

¹⁾ Starting page of the product table.

Designation	Product	Product table		Designation	Product	Product table	
		No.	Page ¹⁾			No.	Page ¹⁾
SZWME..	Airframe spherical plain bearings – Metal-to-metal swaged narrow (metric dimensions), corrosion-resistant-steel inner ring and outer ring zinc-nickel plated	2.6	172	SZWQ2PL..	Airframe spherical plain bearings – Metal-to-metal swaged split (metric dimensions), corrosion-resistant-steel inner ring and bronze aluminium outer ring zinc-nickel plated	2.9	182
SZWME..	Airframe spherical plain bearings – Metal-to-metal swaged narrow, AS 21154, AS 21155 (inch dimensions), corrosion-resistant-steel inner ring and outer ring zinc-nickel plated	2.11	186	SZWQ2PL..	Airframe spherical plain bearings – Metal-to-metal swaged split (inch dimensions), corrosion-resistant-steel inner ring and bronze aluminium outer ring zinc-nickel plated	2.17	210
SZWMKP..	Airframe rolling bearings – Deep groove ball bearing single row (inch dimensions), zinc-nickel plated corrosion-resistant-steel, reduced tolerance and SKF super precision	1.14	78	SZWMKP..	Airframe spherical plain bearings – Metal-to-metal swaged light (metric dimensions), corrosion-resistant-steel inner ring and bronze aluminium outer ring zinc-nickel plated	2.5	168
SZWMKP..BS	Airframe rolling bearings – Deep groove ball bearing with self-aligning ring single row (inch dimensions), zinc-nickel plated corrosion-resistant-steel, reduced tolerance and SKF super precision	1.22	102	SZWMKP..	Airframe spherical plain bearings – Metal-to-metal swaged narrow (metric dimensions), corrosion-resistant-steel inner ring and bronze aluminium outer ring zinc-nickel plated	2.6	172
SZWMKP..L	Airframe rolling bearings – Deep groove ball bearing single row (inch dimensions), zinc-nickel plated corrosion-resistant-steel, reduced tolerance and SKF super precision	1.14	78	SZWMKP..L	Airframe spherical plain bearings – Metal-to-metal swaged narrow, AS 21154, AS 21155 (inch dimensions), corrosion-resistant-steel inner ring and bronze aluminium outer ring zinc-nickel plated	2.11	186
SZWMKP..	Airframe rolling bearings – Self-aligning ball bearing single row (inch dimensions), zinc-nickel plated corrosion-resistant-steel, reduced tolerance and SKF super precision	1.23	106	SZWMKP..	Airframe spherical plain bearings – Metal-to-metal swaged wide (metric dimensions), corrosion-resistant-steel inner ring and bronze aluminium outer ring zinc-nickel plated	2.7	176
SZWMKP..A	Airframe rolling bearings – Self-aligning ball bearing single row (inch dimensions), zinc-nickel plated corrosion-resistant-steel, reduced tolerance and SKF super precision	1.23	106	SZWMKP..A	Airframe spherical plain bearings – Metal-to-metal swaged wide (inch dimensions), corrosion-resistant-steel inner ring and bronze aluminium outer ring zinc-nickel plated	2.13	194
SZWMKP..L	Airframe rolling bearings – Self-aligning ball bearing single row (inch dimensions), zinc-nickel plated corrosion-resistant-steel, reduced tolerance and SKF super precision	1.23	106	SZWMKP..L	Airframe spherical plain bearings – Metal-to-metal swaged wide (inch dimensions), corrosion-resistant-steel inner ring and bronze aluminium outer ring zinc-nickel plated	2.8	180
SZWML..	Airframe spherical plain bearings – Metal-to-metal swaged wide (metric dimensions), corrosion-resistant-steel inner ring and outer ring zinc-nickel plated	2.7	176	SZWML..	Airframe spherical plain bearings – Metal-to-metal swaged high misalignment (metric dimensions), corrosion-resistant-steel inner ring and bronze aluminium outer ring zinc-nickel plated	2.15	202
SZWML..	Airframe spherical plain bearings – Metal-to-metal swaged wide (inch dimensions), corrosion-resistant-steel inner ring and outer ring zinc-nickel plated	2.13	194	SZWML..	Airframe spherical plain bearings – Metal-to-metal swaged high misalignment (inch dimensions), corrosion-resistant-steel inner ring and bronze aluminium outer ring zinc-nickel plated	2.15	202
SZWMT..	Airframe spherical plain bearings – Metal-to-metal swaged high misalignment (metric dimensions), corrosion-resistant-steel inner ring and outer ring zinc-nickel plated	2.8	180	SZWT..	Airframe rolling bearings – Deep groove ball bearing single row (metric dimensions), zinc-nickel plated corrosion-resistant-steel	1.3	56
SZWMT..	Airframe spherical plain bearings – Metal-to-metal swaged high misalignment (inch dimensions), corrosion-resistant-steel inner ring and outer ring zinc-nickel plated	2.15	202	SZXC..M	Airframe rod ends – External thread rod end with integrated rolling bearing (metric dimensions), shielded bearing in corrosion-resistant-steel and rod end body in zinc-nickel plated corrosion-resistant-steel	3.2	298

¹⁾ Starting page of the product table.

Designation	Product	Product table		Designation	Product	Product table	
		No.	Page ¹⁾			No.	Page ¹⁾
SZXC..ME	Airframe rod ends – External thread rod end with integrated rolling bearing (metric dimensions), sealed bearing in corrosion-resistant-steel and rod end body in zinc-nickel plated corrosion-resistant-steel	3.2	298	SZXCN..MSP..	Airframe rod ends – External thread rod end with integrated rolling bearing (inch dimensions), shielded bearing in corrosion-resistant-steel and rod end body in zinc-nickel plated corrosion-resistant-steel with UNF profile thread	3.14	322
SZXC..MJ..	Airframe rod ends – External thread rod end with integrated rolling bearing (metric dimensions), bearing in corrosion-resistant-steel and rod end body in zinc-nickel plated corrosion-resistant-steel	3.1	296	SZXCN..MSP1	Airframe rod ends – External thread rod end with integrated rolling bearing (metric dimensions), shielded bearing in corrosion-resistant-steel and rod end body in zinc-nickel plated corrosion-resistant-steel	3.2	298
SZXCN..-..	Airframe rod ends – External thread rod end with integrated rolling bearing (inch dimensions), shielded bearing in corrosion-resistant-steel and rod end body in zinc-nickel plated corrosion-resistant-steel	3.15	326	SZXR..	For the cross-reference designation of this legacy product, see SZLEN..		
SZXCN..E..	Airframe rod ends – External thread rod end with integrated rolling bearing (inch dimensions), sealed bearing in corrosion-resistant-steel and rod end body in zinc-nickel plated corrosion-resistant-steel	3.15	326	SZXR..	For the cross-reference designation of this legacy product, see SZLEN.., SZNAS..		
SZXCN..JESP..	Airframe rod ends – External thread rod end with integrated rolling bearing (inch dimensions), sealed bearing in corrosion-resistant-steel and rod end body in zinc-nickel plated corrosion-resistant-steel with UNJF profile thread	3.14	322	SZXR..A..	For the cross-reference designation of this legacy product, see SZNAS..A..		
SZXCN..JSP..	Airframe rod ends – External thread rod end with integrated rolling bearing (inch dimensions), shielded bearing in corrosion-resistant-steel and rod end body in zinc-nickel plated corrosion-resistant-steel with UNJF profile thread	3.14	322	SZXR..	For the cross-reference designation of this legacy product, see SZWEN.., SZWAS..		
SZXCN..M	Airframe rod ends – External thread rod end with integrated rolling bearing (metric dimensions), shielded bearing in corrosion-resistant-steel and rod end body in zinc-nickel plated corrosion-resistant-steel	3.2	298	SZXR..A..	For the cross-reference designation of this legacy product, see SZWAS..A..		
SZXCN..ME	Airframe rod ends – External thread rod end with integrated rolling bearing (metric dimensions), sealed bearing in corrosion-resistant-steel and rod end body in zinc-nickel plated corrosion-resistant-steel	3.2	298	SZXR..FR..	Airframe spherical plain bearings – Self-lubricating pre-staked (metric dimensions), zinc-nickel plated	2.23	228
SZXCN..MESP..	Airframe rod ends – External thread rod end with integrated rolling bearing (inch dimensions), sealed bearing in corrosion-resistant-steel and rod end body in zinc-nickel plated corrosion-resistant-steel with UNF profile thread	3.14	322	SZXR..	Airframe spherical plain bearings – Self-lubricating high-misalignment (metric dimensions), zinc-nickel plated	2.22	226
SZXCN..MESP1	Airframe rod ends – External thread rod end with integrated rolling bearing (metric dimensions), sealed bearing in corrosion-resistant-steel and rod end body in zinc-nickel plated corrosion-resistant-steel	3.2	298	SZXR..	Airframe spherical plain bearings – Self-lubricating high-misalignment (inch dimensions), zinc-nickel plated	2.33	260
SZXCN..MJ..	Airframe rod ends – External thread rod end with integrated rolling bearing (metric dimensions), bearing in corrosion-resistant-steel and rod end body in zinc-nickel plated corrosion-resistant-steel	3.1	296	T..	Airframe rolling bearings – Deep groove ball bearing single row (metric dimensions), not plated bearing steel	1.3	56
				TA..	Airframe rolling bearings – Deep groove ball bearing single row, EN 3281 (metric dimensions), not plated bearing steel	1.4	58
				TEFJ/QML..	Airframe rod ends – Internal thread inserted wide metal-to-metal spherical plain bearing rod end (metric dimensions), anodized titanium rod end body, bronze beryllium inner ring and corrosion-resistant-steel outer ring	3.12	318
				TEFJ/QML..	For the bearing used in this rod end, see QML..		
				TEFJ/QMLC..R	Airframe rod ends – Internal thread inserted wide metal-to-metal spherical plain bearing rod end (inch dimensions), anodized titanium rod end body, bronze beryllium inner ring and corrosion-resistant-steel outer ring with lubrication by the rod end body	3.34	378
				TEFJ/QMLC..R	For the bearing used in this rod end, see QML..		
				TEFJ/QML..R	Airframe rod ends – Internal thread inserted wide metal-to-metal spherical plain bearing rod end (inch dimensions), anodized titanium rod end body, bronze beryllium inner ring and corrosion-resistant-steel outer ring without lubrication groove	3.34	378

¹⁾ Starting page of the product table.

Designation	Product	Product table No.	Page ¹⁾	Designation	Product	Product table No.	Page ¹⁾
TEFJ/QML..R	For the bearing used in this rod end, see QML..			TEFJ/RT..	For the bearing used in this rod end, see XRT..		
TEFJ/QMLS..R	Airframe rod ends – Internal thread inserted wide metal-to-metal spherical plain bearing rod end (inch dimensions), anodized titanium rod end body, bronze beryllium inner ring and corrosion-resistant-steel outer ring with lubrication by the inner ring For the bearing used in this rod end, see QML..	3.34	378	TEFJ/RT..R..	Airframe rod ends – Internal thread inserted high-misalignment self-lubricating spherical plain bearing rod end (inch dimensions), anodized titanium rod end	3.31	372
TEFJ/QMLS..R	For the bearing used in this rod end, see QML..			TEFJ/RT..R..	For the bearing used in this rod end, see XRT..		
TEFJ/QMT..	Airframe rod ends – Internal thread inserted high misalignment metal-to-metal spherical plain bearing rod end (metric dimensions), anodized titanium rod end body, bronze beryllium inner ring and corrosion-resistant-steel outer ring	3.13	320	TEFJ/WML..	Airframe rod ends – Internal thread inserted wide metal-to-metal spherical plain bearing rod end (metric dimensions), anodized titanium rod end body, corrosion-resistant-steel inner ring and corrosion-resistant-steel outer ring	3.12	318
TEFJ/QMT..	For the bearing used in this rod end, see QMT..			TEFJ/WML..	For the bearing used in this rod end, see WML..		
TEFJ/QMTC..R	Airframe rod ends – Internal thread inserted high misalignment metal-to-metal spherical plain bearing rod end (inch dimensions), anodized titanium rod end body, bronze beryllium inner ring and corrosion-resistant-steel outer ring with lubrication by the rod end body	3.35	380	TEFJ/WMLC..R	Airframe rod ends – Internal thread inserted wide metal-to-metal spherical plain bearing rod end (inch dimensions), anodized titanium rod end body, corrosion-resistant-steel inner ring and corrosion-resistant-steel outer ring with lubrication by the rod end body	3.34	378
TEFJ/QMTC..R	For the bearing used in this rod end, see QMT..			TEFJ/WMLC..R	For the bearing used in this rod end, see WML..		
TEFJ/QMT..R	Airframe rod ends – Internal thread inserted high misalignment metal-to-metal spherical plain bearing rod end (inch dimensions), anodized titanium rod end body, bronze beryllium inner ring and corrosion-resistant-steel outer ring without lubrication groove	3.35	380	TEFJ/WML..R	Airframe rod ends – Internal thread inserted wide metal-to-metal spherical plain bearing rod end (inch dimensions), anodized titanium rod end body, corrosion-resistant-steel inner ring and corrosion-resistant-steel outer ring without lubrication groove	3.34	378
TEFJ/QMT..R	For the bearing used in this rod end, see QMT..			TEFJ/WML..R	For the bearing used in this rod end, see WML..		
TEFJ/QMTS..R	Airframe rod ends – Internal thread inserted high misalignment metal-to-metal spherical plain bearing rod end (inch dimensions), anodized titanium rod end body, bronze beryllium inner ring and corrosion-resistant-steel outer ring with lubrication by the inner ring	3.35	380	TEFJ/WMLS..R	Airframe rod ends – Internal thread inserted wide metal-to-metal spherical plain bearing rod end (inch dimensions), anodized titanium rod end body, corrosion-resistant-steel inner ring and corrosion-resistant-steel outer ring with lubrication by the inner ring	3.34	378
TEFJ/QMTS..R	For the bearing used in this rod end, see QMT..			TEFJ/WMLS..R	For the bearing used in this rod end, see WML..		
TEFJ/RL..	Airframe rod ends – Internal thread inserted wide self-lubricating spherical plain bearing rod end (metric dimensions), anodized titanium rod end	3.6	306	TEFJ/WMT..	Airframe rod ends – Internal thread inserted high misalignment metal-to-metal spherical plain bearing rod end (metric dimensions), anodized titanium rod end body, corrosion-resistant-steel inner ring and corrosion-resistant-steel outer ring	3.13	320
TEFJ/RL..	For the bearing used in this rod end, see WEN..			TEFJ/WMT..	For the bearing used in this rod end, see WMT..		
TEFJ/RL..R..	Airframe rod ends – Internal thread inserted wide self-lubricating spherical plain bearing rod end (inch dimensions), anodized titanium rod end	3.30	370	TEFJ/WMTC..R	Airframe rod ends – Internal thread inserted high misalignment metal-to-metal spherical plain bearing rod end (inch dimensions), anodized titanium rod end body, corrosion-resistant-steel inner ring and corrosion-resistant-steel outer ring with lubrication by the rod end body	3.35	380
TEFJ/RL..R..	For the bearing used in this rod end, see WAS..			TEFJ/WMTC..R	For the bearing used in this rod end, see WMT..		
TEFJ/RT..	Airframe rod ends – Internal thread inserted high-misalignment self-lubricating spherical plain bearing rod end (metric dimensions), anodized titanium rod end	3.7	308				

¹⁾ Starting page of the product table.

Designation	Product	Product table		Designation	Product	Product table	
		No.	Page ¹⁾			No.	Page ¹⁾
TEFJ/WMT..R	Airframe rod ends – Internal thread inserted high misalignment metal-to-metal spherical plain bearing rod end (inch dimensions), anodized titanium rod end body, corrosion-resistant-steel inner ring and corrosion-resistant-steel outer ring without lubrication groove	3.35	380	TEFJ/WQMT..R	Airframe rod ends – Internal thread inserted high misalignment metal-to-metal spherical plain bearing rod end (inch dimensions), anodized titanium rod end body, corrosion-resistant-steel inner ring and bronze aluminium outer ring with lubrication by the rod end body	3.35	380
TEFJ/WMT..R	For the bearing used in this rod end, see WMT..			TEFJ/WQMT..R	For the bearing used in this rod end, see WQMT..		
TEFJ/WMTS..R	Airframe rod ends – Internal thread inserted high misalignment metal-to-metal spherical plain bearing rod end (inch dimensions), anodized titanium rod end body, corrosion-resistant-steel inner ring and corrosion-resistant-steel outer ring with lubrication by the inner ring	3.35	380	TEFJ/WQMT..R	For the bearing used in this rod end, see WMT..		
TEFJ/WMTS..R	For the bearing used in this rod end, see WMT..			TEFJ/WQMTS..R	Airframe rod ends – Internal thread inserted high misalignment metal-to-metal spherical plain bearing rod end (inch dimensions), anodized titanium rod end body, corrosion-resistant-steel inner ring and bronze aluminium outer ring with lubrication by the inner ring	3.35	380
TEFJ/WQML..	Airframe rod ends – Internal thread inserted wide metal-to-metal spherical plain bearing rod end (metric dimensions), anodized titanium rod end body, corrosion-resistant-steel inner ring and bronze aluminium outer ring	3.12	318	TEFJ/WQMTS..R	For the bearing used in this rod end, see WQMT..		
TEFJ/WQML..	For the bearing used in this rod end, see WQML..			TEMA..	Airframe rod ends – External thread inserted self-lubricating spherical plain bearing rod end (metric dimensions), anodized titanium rod end	3.3	300
TEFJ/WQMLC..R	Airframe rod ends – Internal thread inserted wide metal-to-metal spherical plain bearing rod end (inch dimensions), anodized titanium rod end body, corrosion-resistant-steel inner ring and bronze aluminium outer ring with lubrication by the rod end body	3.34	378	TEMA..	For the bearing used in this rod end, see HMEN..R..		
TEFJ/WQMLC..R	For the bearing used in this rod end, see WQML..			TEMJ/QML..	Airframe rod ends – External thread inserted wide metal-to-metal spherical plain bearing rod end (metric dimensions), anodized titanium rod end body, bronze beryllium inner ring and corrosion-resistant-steel outer ring	3.9	312
TEFJ/WQML..R	Airframe rod ends – Internal thread inserted wide metal-to-metal spherical plain bearing rod end (inch dimensions), anodized titanium rod end body, corrosion-resistant-steel inner ring and bronze aluminium outer ring without lubrication groove	3.34	378	TEMJ/QML..	For the bearing used in this rod end, see QML..		
TEFJ/WQML..R	For the bearing used in this rod end, see WQML..			TEMJ/QMLC..R	Airframe rod ends – External thread inserted wide metal-to-metal spherical plain bearing rod end (inch dimensions), anodized titanium rod end body, bronze beryllium inner ring and corrosion-resistant-steel outer ring with lubrication by the rod end body	3.32	374
TEFJ/WQMLS..R	Airframe rod ends – Internal thread inserted wide metal-to-metal spherical plain bearing rod end (inch dimensions), anodized titanium rod end body, corrosion-resistant-steel inner ring and bronze aluminium outer ring with lubrication by the inner ring	3.34	378	TEMJ/QMLC..R	For the bearing used in this rod end, see QML..		
TEFJ/WQMLS..R	For the bearing used in this rod end, see WQML..			TEMJ/QML..R	Airframe rod ends – External thread inserted wide metal-to-metal spherical plain bearing rod end (inch dimensions), anodized titanium rod end body, bronze beryllium inner ring and corrosion-resistant-steel outer ring without lubrication groove	3.32	374
TEFJ/WQMT..	Airframe rod ends – Internal thread inserted high misalignment metal-to-metal spherical plain bearing rod end (metric dimensions), anodized titanium rod end body, corrosion-resistant-steel inner ring and bronze aluminium outer ring	3.13	320	TEMJ/QML..R	For the bearing used in this rod end, see QML..		
TEFJ/WQMT..	For the bearing used in this rod end, see WQMT..						

¹⁾ Starting page of the product table.

Designation	Product	Product table		Designation	Product	Product table	
		No.	Page ¹⁾			No.	Page ¹⁾
TEMJ/QMLS..R	Airframe rod ends – External thread inserted wide metal-to-metal spherical plain bearing rod end (inch dimensions), anodized titanium rod end body, bronze beryllium inner ring and corrosion-resistant-steel outer ring with lubrication by the inner ring	3.32	374	TEMJ/RT..R..	Airframe rod ends – External thread inserted high-misalignment self-lubricating spherical plain bearing rod end (inch dimensions), anodized titanium rod end	3.24	348
TEMJ/QMLS..R	For the bearing used in this rod end, see QML..			TEMJ/RT..R..	For the bearing used in this rod end, see XRT..		
TEMJ/QMT..	Airframe rod ends – External thread inserted high misalignment metal-to-metal spherical plain bearing rod end (metric dimensions), anodized titanium rod end body, bronze beryllium inner ring and corrosion-resistant-steel outer ring	3.10	314	TEMJ/WML..	Airframe rod ends – External thread inserted wide metal-to-metal spherical plain bearing rod end (metric dimensions), anodized titanium rod end body, corrosion-resistant-steel inner ring and corrosion-resistant-steel outer ring	3.9	312
TEMJ/QMT..	For the bearing used in this rod end, see QMT..			TEMJ/WML..	For the bearing used in this rod end, see WML..		
TEMJ/QMTC..R	Airframe rod ends – External thread inserted high misalignment metal-to-metal spherical plain bearing rod end (inch dimensions), anodized titanium rod end body, bronze beryllium inner ring and corrosion-resistant-steel outer ring with lubrication by the rod end body	3.33	300	TEMJ/WMLC..R	Airframe rod ends – External thread inserted wide metal-to-metal spherical plain bearing rod end (inch dimensions), anodized titanium rod end body, corrosion-resistant-steel inner ring and corrosion-resistant-steel outer ring with lubrication by the rod end body	3.32	374
TEMJ/QMTC..R	For the bearing used in this rod end, see QMT..			TEMJ/WMLC..R	For the bearing used in this rod end, see WML..		
TEMJ/QMT..R	Airframe rod ends – External thread inserted high misalignment metal-to-metal spherical plain bearing rod end (inch dimensions), anodized titanium rod end body, bronze beryllium inner ring and corrosion-resistant-steel outer ring without lubrication groove	3.33	300	TEMJ/WML..R	Airframe rod ends – External thread inserted wide metal-to-metal spherical plain bearing rod end (inch dimensions), anodized titanium rod end body, corrosion-resistant-steel inner ring and corrosion-resistant-steel outer ring without lubrication groove	3.32	374
TEMJ/QMT..R	For the bearing used in this rod end, see QMT..			TEMJ/WML..R	For the bearing used in this rod end, see WML..		
TEMJ/QMTC..R	Airframe rod ends – External thread inserted high misalignment metal-to-metal spherical plain bearing rod end (inch dimensions), anodized titanium rod end body, bronze beryllium inner ring and corrosion-resistant-steel outer ring with lubrication by the inner ring	3.33	300	TEMJ/WMLC..R	Airframe rod ends – External thread inserted wide metal-to-metal spherical plain bearing rod end (inch dimensions), anodized titanium rod end body, corrosion-resistant-steel inner ring and corrosion-resistant-steel outer ring with lubrication by the inner ring	3.32	374
TEMJ/QMT..R	For the bearing used in this rod end, see QMT..			TEMJ/WMLC..R	For the bearing used in this rod end, see WML..		
TEMJ/QMTC..R	Airframe rod ends – External thread inserted high misalignment metal-to-metal spherical plain bearing rod end (inch dimensions), anodized titanium rod end body, bronze beryllium inner ring and corrosion-resistant-steel outer ring with lubrication by the inner ring	3.33	300	TEMJ/WMLS..R	Airframe rod ends – External thread inserted wide metal-to-metal spherical plain bearing rod end (inch dimensions), anodized titanium rod end body, corrosion-resistant-steel inner ring and corrosion-resistant-steel outer ring with lubrication by the inner ring	3.32	374
TEMJ/QMT..R	For the bearing used in this rod end, see QMT..			TEMJ/WMLS..R	For the bearing used in this rod end, see WML..		
TEMJ/QMTC..R	Airframe rod ends – External thread inserted high misalignment metal-to-metal spherical plain bearing rod end (metric dimensions), anodized titanium rod end body, corrosion-resistant-steel inner ring and corrosion-resistant-steel outer ring	3.10	314	TEMJ/WMT..	Airframe rod ends – External thread inserted high misalignment metal-to-metal spherical plain bearing rod end (metric dimensions), anodized titanium rod end body, corrosion-resistant-steel inner ring and corrosion-resistant-steel outer ring	3.10	314
TEMJ/RL..	For the bearing used in this rod end, see QMT..			TEMJ/WMT..	For the bearing used in this rod end, see WMT..		
TEMJ/RL..	Airframe rod ends – External thread inserted wide self-lubricating spherical plain bearing rod end (metric dimensions), anodized titanium rod end	3.4	302	TEMJ/WMTC..R	Airframe rod ends – External thread inserted high misalignment metal-to-metal spherical plain bearing rod end (inch dimensions), anodized titanium rod end body, corrosion-resistant-steel inner ring and corrosion-resistant-steel outer ring with lubrication by the rod end body	3.33	300
TEMJ/RL..	For the bearing used in this rod end, see WEN..			TEMJ/WMTC..R	For the bearing used in this rod end, see WMT..		
TEMJ/RL..R..	Airframe rod ends – External thread inserted wide self-lubricating spherical plain bearing rod end (inch dimensions), anodized titanium rod end	3.23	346	TEMJ/WMTC..R	Airframe rod ends – External thread inserted high misalignment metal-to-metal spherical plain bearing rod end (inch dimensions), anodized titanium rod end body, corrosion-resistant-steel inner ring and corrosion-resistant-steel outer ring with lubrication by the rod end body	3.33	300
TEMJ/RL..R..	For the bearing used in this rod end, see WAS..			TEMJ/WMTC..R	For the bearing used in this rod end, see WMT..		
TEMJ/RT..	Airframe rod ends – External thread inserted high-misalignment self-lubricating spherical plain bearing rod end (metric dimensions), anodized titanium rod end	3.5	346				
TEMJ/RT..	For the bearing used in this rod end, see XRT..						

¹⁾ Starting page of the product table.

Designation	Product	Product table		Designation	Product	Product table	
		No.	Page ¹⁾			No.	Page ¹⁾
TEMJ/WMT..R	Airframe rod ends – External thread inserted high misalignment metal-to-metal spherical plain bearing rod end (inch dimensions), anodized titanium rod end body, corrosion-resistant-steel inner ring and corrosion-resistant-steel outer ring without lubrication groove	3.33	300	TEMJ/WQMT..R	Airframe rod ends – External thread inserted high misalignment metal-to-metal spherical plain bearing rod end (inch dimensions), anodized titanium rod end body, corrosion-resistant-steel inner ring and bronze aluminium outer ring with lubrication by the rod end body	3.33	300
TEMJ/WMT..R	For the bearing used in this rod end, see WMT..			TEMJ/WQMT..R	For the bearing used in this rod end, see WQMT..		
TEMJ/WMTS..R	Airframe rod ends – External thread inserted high misalignment metal-to-metal spherical plain bearing rod end (inch dimensions), anodized titanium rod end body, corrosion-resistant-steel inner ring and corrosion-resistant-steel outer ring with lubrication by the inner ring	3.33	300	TEMJ/WQMT..R	For the bearing used in this rod end, see WMT..		
TEMJ/WMTS..R	For the bearing used in this rod end, see WMT..			TEMJ/WQMTS..R	Airframe rod ends – External thread inserted high misalignment metal-to-metal spherical plain bearing rod end (inch dimensions), anodized titanium rod end body, corrosion-resistant-steel inner ring and bronze aluminium outer ring with lubrication by the inner ring	3.33	300
TEMJ/WQML..	Airframe rod ends – External thread inserted wide metal-to-metal spherical plain bearing rod end (metric dimensions), anodized titanium rod end body, corrosion-resistant-steel inner ring and bronze aluminium outer ring	3.9	312	TEMJ/WQMTS..R	For the bearing used in this rod end, see WQMT..		
TEMJ/WQML..	For the bearing used in this rod end, see WQML..			TRCE..	Airframe rolling bearings – Deep groove ball bearing with self-aligning ring single row, EN 3059 (metric dimensions), bearing steel bearing and cadmium plated steel self-aligning ring	1.7	64
TEMJ/WQMLC..R	Airframe rod ends – External thread inserted wide metal-to-metal spherical plain bearing rod end (inch dimensions), anodized titanium rod end body, corrosion-resistant-steel inner ring and bronze aluminium outer ring with lubrication by the rod end body	3.32	374	TRCEI..	Airframe rolling bearings – Deep groove ball bearing with self-aligning ring single row, EN 4041 (metric dimensions), cadmium plated bearing steel bearing and cadmium plated steel self-aligning ring	1.8	56
TEMJ/WQMLC..R	For the bearing used in this rod end, see WQML..			UFJ/XRE..	For the cross-reference designation of this legacy product, see FJ/NAS.., EFJ/NAS..		
TEMJ/WQML..R	Airframe rod ends – External thread inserted wide metal-to-metal spherical plain bearing rod end (inch dimensions), anodized titanium rod end body, corrosion-resistant-steel inner ring and bronze aluminium outer ring without lubrication groove	3.32	374	UFJ/XRL..	For the cross-reference designation of this legacy product, see FJ/WAS.., EFJ/WAS..		
TEMJ/WQML..R	For the bearing used in this rod end, see WQML..			UMJ/XRE..	For the cross-reference designation of this legacy product, see MJ/NAS.., EMJ/NAS..		
TEMJ/WQMLS..R	Airframe rod ends – External thread inserted wide metal-to-metal spherical plain bearing rod end (inch dimensions), anodized titanium rod end body, corrosion-resistant-steel inner ring and bronze aluminium outer ring with lubrication by the inner ring	3.32	374	UMJ/XRL..	For the cross-reference designation of this legacy product, see MJ/WAS.., EMJ/WAS..		
TEMJ/WQMLS..R	For the bearing used in this rod end, see WQML..			W2PL..	Airframe spherical plain bearings – Metal-to-metal swaged split (metric dimensions), corrosion-resistant-steel inner ring and outer ring not plated	2.9	258
TEMJ/WQMT..	Airframe rod ends – External thread inserted high misalignment metal-to-metal spherical plain bearing rod end (metric dimensions), anodized titanium rod end body, corrosion-resistant-steel inner ring and bronze aluminium outer ring	3.10	314	W2PL..	Airframe spherical plain bearings – Metal-to-metal swaged split (inch dimensions), corrosion-resistant-steel inner ring and outer ring not plated	2.17	210
TEMJ/WQMT..	For the bearing used in this rod end, see WQMT..			WAG..	Airframe rolling bearings – Deep groove ball bearing double row (metric dimensions), not plated corrosion-resistant-steel	1.5	60

¹⁾ Starting page of the product table.

Designation	Product	Product table		Designation	Product	Product table	
		No.	Page ¹⁾			No.	Page ¹⁾
WAGN..	Airframe rolling bearings – Deep groove ball bearing double row, EN 3058 (metric dimensions), not plated corrosion-resistant-steel	1.6	62	WCN..JESP..	Airframe rod ends – External thread rod end with integrated rolling bearing (inch dimensions), sealed bearing in corrosion-resistant-steel and rod end body in cadmium plated steel with UNJF profile thread	3.14	322
WAS..	Airframe spherical plain bearings – Self-lubricating narrow, AS 14102, AS 14103 (inch dimensions), 440C inner ring and not plated outer ring	2.29	248	WCN..JSP..	Airframe rod ends – External thread rod end with integrated rolling bearing (inch dimensions), shielded bearing in corrosion-resistant-steel and rod end body in cadmium plated steel with UNJF profile thread	3.14	322
WAS..	For rod ends using this bearing, see MJ/WAS..., SMJ/WAS..., PHMJ/WAS..., FJ/WAS..., SFJ/WAS..., PHFJ/WAS..., EMJ/RL...R..., SEMJ/RL...R..., XEMJ/RL...R..., TEMJ/RL...R..., EFJ/RL...R..., SEFJ/RL...R..., XEFJ/RL...R..., TEFJ/RL...R..			WCN..M	Airframe rod ends – External thread rod end with integrated rolling bearing (metric dimensions), shielded bearing in corrosion-resistant-steel and rod end body in cadmium plated steel	3.2	298
WAS..A..	Airframe spherical plain bearings – Self-lubricating narrow, AS 81820/2, AS 81820/3 (inch dimensions), 440C inner ring and not plated outer ring	2.30	252	WCN..ME	Airframe rod ends – External thread rod end with integrated rolling bearing (metric dimensions), sealed bearing in corrosion-resistant-steel and rod end body in cadmium plated steel	3.2	298
WATA..	Airframe rolling bearings – Deep groove ball bearing single row, EN 3283, EN 4033 (metric dimensions), not plated corrosion-resistant-steel	1.4	58	WCN..MESP..	Airframe rod ends – External thread rod end with integrated rolling bearing (inch dimensions), sealed bearing in corrosion-resistant-steel and rod end body in cadmium plated steel with UNF profile thread	3.14	322
WATRCE..	Airframe rolling bearings – Deep groove ball bearing with self-aligning ring single row (metric dimensions), corrosion-resistant-steel bearing and cadmium plated steel self-aligning ring	1.7	64	WCN..MESP1	Airframe rod ends – External thread rod end with integrated rolling bearing (metric dimensions), sealed bearing in corrosion-resistant-steel and rod end body in cadmium plated steel	3.2	298
WATRCEI..	Airframe rolling bearings – Deep groove ball bearing with self-aligning ring single row (metric dimensions), corrosion-resistant-steel bearing and cadmium plated steel self-aligning ring	1.8	56	WCN..MJ..	Airframe rod ends – External thread rod end with integrated rolling bearing (metric dimensions), bearing in corrosion-resistant-steel and rod end body in cadmium plated steel	3.1	296
WB5..	Airframe rolling bearings – Deep groove ball bearing single row (inch dimensions), corrosion-resistant-steel, standard tolerance	1.18	92	WCN..MSP..	Airframe rod ends – External thread rod end with integrated rolling bearing (inch dimensions), shielded bearing in corrosion-resistant-steel and rod end body in cadmium plated steel with UNF profile thread	3.14	322
WB55..	Airframe rolling bearings – Deep groove ball bearing double row (inch dimensions), corrosion-resistant-steel	1.19	96	WCN..MSP1	Airframe rod ends – External thread rod end with integrated rolling bearing (metric dimensions), shielded bearing in corrosion-resistant-steel and rod end body in cadmium plated steel	3.2	298
WC..M	Airframe rod ends – External thread rod end with integrated rolling bearing (metric dimensions), shielded bearing in corrosion-resistant-steel and rod end body in cadmium plated steel	3.2	298	WDPP..	Airframe rolling bearings – Deep groove ball bearing double row (inch dimensions), corrosion-resistant-steel, standard tolerance	1.20	98
WC..ME	Airframe rod ends – External thread rod end with integrated rolling bearing (metric dimensions), sealed bearing in corrosion-resistant-steel and rod end body in cadmium plated steel	3.2	298	WDSP..	Airframe rolling bearings – Self-aligning ball bearing double row (inch dimensions), corrosion-resistant-steel, standard tolerance	1.26	114
WC..MJ..	Airframe rod ends – External thread rod end with integrated rolling bearing (metric dimensions), bearing in corrosion-resistant-steel and rod end body in cadmium plated steel	3.1	296	WDSRP..	Airframe rolling bearings – Spherical roller bearing single row (inch dimensions), corrosion-resistant-steel	1.27	116
WCN...-	Airframe rod ends – External thread rod end with integrated rolling bearing, EN 4157 (inch dimensions), shielded bearing in corrosion-resistant-steel and rod end body in cadmium plated steel	3.15	326	WDW..	Airframe rolling bearings – Deep groove ball bearing double row (inch dimensions), corrosion-resistant-steel, standard tolerance	1.21	100
WCN..E..	Airframe rod ends – External thread rod end with integrated rolling bearing EN 4157 (inch dimensions), sealed bearing in corrosion-resistant-steel and rod end body in cadmium plated steel	3.15	326	WDW..K	Airframe rolling bearings – Deep groove ball bearing double row (inch dimensions), corrosion-resistant-steel, standard tolerance	1.21	100

¹⁾ Starting page of the product table.

Designation	Product	Product table		Designation	Product	Product table	
		No.	Page ¹⁾			No.	Page ¹⁾
WDW..K2	Airframe rolling bearings – Deep groove ball bearing double row (inch dimensions), corrosion-resistant-steel, standard tolerance	1.21	100	WJN..	Airframe rolling bearings – Deep groove ball bearing single row (metric dimensions), not plated corrosion-resistant-steel	1.1	52
WEF..	Airframe rod ends – Internal thread integrated metal-to-metal spherical plain bearing rod end (metric dimensions), corrosion-resistant-steel inner ring and cadmium plated steel rod end body	3.8	316	WJNA..	Airframe rolling bearings – Deep groove ball bearing single row, EN 3286, EN 3047 (metric dimensions), not plated corrosion-resistant-steel	1.2	54
WEM..	Airframe rod ends – External thread integrated metal-to-metal spherical plain bearing rod end (metric dimensions), corrosion-resistant-steel inner ring and cadmium plated steel rod end body	3.8	310	WK..	Airframe rolling bearings – Spherical roller bearing single row, EN 3055 (metric dimensions), not plated corrosion-resistant-steel	1.11	72
WEN..	Airframe spherical plain bearings – Self-lubricating wide, EN 2585, EN 4039 (metric dimensions), not plated	2.20	220	WK..D	Airframe rolling bearings – Spherical roller bearing double row (metric dimensions), not plated corrosion-resistant-steel	1.13	76
WEN..	For rod ends using this bearing, see EMJ/RL..., SEMJ/RL..., XEMJ/RL..., TEMJ/RL..., EFJ/RL..., SEFJ/RL..., XEFJ/RL..., TEFJ/RL...			WK..F	Airframe rolling bearings – Spherical roller bearing single row, EN 3055 (metric dimensions), not plated corrosion-resistant-steel	1.11	72
WGE..	Airframe spherical plain bearings – Metal-to-metal loader slot, EN 2588 (metric dimensions), corrosion-resistant-steel inner ring and outer ring not plated	2.1	156	WKN..	Airframe rolling bearings – Self-aligning ball bearing double row, EN 3289 (metric dimensions), not plated corrosion-resistant-steel	1.9	68
WGL..	Airframe spherical plain bearings – Metal-to-metal loader slot normal (metric dimensions), corrosion-resistant-steel inner ring and outer ring not plated	2.2	160	WKN..	Airframe rolling bearings – Self-aligning ball bearing double row (inch dimensions), not plated corrosion-resistant-steel	1.25	112
WGLD..	Airframe spherical plain bearings – Metal-to-metal loader slot normal (metric dimensions), corrosion-resistant-steel inner ring and outer ring not plated	2.2	160	WKN..	Airframe rolling bearings – Spherical roller bearing single row, EN 3055 (metric dimensions), not plated corrosion-resistant-steel	1.11	72
WGLS..	Airframe spherical plain bearings – Metal-to-metal loader slot normal (metric dimensions), corrosion-resistant-steel inner ring and outer ring not plated	2.2	160	WKNA..F	Airframe rolling bearings – Spherical roller bearing single row, EN 3292 (metric dimensions), not plated corrosion-resistant-steel	1.12	74
WGLS..MRTG	Airframe spherical plain bearings – Metal-to-metal loader slot normal reinforced (metric dimensions), corrosion-resistant-steel inner ring and outer ring not plated with molybdenum disulfide	2.3	164	WKN..F	Airframe rolling bearings – Spherical roller bearing single row, EN 3055 (metric dimensions), not plated corrosion-resistant-steel	1.11	72
WGLS..RTG	Airframe spherical plain bearings – Metal-to-metal loader slot normal reinforced (metric dimensions), corrosion-resistant-steel inner ring and outer ring not plated	2.3	164	WKNRCE..	Airframe rolling bearings – Self-aligning ball bearing double row, EN 4034 (metric dimensions), not plated corrosion-resistant-steel	1.10	70
WGLS..TAG	Airframe spherical plain bearings – Metal-to-metal loader slot normal (metric dimensions), corrosion-resistant-steel inner ring and outer ring not plated	2.2	160	WKP..	Airframe rolling bearings – Deep groove ball bearing single row (inch dimensions), corrosion-resistant-steel, standard tolerance	1.14	78
WGT..	Airframe spherical plain bearings – Metal-to-metal loader slot wide (metric dimensions), corrosion-resistant-steel inner ring and outer ring not plated	2.4	166	WKP..A	Airframe rolling bearings – Deep groove ball bearing single row (inch dimensions), corrosion-resistant-steel, standard tolerance	1.15	80
WGT..	Airframe spherical plain bearings – Metal-to-metal loader slot wide (inch dimensions), corrosion-resistant-steel inner ring and outer ring not plated	2.10	184	WKP..APSP..	Airframe rolling bearings – Deep groove ball bearing single row (inch dimensions), corrosion-resistant-steel, shielded	1.17	90
				WKP..ASP..	Airframe rolling bearings – Deep groove ball bearing single row (inch dimensions), corrosion-resistant-steel, sealed	1.17	90
				WKP..B	Airframe rolling bearings – Deep groove ball bearing single row (inch dimensions), corrosion-resistant-steel, standard tolerance	1.16	84

¹⁾ Starting page of the product table.

Designation	Product	Product table		Designation	Product	Product table	
		No.	Page ¹⁾			No.	Page ¹⁾
WKP..BS	Airframe rolling bearings – Deep groove ball bearing with self-aligning ring single row (inch dimensions), corrosion-resistant-steel, standard tolerance	1.22	102	WMDSP..	Airframe rolling bearings – Self-aligning ball bearing double row (inch dimensions), corrosion-resistant-steel, reduced tolerance and SKF super precision	1.26	114
WKP..L	Airframe rolling bearings – Deep groove ball bearing single row (inch dimensions), corrosion-resistant-steel, standard tolerance	1.14	78	WMDW..	Airframe rolling bearings – Deep groove ball bearing double row (inch dimensions), corrosion-resistant-steel, reduced tolerance and SKF super precision	1.21	100
WKP..LPSP..	Airframe rolling bearings – Deep groove ball bearing single row (inch dimensions), corrosion-resistant-steel, shielded	1.17	90	WMDW..K	Airframe rolling bearings – Deep groove ball bearing double row (inch dimensions), corrosion-resistant-steel, reduced tolerance and SKF super precision	1.21	100
WKP..LSP..	Airframe rolling bearings – Deep groove ball bearing single row (inch dimensions), corrosion-resistant-steel, sealed	1.17	90	WMDW..K2	Airframe rolling bearings – Deep groove ball bearing double row (inch dimensions), corrosion-resistant-steel, reduced tolerance and SKF super precision	1.21	100
WKP..PSP..	Airframe rolling bearings – Deep groove ball bearing single row (inch dimensions), corrosion-resistant-steel, shielded	1.17	90	WME..	Airframe spherical plain bearings – Metal-to-metal swaged narrow (metric dimensions), corrosion-resistant-steel inner ring and outer ring not plated	2.6	172
WKP..SP..	Airframe rolling bearings – Deep groove ball bearing single row (inch dimensions), corrosion-resistant-steel, sealed	1.17	90	WME..	Airframe spherical plain bearings – Metal-to-metal swaged narrow (inch dimensions), corrosion-resistant-steel inner ring and outer ring not plated	2.11	186
WKSP..	Airframe rolling bearings – Self-aligning ball bearing single row (inch dimensions), corrosion-resistant-steel, standard tolerance	1.23	106	WMKP..	Airframe rolling bearings – Deep groove ball bearing single row (inch dimensions), corrosion-resistant-steel, reduced tolerance and SKF super precision	1.14	78
WKSP..A	Airframe rolling bearings – Self-aligning ball bearing single row (inch dimensions), corrosion-resistant-steel, standard tolerance	1.23	106	WMKP..A	Airframe rolling bearings – Deep groove ball bearing single row (inch dimensions), corrosion-resistant-steel, reduced tolerance and SKF super precision	1.15	80
WKSP..APSP..	Airframe rolling bearings – Self-aligning ball bearing single row (inch dimensions), corrosion-resistant-steel, shielded	1.24	110	WMKP..B	Airframe rolling bearings – Deep groove ball bearing single row (inch dimensions), corrosion-resistant-steel, reduced tolerance and SKF super precision	1.16	84
WKSP..ASP..	Airframe rolling bearings – Self-aligning ball bearing single row (inch dimensions), corrosion-resistant-steel, sealed	1.24	110	WMKP..BS	Airframe rolling bearings – Deep groove ball bearing with self-aligning ring single row (inch dimensions), corrosion-resistant-steel, reduced tolerance and SKF super precision	1.22	102
WKSP..L	Airframe rolling bearings – Self-aligning ball bearing single row (inch dimensions), corrosion-resistant-steel, standard tolerance	1.23	106	WMKP..L	Airframe rolling bearings – Deep groove ball bearing single row (inch dimensions), corrosion-resistant-steel, reduced tolerance and SKF super precision	1.14	78
WKSP..PSP..	Airframe rolling bearings – Self-aligning ball bearing single row (inch dimensions), corrosion-resistant-steel, shielded	1.24	110	WMKSP..	Airframe rolling bearings – Self-aligning ball bearing single row (inch dimensions), corrosion-resistant-steel, reduced tolerance and SKF super precision	1.23	106
WKSP..SP..	Airframe rolling bearings – Self-aligning ball bearing single row (inch dimensions), corrosion-resistant-steel, sealed	1.24	110	WMKSP..A	Airframe rolling bearings – Self-aligning ball bearing single row (inch dimensions), corrosion-resistant-steel, reduced tolerance and SKF super precision	1.23	106
WMA..	Airframe spherical plain bearings – Metal-to-metal swaged light, EN 2335 (metric dimensions), corrosion-resistant-steel inner ring and outer ring not plated	2.5	168	WMKSP..L	Airframe rolling bearings – Self-aligning ball bearing single row (inch dimensions), corrosion-resistant-steel, reduced tolerance and SKF super precision	1.23	106
WMB5..	Airframe rolling bearings – Deep groove ball bearing single row (inch dimensions), corrosion-resistant-steel, reduced clearance and precision	1.18	92				
WMDPP..	Airframe rolling bearings – Deep groove ball bearing double row (inch dimensions), corrosion-resistant-steel, reduced tolerance and SKF super precision	1.20	98				

¹⁾ Starting page of the product table.

Designation	Product	Product table		Designation	Product	Product table	
		No.	Page ¹⁾			No.	Page ¹⁾
WML..	Airframe spherical plain bearings – Metal-to-metal swaged wide (metric dimensions), corrosion-resistant-steel inner ring and outer ring not plated	2.7	176	WQME..	Airframe spherical plain bearings – Metal-to-metal swaged narrow (metric dimensions), corrosion-resistant-steel inner ring and bronze aluminium outer ring not plated	2.6	172
WML..	Airframe spherical plain bearings – Metal-to-metal swaged wide (inch dimensions), corrosion-resistant-steel inner ring and outer ring not plated	2.13	194	WQME..	Airframe spherical plain bearings – Metal-to-metal swaged narrow (inch dimensions), corrosion-resistant-steel inner ring and bronze aluminium outer ring not plated	2.11	186
WML..	For rod ends using this bearing, see EMJ/WML.., SEMJ/WML.., SEMJ/WML.., TEMJ/WML.., EFJ/WML.., SEFJ/WML.., SEFJ/WML.., TEFJ/WML.., EMJ/WML..R, SEMJ/WML..R, SEMJ/WML..R, TEMJ/WML..R, EFJ/WML..R, SEFJ/WML..R, SEFJ/WML..R, TEFJ/WML..R, EMJ/WML..R, SEMJ/WML..R, XEMJ/WML..R, TEMJ/WML..R, EFJ/WML..R, SEFJ/WML..R, XEFJ/WML..R, TEFJ/WML..R, EMJ/WMLC..R, SEMJ/WMLC..R, XEMJ/WMLC..R, TEMJ/WMLC..R, EFJ/WMLC..R, SEFJ/WMLC..R, XEFJ/WMLC..R, TEFJ/WMLC..R			WQML..	Airframe spherical plain bearings – Metal-to-metal swaged wide (metric dimensions), corrosion-resistant-steel inner ring and bronze aluminium outer ring not plated	2.7	176
WML..	For rod ends using this bearing, see EMJ/WML.., SEMJ/WML.., SEMJ/WML.., TEMJ/WML.., EFJ/WML.., SEFJ/WML.., SEFJ/WML.., TEFJ/WML.., EMJ/WML..R, SEMJ/WML..R, SEMJ/WML..R, TEMJ/WML..R, EFJ/WML..R, SEFJ/WML..R, SEFJ/WML..R, TEFJ/WML..R, EMJ/WML..R, SEMJ/WML..R, XEMJ/WML..R, TEMJ/WML..R, EFJ/WML..R, SEFJ/WML..R, XEFJ/WML..R, TEFJ/WML..R, EMJ/WMLC..R, SEMJ/WMLC..R, XEMJ/WMLC..R, TEMJ/WMLC..R, EFJ/WMLC..R, SEFJ/WMLC..R, XEFJ/WMLC..R, TEFJ/WMLC..R			WQML..	Airframe spherical plain bearings – Metal-to-metal swaged wide (inch dimensions), corrosion-resistant-steel inner ring and bronze aluminium outer ring not plated	2.13	194
WMT..	Airframe spherical plain bearings – Metal-to-metal swaged high misalignment (metric dimensions), corrosion-resistant-steel inner ring and outer ring not plated	2.8	180	WQML..	For rod ends using this bearing, see EMJ/WQML.., SEMJ/WQML.., SEMJ/WQML.., TEMJ/WQML.., EFJ/WQML.., SEFJ/WQML.., SEFJ/WQML.., TEFJ/WQML.., EMJ/WQML..R, SEMJ/WQML..R, SEMJ/WQML..R, TEMJ/WQML..R, EFJ/WQML..R, SEFJ/WQML..R, SEFJ/WQML..R, TEFJ/WQML..R, EMJ/WQML..R, SEMJ/WQML..R, XEMJ/WQML..R, TEMJ/WQML..R, EFJ/WQML..R, SEFJ/WQML..R, XEFJ/WQML..R, TEFJ/WQML..R, EMJ/WQMLC..R, SEMJ/WQMLC..R, XEMJ/WQMLC..R, TEMJ/WQMLC..R, EFJ/WQMLC..R, SEFJ/WQMLC..R, XEFJ/WQMLC..R, TEFJ/WQMLC..R		
WMT..	Airframe spherical plain bearings – Metal-to-metal swaged high misalignment (inch dimensions), corrosion-resistant-steel inner ring and outer ring not plated	2.15	202	WQMT..	Airframe spherical plain bearings – Metal-to-metal swaged high misalignment (metric dimensions), corrosion-resistant-steel inner ring and bronze aluminium outer ring not plated	2.8	180
WMT..	For rod ends using this bearing, see EMJ/WMT.., SEMJ/WMT.., SEMJ/WMT.., TEMJ/WMT.., EFJ/WMT.., SEFJ/WMT.., SEFJ/WMT.., TEFJ/WMT.., EMJ/WMT..R, SEMJ/WMT..R, SEMJ/WMT..R, TEMJ/WMT..R, EFJ/WMT..R, SEFJ/WMT..R, SEFJ/WMT..R, TEFJ/WMT..R, EMJ/WMTS..R, SEMJ/WMTS..R, XEMJ/WMTS..R, TEMJ/WMTS..R, EFJ/WMTS..R, SEFJ/WMTS..R, XEFJ/WMTS..R, TEFJ/WMTS..R, EMJ/WMTC..R, SEMJ/WMTC..R, XEMJ/WMTC..R, TEMJ/WMTC..R, EFJ/WMTC..R, SEFJ/WMTC..R, XEFJ/WMTC..R, TEFJ/WMTC..R			WQMT..	Airframe spherical plain bearings – Metal-to-metal swaged high misalignment (inch dimensions), corrosion-resistant-steel inner ring and bronze aluminium outer ring not plated	2.15	202
WQ2PL..	Airframe spherical plain bearings – Metal-to-metal swaged split (metric dimensions), corrosion-resistant-steel inner ring and bronze aluminium outer ring not plated	2.9	182	WQMT..	For rod ends using this bearing, see EMJ/WQMT.., SEMJ/WQMT.., SEMJ/WQMT.., TEMJ/WQMT.., EFJ/WQMT.., SEFJ/WQMT.., SEFJ/WQMT.., TEFJ/WQMT.., EMJ/WQMT..R, SEMJ/WQMT..R, SEMJ/WQMT..R, TEMJ/WQMT..R, EFJ/WQMT..R, SEFJ/WQMT..R, SEFJ/WQMT..R, TEFJ/WQMT..R, EMJ/WQMTS..R, SEMJ/WQMTS..R, XEMJ/WQMTS..R, TEMJ/WQMTS..R, EFJ/WQMTS..R, SEFJ/WQMTS..R, XEFJ/WQMTS..R, TEFJ/WQMTS..R, EMJ/WQMTC..R, SEMJ/WQMTC..R, XEMJ/WQMTC..R, TEMJ/WQMTC..R, EFJ/WQMTC..R, SEFJ/WQMTC..R, XEFJ/WQMTC..R, TEFJ/WQMTC..R		
WQ2PL..	Airframe spherical plain bearings – Metal-to-metal swaged split (inch dimensions), corrosion-resistant-steel inner ring and bronze aluminium outer ring not plated	2.17	210				
WQMA..	Airframe spherical plain bearings – Metal-to-metal swaged light (metric dimensions), corrosion-resistant-steel inner ring and bronze aluminium outer ring not plated	2.5	168				

¹⁾ Starting page of the product table.

Designation	Product	Product table		Designation	Product	Product table	
		No.	Page ¹⁾			No.	Page ¹⁾
WRA..M..	Airframe rod ends – External thread rod end with integrated rolling bearing (inch dimensions), bearing in corrosion-resistant-steel and rod end body in cadmium plated steel with right-hand thread	3.16	332	WZGE..	Airframe spherical plain bearings – Metal-to-metal loader slot (metric dimensions), corrosion-resistant-steel inner ring and outer ring cadmium plated	2.1	156
WRA..ML..	Airframe rod ends – External thread rod end with integrated rolling bearing (inch dimensions), bearing in corrosion-resistant-steel and rod end body in cadmium plated steel with left-hand thread	3.16	332	WZK..F	Airframe rolling bearings – Spherical roller bearing single row (metric dimensions), cadmium plated corrosion-resistant-steel	1.11	72
WRAP..M..	Airframe rod ends – External thread rod end with integrated rolling bearing (inch dimensions), bearing in corrosion-resistant-steel and rod end body in cadmium plated steel with right-hand thread	3.16	332	XC..M	Airframe rod ends – External thread rod end with integrated rolling bearing (metric dimensions), shielded bearing in corrosion-resistant-steel and rod end body in corrosion-resistant-steel	3.2	298
WRAP..ML..	Airframe rod ends – External thread rod end with integrated rolling bearing (inch dimensions), bearing in corrosion-resistant-steel and rod end body in cadmium plated steel with left-hand thread	3.16	332	XC..ME	Airframe rod ends – External thread rod end with integrated rolling bearing (metric dimensions), sealed bearing in corrosion-resistant-steel and rod end body in corrosion-resistant-steel	3.2	298
WREP..	Airframe rod ends – Internal thread rod end with integrated rolling bearing (inch dimensions), bearing in corrosion-resistant-steel and rod end body in cadmium plated steel with right-hand thread	3.17	334	XC..MJ..	Airframe rod ends – External thread rod end with integrated rolling bearing, EN 4036 (metric dimensions), bearing in corrosion-resistant-steel and rod end body in corrosion-resistant-steel	3.1	296
WREP..F..	Airframe rod ends – Internal thread rod end with integrated rolling bearing (inch dimensions), bearing in corrosion-resistant-steel and rod end body in cadmium plated steel with right-hand thread	3.17	334	XCN..-..	Airframe rod ends – External thread rod end with integrated rolling bearing (inch dimensions), shielded bearing in corrosion-resistant-steel and rod end body in corrosion-resistant-steel	3.15	326
WREP..FL..	Airframe rod ends – Internal thread rod end with integrated rolling bearing (inch dimensions), bearing in corrosion-resistant-steel and rod end body in cadmium plated steel with left-hand thread	3.17	334	XCN..E..	Airframe rod ends – External thread rod end with integrated rolling bearing (inch dimensions), sealed bearing in corrosion-resistant-steel and rod end body in corrosion-resistant-steel	3.15	326
WREP..L..	Airframe rod ends – Internal thread rod end with integrated rolling bearing (inch dimensions), bearing in corrosion-resistant-steel and rod end body in cadmium plated steel with left-hand thread	3.17	334	XCN..JESP..	Airframe rod ends – External thread rod end with integrated rolling bearing (inch dimensions), sealed bearing in corrosion-resistant-steel and rod end body in corrosion-resistant-steel with UNJF profile thread	3.14	322
WREP..M..	Airframe rod ends – External thread rod end with integrated rolling bearing (inch dimensions), bearing in corrosion-resistant-steel and rod end body in cadmium plated steel with right-hand thread	3.16	332	XCN..JSP..	Airframe rod ends – External thread rod end with integrated rolling bearing (inch dimensions), shielded bearing in corrosion-resistant-steel and rod end body in corrosion-resistant-steel with UNJF profile thread	3.14	322
WREP..ML..	Airframe rod ends – External thread rod end with integrated rolling bearing (inch dimensions), bearing in corrosion-resistant-steel and rod end body in cadmium plated steel with left-hand thread	3.16	332	XCN..M	Airframe rod ends – External thread rod end with integrated rolling bearing (metric dimensions), shielded bearing in corrosion-resistant-steel and rod end body in corrosion-resistant-steel	3.2	298
WREP..MR..	Airframe rod ends – External thread rod end with integrated rolling bearing (inch dimensions), bearing in corrosion-resistant-steel and rod end body in cadmium plated steel with right-hand thread	3.16	332	XCN..ME	Airframe rod ends – External thread rod end with integrated rolling bearing (metric dimensions), sealed bearing in corrosion-resistant-steel and rod end body in corrosion-resistant-steel	3.2	298
WT..	Airframe rolling bearings – Deep groove ball bearing single row (metric dimensions), not plated corrosion-resistant-steel	1.3	56	XCN..MESP..	Airframe rod ends – External thread rod end with integrated rolling bearing (inch dimensions), sealed bearing in corrosion-resistant-steel and rod end body in corrosion-resistant-steel with UNF profile thread	3.14	322
				XCN..MESP1	Airframe rod ends – External thread rod end with integrated rolling bearing (metric dimensions), sealed bearing in corrosion-resistant-steel and rod end body in corrosion-resistant-steel	3.2	298

¹⁾ Starting page of the product table.

Designation	Product	Product table		Designation	Product	Product table	
		No.	Page ¹⁾			No.	Page ¹⁾
XCN..MJ..	Airframe rod ends – External thread rod end with integrated rolling bearing, EN 4036 (metric dimensions), bearing in corrosion-resistant-steel and rod end body in corrosion-resistant-steel	3.1	296	XEFJ/QMTS..R	Airframe rod ends – Internal thread inserted high misalignment metal-to-metal spherical plain bearing rod end (inch dimensions), corrosion-resistant-steel rod end body, bronze beryllium inner ring and corrosion-resistant-steel outer ring with lubrication by the inner ring	3.35	380
XCN..MSP..	Airframe rod ends – External thread rod end with integrated rolling bearing (inch dimensions), shielded bearing in corrosion-resistant-steel and rod end body in corrosion-resistant-steel with UNF profile thread	3.14	322	XEFJ/QMTS..R	For the bearing used in this rod end, see QMT..		
XCN..MSP1	Airframe rod ends – External thread rod end with integrated rolling bearing (metric dimensions), shielded bearing in corrosion-resistant-steel and rod end body in corrosion-resistant-steel	3.2	298	XEFJ/RL..	Airframe rod ends – Internal thread inserted wide self-lubricating spherical plain bearing rod end (metric dimensions), 17-4PH H1025 corrosion-resistant-steel rod end	3.6	306
XEF..	Airframe rod ends – Internal thread integrated metal-to-metal spherical plain bearing rod end (metric dimensions), corrosion-resistant-steel inner ring and corrosion-resistant-steel rod end body	3.8	316	XEFJ/RL..	For the bearing used in this rod end, see WEN..		
XEFJ/QMLC..R	Airframe rod ends – Internal thread inserted wide metal-to-metal spherical plain bearing rod end (inch dimensions), corrosion-resistant-steel rod end body, bronze beryllium inner ring and corrosion-resistant-steel outer ring with lubrication by the rod end body	3.34	378	XEFJ/RL..R..	Airframe rod ends – Internal thread inserted wide self-lubricating spherical plain bearing rod end (inch dimensions), zinc-nickel plated 30NCD16 steel rod end	3.30	370
XEFJ/QMLC..R	For the bearing used in this rod end, see QML..			XEFJ/RL..R..	For the bearing used in this rod end, see WAS..		
XEFJ/QML..R	Airframe rod ends – Internal thread inserted wide metal-to-metal spherical plain bearing rod end (inch dimensions), corrosion-resistant-steel rod end body, bronze beryllium inner ring and corrosion-resistant-steel outer ring without lubrication groove	3.34	378	XEFJ/RL..R..	Airframe rod ends – Internal thread inserted wide self-lubricating spherical plain bearing rod end (inch dimensions), 17-4PH H1025 corrosion-resistant-steel rod end	3.30	370
XEFJ/QML..R	For the bearing used in this rod end, see QML..			XEFJ/RL..R..	For the bearing used in this rod end, see WAS..		
XEFJ/QMLS..R	Airframe rod ends – Internal thread inserted wide metal-to-metal spherical plain bearing rod end (inch dimensions), corrosion-resistant-steel rod end body, bronze beryllium inner ring and corrosion-resistant-steel outer ring with lubrication by the inner ring	3.34	378	XEFJ/RT..	Airframe rod ends – Internal thread inserted high-misalignment self-lubricating spherical plain bearing rod end (metric dimensions), 17-4PH H1025 corrosion-resistant-steel rod end	3.7	308
XEFJ/QMLS..R	For the bearing used in this rod end, see QML..			XEFJ/RT..	For the bearing used in this rod end, see XRT..		
XEFJ/QMTC..R	Airframe rod ends – Internal thread inserted high misalignment metal-to-metal spherical plain bearing rod end (inch dimensions), corrosion-resistant-steel rod end body, bronze beryllium inner ring and corrosion-resistant-steel outer ring with lubrication by the rod end body	3.35	380	XEFJ/RT..R..	Airframe rod ends – Internal thread inserted high-misalignment self-lubricating spherical plain bearing rod end (inch dimensions), 17-4PH H1025 corrosion-resistant-steel rod end	3.31	372
XEFJ/QMTC..R	For the bearing used in this rod end, see QMT..			XEFJ/RT..R..	For the bearing used in this rod end, see XRT..		
XEFJ/QMT..R	Airframe rod ends – Internal thread inserted high misalignment metal-to-metal spherical plain bearing rod end (inch dimensions), corrosion-resistant-steel rod end body, bronze beryllium inner ring and corrosion-resistant-steel outer ring without lubrication groove	3.35	380	XEFJ/WMLC..R	Airframe rod ends – Internal thread inserted wide metal-to-metal spherical plain bearing rod end (inch dimensions), corrosion-resistant-steel rod end body, corrosion-resistant-steel inner ring and corrosion-resistant-steel outer ring with lubrication by the rod end body	3.34	378
XEFJ/QMT..R	For the bearing used in this rod end, see QMT..			XEFJ/WMLC..R	For the bearing used in this rod end, see WML..		
XEFJ/QMT..R	Airframe rod ends – Internal thread inserted wide metal-to-metal spherical plain bearing rod end (inch dimensions), corrosion-resistant-steel rod end body, corrosion-resistant-steel inner ring and corrosion-resistant-steel outer ring without lubrication groove	3.34	378	XEFJ/WML..R	Airframe rod ends – Internal thread inserted wide metal-to-metal spherical plain bearing rod end (inch dimensions), corrosion-resistant-steel rod end body, corrosion-resistant-steel inner ring and corrosion-resistant-steel outer ring without lubrication groove	3.34	378
XEFJ/QMT..R	For the bearing used in this rod end, see QMT..			XEFJ/WML..R	For the bearing used in this rod end, see WML..		

¹⁾ Starting page of the product table.

Designation	Product	Product table No. Page ¹⁾	Designation	Product	Product table No. Page ¹⁾
XEFJ/WMLS..R	Airframe rod ends – Internal thread inserted wide metal-to-metal spherical plain bearing rod end (inch dimensions), corrosion-resistant-steel rod end body, corrosion-resistant-steel inner ring and corrosion-resistant-steel outer ring with lubrication by the inner ring	3.34 378	XEFJ/WQMT..R	Airframe rod ends – Internal thread inserted high misalignment metal-to-metal spherical plain bearing rod end (inch dimensions), corrosion-resistant-steel rod end body, corrosion-resistant-steel inner ring and bronze aluminium outer ring with lubrication by the rod end body	3.35 380
XEFJ/WMLS..R	For the bearing used in this rod end, see WML..		XEFJ/WQMT..R	For the bearing used in this rod end, see WQMT..	
XEFJ/WMTC..R	Airframe rod ends – Internal thread inserted high misalignment metal-to-metal spherical plain bearing rod end (inch dimensions), corrosion-resistant-steel rod end body, corrosion-resistant-steel inner ring and corrosion-resistant-steel outer ring with lubrication by the rod end body	3.35 380	XEFJ/WQMT..R	Airframe rod ends – Internal thread inserted high misalignment metal-to-metal spherical plain bearing rod end (inch dimensions), corrosion-resistant-steel rod end body, corrosion-resistant-steel inner ring and bronze aluminium outer ring without lubrication groove	3.35 380
XEFJ/WMTC..R	For the bearing used in this rod end, see WMT..		XEFJ/WQMT..R	For the bearing used in this rod end, see WQMT..	
XEFJ/WMT..R	Airframe rod ends – Internal thread inserted high misalignment metal-to-metal spherical plain bearing rod end (inch dimensions), corrosion-resistant-steel rod end body, corrosion-resistant-steel inner ring and corrosion-resistant-steel outer ring without lubrication groove	3.35 380	XEFJ/WQMTS..R	Airframe rod ends – Internal thread inserted high misalignment metal-to-metal spherical plain bearing rod end (inch dimensions), corrosion-resistant-steel rod end body, corrosion-resistant-steel inner ring and bronze aluminium outer ring with lubrication by the inner ring	3.35 380
XEFJ/WMT..R	For the bearing used in this rod end, see WMT..		XEFJ/WQMTS..R	For the bearing used in this rod end, see WQMT..	
XEFJ/WMTS..R	Airframe rod ends – Internal thread inserted high misalignment metal-to-metal spherical plain bearing rod end (inch dimensions), corrosion-resistant-steel rod end body, corrosion-resistant-steel inner ring and corrosion-resistant-steel outer ring with lubrication by the inner ring	3.35 380	XEM..	Airframe rod ends – External thread integrated metal-to-metal spherical plain bearing rod end (metric dimensions), corrosion-resistant-steel inner ring and corrosion-resistant-steel rod end body	3.8 310
XEFJ/WMTS..R	For the bearing used in this rod end, see WMT..		XEMA..	Airframe rod ends – External thread inserted self-lubricating spherical plain bearing rod end, EN 4198 (metric dimensions), 17-4PH H1025 corrosion-resistant-steel rod end	3.3 370
XEFJ/WMTC..R	Airframe rod ends – Internal thread inserted wide metal-to-metal spherical plain bearing rod end (inch dimensions), corrosion-resistant-steel rod end body, corrosion-resistant-steel inner ring and bronze aluminium outer ring with lubrication by the rod end body	3.34 378	XEMA..	For the bearing used in this rod end, see HMEN..R..	
XEFJ/WMTC..R	For the bearing used in this rod end, see WQML..		XEMJ/QMLC..R	Airframe rod ends – External thread inserted wide metal-to-metal spherical plain bearing rod end (inch dimensions), corrosion-resistant-steel rod end body, bronze beryllium inner ring and corrosion-resistant-steel outer ring with lubrication by the rod end body	3.32 374
XEFJ/WQML..R	Airframe rod ends – Internal thread inserted wide metal-to-metal spherical plain bearing rod end (inch dimensions), corrosion-resistant-steel rod end body, corrosion-resistant-steel inner ring and bronze aluminium outer ring without lubrication groove	3.34 378	XEMJ/QMLC..R	For the bearing used in this rod end, see QML..	
XEFJ/WQML..R	For the bearing used in this rod end, see WQML..		XEMJ/QML..R	Airframe rod ends – External thread inserted wide metal-to-metal spherical plain bearing rod end (inch dimensions), corrosion-resistant-steel rod end body, bronze beryllium inner ring and corrosion-resistant-steel outer ring without lubrication groove	3.32 374
XEFJ/WQMLS..R	Airframe rod ends – Internal thread inserted wide metal-to-metal spherical plain bearing rod end (inch dimensions), corrosion-resistant-steel rod end body, corrosion-resistant-steel inner ring and bronze aluminium outer ring with lubrication by the inner ring	3.34 378	XEMJ/QML..R	For the bearing used in this rod end, see QML..	
XEFJ/WQMLS..R	For the bearing used in this rod end, see WQML..		XEMJ/QMLS..R	Airframe rod ends – External thread inserted wide metal-to-metal spherical plain bearing rod end (inch dimensions), corrosion-resistant-steel rod end body, bronze beryllium inner ring and corrosion-resistant-steel outer ring with lubrication by the inner ring	3.32 374

¹⁾ Starting page of the product table.

Designation	Product	Product table		Designation	Product	Product table	
		No.	Page ¹⁾			No.	Page ¹⁾
XEMJ/QMLS..R	For the bearing used in this rod end, see QML..			XEMJ/WMLC..R	For the bearing used in this rod end, see WML..		
XEMJ/QMTC..R	Airframe rod ends – External thread inserted high misalignment metal-to-metal spherical plain bearing rod end (inch dimensions), corrosion-resistant-steel rod end body, bronze beryllium inner ring and corrosion-resistant-steel outer ring with lubrication by the rod end body	3.33	300	XEMJ/WML..R	Airframe rod ends – External thread inserted wide metal-to-metal spherical plain bearing rod end (inch dimensions), corrosion-resistant-steel rod end body, corrosion-resistant-steel inner ring and corrosion-resistant-steel outer ring without lubrication groove	3.32	374
XEMJ/QMTC..R	For the bearing used in this rod end, see QMT..			XEMJ/WML..R	For the bearing used in this rod end, see WML..		
XEMJ/QMT..R	Airframe rod ends – External thread inserted high misalignment metal-to-metal spherical plain bearing rod end (inch dimensions), corrosion-resistant-steel rod end body, bronze beryllium inner ring and corrosion-resistant-steel outer ring without lubrication groove	3.33	300	XEMJ/WMLS..R	Airframe rod ends – External thread inserted wide metal-to-metal spherical plain bearing rod end (inch dimensions), corrosion-resistant-steel rod end body, corrosion-resistant-steel inner ring and corrosion-resistant-steel outer ring with lubrication by the inner ring	3.32	374
XEMJ/QMT..R	For the bearing used in this rod end, see QMT..			XEMJ/WMLS..R	For the bearing used in this rod end, see WML..		
XEMJ/QMTS..R	Airframe rod ends – External thread inserted high misalignment metal-to-metal spherical plain bearing rod end (inch dimensions), corrosion-resistant-steel rod end body, bronze beryllium inner ring and corrosion-resistant-steel outer ring with lubrication by the inner ring	3.33	300	XEMJ/WMTC..R	Airframe rod ends – External thread inserted high misalignment metal-to-metal spherical plain bearing rod end (inch dimensions), corrosion-resistant-steel rod end body, corrosion-resistant-steel inner ring and corrosion-resistant-steel outer ring with lubrication by the rod end body	3.33	300
XEMJ/QMTS..R	For the bearing used in this rod end, see QMT..			XEMJ/WMTC..R	For the bearing used in this rod end, see WMT..		
XEMJ/RL..	Airframe rod ends – External thread inserted wide self-lubricating spherical plain bearing rod end (metric dimensions), 17-4PH H1025 corrosion-resistant-steel rod end	3.4	302	XEMJ/WMT..R	Airframe rod ends – External thread inserted high misalignment metal-to-metal spherical plain bearing rod end (inch dimensions), corrosion-resistant-steel rod end body, corrosion-resistant-steel inner ring and corrosion-resistant-steel outer ring without lubrication groove	3.33	300
XEMJ/RL..	For the bearing used in this rod end, see WEN..			XEMJ/WMT..R	For the bearing used in this rod end, see WMT..		
XEMJ/RL..R..	Airframe rod ends – External thread inserted wide self-lubricating spherical plain bearing rod end (inch dimensions), 17-4PH H1025 corrosion-resistant-steel rod end	3.23	310	XEMJ/WMTS..R	Airframe rod ends – External thread inserted high misalignment metal-to-metal spherical plain bearing rod end (inch dimensions), corrosion-resistant-steel rod end body, corrosion-resistant-steel inner ring and corrosion-resistant-steel outer ring with lubrication by the inner ring	3.33	300
XEMJ/RL..R..	For the bearing used in this rod end, see WAS..			XEMJ/WMTS..R	For the bearing used in this rod end, see WMT..		
XEMJ/RT..	Airframe rod ends – External thread inserted high-misalignment self-lubricating spherical plain bearing rod end (metric dimensions), 17-4PH H1025 corrosion-resistant-steel rod end	3.5	346	XEMJ/WQMLC..R	Airframe rod ends – External thread inserted wide metal-to-metal spherical plain bearing rod end (inch dimensions), corrosion-resistant-steel rod end body, corrosion-resistant-steel inner ring and bronze aluminium outer ring with lubrication by the rod end body	3.32	374
XEMJ/RT..	For the bearing used in this rod end, see XRT..			XEMJ/WQMLC..R	For the bearing used in this rod end, see WQML..		
XEMJ/RT..R..	Airframe rod ends – External thread inserted high-misalignment self-lubricating spherical plain bearing rod end (inch dimensions), 17-4PH H1025 corrosion-resistant-steel rod end	3.24	348	XEMJ/WQML..R	Airframe rod ends – External thread inserted wide metal-to-metal spherical plain bearing rod end (inch dimensions), corrosion-resistant-steel rod end body, corrosion-resistant-steel inner ring and bronze aluminium outer ring without lubrication groove	3.32	374
XEMJ/RT..R..	For the bearing used in this rod end, see XRT..						
XEMJ/WMLC..R	Airframe rod ends – External thread inserted wide metal-to-metal spherical plain bearing rod end (inch dimensions), corrosion-resistant-steel rod end body, corrosion-resistant-steel inner ring and corrosion-resistant-steel outer ring with lubrication by the rod end body	3.32	374				

¹⁾ Starting page of the product table.

Designation	Product	Product table No. Page ¹⁾	Designation	Product	Product table No. Page ¹⁾
XEMJ/WQML..R	For the bearing used in this rod end, see WQML..		XRE..	For the cross-reference designation of this legacy product, see NEN.., NAS..	
XEMJ/WQMLS..R	Airframe rod ends – External thread inserted wide metal-to-metal spherical plain bearing rod end (inch dimensions), corrosion-resistant-steel rod end body, corrosion-resistant-steel inner ring and bronze aluminium outer ring with lubrication by the inner ring	3.32 374	XRE..A..	For the cross-reference designation of this legacy product, see NAS..A..	
XEMJ/WQMLS..R	For the bearing used in this rod end, see WQML..		XREP..	Airframe rod ends – Internal thread rod end with integrated rolling bearing (inch dimensions), bearing in corrosion-resistant-steel and rod end body in corrosion-resistant-steel with right-hand thread	3.17 334
XEMJ/WQMTC..R	Airframe rod ends – External thread inserted high misalignment metal-to-metal spherical plain bearing rod end (inch dimensions), corrosion-resistant-steel rod end body, corrosion-resistant-steel inner ring and bronze aluminium outer ring with lubrication by the rod end body	3.33 300	XREP..F..	Airframe rod ends – Internal thread rod end with integrated rolling bearing (inch dimensions), bearing in corrosion-resistant-steel and rod end body in corrosion-resistant-steel with right-hand thread	3.17 334
XEMJ/WQMTC..R	For the bearing used in this rod end, see WQMT..		XREP..FL..	Airframe rod ends – Internal thread rod end with integrated rolling bearing (inch dimensions), bearing in corrosion-resistant-steel and rod end body in corrosion-resistant-steel with left-hand thread	3.17 334
XEMJ/WQMT..R	Airframe rod ends – External thread inserted high misalignment metal-to-metal spherical plain bearing rod end (inch dimensions), corrosion-resistant-steel rod end body, corrosion-resistant-steel inner ring and bronze aluminium outer ring without lubrication groove	3.33 300	XREP..L..	Airframe rod ends – Internal thread rod end with integrated rolling bearing (inch dimensions), bearing in corrosion-resistant-steel and rod end body in corrosion-resistant-steel with left-hand thread	3.16 332
XEMJ/WQMT..R	For the bearing used in this rod end, see WQMT..		XREP..M..	Airframe rod ends – External thread rod end with integrated rolling bearing (inch dimensions), bearing in corrosion-resistant-steel and rod end body in corrosion-resistant-steel with right-hand thread	3.16 332
XEMJ/WQMTS..R	Airframe rod ends – External thread inserted high misalignment metal-to-metal spherical plain bearing rod end (inch dimensions), corrosion-resistant-steel rod end body, corrosion-resistant-steel inner ring and bronze aluminium outer ring with lubrication by the inner ring	3.33 300	XREP..ML..	Airframe rod ends – External thread rod end with integrated rolling bearing (inch dimensions), bearing in corrosion-resistant-steel and rod end body in corrosion-resistant-steel with left-hand thread	3.16 332
XEMJ/WQMTS..R	For the bearing used in this rod end, see WQMT..		XREP..MR..	Airframe rod ends – External thread rod end with integrated rolling bearing (inch dimensions), bearing in corrosion-resistant-steel and rod end body in corrosion-resistant-steel with right-hand thread	2.23 228
XRA..	For the cross-reference designation of this legacy product, see LEN..		XRL..	For the cross-reference designation of this legacy product, see WEN.., WAS..	
XRA..M..	Airframe rod ends – External thread rod end with integrated rolling bearing (inch dimensions), bearing in corrosion-resistant-steel and rod end body in corrosion-resistant-steel with right-hand thread	3.16 332	XRL..A..	For the cross-reference designation of this legacy product, see WAS..A..	
XRA..ML..	Airframe rod ends – External thread rod end with integrated rolling bearing (inch dimensions), bearing in corrosion-resistant-steel and rod end body in corrosion-resistant-steel with left-hand thread	3.16 332	XRL..FR..	Airframe spherical plain bearings – Self-lubricating pre-staked (metric dimensions), not plated	2.22 226
XRAP..M..	Airframe rod ends – External thread rod end with integrated rolling bearing (inch dimensions), bearing in corrosion-resistant-steel and rod end body in corrosion-resistant-steel with right-hand thread	3.16 332	XRT..	Airframe spherical plain bearings – Self-lubricating high-misalignment (metric dimensions), not plated	2.33 260
XRAP..ML..	Airframe rod ends – External thread rod end with integrated rolling bearing (inch dimensions), bearing in corrosion-resistant-steel and rod end body in corrosion-resistant-steel with left-hand thread	3.16 322	XRT..	Airframe spherical plain bearings – Self-lubricating high-misalignment (inch dimensions), not plated	
			XRT..	For rod ends using this bearing, see EMJ/RT.., SEMJ/RT.., XEMJ/RT.., TEMJ/RT.., EFJ/RT.., SEFJ/RT.., XEFJ/RT.., TEFJ/RT.., EMJ/RT..R.., SEMJ/RT..R.., XEMJ/RT..R.., TEMJ/RT..R.., EFJ/RT..R.., SEFJ/RT..R.., XEFJ/RT..R.., TEFJ/RT..R..	

¹⁾ Starting page of the product table.

Designation	Product	Product table		Designation	Product	Product table	
		No.	Page ¹⁾			No.	Page ¹⁾
XTRCE..	Airframe rolling bearings – Deep groove ball bearing with self-aligning ring single row, EN 3061 (metric dimensions), corrosion-resistant-steel bearing and corrosion-resistant-steel self-aligning ring	1.7	64	ZGLS..	Airframe spherical plain bearings – Metal-to-metal loader slot normal (metric dimensions), bearing steel inner ring and outer ring cadmium plated	2.2	160
XTRCEI..	Airframe rolling bearings – Deep groove ball bearing with self-aligning ring single row, EN 4041 (metric dimensions), corrosion-resistant-steel bearing and corrosion-resistant-steel self-aligning ring	1.8	56	ZGLS..MRTG	Airframe spherical plain bearings – Metal-to-metal loader slot normal reinforced (metric dimensions), bearing steel inner ring and outer ring cadmium plated with molybdenum disulfide	2.3	164
ZAG..	Airframe rolling bearings – Deep groove ball bearing double row (metric dimensions), cadmium plated bearing steel	1.5	60	ZGLS..RTG	Airframe spherical plain bearings – Metal-to-metal loader slot normal reinforced (metric dimensions), bearing steel inner ring and outer ring cadmium plated	2.3	164
ZAGN..	Airframe rolling bearings – Deep groove ball bearing double row, EN 3057 (metric dimensions), cadmium plated bearing steel	1.6	62	ZGLS..TAG	Airframe spherical plain bearings – Metal-to-metal loader slot normal (metric dimensions), bearing steel inner ring and outer ring cadmium plated	2.2	160
ZENAS..	Airframe spherical plain bearings – Self-lubricating narrow, AS 14101, AS 14104 (inch dimensions), PH13.8 inner ring and cadmium plated outer ring	2.26	236	ZGT..	Airframe spherical plain bearings – Metal-to-metal loader slot wide (metric dimensions), bearing steel inner ring and outer ring cadmium plated	2.4	166
ZENAS..A..	Airframe spherical plain bearings – Self-lubricating narrow, AS 81820/1, AS 81820/4 (inch dimensions), PH13.8 inner ring and cadmium plated outer ring	2.27	240	ZGT..	Airframe spherical plain bearings – Metal-to-metal loader slot wide (inch dimensions), bearing steel inner ring and outer ring cadmium plated	2.10	184
ZENE..	Airframe spherical plain bearings – Metal-to-metal swaged narrow, EN 6046 (inch dimensions), cadmium plated	2.12	190	ZHMEN..	Airframe spherical plain bearings – Self-lubricating high-misalignment (metric dimensions), cadmium plated	2.21	224
ZENL..	Airframe spherical plain bearings – Metal-to-metal swaged wide, EN 4266 (inch dimensions), cadmium plated	2.14	198	ZJN..	Airframe rolling bearings – Deep groove ball bearing single row (metric dimensions), cadmium plated bearing steel	1.1	52
ZEWAS..	Airframe spherical plain bearings – Self-lubricating narrow, AS 14102, AS 14103 (inch dimensions), PH13.8 inner ring and cadmium plated outer ring	2.29	248	ZJNA..	Airframe rolling bearings – Deep groove ball bearing single row, EN 3285, EN 3046 (metric dimensions), cadmium plated bearing steel	1.2	54
ZEWAS..	For rod ends using this bearing, see EMJ/WAS..., SEMJ/WAS..., EPHMJ/WAS..., EFJ/WAS..., SEFJ/WAS..., PHFJ/WAS..			ZK..	Airframe rolling bearings – Spherical roller bearing single row, EN 3054 (metric dimensions), cadmium plated bearing steel	1.11	72
ZEWAS..A..	Airframe spherical plain bearings – Self-lubricating narrow, AS 81820/2, AS 81820/3 (inch dimensions), PH13.8 inner ring and cadmium plated outer ring	2.30	252	ZK..D	Airframe rolling bearings – Spherical roller bearing double row (metric dimensions), cadmium plated bearing steel	1.13	76
ZGE..	Airframe spherical plain bearings – Metal-to-metal loader slot (metric dimensions), bearing steel inner ring and outer ring cadmium plated	2.1	156	ZK..F	Airframe rolling bearings – Spherical roller bearing single row, EN 3054 (metric dimensions), cadmium plated bearing steel	1.11	72
ZGL..	Airframe spherical plain bearings – Metal-to-metal loader slot normal (metric dimensions), bearing steel inner ring and outer ring cadmium plated	2.2	160	ZKN..	Airframe rolling bearings – Self-aligning ball bearing double row, EN 3288 (metric dimensions), cadmium plated bearing steel	1.9	68
ZGLD..	Airframe spherical plain bearings – Metal-to-metal loader slot normal (metric dimensions), bearing steel inner ring and outer ring cadmium plated	2.2	160	ZKN..	Airframe rolling bearings – Self-aligning ball bearing double row (inch dimensions), cadmium plated bearing steel	1.25	112
				ZKN..	Airframe rolling bearings – Spherical roller bearing single row, EN 3054 (metric dimensions), cadmium plated bearing steel	1.11	72
				ZKNA..F	Airframe rolling bearings – Spherical roller bearing single row, EN 3291 (metric dimensions), cadmium plated bearing steel	1.12	74

¹⁾ Starting page of the product table.

Designation	Product	Product table		Designation	Product	Product table	
		No.	Page ¹⁾			No.	Page ¹⁾
ZKN..F	Airframe rolling bearings – Spherical roller bearing single row, EN 3054 (metric dimensions), cadmium plated bearing steel	1.11	72	ZQGLS..TAG	Airframe spherical plain bearings – Metal-to-metal loader slot normal (metric dimensions), bronze beryllium inner ring and corrosion-resistant-steel outer ring cadmium plated	2.2	160
ZKNRCE..	Airframe rolling bearings – Self-aligning ball bearing double row (metric dimensions), cadmium plated bearing steel	1.10	70	ZQGT..	Airframe spherical plain bearings – Metal-to-metal loader slot wide (metric dimensions), bronze beryllium inner ring and corrosion-resistant-steel outer ring cadmium plated	2.4	166
ZLEN..	Airframe spherical plain bearings – Self-lubricating light (metric dimensions), cadmium plated	2.18	214	ZQGT..	Airframe spherical plain bearings – Metal-to-metal loader slot wide (inch dimensions), bronze beryllium inner ring and corrosion-resistant-steel outer ring cadmium plated	2.10	184
ZNAS..	Airframe spherical plain bearings – Self-lubricating narrow, AS 14101, AS 14104 (inch dimensions), 440C inner ring and cadmium plated outer ring	2.26	236	ZQMA..	Airframe spherical plain bearings – Metal-to-metal swaged light (metric dimensions), bronze beryllium inner ring and corrosion-resistant-steel outer ring cadmium plated	2.5	168
ZNAS..A..	Airframe spherical plain bearings – Self-lubricating narrow, AS 81820/1, AS 81820/4 (inch dimensions), 440C inner ring and cadmium plated outer ring	2.27	240	ZQME..	Airframe spherical plain bearings – Metal-to-metal swaged narrow (metric dimensions), bronze beryllium inner ring and corrosion-resistant-steel outer ring cadmium plated	2.6	172
ZNEN..	Airframe spherical plain bearings – Self-lubricating narrow (metric dimensions), cadmium plated	2.19	216	ZQME..	Airframe spherical plain bearings – Metal-to-metal swaged narrow (inch dimensions), bronze beryllium inner ring and corrosion-resistant-steel outer ring cadmium plated	2.11	186
ZQ2PL..	Airframe spherical plain bearings – Metal-to-metal swaged split (metric dimensions), bronze beryllium inner ring and corrosion-resistant-steel outer ring cadmium plated	2.9	182	ZQML..	Airframe spherical plain bearings – Metal-to-metal swaged wide (metric dimensions), bronze beryllium inner ring and corrosion-resistant-steel outer ring cadmium plated	2.7	176
ZQ2PL..	Airframe spherical plain bearings – Metal-to-metal swaged split (inch dimensions), bronze beryllium inner ring and corrosion-resistant-steel outer ring cadmium plated	2.17	210	ZQML..	Airframe spherical plain bearings – Metal-to-metal swaged wide (inch dimensions), bronze beryllium inner ring and corrosion-resistant-steel outer ring cadmium plated	2.13	194
ZQGE..	Airframe spherical plain bearings – Metal-to-metal loader slot (metric dimensions), bronze beryllium inner ring and corrosion-resistant-steel outer ring cadmium plated	2.1	156	ZQMT..	Airframe spherical plain bearings – Metal-to-metal swaged high misalignment (metric dimensions), bronze beryllium inner ring and corrosion-resistant-steel outer ring cadmium plated	2.8	180
ZQGL..	Airframe spherical plain bearings – Metal-to-metal loader slot normal (metric dimensions), bronze beryllium inner ring and corrosion-resistant-steel outer ring cadmium plated	2.2	160	ZQMT..	Airframe spherical plain bearings – Metal-to-metal swaged high misalignment (inch dimensions), bronze beryllium inner ring and corrosion-resistant-steel outer ring cadmium plated	2.15	202
ZQGLD..	Airframe spherical plain bearings – Metal-to-metal loader slot normal (metric dimensions), bronze beryllium inner ring and corrosion-resistant-steel outer ring cadmium plated	2.2	160	ZQXMB..	Airframe spherical plain bearings – Metal-to-metal swaged (inch dimensions), cadmium plated	2.16	206
ZQGLS..	Airframe spherical plain bearings – Metal-to-metal loader slot normal (metric dimensions), bronze beryllium inner ring and corrosion-resistant-steel outer ring cadmium plated	2.2	160	ZRL..SP....	For the cross-reference designation of this legacy product, see ZHMEN..		
ZQGLS..MRTG	Airframe spherical plain bearings – Metal-to-metal loader slot normal reinforced (metric dimensions), bronze beryllium inner ring and corrosion-resistant-steel outer ring cadmium plated with molybdenum disulfide	2.3	164	ZT..	Airframe rolling bearings – Deep groove ball bearing single row (metric dimensions), cadmium plated bearing steel	1.3	56
ZQGLS..RTG	Airframe spherical plain bearings – Metal-to-metal loader slot normal reinforced (metric dimensions), bronze beryllium inner ring and corrosion-resistant-steel outer ring cadmium plated	2.3	164	ZTA..	Airframe rolling bearings – Deep groove ball bearing single row, EN 3282 (metric dimensions), cadmium plated bearing steel	1.4	58

¹⁾ Starting page of the product table.

Designation	Product	Product table		Designation	Product	Product table	
		No.	Page ¹⁾			No.	Page ¹⁾
ZTRCE..	Airframe rolling bearings – Deep groove ball bearing with self-aligning ring single row EN 3060 (metric dimensions), cadmium plated bearing steel bearing and cadmium plated steel self-aligning ring	1.7	64	ZWDW..K2	Airframe rolling bearings – Deep groove ball bearing double row (inch dimensions), cadmium plated corrosion-resistant-steel, standard tolerance	1.21	100
ZW2PL..	Airframe spherical plain bearings – Metal-to-metal swaged split (metric dimensions), corrosion-resistant-steel inner ring and outer ring cadmium plated	2.9	182	ZWEN..	Airframe spherical plain bearings – Self-lubricating wide (metric dimensions), cadmium plated	2.20	220
ZW2PL..	Airframe spherical plain bearings – Metal-to-metal swaged split (inch dimensions), corrosion-resistant-steel inner ring and outer ring cadmium plated	2.17	210	ZWGL..	Airframe spherical plain bearings – Metal-to-metal loader slot normal (metric dimensions), corrosion-resistant-steel inner ring and outer ring cadmium plated	2.2	160
ZWAG..	Airframe rolling bearings – Deep groove ball bearing double row (metric dimensions), cadmium plated corrosion-resistant-steel	1.5	60	ZWGLD..	Airframe spherical plain bearings – Metal-to-metal loader slot normal (metric dimensions), corrosion-resistant-steel inner ring and outer ring cadmium plated	2.2	160
ZWAGN..	Airframe rolling bearings – Deep groove ball bearing double row (metric dimensions), cadmium plated corrosion-resistant-steel	1.6	62	ZWGLS..	Airframe spherical plain bearings – Metal-to-metal loader slot normal (metric dimensions), corrosion-resistant-steel inner ring and outer ring cadmium plated	2.2	160
ZWAS..	Airframe spherical plain bearings – Self-lubricating narrow, AS 14102, AS 14103 (inch dimensions), 440C inner ring and cadmium plated outer ring	2.29	248	ZWGLS..MRTG	Airframe spherical plain bearings – Metal-to-metal loader slot normal reinforced (metric dimensions), corrosion-resistant-steel inner ring and outer ring cadmium plated with molybdenum disulfide	2.3	164
ZWAS..A..	Airframe spherical plain bearings – Self-lubricating narrow, AS 81820/2, AS 81820/3 (inch dimensions), 440C inner ring and cadmium plated outer ring	2.30	252	ZWGLS..RTG	Airframe spherical plain bearings – Metal-to-metal loader slot normal reinforced (metric dimensions), corrosion-resistant-steel inner ring and outer ring cadmium plated	2.3	164
ZWATA..	Airframe rolling bearings – Deep groove ball bearing single row (metric dimensions), cadmium plated corrosion-resistant-steel	1.4	58	ZWGLS..TAG	Airframe spherical plain bearings – Metal-to-metal loader slot normal (metric dimensions), corrosion-resistant-steel inner ring and outer ring cadmium plated	2.2	160
ZWB5..	Airframe rolling bearings – Deep groove ball bearing single row (inch dimensions), cadmium plated corrosion-resistant-steel, standard tolerance	1.18	92	ZWGT..	Airframe spherical plain bearings – Metal-to-metal loader slot wide (metric dimensions), corrosion-resistant-steel inner ring and outer ring cadmium plated	2.4	166
ZWB55..	Airframe rolling bearings – Deep groove ball bearing double row (inch dimensions), cadmium plated corrosion-resistant-steel	1.19	96	ZWGT..	Airframe spherical plain bearings – Metal-to-metal loader slot wide (inch dimensions), corrosion-resistant-steel inner ring and outer ring cadmium plated	2.10	184
ZWDPP..	Airframe rolling bearings – Deep groove ball bearing double row (inch dimensions), cadmium plated corrosion-resistant-steel, standard tolerance	1.20	98	ZWJN..	Airframe rolling bearings – Deep groove ball bearing single row (metric dimensions), cadmium plated corrosion-resistant-steel	1.1	52
ZWDSP..	Airframe rolling bearings – Self-aligning ball bearing double row (inch dimensions), cadmium plated corrosion-resistant-steel, standard tolerance	1.26	114	ZWJNA..	Airframe rolling bearings – Deep groove ball bearing single row (metric dimensions), cadmium plated corrosion-resistant-steel	1.2	54
ZWDSRP..	Airframe rolling bearings – Spherical roller bearing single row (inch dimensions), cadmium plated corrosion-resistant-steel	1.27	116	ZWK..	Airframe rolling bearings – Spherical roller bearing single row (metric dimensions), cadmium plated corrosion-resistant-steel	1.11	72
ZWDW..	Airframe rolling bearings – Deep groove ball bearing double row (inch dimensions), cadmium plated corrosion-resistant-steel, standard tolerance	1.21	100	ZWK..D	Airframe rolling bearings – Spherical roller bearing double row (metric dimensions), cadmium plated corrosion-resistant-steel	1.13	76
ZWDW..K	Airframe rolling bearings – Deep groove ball bearing double row (inch dimensions), cadmium plated corrosion-resistant-steel, standard tolerance	1.21	100	ZWKN..	Airframe rolling bearings – Self-aligning ball bearing double row (metric dimensions), cadmium plated corrosion-resistant-steel	1.9	68

¹⁾ Starting page of the product table.

Designation	Product	Product table No. Page ¹⁾	Designation	Product	Product table No. Page ¹⁾
ZWKN..	Airframe rolling bearings – Self-aligning ball bearing double row (inch dimensions), zinc-nickel plated corrosion-resistant-steel	1.25 112	ZWKSP..	Airframe rolling bearings – Self-aligning ball bearing single row (inch dimensions), cadmium plated corrosion-resistant-steel, standard tolerance	1.23 106
ZWKN..	Airframe rolling bearings – Spherical roller bearing single row (metric dimensions), cadmium plated corrosion-resistant-steel	1.11 72	ZWKSP..A	Airframe rolling bearings – Self-aligning ball bearing single row (inch dimensions), cadmium plated corrosion-resistant-steel, standard tolerance	1.23 106
ZWKNA..F	Airframe rolling bearings – Spherical roller bearing single row (metric dimensions), cadmium plated corrosion-resistant-steel	1.12 74	ZWKSP..APSP..	Airframe rolling bearings – Self-aligning ball bearing single row (inch dimensions), cadmium plated corrosion-resistant-steel, shielded	1.24 110
ZWKN..F	Airframe rolling bearings – Spherical roller bearing single row (metric dimensions), cadmium plated corrosion-resistant-steel	1.11 72	ZWKSP..ASP..	Airframe rolling bearings – Self-aligning ball bearing single row (inch dimensions), cadmium plated corrosion-resistant-steel, sealed	1.24 110
ZWKNRCE..	Airframe rolling bearings – Self-aligning ball bearing double row (metric dimensions), cadmium plated corrosion-resistant-steel	1.10 70	ZWKSP..L	Airframe rolling bearings – Self-aligning ball bearing single row (inch dimensions), cadmium plated corrosion-resistant-steel, standard tolerance	1.23 106
ZWKP..	Airframe rolling bearings – Deep groove ball bearing single row (inch dimensions), cadmium plated corrosion-resistant-steel, standard tolerance	1.14 78	ZWKSP..PSP..	Airframe rolling bearings – Self-aligning ball bearing single row (inch dimensions), cadmium plated corrosion-resistant-steel, shielded	1.24 110
ZWKP..A	Airframe rolling bearings – Deep groove ball bearing single row (inch dimensions), cadmium plated corrosion-resistant-steel, standard tolerance	1.15 80	ZWKSP..SP..	Airframe rolling bearings – Self-aligning ball bearing single row (inch dimensions), cadmium plated corrosion-resistant-steel, sealed	1.24 110
ZWKP..APSP..	Airframe rolling bearings – Deep groove ball bearing single row (inch dimensions), cadmium plated corrosion-resistant-steel, shielded	1.17 90	ZWMA..	Airframe spherical plain bearings – Metal-to-metal swaged light (metric dimensions), corrosion-resistant-steel inner ring and outer ring cadmium plated	2.5 168
ZWKP..ASP..	Airframe rolling bearings – Deep groove ball bearing single row (inch dimensions), cadmium plated corrosion-resistant-steel, sealed	1.17 90	ZWMB5..	Airframe rolling bearings – Deep groove ball bearing single row (inch dimensions), cadmium plated corrosion-resistant-steel, reduced clearance and precision	1.18 92
ZWKP..B	Airframe rolling bearings – Deep groove ball bearing single row (inch dimensions), cadmium plated corrosion-resistant-steel, standard tolerance	1.16 84	ZWMDPP..	Airframe rolling bearings – Deep groove ball bearing double row (inch dimensions), cadmium plated corrosion-resistant-steel, reduced tolerance and SKF super precision	1.20 98
ZWKP..BS	Airframe rolling bearings – Deep groove ball bearing with self-aligning ring single row (inch dimensions), cadmium plated corrosion-resistant-steel, standard tolerance	1.22 102	ZWMDSP..	Airframe rolling bearings – Self-aligning ball bearing double row (inch dimensions), cadmium plated corrosion-resistant-steel, reduced tolerance and SKF super precision	1.26 114
ZWKP..L	Airframe rolling bearings – Deep groove ball bearing single row (inch dimensions), cadmium plated corrosion-resistant-steel, standard tolerance	1.14 78	ZWMDW..	Airframe rolling bearings – Deep groove ball bearing double row (inch dimensions), cadmium plated corrosion-resistant-steel, reduced tolerance and SKF super precision	1.21 100
ZWKP..LPSP..	Airframe rolling bearings – Deep groove ball bearing single row (inch dimensions), cadmium plated corrosion-resistant-steel, shielded	1.17 90	ZWMDW..K	Airframe rolling bearings – Deep groove ball bearing double row (inch dimensions), cadmium plated corrosion-resistant-steel, reduced tolerance and SKF super precision	1.21 100
ZWKP..LSP..	Airframe rolling bearings – Deep groove ball bearing single row (inch dimensions), cadmium plated corrosion-resistant-steel, sealed	1.17 90	ZWMDW..K2	Airframe rolling bearings – Deep groove ball bearing double row (inch dimensions), cadmium plated corrosion-resistant-steel, reduced tolerance and SKF super precision	1.21 100
ZWKP..PSP..	Airframe rolling bearings – Deep groove ball bearing single row (inch dimensions), cadmium plated corrosion-resistant-steel, shielded	1.17 90			
ZWKP..SP..	Airframe rolling bearings – Deep groove ball bearing single row (inch dimensions), cadmium plated corrosion-resistant-steel, sealed	1.17 90			

¹⁾ Starting page of the product table.

Designation	Product	Product table		Designation	Product	Product table	
		No.	Page ¹⁾			No.	Page ¹⁾
ZWME..	Airframe spherical plain bearings – Metal-to-metal swaged narrow (metric dimensions), corrosion-resistant-steel inner ring and outer ring cadmium plated	2.6	172	ZWMT..	Airframe spherical plain bearings – Metal-to-metal swaged high misalignment (inch dimensions), corrosion-resistant-steel inner ring and outer ring cadmium plated	2.15	202
ZWME..	Airframe spherical plain bearings – Metal-to-metal swaged narrow, AS 21154, AS 21155 (inch dimensions), corrosion-resistant-steel inner ring and outer ring cadmium plated	2.11	186	ZWQ2PL..	Airframe spherical plain bearings – Metal-to-metal swaged split (metric dimensions), corrosion-resistant-steel inner ring and bronze aluminium outer ring cadmium plated	2.9	182
ZWMKP..	Airframe rolling bearings – Deep groove ball bearing single row (inch dimensions), cadmium plated corrosion-resistant-steel, reduced tolerance and SKF super precision	1.14	78	ZWQ2PL..	Airframe spherical plain bearings – Metal-to-metal swaged split (inch dimensions), corrosion-resistant-steel inner ring and bronze aluminium outer ring cadmium plated	2.17	210
ZWMKP..A	Airframe rolling bearings – Deep groove ball bearing single row (inch dimensions), cadmium plated corrosion-resistant-steel, reduced tolerance and SKF super precision	1.15	80	ZWQMA..	Airframe spherical plain bearings – Metal-to-metal swaged light (metric dimensions), corrosion-resistant-steel inner ring and bronze aluminium outer ring cadmium plated	2.5	168
ZWMKP..B	Airframe rolling bearings – Deep groove ball bearing single row (inch dimensions), cadmium plated corrosion-resistant-steel, reduced tolerance and SKF super precision	1.16	84	ZWQME..	Airframe spherical plain bearings – Metal-to-metal swaged narrow (metric dimensions), corrosion-resistant-steel inner ring and bronze aluminium outer ring cadmium plated	2.6	172
ZWMKP..BS	Airframe rolling bearings – Deep groove ball bearing with self-aligning ring single row (inch dimensions), cadmium plated corrosion-resistant-steel, reduced tolerance and SKF super precision	1.22	102	ZWQME..	Airframe spherical plain bearings – Metal-to-metal swaged narrow, AS 21154, AS 21155 (inch dimensions), corrosion-resistant-steel inner ring and bronze aluminium outer ring cadmium plated	2.11	186
ZWMKP..L	Airframe rolling bearings – Deep groove ball bearing single row (inch dimensions), cadmium plated corrosion-resistant-steel, reduced tolerance and SKF super precision	1.14	78	ZWQML..	Airframe spherical plain bearings – Metal-to-metal swaged wide (metric dimensions), corrosion-resistant-steel inner ring and bronze aluminium outer ring cadmium plated	2.7	176
ZWMKSP..	Airframe rolling bearings – Self-aligning ball bearing single row (inch dimensions), cadmium plated corrosion-resistant-steel, reduced tolerance and SKF super precision	1.23	106	ZWQML..	Airframe spherical plain bearings – Metal-to-metal swaged wide (inch dimensions), corrosion-resistant-steel inner ring and bronze aluminium outer ring cadmium plated	2.13	194
ZWMKSP..A	Airframe rolling bearings – Self-aligning ball bearing single row (inch dimensions), cadmium plated corrosion-resistant-steel, reduced tolerance and SKF super precision	1.23	106	ZWQMT..	Airframe spherical plain bearings – Metal-to-metal swaged high misalignment (metric dimensions), corrosion-resistant-steel inner ring and bronze aluminium outer ring cadmium plated	2.8	180
ZWMKSP..L	Airframe rolling bearings – Self-aligning ball bearing single row (inch dimensions), cadmium plated corrosion-resistant-steel, reduced tolerance and SKF super precision	1.23	106	ZWQMT..	Airframe spherical plain bearings – Metal-to-metal swaged high misalignment (inch dimensions), corrosion-resistant-steel inner ring and bronze aluminium outer ring cadmium plated	2.15	202
ZWML..	Airframe spherical plain bearings – Metal-to-metal swaged wide (metric dimensions), corrosion-resistant-steel inner ring and outer ring cadmium plated	2.7	176	ZWT..	Airframe rolling bearings – Deep groove ball bearing single row (metric dimensions), cadmium plated corrosion-resistant-steel	1.3	56
ZWML..	Airframe spherical plain bearings – Metal-to-metal swaged wide (inch dimensions), corrosion-resistant-steel inner ring and outer ring cadmium plated	2.13	194	ZXC..M	Airframe rod ends – External thread rod end with integrated rolling bearing (metric dimensions), shielded bearing in corrosion-resistant-steel and rod end body in cadmium plated corrosion-resistant-steel	3.2	298
ZWMT..	Airframe spherical plain bearings – Metal-to-metal swaged high misalignment (metric dimensions), corrosion-resistant-steel inner ring and outer ring cadmium plated	2.8	180				

¹⁾ Starting page of the product table.

Designation	Product	Product table		Designation	Product	Product table	
		No.	Page ¹⁾			No.	Page ¹⁾
ZXC..ME	Airframe rod ends – External thread rod end with integrated rolling bearing (metric dimensions), sealed bearing in corrosion-resistant-steel and rod end body in cadmium plated corrosion-resistant-steel	3.2	298	ZXCN..MSP..	Airframe rod ends – External thread rod end with integrated rolling bearing (inch dimensions), shielded bearing in corrosion-resistant-steel and rod end body in cadmium plated corrosion-resistant-steel with UNF profile thread	3.14	322
ZXC..MJ..	Airframe rod ends – External thread rod end with integrated rolling bearing (metric dimensions), bearing in corrosion-resistant-steel and rod end body in cadmium plated corrosion-resistant-steel	3.1	296	ZXCN..MSP1	Airframe rod ends – External thread rod end with integrated rolling bearing (metric dimensions), shielded bearing in corrosion-resistant-steel and rod end body in cadmium plated corrosion-resistant-steel	3.2	298
ZXCN...--	Airframe rod ends – External thread rod end with integrated rolling bearing (inch dimensions), shielded bearing in corrosion-resistant-steel and rod end body in cadmium plated corrosion-resistant-steel	3.15	326	ZXRA..	For the cross-reference designation of this legacy product, see ZLEN..		
ZXCN..E..	Airframe rod ends – External thread rod end with integrated rolling bearing (inch dimensions), sealed bearing in corrosion-resistant-steel and rod end body in cadmium plated corrosion-resistant-steel	3.15	326	ZXRE..	For the cross-reference designation of this legacy product, see ZNEN.., ZNAS..		
ZXCN..JESP..	Airframe rod ends – External thread rod end with integrated rolling bearing (inch dimensions), sealed bearing in corrosion-resistant-steel and rod end body in cadmium plated corrosion-resistant-steel with UNJF profile thread	3.14	322	ZXRE..A..	For the cross-reference designation of this legacy product, see ZNAS..A..		
ZXCN..JSP..	Airframe rod ends – External thread rod end with integrated rolling bearing (inch dimensions), shielded bearing in corrosion-resistant-steel and rod end body in cadmium plated corrosion-resistant-steel with UNJF profile thread	3.14	322	ZXRL..	For the cross-reference designation of this legacy product, see ZWEN.., ZWAS..		
ZXCN..M	Airframe rod ends – External thread rod end with integrated rolling bearing (metric dimensions), shielded bearing in corrosion-resistant-steel and rod end body in cadmium plated corrosion-resistant-steel	3.2	298	ZXRL..A..	For the cross-reference designation of this legacy product, see ZWAS..A..		
ZXCN..ME	Airframe rod ends – External thread rod end with integrated rolling bearing (metric dimensions), sealed bearing in corrosion-resistant-steel and rod end body in cadmium plated corrosion-resistant-steel	3.2	298	ZXRL..FR..	Airframe spherical plain bearings – Self-lubricating pre-staked (metric dimensions), cadmium plated	2.23	228
ZXCN..MESP..	Airframe rod ends – External thread rod end with integrated rolling bearing (inch dimensions), sealed bearing in corrosion-resistant-steel and rod end body in cadmium plated corrosion-resistant-steel with UNF profile thread	3.14	322	ZXRT..	Airframe spherical plain bearings – Self-lubricating high-misalignment (metric dimensions), cadmium plated	2.22	226
ZXCN..MESP1	Airframe rod ends – External thread rod end with integrated rolling bearing (metric dimensions), sealed bearing in corrosion-resistant-steel and rod end body in cadmium plated corrosion-resistant-steel	3.2	298	ZXRT..	Airframe spherical plain bearings – Self-lubricating high-misalignment (inch dimensions), cadmium plated	2.33	260
ZXCN..MJ..	Airframe rod ends – External thread rod end with integrated rolling bearing (metric dimensions), bearing in corrosion-resistant-steel and rod end body in cadmium plated corrosion-resistant-steel	3.1	296				

¹⁾ Starting page of the product table.

